

BAYLINER®

305

Owner's Manual *Supplement*

Engine Serial Numbers

Port: _____

Starboard: _____

Hull Identification Number: _____

Hull Identification Number

- The Hull Identification Number (HIN) is located on the starboard side of the transom.
- Record the HIN (and the engine serial numbers) in the space provided above.
- Include the HIN with any correspondence or orders.

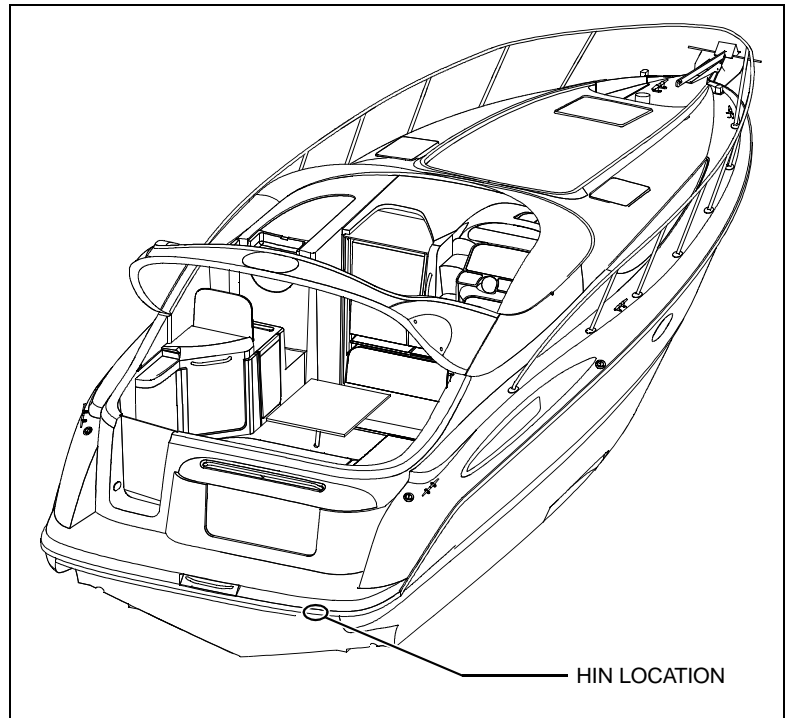

© 2005 Bayliner Technical Publications. All rights reserved.

No part of this publication may be reproduced, stored in any retrieval system, or transmitted in any form by any means, electronic, mechanical, photocopying, recording or otherwise, without prior written permission of Bayliner.

Printed in the United States of America.

General Notes

The material in this document is for information only and is subject to change without notice. While reasonable efforts have been made in the preparation of this document to assure its accuracy, Bayliner assumes no liability resulting from errors or omissions in this document, or from the use of information contained herein. Due to our commitment to product improvement, Bayliner reserves the right to make changes in the product design, specifications, and equipment at any time without notice or obligation. Illustrations and/or photos may show optional equipment.

All Bayliner products meet or exceed USCG (United States Coast Guard) and/or NMMA (National Marine Manufacturer's Association) construction standards. Manufactured with 1,1,1 Trichloroethane, a substance which harms public health and environment during the manufacturing process by destroying ozone in the upper atmosphere.

Proprietary Rights

This document discloses subject matter in which Bayliner has proprietary rights. The information and design disclosed herein were originated by and are the property of Bayliner. Neither receipt nor possession thereof confers or transfers any right to reproduce, copy, alter or disclose the document or any part thereof, any information contained therein, or to construct boats or any item from it, except by written permission from or written agreement with Bayliner. This document is to be returned upon request to Bayliner.

CONTENTS

1 Chapter 1: Welcome Aboard!

- 1 Dimensions & Tank Capacities
- 1 Layout View
- 1 Dealer Service
- 2 Warranty Information
- 2 Boating Experience
- 2 Engine & Accessory Guidelines
 - 3 *Engine & Accessory Literature*
 - 3 *Propellers*
- 3 Qualified Maintenance
- 4 Safety Standards
- 5 Special Care For Moored Boats
 - 5 *Sacrificial Anode (Zinc)*
- 6 Boat Lifting
- 7 Carbon Monoxide (CO)
 - 7 *CO Facts*
 - 7 *Factors that Increase the Effects of CO Poisoning*
 - 8 *Where and How CO Can Accumulate*
 - 8 *How to Protect Yourself and Others From CO*
 - 9 *CO Checklists*
 - 9 *CO Monitor*
 - 10 *More Information*

11 Chapter 2: Locations

- 11 Exterior Views
 - 11 *Hull Views*
 - 12 *Forward Deck View*
 - 12 *Aft Deck View*
 - 13 *Helm Station*
- 14 Component Locations

26 Chapter 3: Propulsion & Related Systems

- 26 Engines
- 26 Bilge Blower System
- 27 Fuel System
 - 28
 - 28 *Fuel Fill & Vent*
 - 28 *Gas Engine Fuel Filters*
 - 29 *Fuel Filter/Water Separators (Diesel Engines Only)*
 - 29 *Anti-siphon Valves (Gas Engines Only)*
- 30 Fire Suppression System (If Equipped)
- 31 Quick Oil Drain System
 - 31 *Setting Up the Quick Oil Drain System*
 - 33 *Using the Quick Oil Drain System*

34 Chapter 4: Controls & Gauges

- 34 Steering
- 34 Shift/Throttle Controls
- 34 Power Trim & Tilt
- 35 Trim Tabs
- 36 Gauges
 - 36 *Cleaning Gauges*
 - 36 *Gauge Fogging*
 - 36 *Radio Transmission Interference*
 - 36 *Fuel Gauge*
 - 36 *Twin Engine Readings*

37 Chapter 5: Navigation & Communication Equipment

- 37 Compass
- 37 Depth Finder
- 37 VHF Radio (If Equipped)

38 Chapter 6: Plumbing

- 38 Bilge Pumps
 - 39 *Bilge Pump Testing*
 - 40 *Autofloat Switches*
- 41 Seawater Systems
 - 41 *Seacocks*
 - 41 *Seawater Strainers*
- 42 Freshwater System
 - 42 *Transom Shower (If Equipped)*
 - 43 *Freshwater System Winterization*
 - 44 *Water Heater*
 - 44 *Winterizing the Water Heater*
- 45 Drain Systems
 - 45 *Deck Drains*
 - 45 *Gray Water Drains*
 - 45 *Shower Drain Pump System*
- 46 Marine Head with Holding Tank
 - 46 *Using the Marine Head*
 - 47 *Winterizing the Marine Head*
 - 47 *Macerator (If Equipped)*

48 Chapter 7: Deck Equipment

- 48 Cleats & Tow Eyes
- 48 Windlass (If Equipped)
- 49 Canvas
 - 49 *Bimini Top*
 - 49 *Camper Enclosure (If Equipped)*
 - 50 *Canvas Care*
 - 51 *Clear Vinyl Care*

52 Chapter 8: Appliances & Entertainment Systems

- 52 Alcohol/Electric Stove
- 53 Refrigerator
- 53 Audio Equipment

54 Chapter 9: Convertible Seats, Beds, & Tables

- 54 Dinette to Mid Berth Conversion
- 55 Cockpit Table to Sunlounge Conversion

56 Chapter 10: Lights

- 56 Care & Maintenance
- 56 Interior & Exterior Lights
- 56 Navigation Lights
- 56 Spotlight (If Equipped)

57 Chapter 11: Heating & Air Conditioning

- 57 Air Conditioning System (If Equipped)

58 Chapter 12: Electrical System

- 59 12-Volt DC System
 - 59 *Batteries*
 - 59 *Battery Switches*
 - 60 *Battery Switch Positions*
 - 60 *Fuses & Circuit Breakers*
 - 60 *12-Volt Accessory Outlet(s)*
 - 61 *Alternators*
 - 61 *Battery Charger (If Equipped)*
- 62 110-Volt AC System
 - 63 *Shore Power*
 - 64 *Connecting to Shore Power*
 - 64 *Parallel Switch (If Equipped with Dual Shore Power)*
 - 65 *Generator (If Equipped)*
- 66 Electrical Routings
 - 66 *110-Volt AC Hull Harnesses*
 - 67 *12-Volt DC Hull Harnesses*
 - 68 *12-Volt DC Deck Harnesses*
 - 69 *Radar Wing Harness*
 - 70 *Gas Engines Battery Cable System*
 - 71 *Diesel Engines Battery Cable System*
- 72 Wiring Diagrams
 - 72 *Engine Electrical Systems*
 - 73 *12-Volt DC Electrical System*
 - 74 *110-Volt AC Electrical System*

75 Important Records

76 Float Plan

Hazard Boxes & Symbols

The hazard boxes and symbols shown below are used throughout this supplement to call attention to potentially dangerous situations which could lead to either personal injury or product damage. Read *all* warnings carefully and follow *all* safety instructions.

 **DANGER!**
This box alerts you to immediate hazards which *WILL* cause severe personal injury or death if the warning is ignored.

 **WARNING!**
This box alerts you to hazards or unsafe practices which *COULD* result in severe personal injury or death if the warning is ignored.

 **CAUTION**
This box alerts you to hazards or unsafe practices which *COULD* result in minor personal injury or cause product or property damage if the warning is ignored.

NOTICE
This box calls attention to installation, operation or maintenance information, which is important to proper operation but is not hazard related.

 FIRE HAZARD!	 EXPLOSION HAZARD!	 NO OPEN FLAME!	 ELECTRICAL HAZARD!	 HOT HAZARD!
---	--	---	--	--

 FALLING HAZARD!	 ROTATING PROPELLER HAZARD!	 RUN BILGE BLOWERS FOR 4 MINUTES!
--	---	--

DANGER
CARBON MONOXIDE
CO POISONING HAZARD!

Chapter 1: Welcome Aboard!

- This *Owner's Manual Supplement* provides information about your boat that is **not** covered in the *Cruiser & Yacht Owner's Manual*.
- **Before** using your boat, study this *Owner's Manual Supplement*, the *Cruiser & Yacht Owner's Manual*, and **all** engine and accessory literature carefully.
- Keep this *Owner's Manual Supplement* and the *Cruiser & Yacht Owner's Manual* on your boat in a secure, yet readily available place.

Dimensions & Tank Capacities

Overall Length	Length Rigged	Bridge Clearance	Beam	Draft (Hull)	Draft (Maximum)	Fuel Capacity	Freshwater Capacity	Waste Holding Tank Capacity
31' 6"	32' 2"	7' 10"	11'	1' 9"	2' 9"	157 Gallons	35 Gallons	30 Gallons

Layout View

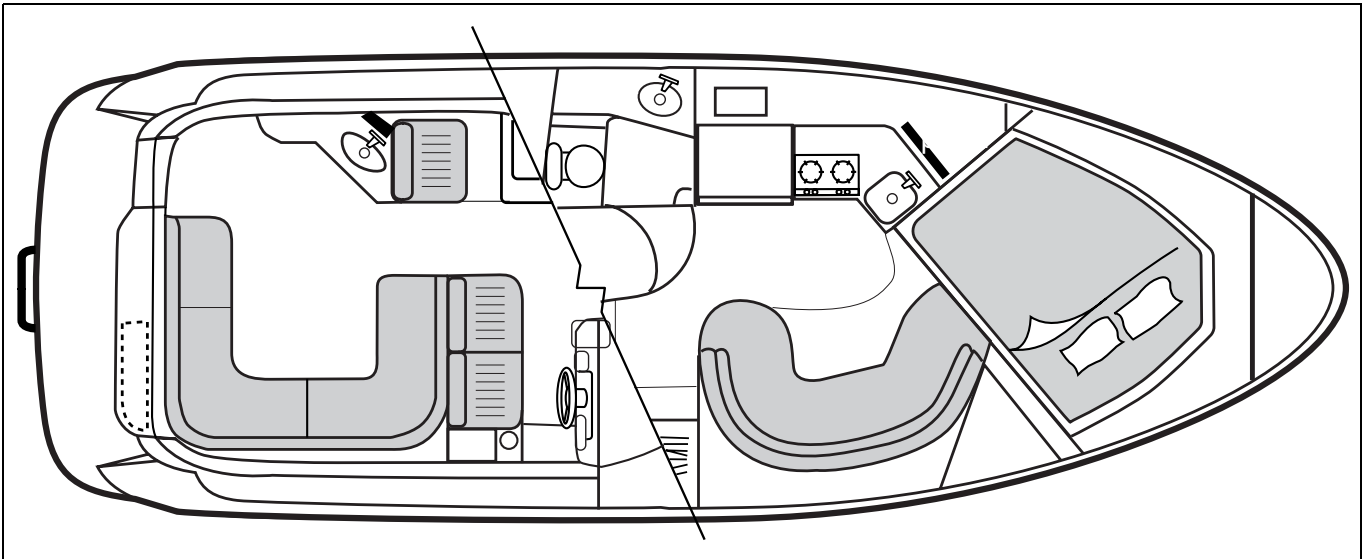

Dealer Service

- Your dealer is your key to service.
- Ask your dealer to explain **all** systems **before** taking delivery of your boat.
- Contact your dealer if you have any problems with your new boat.
- If your dealer cannot help, call our customer service hotline: 360-435-8957 or send us a FAX: 360-403-4235.
- Buy replacement parts from any authorized Bayliner dealer.

Warranty Information

- Bayliner offers a Limited Warranty on each new Bayliner purchased through an authorized Bayliner dealer.
- A copy of the Limited Warranty was included in your owner's packet.
- If you did not receive a copy of the Limited Warranty, please contact your Bayliner dealer or call 360-435-8957 for a copy.

Boating Experience

 WARNING!
CONTROL HAZARD!
A qualified operator <i>must</i> be in control of the boat at <i>all</i> times. Do <i>NOT</i> operate your boat while under the influence of alcohol or drugs.

If this is your first boat or if you are changing to a type of boat you are *not* familiar with, for your own comfort and safety, obtain handling and operating experience *before* assuming command of this boat.

Take one of the boating safety classes offered by the U.S. Power Squadrons or the U.S. Coast Guard Auxiliary. For more course information, including dates and locations of upcoming classes, contact the organizations directly:

- U.S. Power Squadrons: 1-888-FOR-USPS (1-888-367-8777) or on the Internet at: <http://www.usps.org>
- In Canada, for the CPS courses call 1-888-CPS-BOAT.
- U.S. Coast Guard Auxiliary: 1-800-368-5647 or on the Internet at: <http://www.cgaux.org>

Outside the United States, your selling dealer, national sailing federation or local boat club can advise you of local sea schools or competent instructors.

Engine & Accessory Guidelines

NOTICE
When storing your boat please refer to your engine's operation and maintenance manuals.

- Your boat's engines and accessories were selected to provide optimum performance and service.
- Installing different engines or other accessories may cause unwanted handling characteristics.
- Should you choose to install different engines or accessories that will affect the boat's running trim, have an experienced marine technician perform a safety inspection and handling test *before* operating your boat again.

Certain modifications to your boat *will* result in cancellation of your warranty protection.

- *Always* check with your dealer *before* making any modifications to your boat.

Engine & Accessory Literature

- The engines and accessories installed on your boat come with their own operation and maintenance manuals.
- Read these manuals *before* using the engines and accessories.
- Unless noted otherwise, *all* engine and accessory literature referred to in this *Supplement* is included in your owner's packet.

Propellers

 CAUTION
<p>ENGINE DAMAGE HAZARD!</p> <p>The factory standard propellers may not be the best for your particular boat and load conditions. Refer to the engine manual for engine RPM ratings. The engines should reach, but not exceed their full rated RPM when full-throttle is applied.</p> <p>Immediately contact your local Bayliner dealer if:</p> <ul style="list-style-type: none"> • The engines cannot reach their full rated RPM when full-throttle is applied, or; • The engines exceed their full rated RPM when full-throttle is applied.

- Keep the propellers in good repair and at the correct pitch for your particular situation.
- A slightly bent or nicked propeller will adversely affect the performance of your boat.

Qualified Maintenance

 WARNING!
<p>To maintain the integrity and safety of your boat, allow <i>ONLY</i> qualified personnel to perform maintenance on, or in any way modify the:</p> <ul style="list-style-type: none"> • Steering System • Propulsion System • Engine Control System • Fuel System • Environmental Control System • Electrical System • Navigational System

- Failure to maintain your boat's systems (listed in the warning above) as designed could violate the laws in your jurisdiction and could expose you and other people to the danger of bodily injury or accidental death.
- Follow the instructions provided in the *Cruiser & Yacht Owner's Manual*, this *Supplement*, the engine owner's manual and *all* accessory literature.

Safety Standards

⚠ DANGER!



FALLING and ROTATING PROPELLER HAZARD!

- ***NEVER*** allow anyone to ride on parts of the boat ***NOT*** designed for such use.
- Sitting on seat backs, lounging on the forward deck, bow riding, gunwale riding or occupying the transom platform while underway is especially hazardous and ***WILL*** cause personal injury or death.

⚠ DANGER!





FALLING, ROTATING PROPELLER and CARBON MONOXIDE POISONING HAZARD!

- ***NEVER*** allow anyone to occupy, or hang from, the back deck or swim platform while the engine(s) are running.
- Teak surfing, dragging, or water skiing within 20 feet of a moving watercraft can be fatal.

⚠ DANGER!

PERSONAL SAFETY HAZARD!

- ***ALWAYS*** secure the anchor and other loose objects ***BEFORE*** getting underway.
- The anchor and other items that are ***NOT*** properly secured can come loose when the boat is moving and cause personal injury or death.

⚠ WARNING!

A wide variety of components used on this vessel contain or emit chemicals known to the State of California to cause cancer and birth defects and other reproductive harm.

Examples Include:

- Engine and generator exhaust
- Engine and generator fuel, and other liquids such as coolants and oil, especially used motor oil
- Cooking fuels
- Cleaners, paints, and substances used for vessel repair
- Waste materials that result from wear of vessel components
- Lead from battery terminals and from other sources such as ballast or fishing sinkers

To Avoid Harm:

- Keep away from engine, generator, and cooking fuel exhaust fumes.
- Wash exposed skin thoroughly with soap and water after handling the substances above.

- Your boat's mechanical and electrical systems were designed to meet safety standards in effect at the time it was built.
- Some of these standards were mandated by law, all of them were designed to insure your safety, and the safety of other people, vessels and property.

In addition to this *Supplement*, please read the *Cruiser & Yacht Owner's Manual* and ***all*** accessory instructions for important safety standards and hazard information.

Special Care For Moored Boats

NOTICE

- To help seal the hull bottom and reduce the possibility of gelcoat blistering on moored boats, apply an epoxy barrier coating. The barrier coating should be covered with several coats of anti-fouling paint.
- Many states regulate the chemical content of bottom paints in order to meet environmental standards. Check with your local dealer about recommended bottom paints, and about the laws in effect in your area.

- Whether moored in saltwater or freshwater, your boat *will* collect marine growth on its hull bottom.
- This *will* detract from the boat's beauty, greatly affect its performance and may damage the gelcoat.
- There are two methods of slowing marine growth:
 1. Periodically haul the boat out of the water and scrub the hull bottom with a bristle brush and a solution of soap and water.
 2. Occasionally re-paint the hull below the waterline with a good grade of anti-fouling paint.

Sacrificial Anode (Zinc)

NOTICE

- Do *NOT* paint between the zinc and the metal surface it contacts and do *NOT* paint over the zinc.
- If the zinc is *NOT* bonded correctly, it will *NOT* provide protection.

Your boat is equipped with a sacrificial anode (zinc) to protect underwater metal parts from excessive deterioration. Check the zinc regularly and replace it if it has deteriorated more than 70%.

Many factors affect the rate at which the zinc deteriorates, including:

- Water temperature
- Salinity
- Water pollution
- Stray Electrical current

Stray electrical current from your boat, another boat, or the dock may cause complete deterioration of the zinc in just a few weeks. If there is rapid zinc deterioration, measure the electrolytic corrosion around your boat with a corrosion test meter.



NEW SACRIFICIAL ANODE

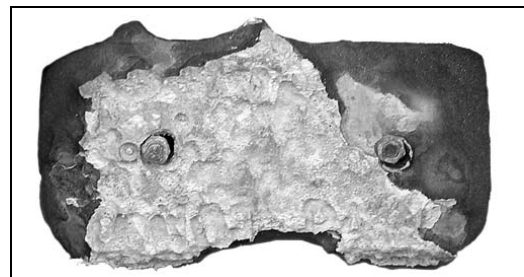

DETERIORATED SACRIFICIAL ANODE

Boat Lifting

! WARNING!

PERSONAL INJURY and/or PRODUCT OR PROPERTY DAMAGE HAZARD!

- Lifting slings may slip on the hull.
- Avoid serious injury or death by securing the lifting slings together **BEFORE** lifting.

! WARNING!

PERSONAL INJURY and/or PRODUCT OR PROPERTY DAMAGE HAZARD!

- **NEVER** lift any boat using the cleats, or the bow and stern eyes.

! WARNING!

PERSONAL INJURY and/or PRODUCT or PROPERTY DAMAGE HAZARD!

- Water in the bilge can shift and change the balance of the load.
- If water is present in the bilge, pump or drain the water out of the bilge areas **BEFORE** lifting your boat.

! CAUTION

PRODUCT or PROPERTY DAMAGE HAZARD!

- When lifting any boat, **ALWAYS** use a spreader bar. The spreader bar **MUST** be equal to the width of the boat at each lifting point.

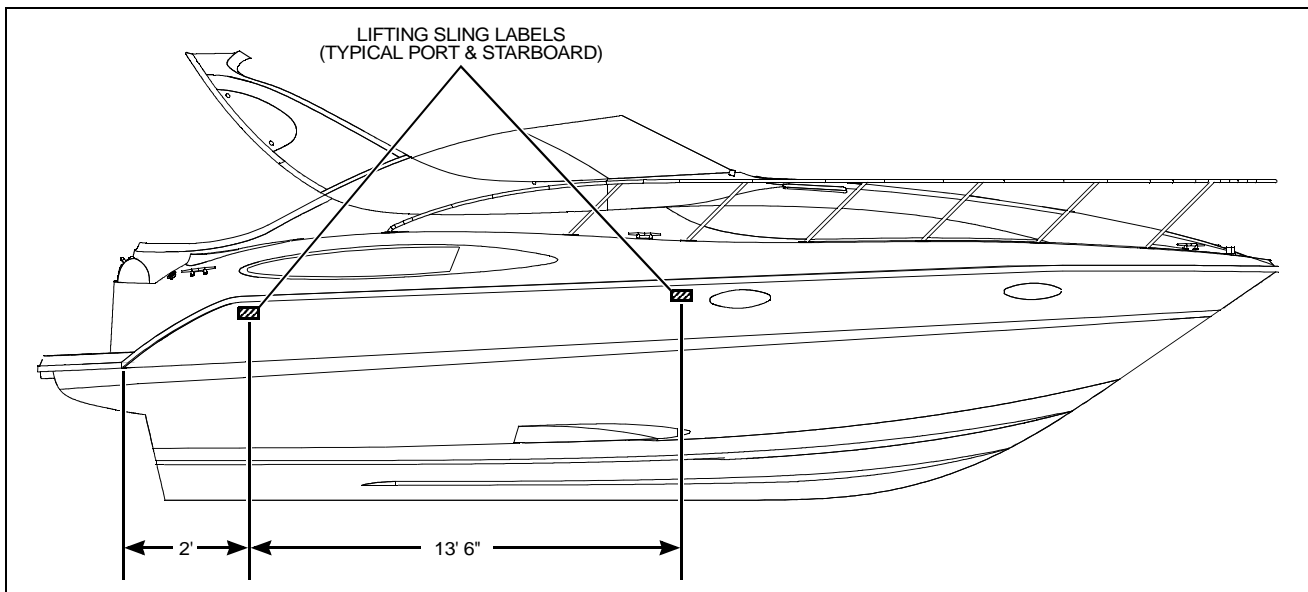

- **Always** follow the lift equipment's instructions and requirements.
- Water in the bilge can shift and change the balance of the load.
- If water is present in the bilge, pump or drain the water out of the bilge areas **before** lifting your boat.
- When lifting your boat, **always** position the lifting slings at the port and starboard lifting sling label positions as shown in the illustration.

Carbon Monoxide (CO)

⚠ DANGER!	
	<ul style="list-style-type: none"> • Carbon monoxide gas (CO) is colorless, odorless, tasteless, and extremely dangerous. • <i>All</i> engines, generators, and fuel burning appliances produce CO as exhaust. • Prolonged exposure to low concentrations or very quick exposure to high concentrations <i>WILL</i> cause <i>BRAIN DAMAGE</i> or <i>DEATH</i>. • Teak surfing, dragging, or water skiing within 20 feet of a moving watercraft can be fatal.

CO Facts

- CO poisoning causes a significant number of boating deaths each year.
- Called the "silent killer", CO is an extremely toxic, colorless, odorless and tasteless gas.
- CO can harm or even kill you inside or outside your boat.
- CO can affect you whether you're underway, moored, or anchored.
- CO symptoms are similar to seasickness or alcohol intoxication.
- CO can make you sick in seconds. In high enough concentrations, even a few breaths can be fatal.
- Breathing CO blocks the ability of your blood to carry oxygen.
- The effects are cumulative. Even low levels of exposure can result in injury or death.

Factors that Increase the Effects of CO Poisoning

- Age
- Smokers or people exposed to high concentrations of cigarette smoke
- Consumption of alcohol
- Lung disorders
- Heart problems
- Pregnancy

Where and How CO Can Accumulate

Stationary Conditions That Increase CO Accumulations Include:

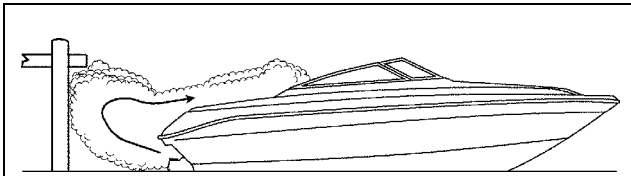

A. Using engine, generator, or other fuel burning device when boat is moored in a confined space.

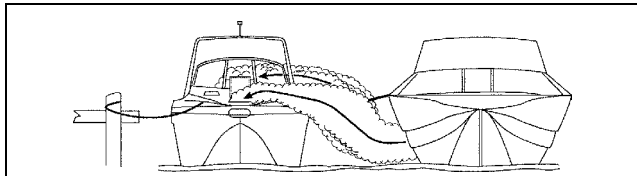

B. Mooring too close to another boat that is using its engine, generator, or other fuel burning device.

To correct stationary situations A and/or B:

- **Close all** windows, portlights and hatches.
- If possible, move your boat away from source of CO.

Running Conditions That Increase CO Accumulations Include:

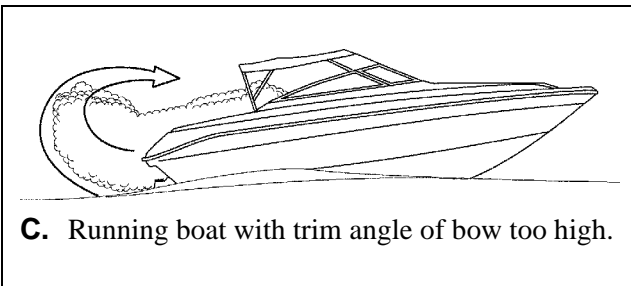

C. Running boat with trim angle of bow too high.

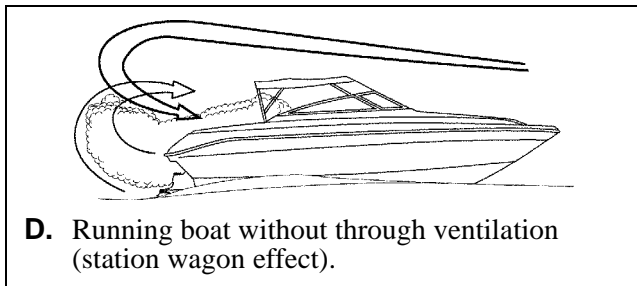

D. Running boat without through ventilation (station wagon effect).

To correct running situations C and/or D:

- Trim bow down.
- **Open** windows and canvas.
- When possible, run boat so that prevailing winds help dissipate exhaust.

How to Protect Yourself and Others From CO

- Know where and how CO may accumulate in and around your boat (see above).
- Maintain fresh air circulation throughout the boat at **all** times.
- Know where your engine and generator exhaust outlets are located and keep everyone away from these areas.
- **Never** sit on, or hang onto, the back deck or swim platform while the engines are running.
- **Never** enter the areas under swim platforms where exhaust outlets are located.
- Although CO can be present without the smell of exhaust fumes, if exhaust fumes are detected on the boat, take **immediate** action to dissipate these fumes.
- Treat symptoms of seasickness as possible CO poisoning. Get the person into fresh air **immediately**. Seek medical attention—unless you're sure it's not CO.
- Install and maintain CO monitors inside your boat. Do **not** ignore any alarm. Replace monitors as recommended by the monitor manufacturer.
- Follow the checklists provided on the next page.
- Get a Vessel Safety Check.

For information on how to get a free VESSEL SAFETY CHECK, visit www.vesselsafetycheck.org or contact your local U.S. Coast Guard Auxiliary or United States Power Squadrons®.

- U.S. Coast Guard Auxiliary: 1-800-368-5647 or on the Internet at: <http://www.cgaux.org>
- U.S. Power Squadrons: 1-888-FOR-USPS (1-888-367-8777) or on the Internet at: <http://www.usps.org>

CO Checklists

Trip Checklist

- Make sure you know where the exhaust outlets are located on your boat.
- Educate *all* passengers about the symptoms of CO poisoning and where CO may accumulate.
- When docked, or rafted with another boat, be aware of exhaust emissions from the other boat.
- Listen for any change in exhaust sound, which could indicate an exhaust component failure.
- Test the operation of each CO monitor by pressing the test button.

Monthly Checklist

- Make sure *all* exhaust clamps are in place and secure.
- Look for exhaust leaking from exhaust system components. Signs include rust and/or black streaking, water leaks, or corroded or cracked fittings.
- Inspect rubber exhaust hoses for burned, cracked, or deteriorated sections. *All* rubber hoses should be pliable and free of kinks.

Annual Checklist

Have a Qualified Marine Technician:

- Replace exhaust hoses if cracking, charring, or deterioration is found.
- Ensure that your engines and generators are properly tuned, and well maintained.
- Inspect each water pump impeller and the water pump housing. Replace if worn. Make sure cooling systems are in working condition.
- Inspect *all* metallic exhaust components for cracking, rusting, leaking, or loosening. Make sure they check the cylinder head gasket, exhaust manifold, water injection elbow, and the threaded adapter nipple between the manifold and the elbow.
- Clean, inspect, and confirm proper operation of the generator cooling water anti-siphon valve (if equipped).

CO Monitor

NOTICE

- The stereo memory and the CO monitor place a small, but constant drain on the battery.
- If your boat will be unattended for an extended amount of time, plug into shore power with the battery charger turned *On*.

- Do *not* disconnect the CO monitor.
- Read the manufacturer's instructions for your CO monitor. **If you did not receive the manufacturer's instructions, call (800) 383-0269 and one will be mailed to you.**

If your boat is *not* equipped with a CO monitor, consider purchasing one from your dealer or marine supply store.

More Information

For more information about how you can prevent carbon monoxide poisoning on recreational boats and other ways to boat more safely, contact:

United States Coast Guard
Office of Boating Safety (G-OPB-3)
2100 Second Street SW
Washington, DC 20593
www.uscgboating.org
1-800-368-5647

National Marine Manufacturers
Association (NMMA)
200 East Randolph Drive
Suite 5100
Chicago, IL 60601-9301
www.nmma.org
312-946-6200

American Boat & Yacht Council, Inc.
(ABYC)
3069 Solomon's Island Road
Edgewater, MD 21037-1416
www.abycinc.org
410-956-1050

For information on how to get a free VESSEL SAFETY CHECK, visit www.vesselsafetycheck.org or contact your local U.S. Coast Guard Auxiliary or United States Power Squadrons®.

- U.S. Coast Guard Auxiliary: 1-800-368-5647 or on the Internet at: <http://www.cgaux.org>
- U.S. Power Squadrons: 1-888-FOR-USPS (1-888-367-8777) or on the Internet at: <http://www.usps.org>

Chapter 2: Locations

Exterior Views

Hull Views

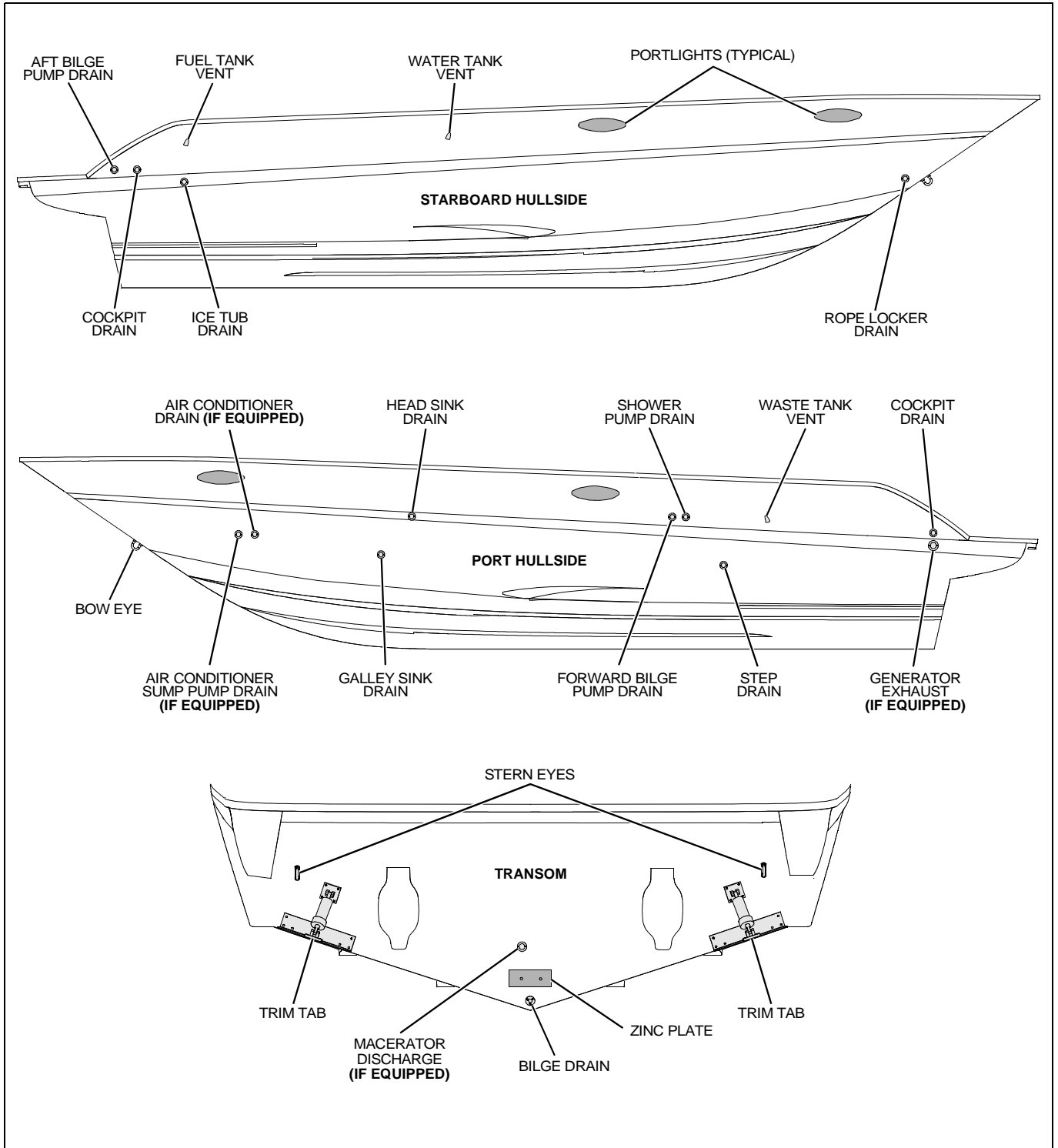

Forward Deck View

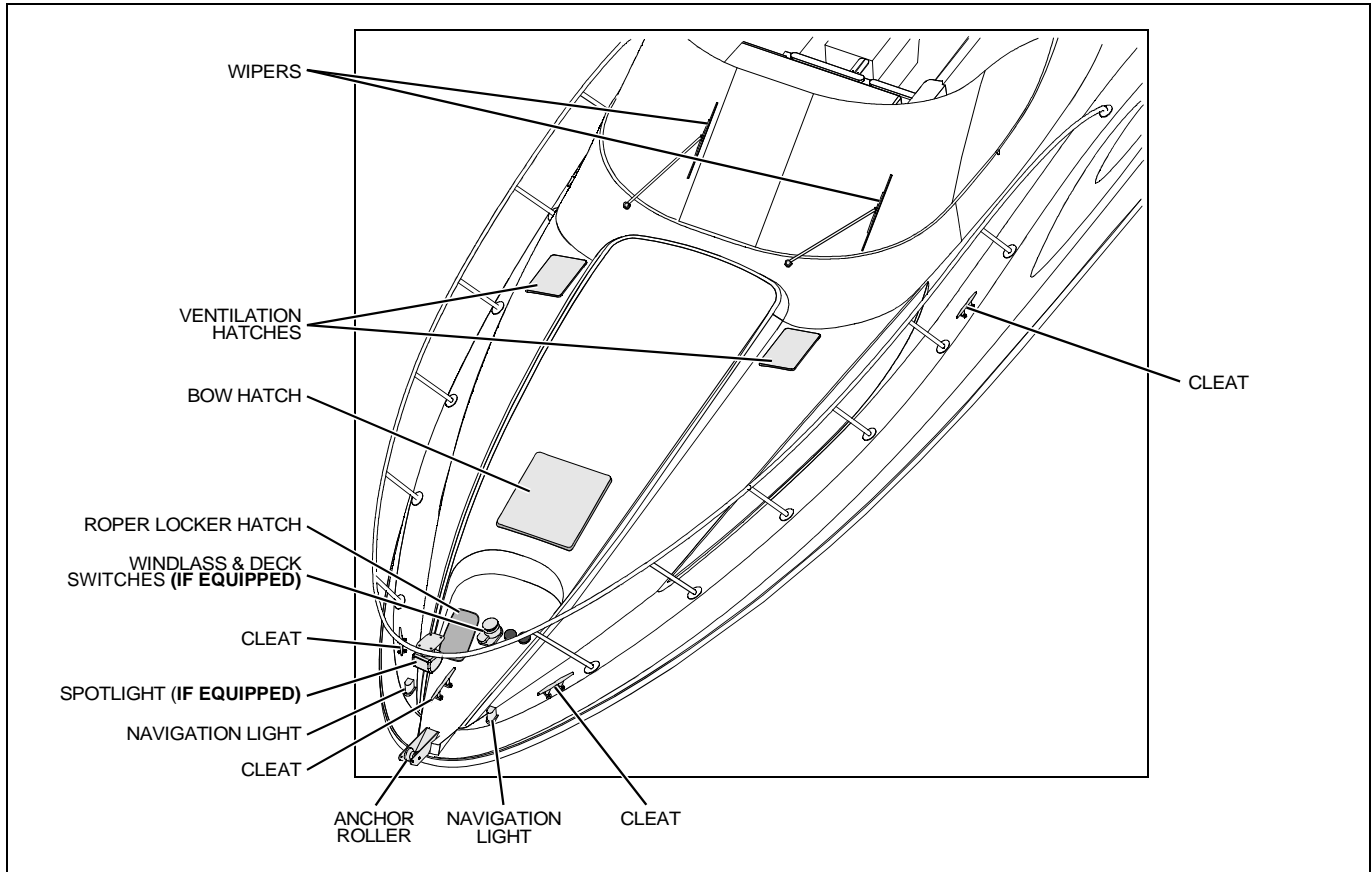

Aft Deck View

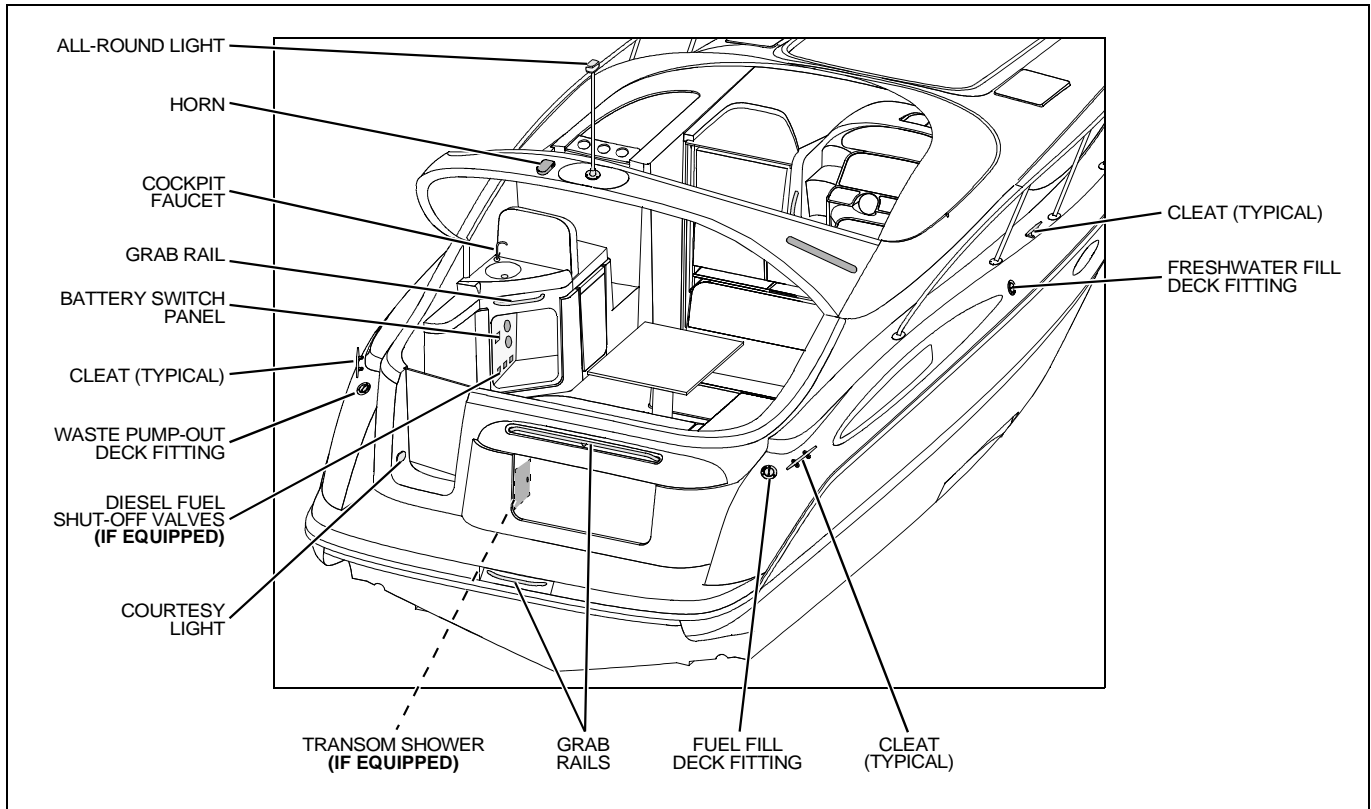

Helm Station

NOTE: TYPICAL HELM LAYOUT SHOWN. ACTUAL LAYOUT MAY VARY DEPENDING ON ENGINE AND ACCESSORY OPTIONS.

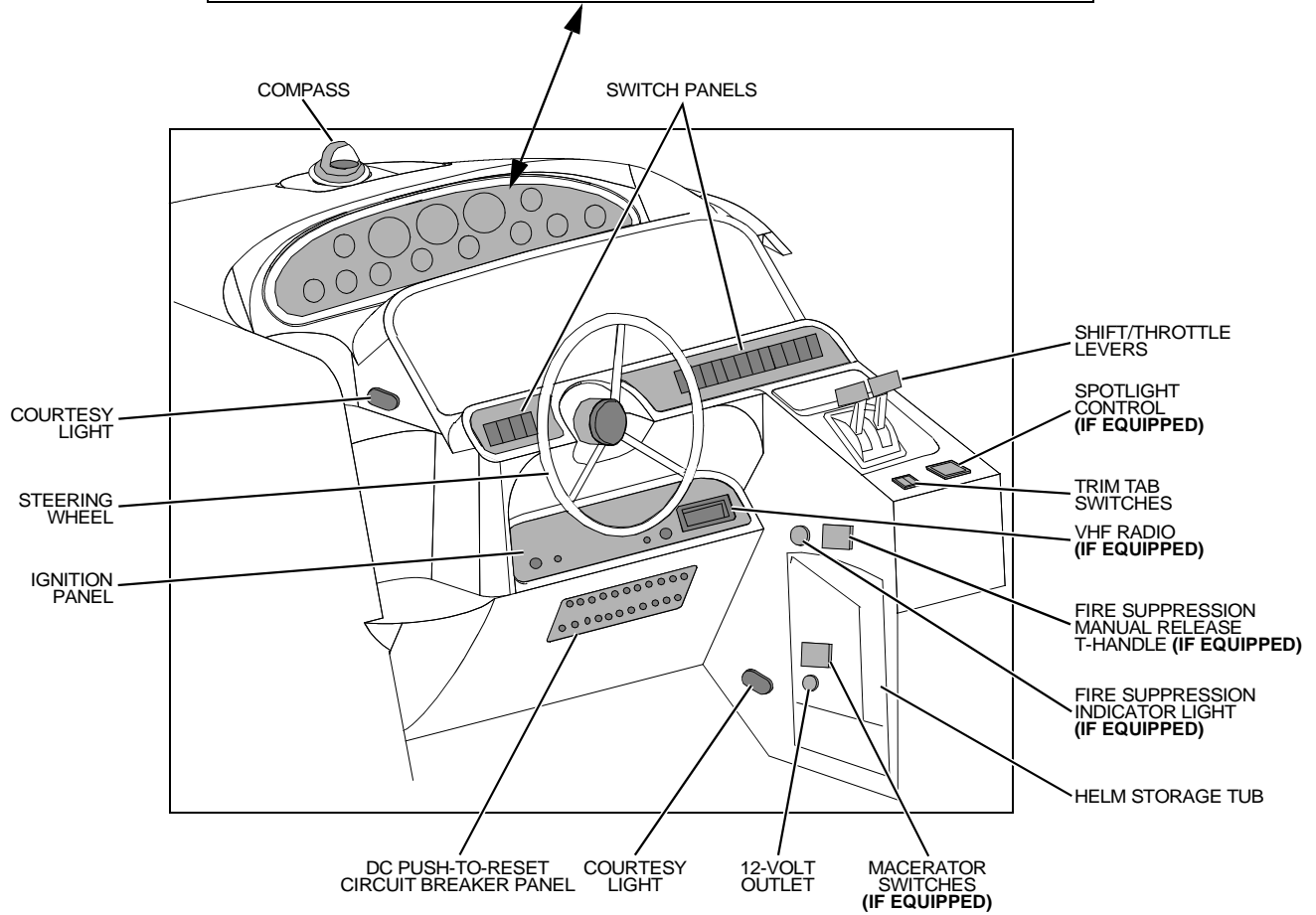
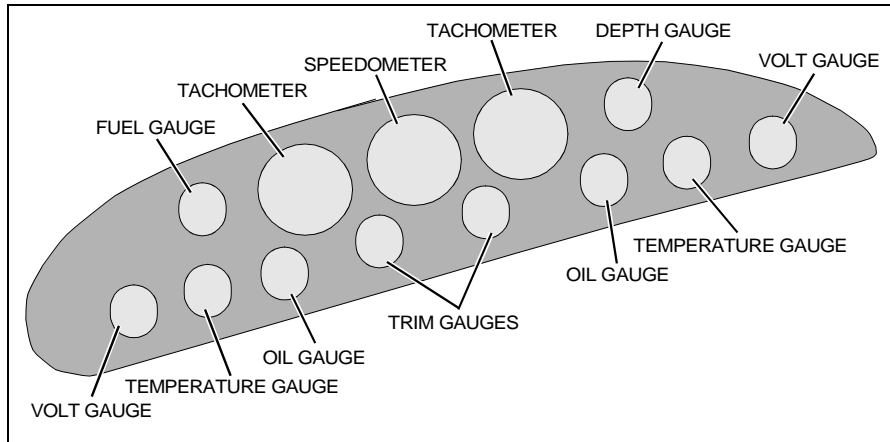

Component Locations

12-Volt Accessory Outlets:

- One is located inside the helm storage tub.

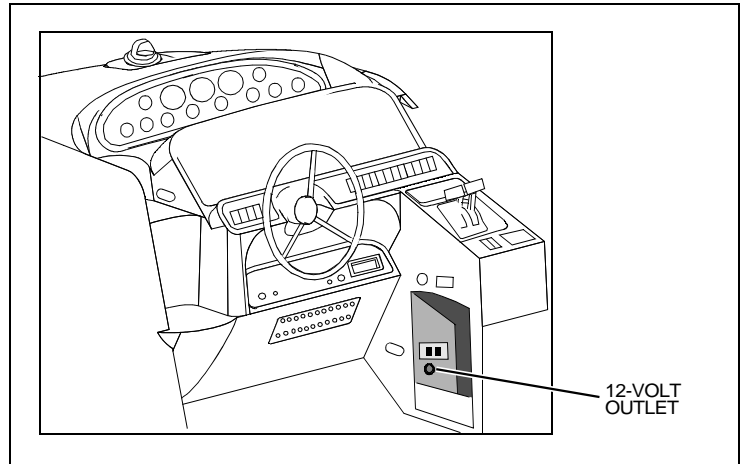

- One is located inside the forward upper galley cabinet.

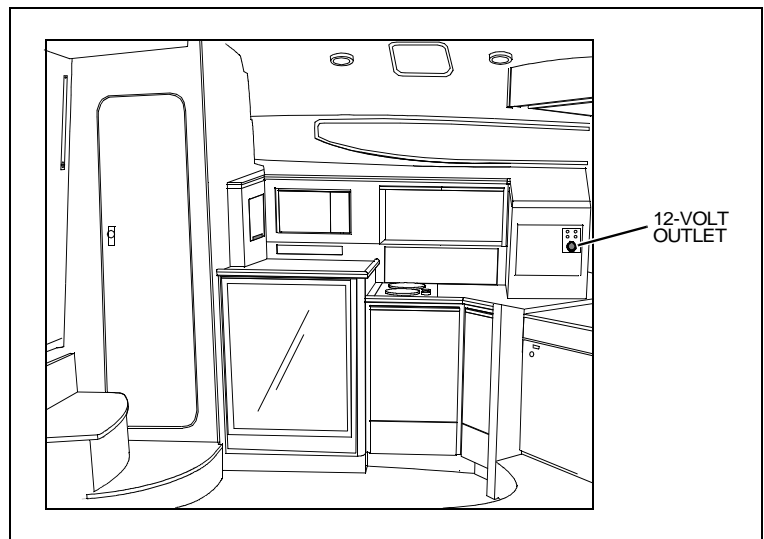

12-Volt DC Fuses: Located on the battery switch panel inside the cockpit entertainment center cabinet.

12-Volt DC Push-to-Reset Circuit Breakers:

- DC push-to-reset circuit breakers for accessories are located below the helm.
- DC main accessory push-to reset circuit breaker is located on the battery switch panel.

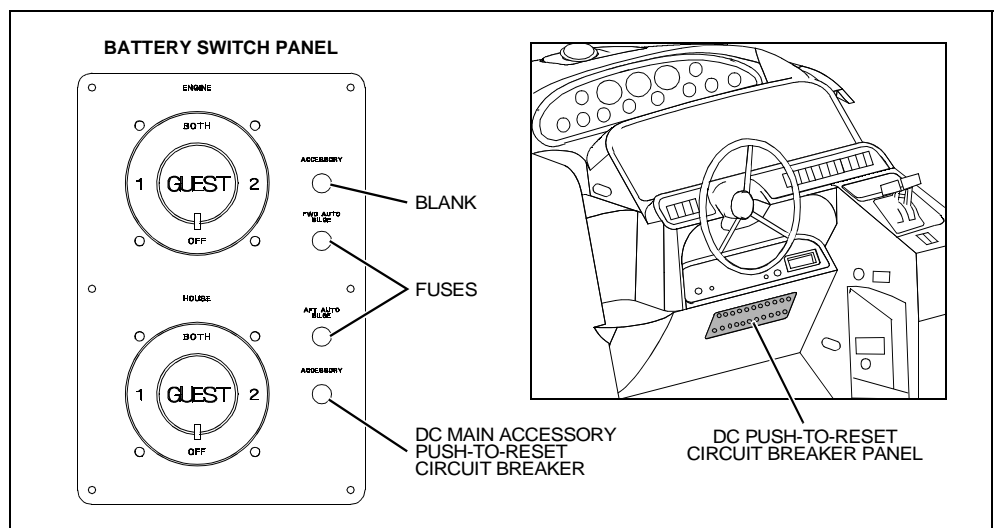

110-Volt AC Master Electrical Panel: Located on the aft wall of the galley.

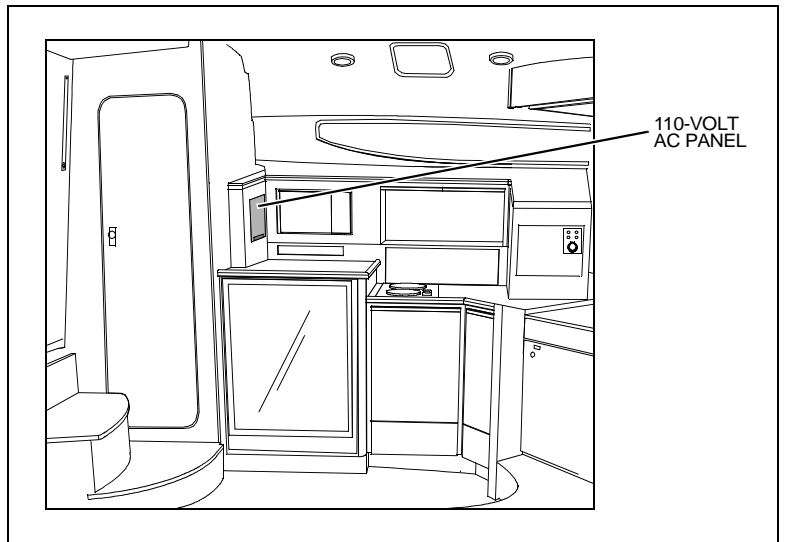

Air Conditioner Intake Pump (If Equipped):

- Located in the utility room.
- Access is through the wall hatch on the port side of the aft berth.

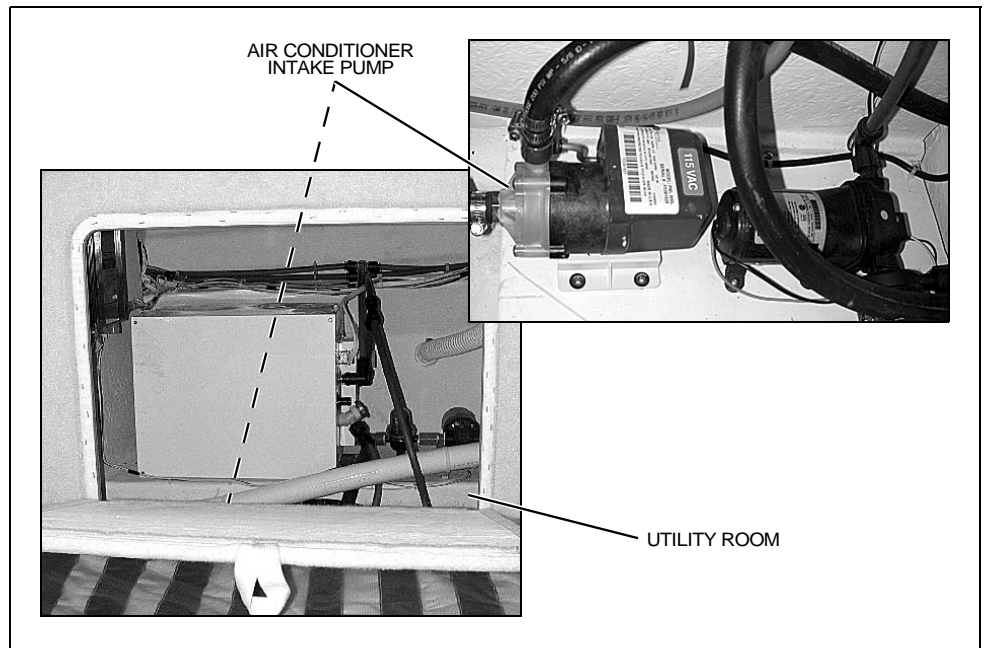

Air Conditioner Seawater Intake Seacock (If Equipped): Located in the engine room, forward of the port engine.

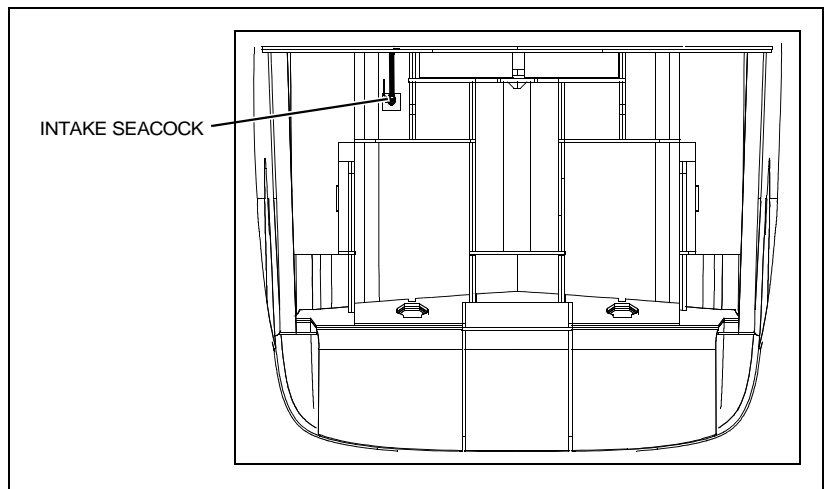

Air Conditioner Unit (If Equipped):

- Located under the v-berth mattress.
- Access is through the center v-berth hatch.

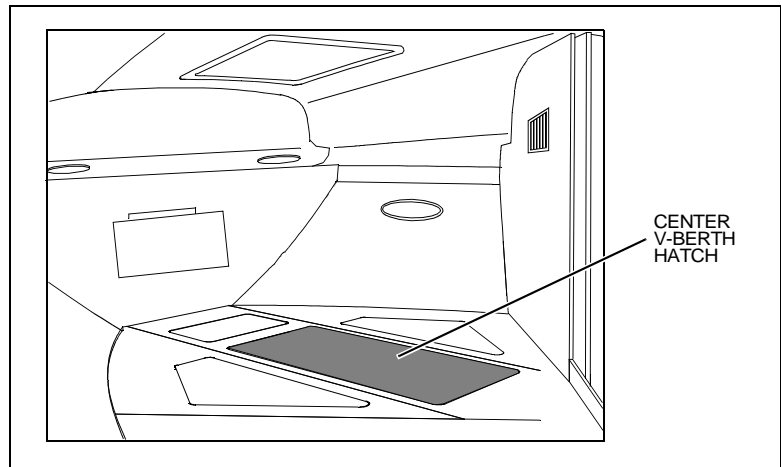

Batteries: Located in the starboard forward area of the engine room.

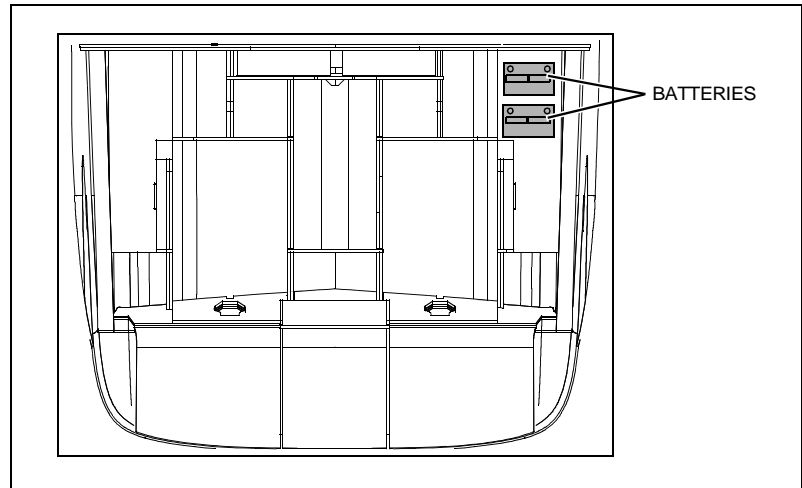
**Battery Charger:**

- Located in the utility room.
- Access is through the wall hatch on the port side of the aft berth.

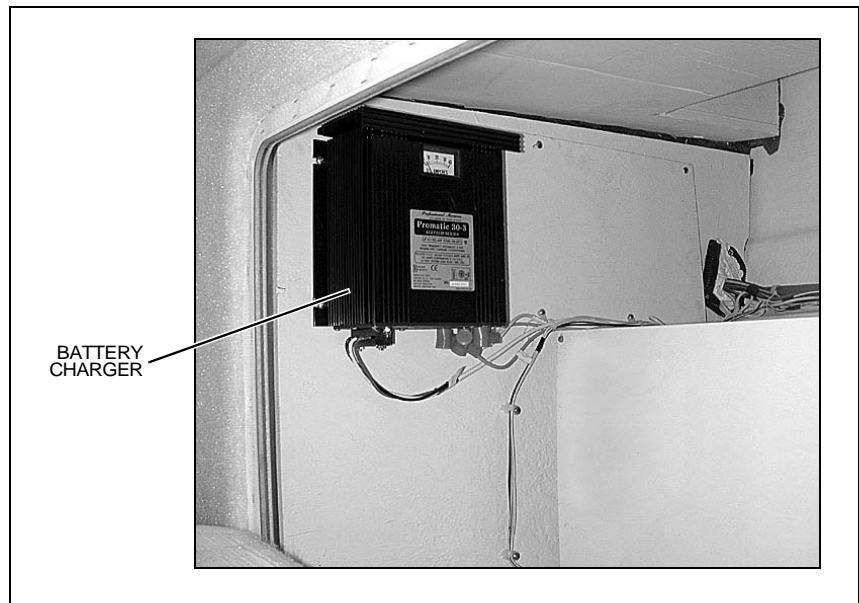

Battery Switch Panel: Located inside the cockpit entertainment center cabinet.

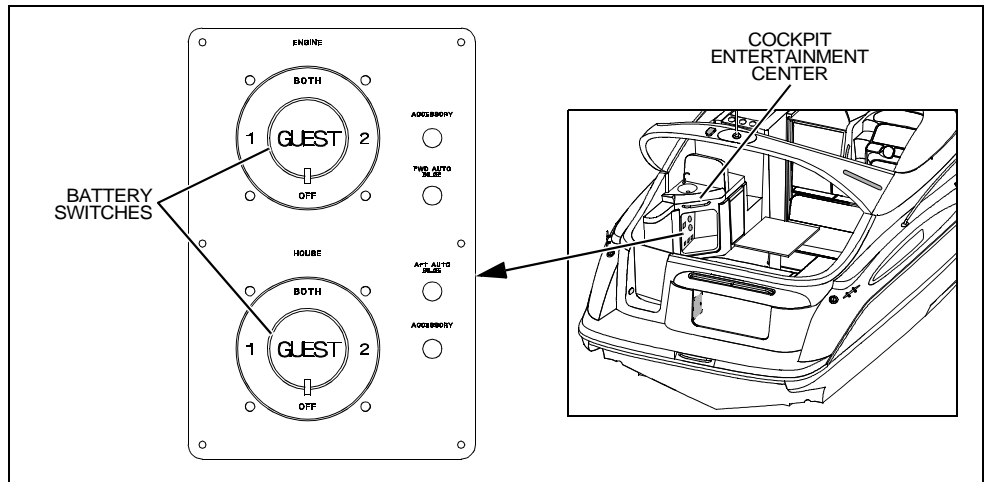

Bilge Pump & Float Switch - Aft: Located next to the transom wall in the center of the engine room bilge.

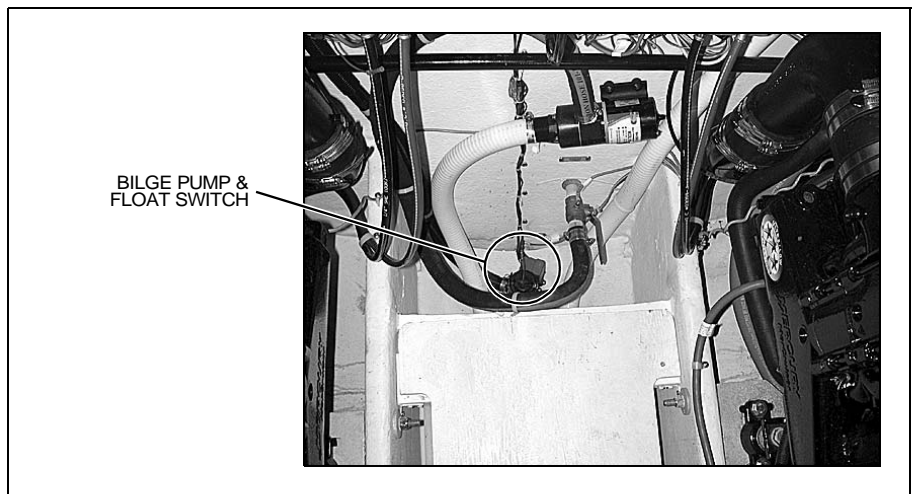

Bilge Pump & Float Switch - Forward:

- Located in the bilge area under the entry stairs.
- Access by lifting up the top step.

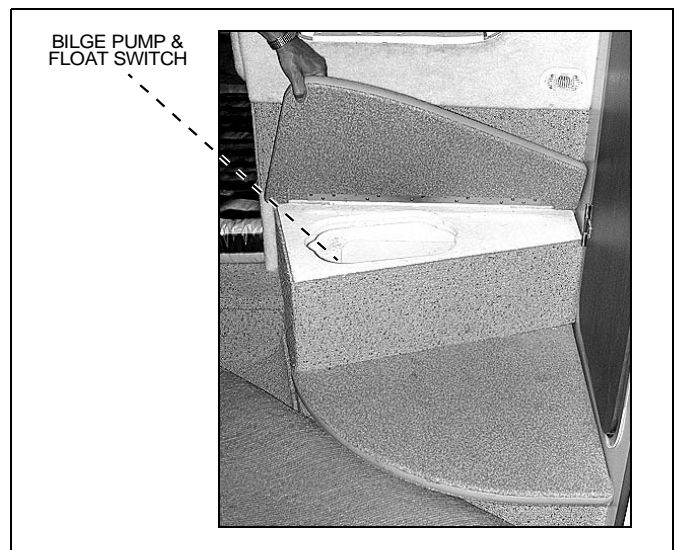

CO Monitor: Located on the starboard aft wall in the dinette area.

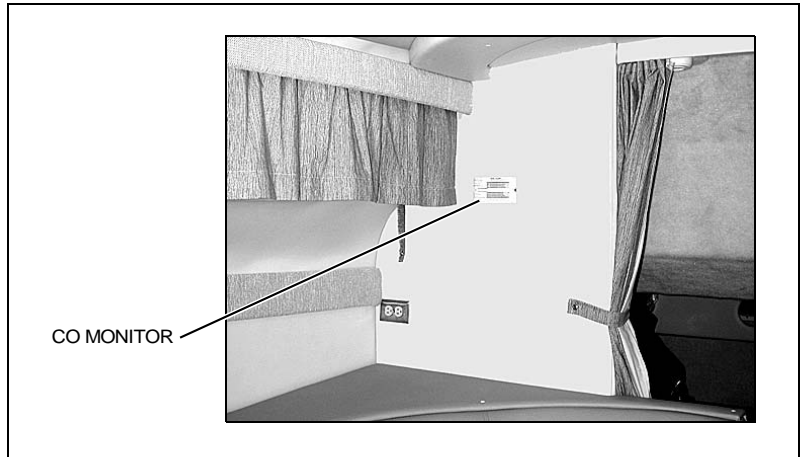

Depth Sounder Thru-hull Transducer: Located in the engine room, forward of the starboard engine.

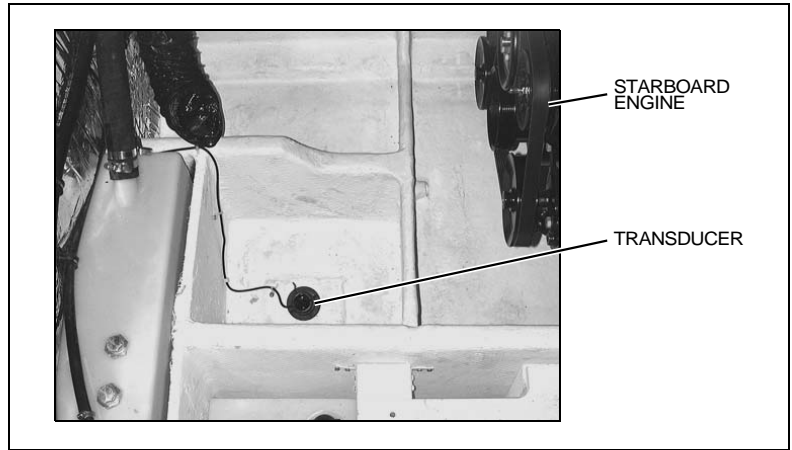

Freshwater Fill Deck Fitting: Located on the starboard deck.

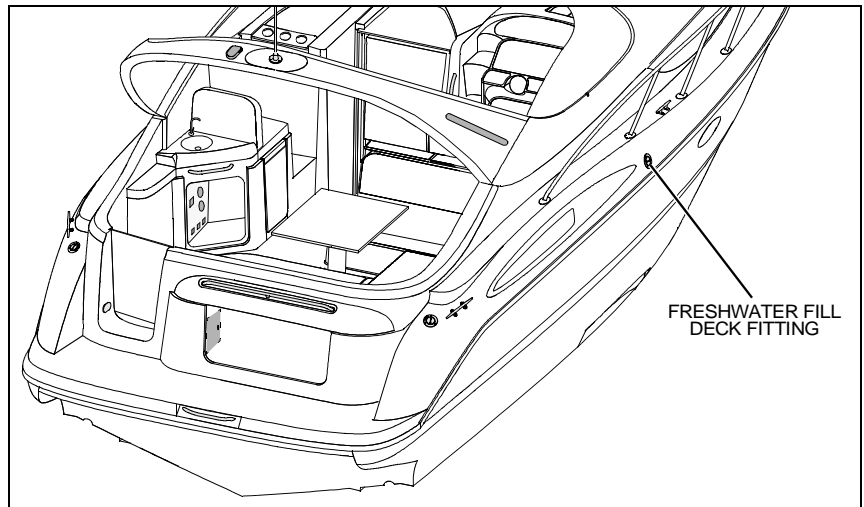

Freshwater Pump:

- Located in the utility room.
- Access is through the wall hatch on the port side of the aft berth.

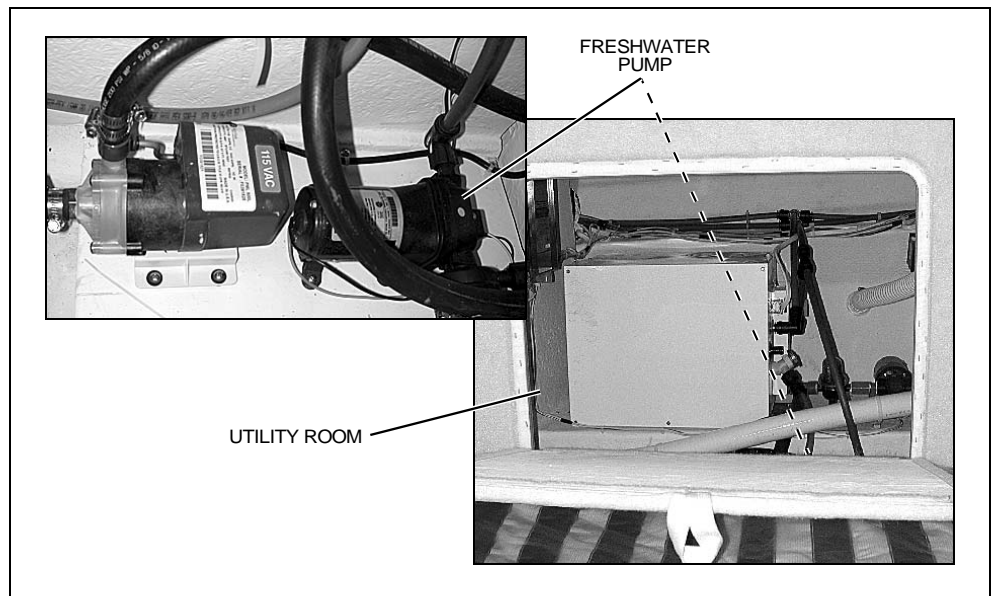

Freshwater Pump Switch: Located in the galley.



Freshwater System Drain Plugs: Located in the port forward area of the engine room.

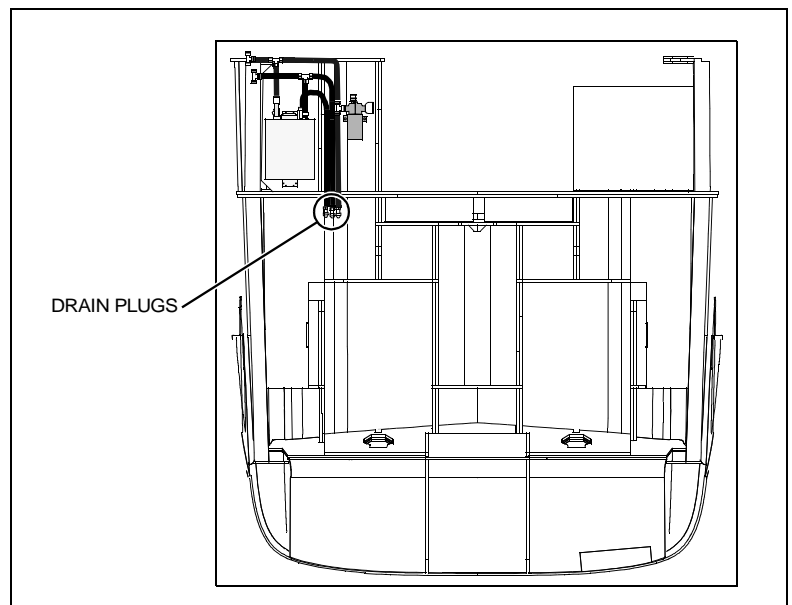

Freshwater Tank:

- Located in the bilge area under the entry steps.
- Access by lifting up the top step.

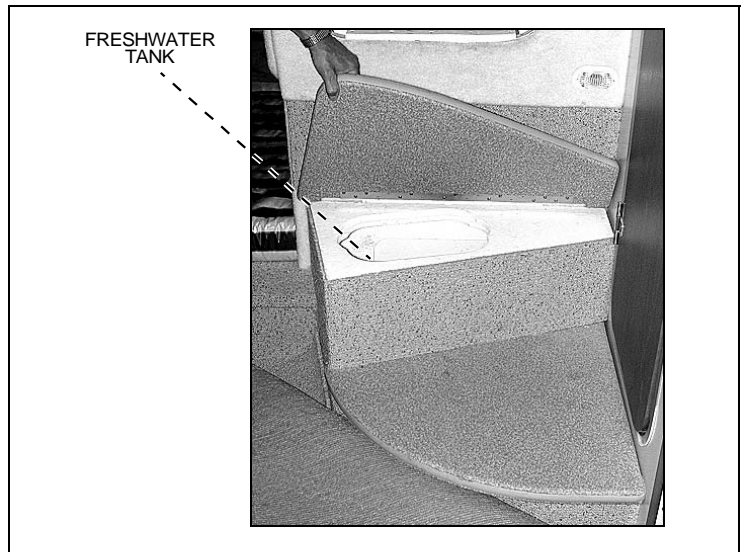

Fuel Fill Deck Fitting: Located on the starboard aft corner of the deck.

Fuel Shut-Off Valves (Diesel Fuel Systems Only): Located inside the cockpit entertainment center cabinet.

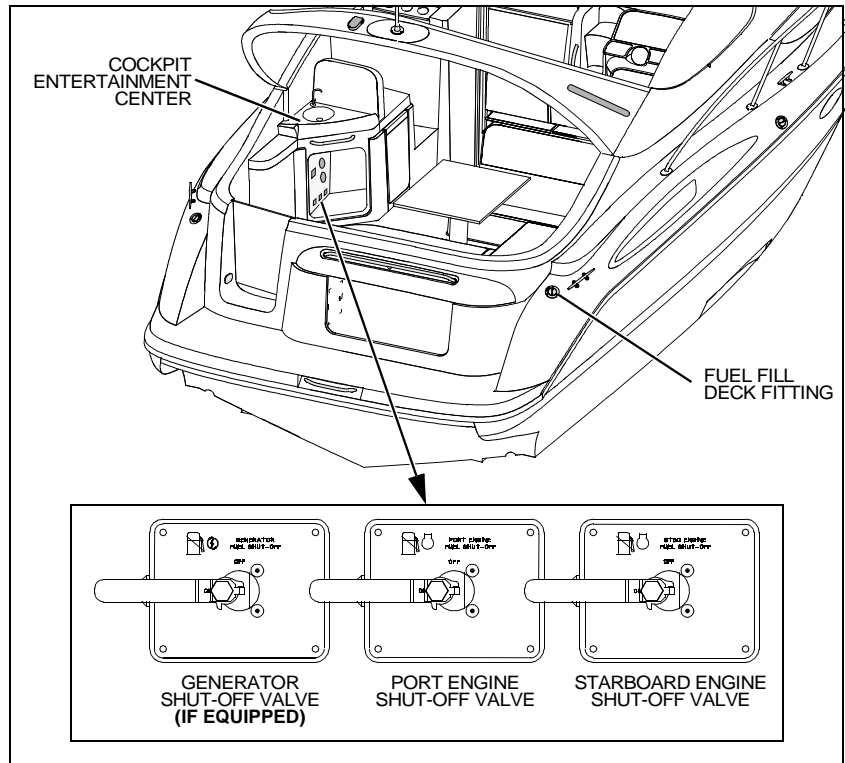

Fuel Tank:

- Located in the bilge under the aft-berth.
- Access to the fuel tank fittings is in the forward area of the engine room.

Generator (If Equipped): Located in the center of the engine room.

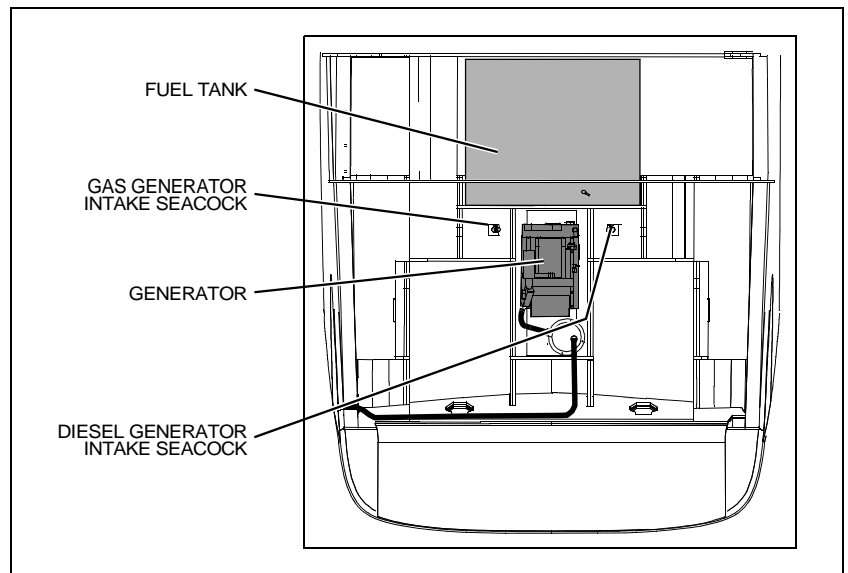

Generator Control Panel & Gauges (If Equipped): Located below the 110-volt AC master panel in the galley



Generator Seawater Intake Seacock (If Equipped):

- Gas Generator Intake Seacock: Located forward of the port engine.
- Diesel Generator Intake Seacock: Located forward of the starboard engine.

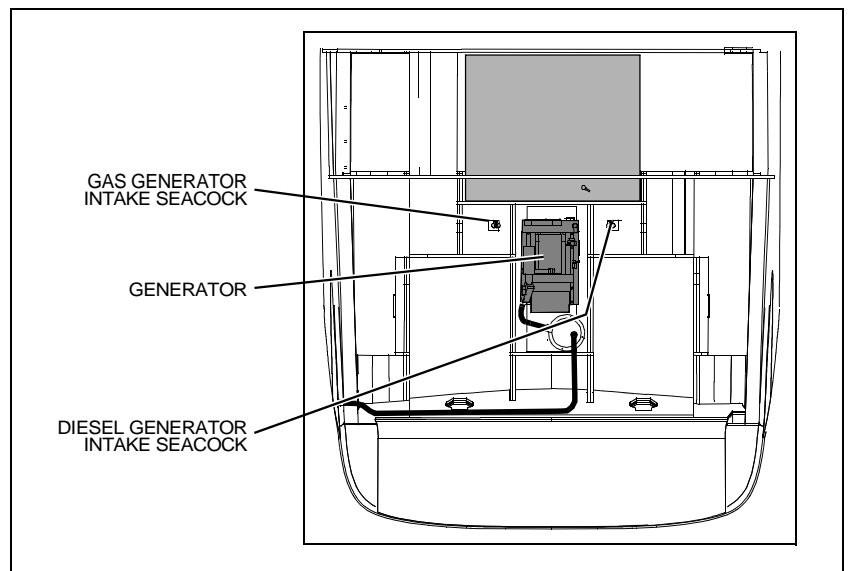

Macerator & Macerator Discharge Seacock (If Equipped): Located on the transom wall in the aft area of the engine room.

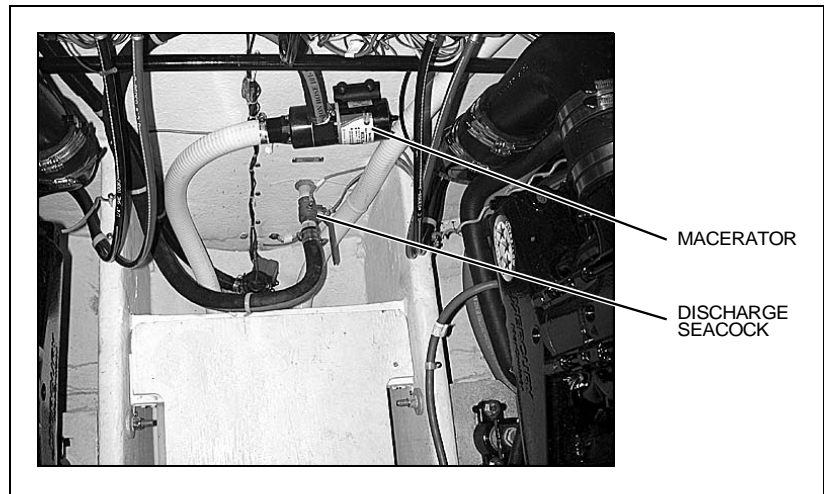

Marine Head Seawater Intake Seacock: Located in the engine room, forward of the port engine.

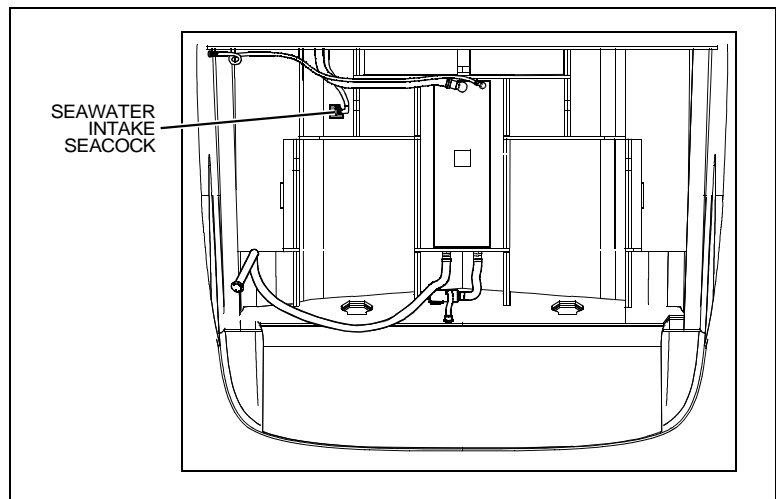

Navigation Lights:

- White all-round light is located on top of the radar wing.
- Red and green lights are located on the bow.

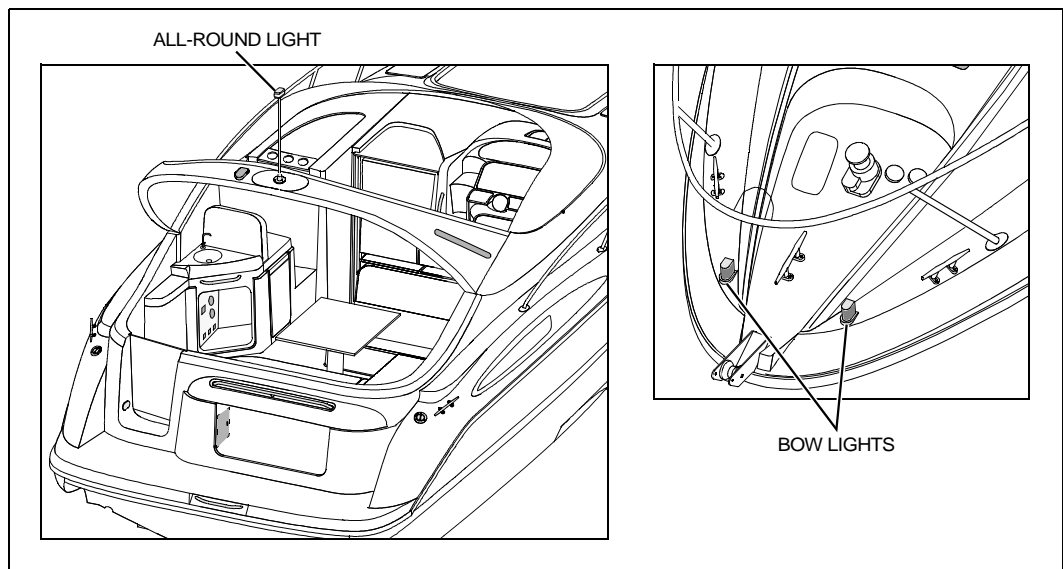

Shower Drain Pump:

- Located in the bilge area under the entry stairs.
- Access by lifting up the top step.

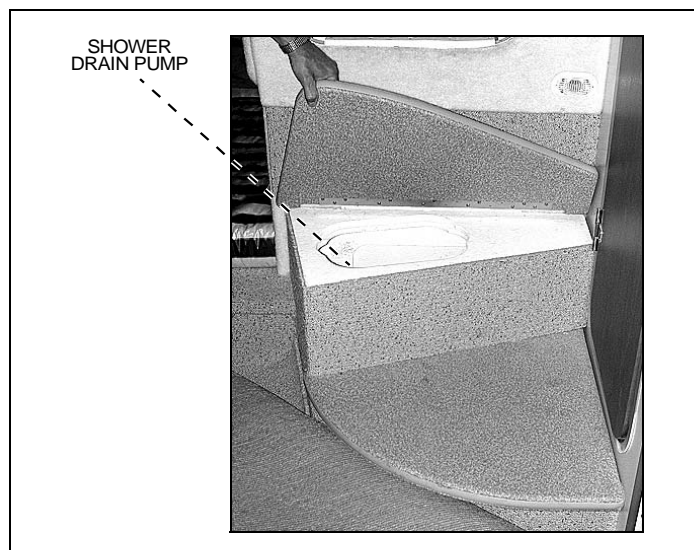

Shower Drain Pump Switch: Located on the head vanity.

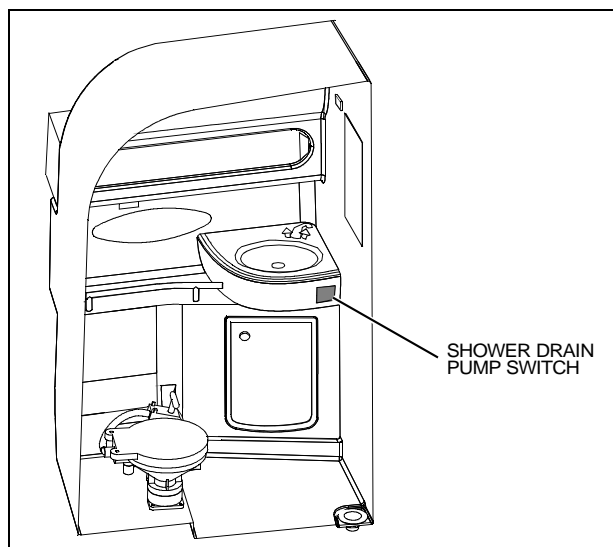

Spotlight (If Equipped): Located on the bow rail.

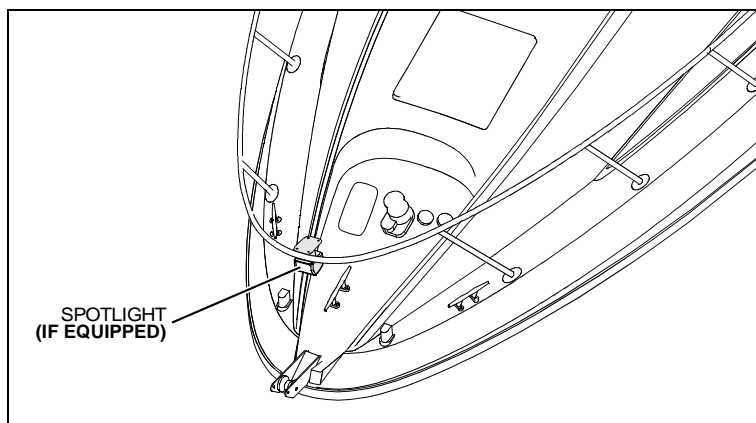

Spotlight Control Panel: Located at the helm, near the shift/throttle levers.

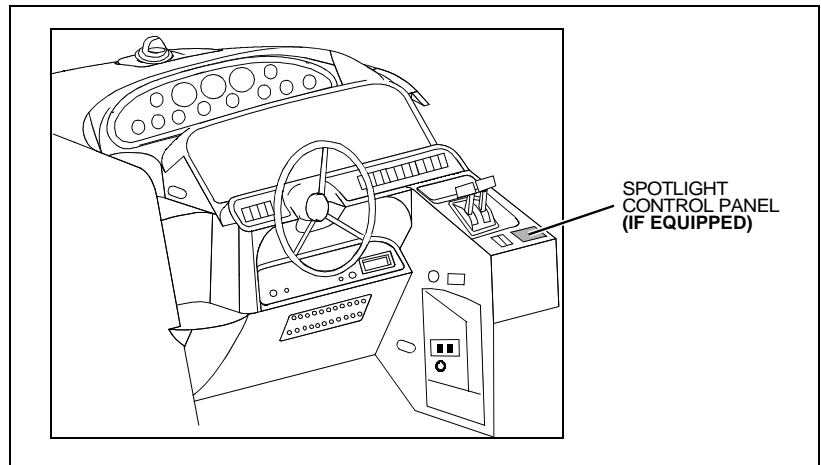

Trim & Tilt Pumps & Reservoirs: Located on the transom wall in the center of the engine room.

Trim Tab Pump & Reservoir: Located on the transom wall in the center of the engine room, in between the trim and tilt pumps.

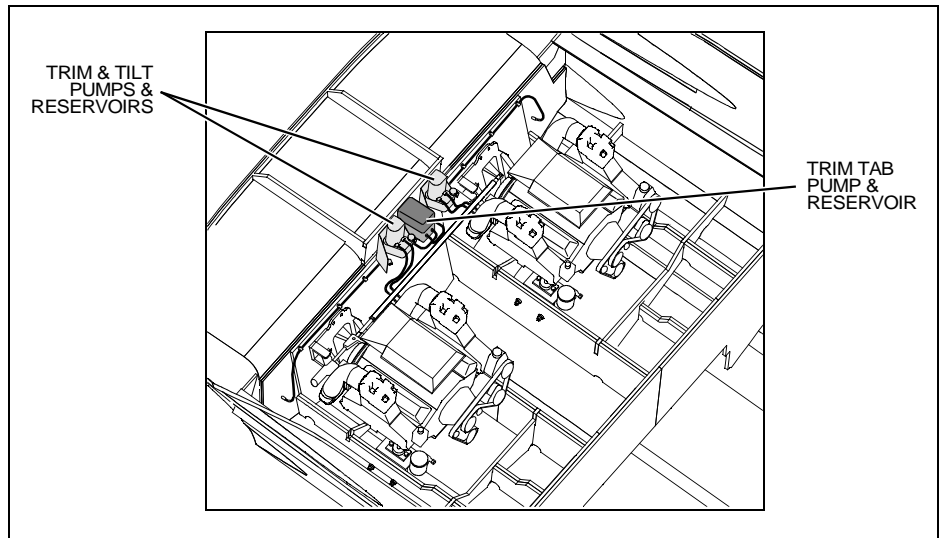

Waste Holding Tank: Located in the center of the engine room.

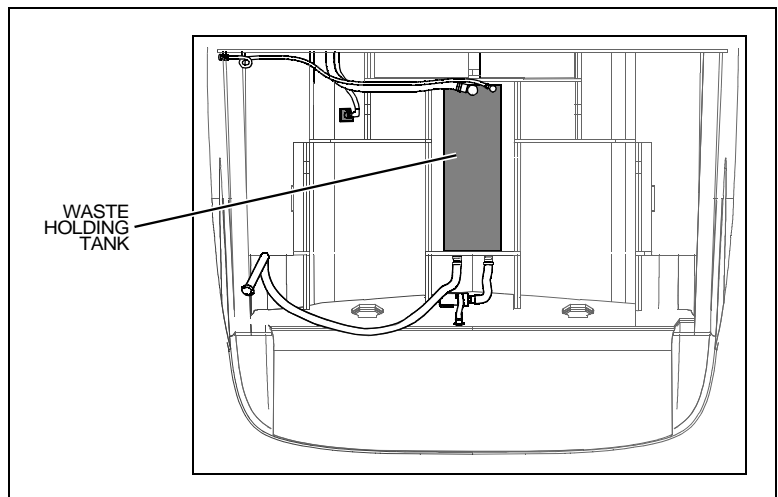

Waste Pump-out Deck Fitting: Located on the port aft deck, next to the transom door.

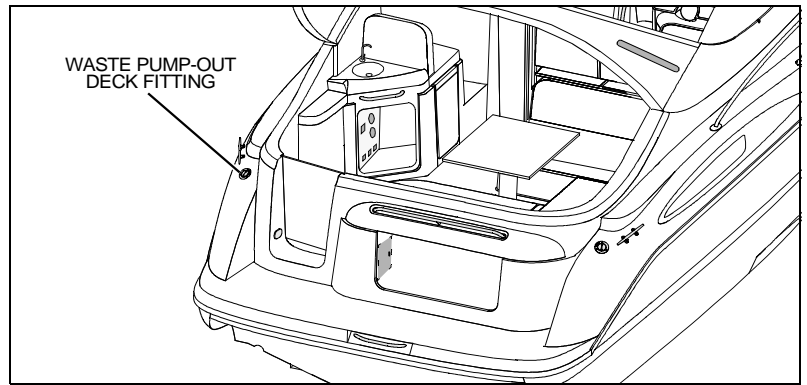

Water Heater:

- Located in the utility room.
- Access is through the wall hatch on the port side of the aft berth.

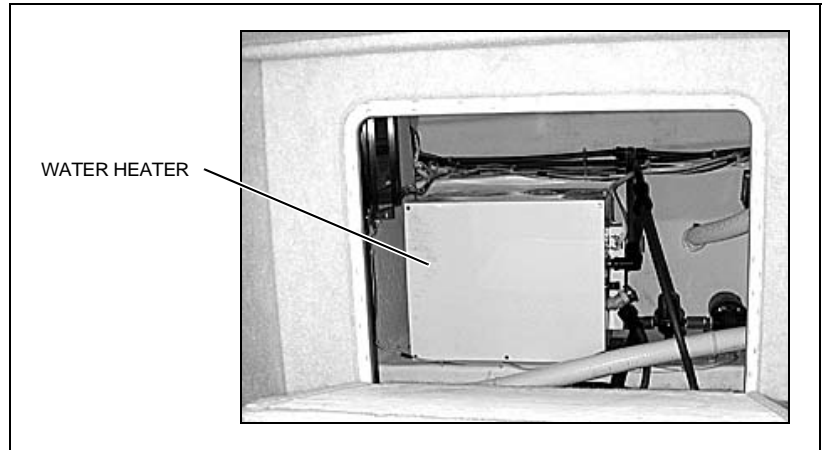

Windlass Circuit Breaker (If Equipped):

Located inside the cockpit entertainment center cabinet.

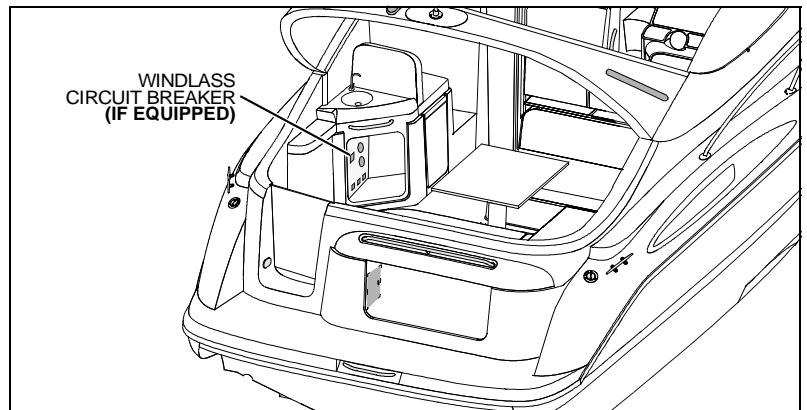

Windlass Foot Controls (If Equipped):

Located on the forward deck.

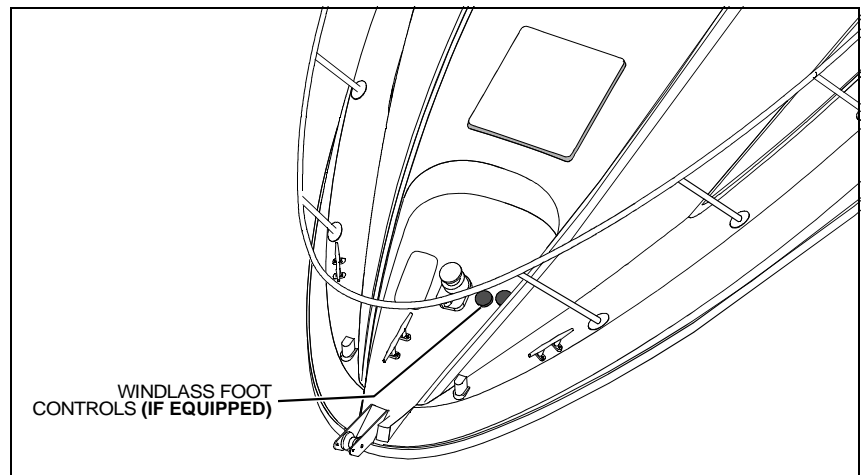

Chapter 3: Propulsion & Related Systems

Engines

Read the engine operation and maintenance manuals *before* starting or working on the engines.

Bilge Blower System

WARNING!



FIRE/EXPLOSION HAZARD

- Use of the bilge blower system is *NOT A GUARANTEE* that explosive fumes have been removed.
- *BEFORE* starting the engines or the generator *ALWAYS* use the "sniff test" to check the engine and bilge areas for fuel vapors.
- If you smell fuel, do *NOT* start the engines or the generator and do *NOT* turn *On* any electrical devices.
- If you smell fuel and the engines and/or generator are already running, shut *Off* the engines and/or generator and turn *Off all* electrical devices. Investigate *immediately*.
- Do *NOT* obstruct or modify the ventilation system.

- The bilge blower system removes explosive fumes from the engine and bilge areas.
- Fresh air is drawn into the engine and bilge areas through the vents.

To make sure the engine and bilge areas are properly ventilated:

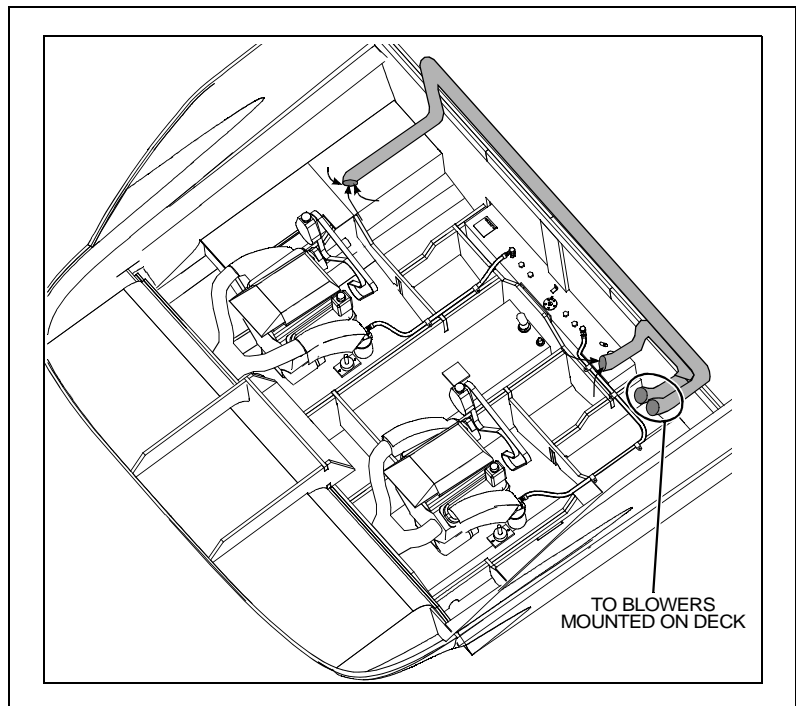
- Use the "sniff test" to check the engine and bilge areas for fuel vapors *before* starting the engines or the generator (if equipped).
- *Always* run the bilge blower system for at least four minutes *before* starting the engines or the generator (if equipped).
- Continue to run the bilge blower system until your boat has reached cruising speed.
- *Always* run the bilge blower system when running the boat below cruising speed.



Fuel System

WARNING!



FIRE, EXPLOSION AND OPEN FLAME HAZARD!

- It is very important that the fuel system be inspected thoroughly the first time it is filled and at each subsequent filling.
- The fueling instructions in the *Cruiser & Yacht Owner's Manual* and the fuel recommendations in the engine operation manual *must* be followed.

CAUTION

Avoid the storage or handling of gear near the fuel lines, fittings and tank.

NOTICE

- On diesel engine models, air in the diesel supply system can stop an engine or severely restrict performance.
- If you suspect air in the fuel lines, refer to your engine operation manual for detailed instructions on how to *bleed* the system.

NOTICE

Carefully read the fuel section of both the *Cruiser & Yacht Owner's Manual* and the engine operation manual, paying special attention to the subject of *fuel recommendations*.

GAS ENGINE FUEL SYSTEMS (IF EQUIPPED)

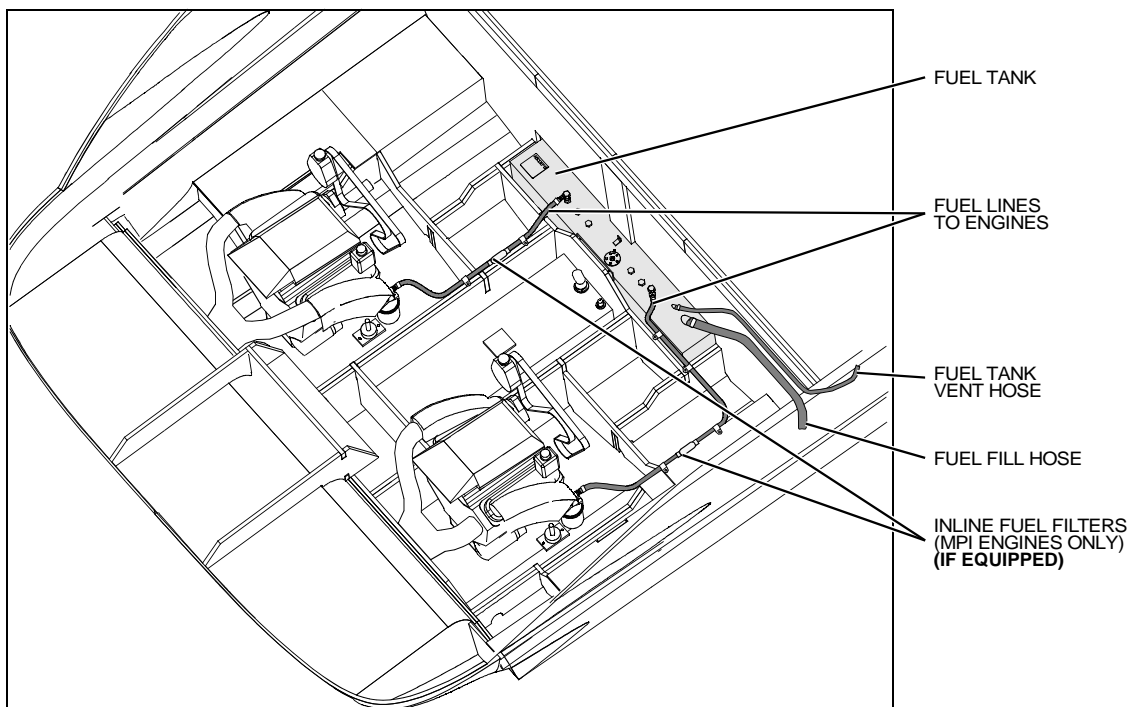

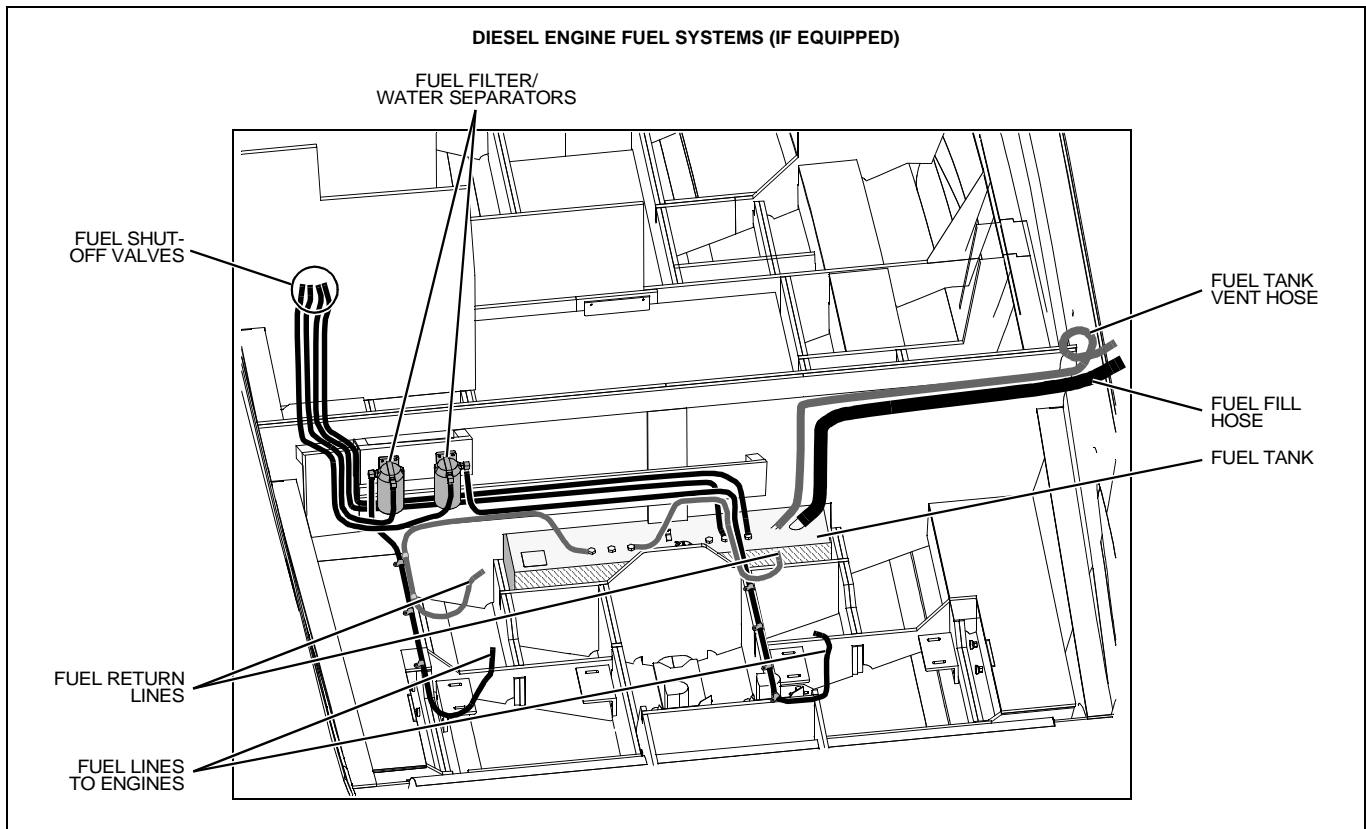

Fuel Fill & Vent

- The fuel fill fitting is marked "Gas" or "Diesel".
- If you have problems filling the fuel tank, see if the fuel fill hose or fuel tank vent hose is kinked or collapsed.
- If there are no visible signs of a problem, contact your local dealer.

Gas Engine Fuel Filters

- The fuel pickup tube, located inside the fuel tank, is equipped with a fine mesh screen filter.
- If your boat features an MPI engine, there may be an inline fuel filter on the fuel line.
- In addition, when supplied by the engine manufacturer, a fuel filter is installed on the engine.
- Periodically replace the fuel filters to make sure they remain clean and free of debris.
- Talk to your selling dealer or local marina about fuel additives that help prevent fungus or other buildup in your gas fuel tank.

Fuel Filter/Water Separators (Diesel Engines Only)

NOTICE

- The frequency of water draining or element replacement is determined by the contamination level in the fuel.
- Inspect the collection bowls for water daily.
- Replace the elements at least once a year, or when a loss of power is noticed, whichever comes first.

- Each fuel feed line features a fuel filter/water separator.
- Service instructions for the fuel filter/water separators are provided on the filters.

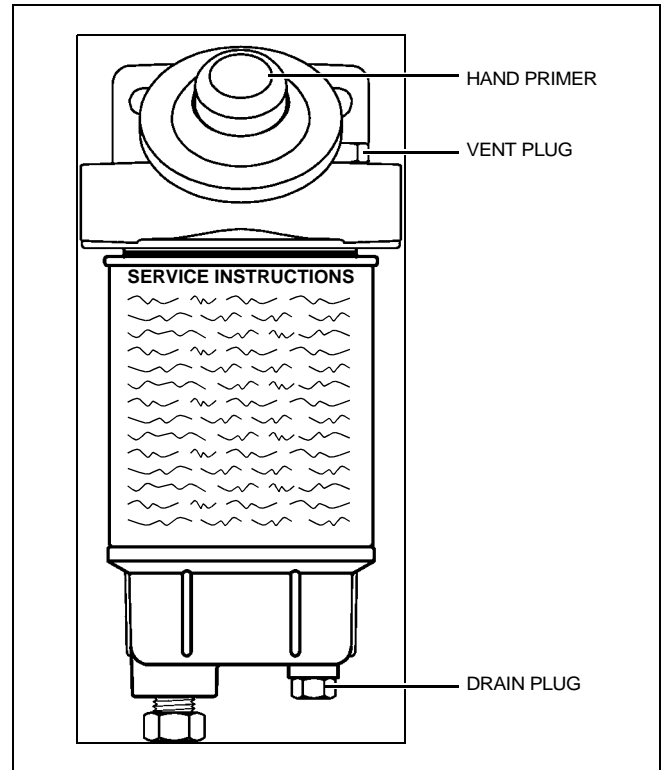

Anti-siphon Valves (Gas Engines Only)

NOTICE

- If an engine running problem is diagnosed as fuel starvation, check the anti-siphon valve.
- If the valve is stuck or clogged, change or replace it while the engine is *shut down*.
- **NEVER** run either engine with its anti-siphon valve removed, except in an emergency.

- The anti-siphon valves are vital fuel system parts.
- If a fuel line ruptures, this valve will prevent the fuel from siphoning from the tank.
- The valves are located on the fuel tank, where the fuel feed lines attach to the tank.
- These valves are spring loaded and are opened by fuel pump vacuum.

Fire Suppression System (If Equipped)

- The fire suppression system is designed to extinguish engine compartment fires.
- **Before** using your boat for the first time, read the fire suppression system's instruction and maintenance manual and follow **all** warnings.
- The system will discharge automatically whenever direct heat from a fire is detected in the engine compartment.
- The system can be discharged manually by pulling the T-handle (labeled "FIRE") at the helm.
- The system can **only** be discharged **once**.
- After the system is discharged it **must** be refilled and refurbished **before** it can be used again.

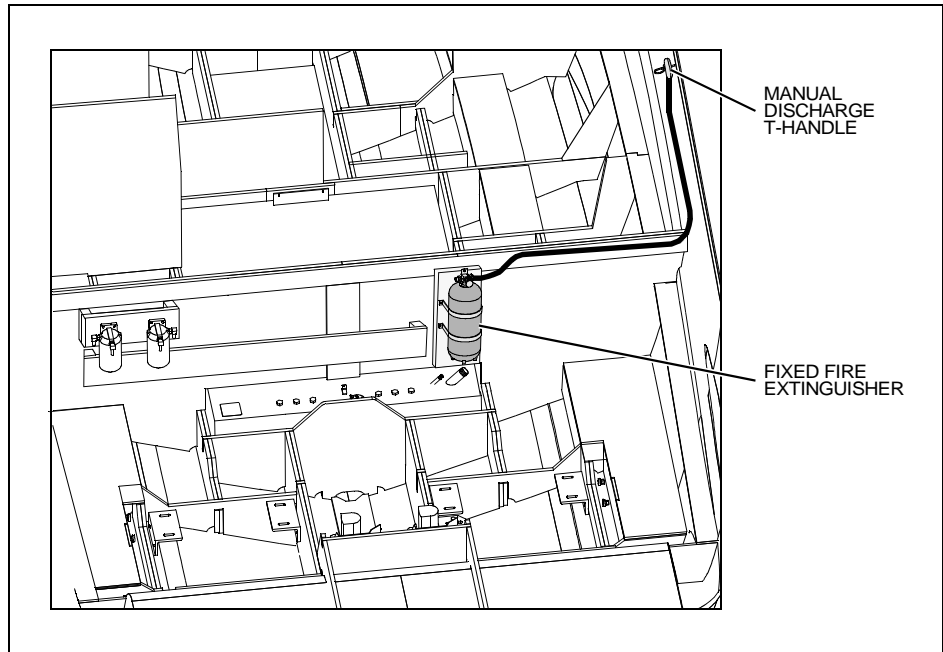

Quick Oil Drain System

- A quick oil drain assembly is attached to the oil pan on each engine.
- Some setup is needed *before* you can use this system.

Setting Up the Quick Oil Drain System

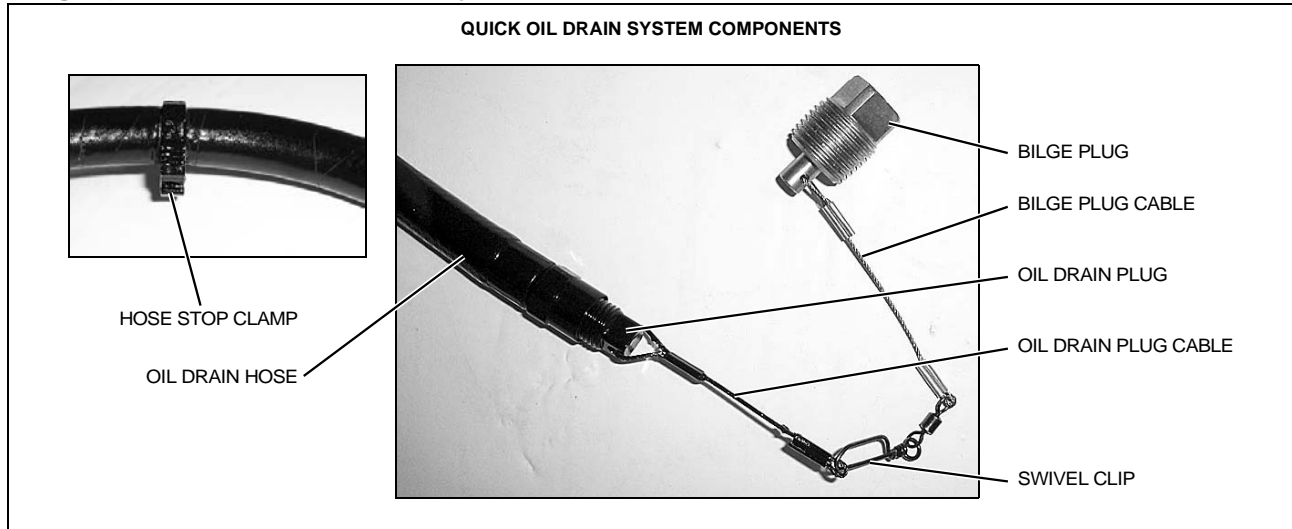

1. Unscrew the factory installed bilge plug from the bilge drain. **NOTE: Keep the factory bilge plug on the boat as a spare.**

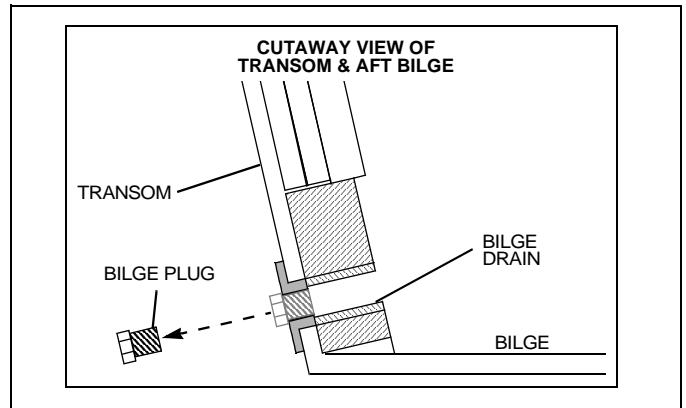

2. On the starboard engine, unclip the oil drain hose assembly and the bilge plug assembly from the wire loop.

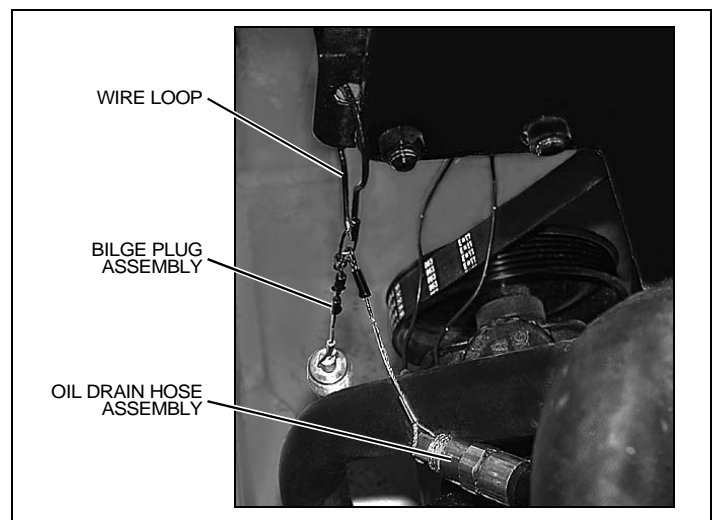

3. Unclip the bilge plug swivel clip from the cable on the end of the oil drain hose.
NOTE: This bilge plug assembly will be your spare. Keep it in the same location as the factory bilge plug removed in step 1.

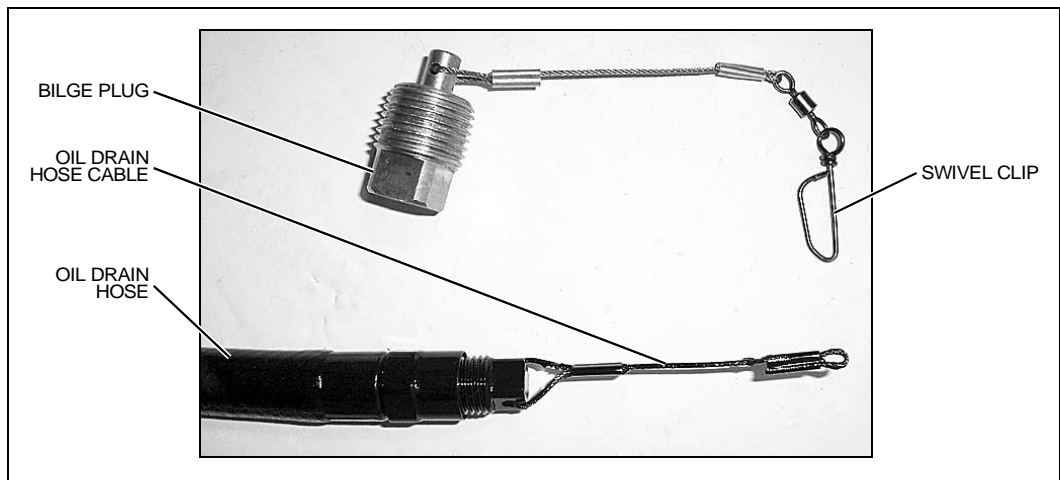

4. Feed the oil drain hose into the bilge area aft of the engine.

5. Thread the oil drain hose, cable, and plug out through the bilge drain.
 6. Adjust the hose stop clamp so that no more than 12 inches of hose, including the oil drain plug, can extend out of the bilge drain.

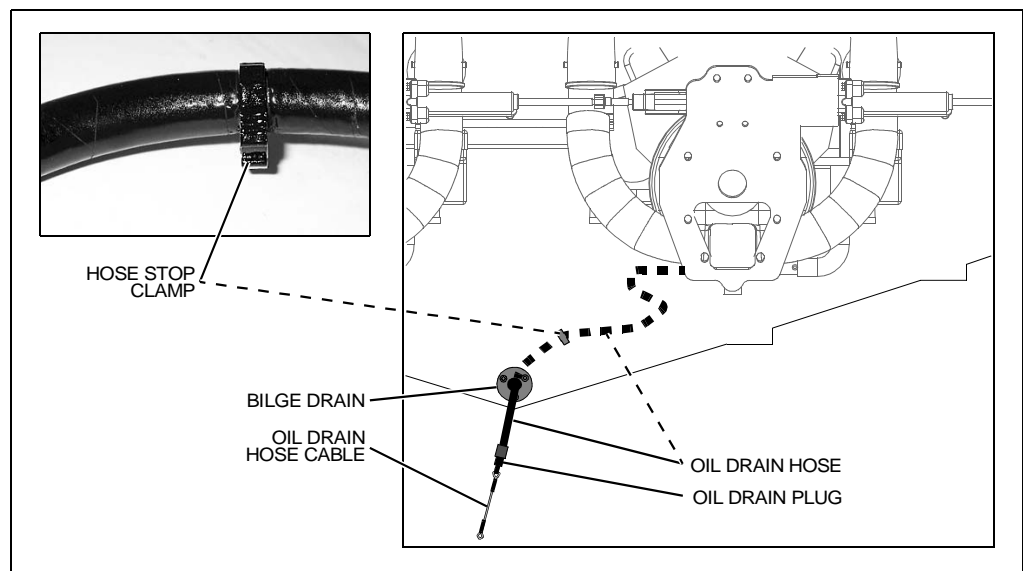

7. Push the oil drain hose and the oil drain plug back into the bilge, but leave the drain hose cable outside of the bilge drain.

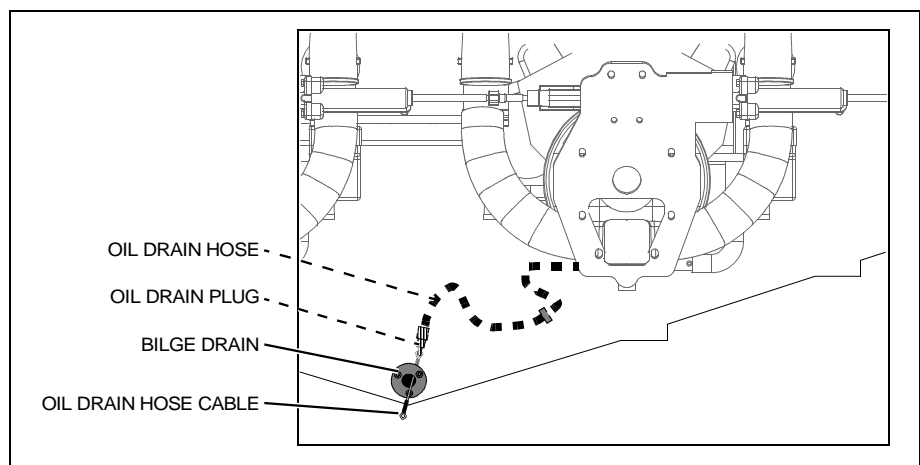

8. Repeat steps 2 through 7 on the port engine's quick oil drain assembly. The only difference being; **the bilge plug assembly, unclipped in step 3, will be used in step 9.**

- At this point, both of the oil drain hose cables should be hanging out of the bilge drain.

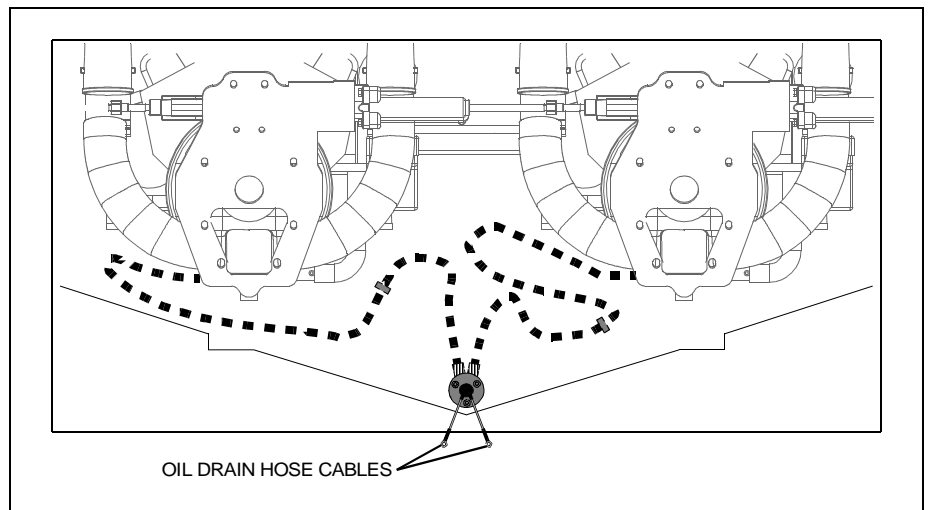

9. Clip the bilge plug swivel clip to both of the oil drain hose cables.
10. Push the oil drain hose cables and the bilge plug swivel clip and cable into the bilge.
11. Screw the bilge plug into the bilge drain and tighten firmly.

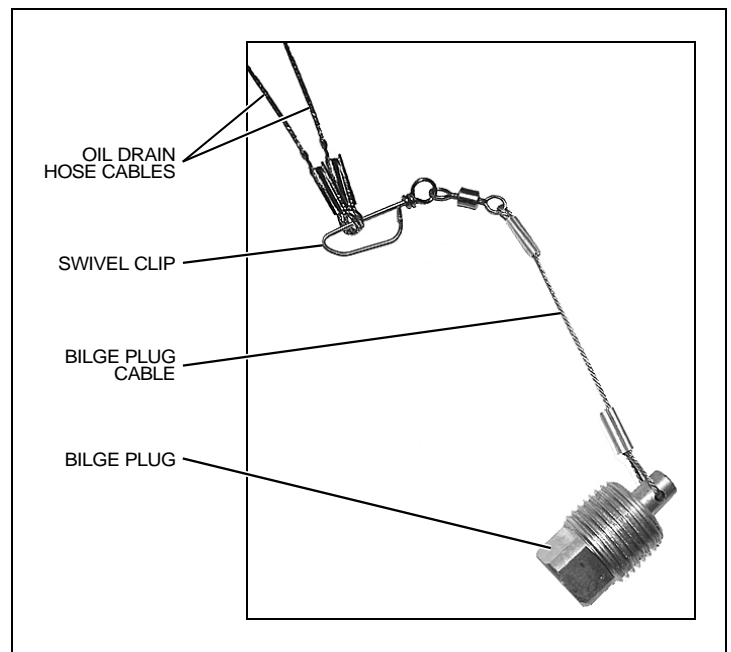

Using the Quick Oil Drain System

1. Remove the boat from the water.
2. Unscrew the bilge plug.
3. Pull the bilge plug cable out of the bilge drain until the swivel clip and the oil drain hose cables appear.
4. Unclip one of the oil drain hose cables from the swivel clip. **NOTE: Make sure the other drain cable remains attached to the swivel clip.**
5. Pull the unclipped hose cable until the oil drain plug and the oil drain hose slide out of the bilge drain.
6. Place the end of the oil drain hose into a suitable container.
7. Unscrew the oil drain plug and drain the engine oil.
8. Screw the oil drain plug back into the oil drain hose and tighten firmly.
9. Push the oil drain hose and oil drain plug back into the bilge.
10. Reclip the oil drain hose cable back onto the swivel clip.
11. Repeat steps 4 through 10 beginning with uncoupling the other oil drain hose cable.
12. Push all of the cables back into the bilge and screw the bilge plug into the bilge drain and tighten firmly.
13. Dispose of the waste oil in accordance with local regulations.

Chapter 4: Controls & Gauges

Steering

- This boat features a power assisted rack-and-pinion steering system.
- For information about the 'power assist fluid reservoir', refer to the engine operation and maintenance manual.
- Boat steering is *not* self-centering.
- Refer to the engine manual for more steering system details.

Shift/Throttle Controls

 WARNING!
<i>LOSS OF CONTROL HAZARD!</i>
Improper maintenance of the shift/throttle hardware may cause a sudden loss of control!

Read *all* of the information about the shift/throttle controls in the shift/throttle manual, the engine operation manual, and the *Cruiser & Yacht Owner's Manual*.

Power Trim & Tilt

- The stern drives on your boat are equipped with power trim and tilt.
- Trim and tilt instructions are provided in the engine operation manual and the shift/throttle manual.

Trim Tabs

WARNING!

LOSS OF CONTROL HAZARD!

Improper use of trim tabs *WILL* cause loss of control!

- Do **NOT** allow anyone unfamiliar with trim tabs to use them.
- Do **NOT** use trim tabs in a following sea as they **WILL** cause broaching or other unsafe handling characteristics.
- Do **NOT** use trim tabs to compensate for excessive unequal weight distribution.

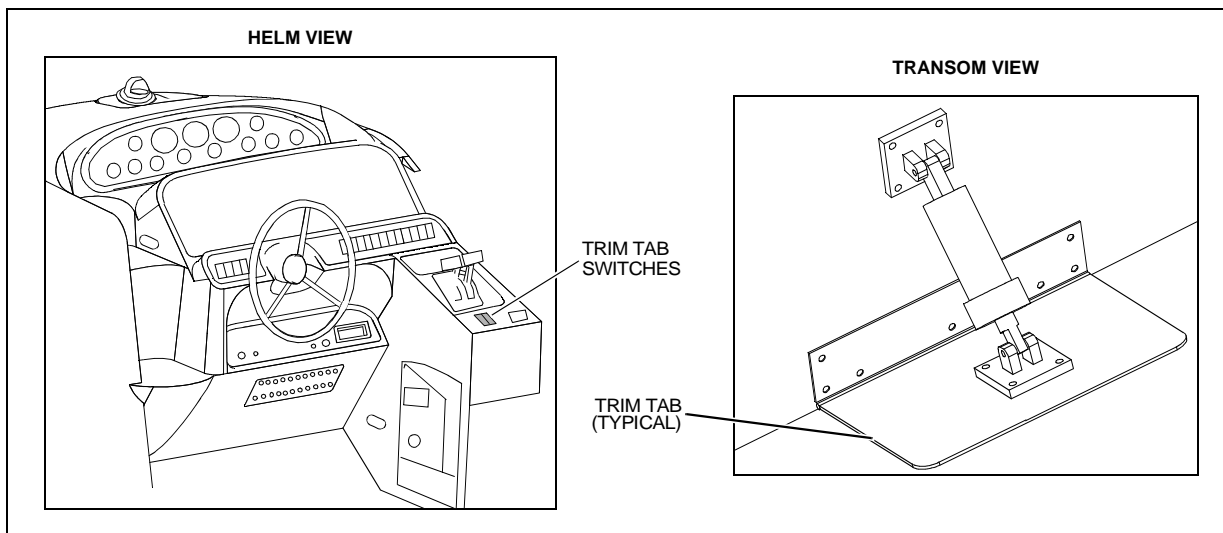

- **Before** using the trim tabs read the trim tab operation manual.
- The trim tabs can be used to help keep your boat level at cruising speeds.
- The trim tabs are controlled by two rocker switches at the helm.
- Once cruising speed is reached, the port or starboard trim switch may be used (one at a time) to level the boat.
- Perform trim tab adjustment with several short touches to the switch rather than one long one.
- After each short touch allow several seconds for the hull to react.
- Periodically (at least once a year) check the fluid level in the trim tab hydraulic fluid reservoir and refill as needed. For the location of the fluid reservoir, see the Component Locations section of Chapter 2 in this *Supplement*.

Gauges

Cleaning Gauges

 CAUTION
<i>PRODUCT or PROPERTY DAMAGE HAZARD!</i>
<ul style="list-style-type: none">• Use only mild soap and water to clean the gauge lenses and bezels.• Use of other cleaners, including common window cleaning solutions, may cause the lenses to crack.• Lenses cracked in this manner will NOT be covered by our warranty.

Gauge Fogging

- Moisture may occasionally find its way into the gauges causing lens fogging.
- Turning *On* the gauge lights will help dry the lenses.
- Fogging will not harm the gauges.

Radio Transmission Interference

VHF or other radio transmissions may cause brief erratic readings on the tachometer. This will not damage the tachometer gauge or affect its accuracy when not transmitting.

Fuel Gauge

It is normal for the pointer on your fuel gauge to bounce as fuel sloshes back and forth in the fuel tank.

Twin Engine Readings

It is normal for tachometers and other gauges to have slightly different readings between engines.

Chapter 5: Navigation & Communication Equipment

Read the manuals for *all* navigation & communication equipment *before* using these systems.

Compass

NOTICE

- **Compass accuracy can be affected by many factors.**
- **Have a qualified technician calibrate your compass.**
- **Make sure the technician gives you a deviation card which shows the corrections to apply in navigational calculations.**
- **Keep a copy of the deviation card at the helm.**

Depth Finder



WARNING!

- **Do *NOT* use the depth finder as a navigational aid to prevent collision, grounding, boat damage or personal injury.**
- **When the boat is moving, submerged objects will *NOT* be seen until they are already under the boat.**
- **Bottom depths may change too quickly to allow time for the boat to react.**
- **If you suspect shallow water or submerged objects, run the boat at very slow speeds.**

VHF Radio (If Equipped)

- Your boat may include a VHF (Very High Frequency) radio.
- The VHF radio can be used to access weather reports, summon assistance or contact other vessels as permitted by the FCC (Federal Communications Commission).
- Contact the FCC for licensing, rules and regulations concerning VHF radio usage.

Chapter 6: Plumbing

Bilge Pumps

NOTICE

Discharge of oil, oil waste, or fuel into navigable waters is prohibited by law. Violators are subject to legal action by the local authorities.

- Your boat is equipped with two bilge pumps for pumping water out of the bilge.
- The bilge pumps are controlled by automatic float switches (autofloat switches) and/or switches at the helm.
- The bilge pumps are wired directly to the battery.
- Unless the battery is dead, the pumps should work even when the boat is unattended.

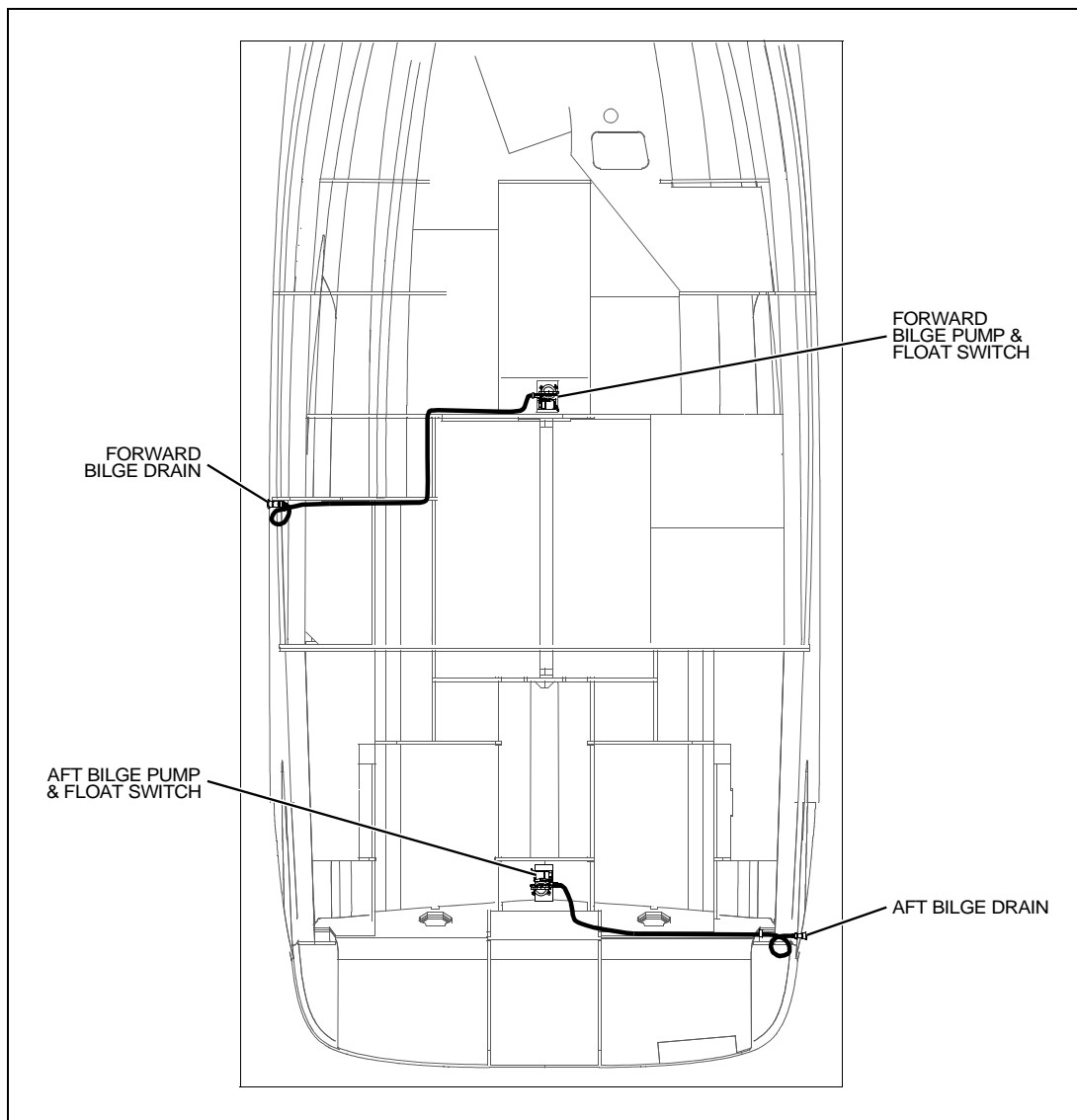

Bilge Pump Testing

- The bilge pumps are vital to the safety of your boat.
- Test the bilge pumps often to make sure they are working properly.

To test each bilge pump:

1. One at a time, turn *On* each bilge pump switch at the helm.
 2. Make sure that water in the bilge is pumped overboard.
- If there is water in the bilge and the pump motor is running but *not* pumping, inspect the discharge hose for a kink or collapsed area.
 - If the discharge hose looks okay, check the bilge pump housing for clogging debris.

Checking for clogging debris:

1. Remove the pump motor from the housing:
 - a. Lift the tab while rotating the fins counter-clockwise.
 - b. Lift out the pump motor.
 - c. Clear the housing of debris.
2. Reinstall the pump motor:
 - a. Make sure the "O" ring is properly seated.
 - b. Coat the "O" ring with a light film of vegetable or mineral oil.
 - c. Align the cams on either side of the pump motor with the slots on the housing.

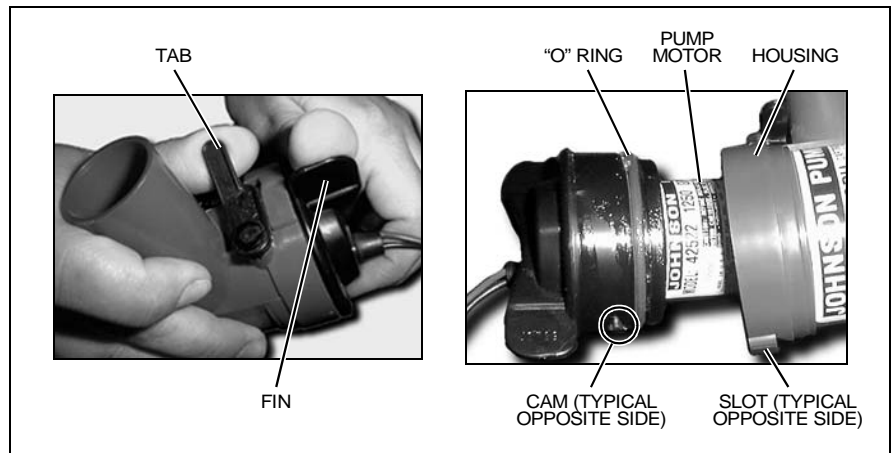

- d. Press the pump motor into the housing while twisting clockwise.
3. Check the reinstallation by trying to twist the fins counter-clockwise *without* lifting the tab; the pump motor should stay in place.

Autofloat Switches

- The automatic bilge pumps use float (autofloat) switches to automatically turn **On** the pumps whenever water rises to a preset level in the bilge.
- The autofloat switches are normally mounted next to the bilge pumps they control.
- The autofloat switches should be tested often.

Autofloat testing:

1. Lift the float switch test button **up** to turn **On** the bilge pump.
 - If the pump does **not** turn **On**, check the fuse on the fuse block.
 - If the fuse is good but the switch still doesn't work, it may mean the switch is bad or possibly the battery is low.
2. After testing, push the test button all the way **down** to return the float switch to auto mode.

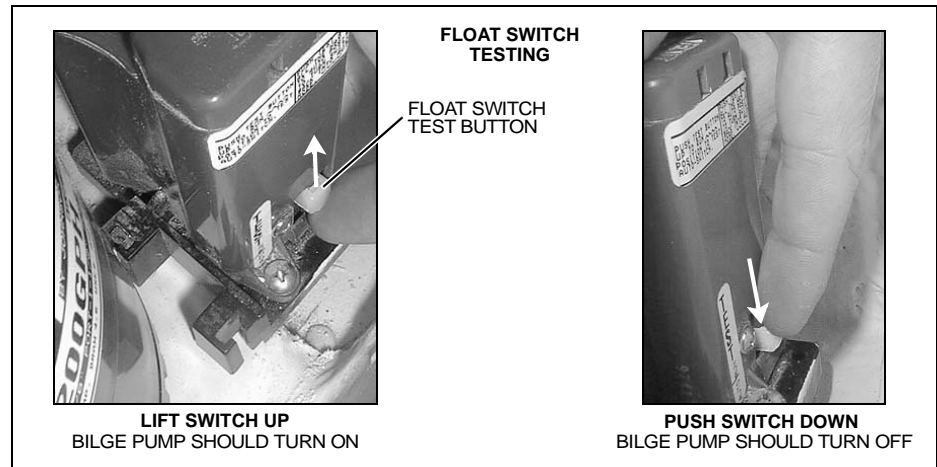

CAUTION

When the test is completed on each float switch, you **MUST** push the test button *all the way down* to return the switch to auto mode!

Seawater Systems

Seacocks

 **WARNING!**

FLOODING & SWAMPING HAZARD!

- *Close* the seacock(s) when leaving the boat unattended for any length of time.
- If a seacock is left open, a hose failure could flood the bilge, swamp the batteries and the engines, and even sink the boat.

 **CAUTION**

SYSTEM DAMAGE HAZARD!

- *BEFORE* using any system that has a seacock, make sure that the system's seacock is *Open*.
- Inspect and lubricate all seacocks annually.

Thru-hull inlet or outlet fittings near or below the waterline feature seacock valves. You can close a seacock to stop water entry:

- If the hose connected to the seacock fails, or;
- To work on equipment served by the seacock.

Seacocks are used on your boat in seawater intake or liquid discharge systems including, but not limited to:

- Air conditioner
- Marine head (toilet)

Before using any system with a seacock, make sure the seacock is *Open* and stays *Open* until the system is shut *Off*.

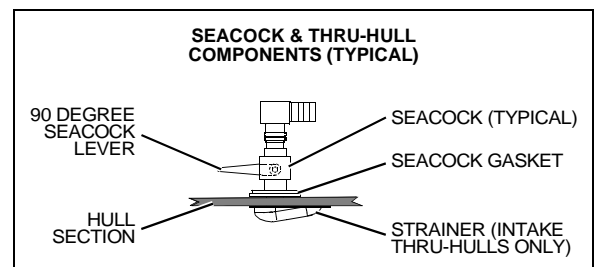

Seawater Strainers

 **CAUTION**

FLOODING HAZARD!

- *BEFORE* taking apart a seawater strainer for cleaning or other maintenance, *Close* the seacock that sends seawater to that strainer.
- Failure to close the seacock before taking apart the seawater strainer may allow large amounts of water to flood the bilge, which could swamp the batteries and the engines, and even sink the boat.
- Keep the seacock *Closed* until the seawater strainer is completely reassembled.

SYSTEM DAMAGE HAZARD!

- After putting the seawater strainer back together, make sure that the seacock valve is *Open* *BEFORE* using the component/system.

- Seawater strainers are used to filter incoming seawater in some seawater-intake systems.
- If equipped, the seawater strainer is located near the seawater-intake system's seacock.
- Check the strainers for leaks and/or debris *every time* you use your boat.
- Refer to the seawater strainer instruction sheet for cleaning and maintenance information.

Freshwater System



WARNING!

- **Only** use safe drinking (potable) water in your boat's freshwater system.
- **Only** use an FDA approved, white 'drinking water safe' hose to fill the freshwater tank.
- **NEVER** use a common garden hose for drinking water.

- Read the *Freshwater System* section in the *Cruiser & Yacht Owner's Manual*.
- Your boat is equipped with a pressure type (demand) freshwater (potable) system.
- Pressurize the system by turning **On** the freshwater pump switch.
- See the *Locations* section of this *Supplement* for the location of the freshwater pump switch.
- Since the freshwater pump requires DC power, the battery switch **must** also be turned **On** for the pump to work.
- Turn **Off** the freshwater pump switch when the boat is **not** in use or when the freshwater tank is empty.
- Inspect and clean the fresh-water filter often (located on the freshwater pump).
- If your boat is to be left unattended for a long period of time, pump the freshwater tank dry to prevent stored water from becoming stagnant and distasteful.
- If the freshwater system needs to be disinfected, ask your dealer about treatments available for your boat's system.

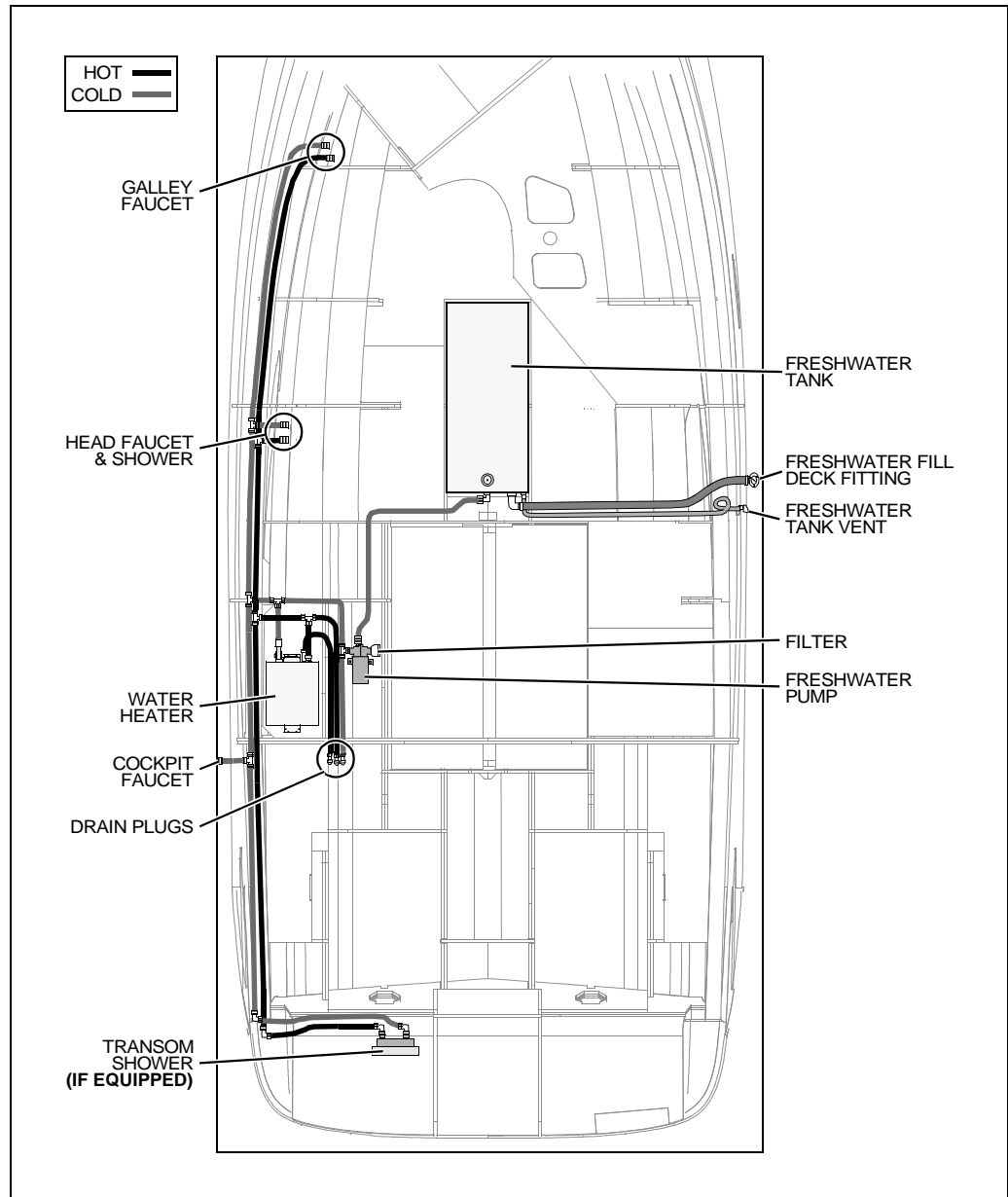

Transom Shower (If Equipped)

- Read the manufacturer's instructions before using the transom shower for the first time.
- The water pump switch **must** be turned **On** before using the transom shower.

Freshwater System Winterization



CAUTION

WATER SYSTEM DAMAGE HAZARD!

NEVER blow compressed air through the water system when *all* of the faucets are *Closed*.

1. Turn **Off** the water heater breaker switch.
NOTE: *Tag* or *Mark* the water heater breaker switch to prevent it from being turned **On** while the water heater tank is empty.
2. Turn **On** the freshwater pump switch.
3. **Open all** of the faucets and showers and let the water system drain completely.
4. Turn **Off** the freshwater pump switch.

All remaining water **must** be removed from the water lines. There are two ways to remove the remaining water from the lines:

- Compressed Air
- Gravity Draining

Compressed Air

You **must** have an air compressor with an air hose and an air nozzle.

1. Remove the drain plug from the cold water drain line.
2. **Open** the faucet that is furthest away from the freshwater pump.
3. Place the air nozzle against the end of the cold water drain line and blow air through the system.
4. When water stops coming out of the **Open** faucet, stop the air and **Close** the faucet.
5. One at a time, repeat this process on **all** faucets and showers.
6. When finished, put the drain plug back in.
7. Repeat the process on the hot water drain line.

Gravity Draining

1. **Open all** faucets and showers.
2. Remove the drain plug from the cold water drain line.
3. Drain any water in the drain line into the bilge or a bucket.
4. When the water has stopped draining from the drain line, put the drain plug back in.
5. Repeat the process on the hot water drain line.

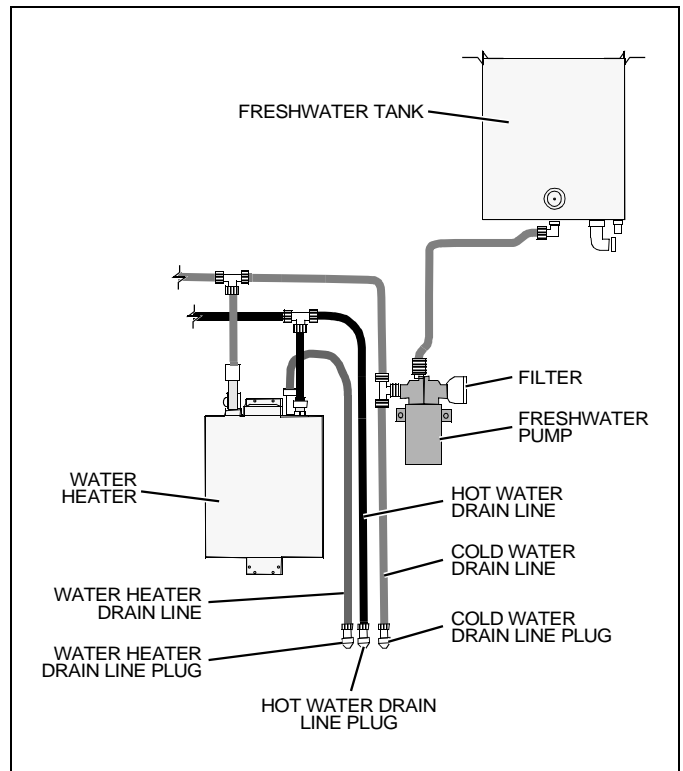

Water Heater

! WARNING!

! SCALDING HAZARD!
Water heated by the water heater can be hot enough to scald the skin.

! CAUTION

WATER HEATER DAMAGE HAZARD!

- Do **NOT** turn **On** the water heater electrical circuit on the 110-volt AC master panel until the water heater tank is **COMPLETELY** filled with water.
- The tank is full if water flows from the tap when the hot water is turned **On** in the galley.
- Even brief water heater operation with a dry tank **WILL** damage the heating elements.
- Warranty replacements will **NOT** be made on elements damaged in this manner.
- Drain the water heater and turn the power **Off** when the possibility of freezing exists (see winterizing instructions below).

NOTICE

If your boat is connected to shore power or generator power, but the water heater is not working:

- Make sure the water heater circuit breaker on the 110-volt AC master panel is switched **On**.
- If the circuit breaker is **On**, but the water heater is still not working, ask your dealer how to check the push-to-reset circuit breaker located on the water heater.

- Read the water heater instruction manual and heed the warnings above.
- The water heater is connected to the 110-volt AC power system.
- Turn **On** the water heater breaker on the 110-volt AC master panel to heat the water.

Winterizing the Water Heater

NOTICE

The freshwater system must be drained **BEFORE** winterizing the water heater (see Freshwater System Winterization Instructions on previous page).

1. Disconnect the hose (A) attached to the pressure relief valve (B).
 2. Drain any water in hose (A) into the bilge or a bucket.
 3. **Open** the pressure relief valve (B) and the drain valve (C).
 4. Remove the drain plug from the water heater drain line.
 5. When the water has stopped draining from the water heater drain line, replace the drain plug.
- Leave the pressure relief and drain valves **Open** until you fit out the boat after storage.

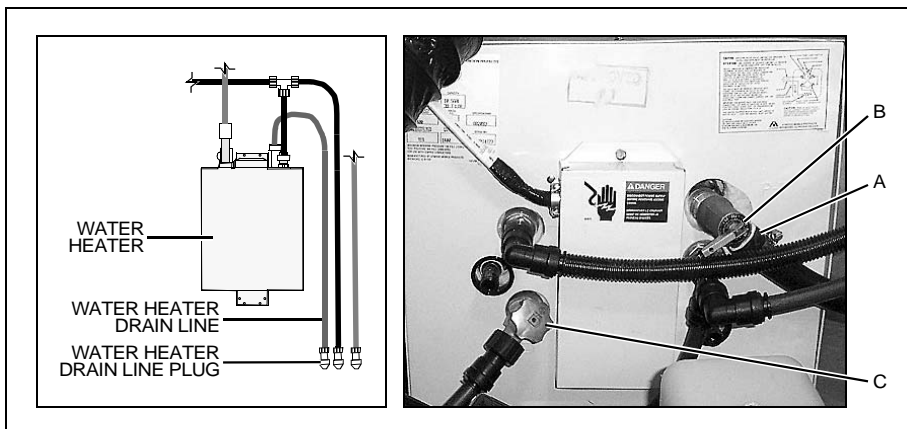

Drain Systems

Deck Drains

- Water on the deck is drained overboard through the deck drains.
- Keep the deck drains free of debris.

Gray Water Drains

The sinks are above the waterline and are gravity drained overboard.

Shower Drain Pump System

- Turn *On* the shower drain pump switch to pump the shower drain water overboard.
- See the *Locations* section of this *Supplement* for the locations of the shower drain pump switch and the shower drain pump.
- Periodically clean the strainer.

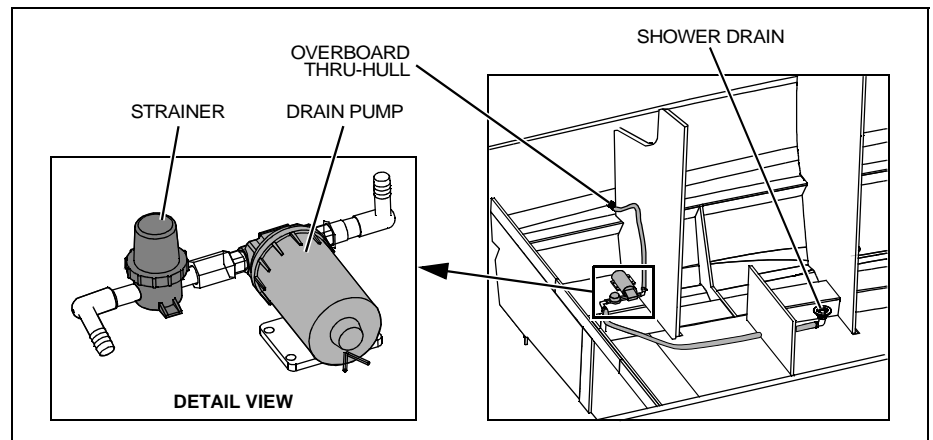

Marine Head with Holding Tank

NOTICE

Check with local authorities for regulations regarding the legal use of marine head systems.

- **Before** using this system, read the marine head operation and maintenance manual.
- Look at the side of the holding tank to check the content level.
- The holding tank is plumbed to a waste fitting on the deck for dock-side pump-out.
- Empty the holding tank at every opportunity.

Using the Marine Head

1. **Open** the head's seawater intake seacock.
 2. **Before** using the head, pump water into the bowl to wet the sides.
 3. After use, pump until the bowl is clean.
 4. Pump a few more times to clean the lines.
 5. If excess waste causes the water to rise in the bowl, stop pumping until the water recedes.
- **Close** the intake seacock when the system will not be used for long periods of time.

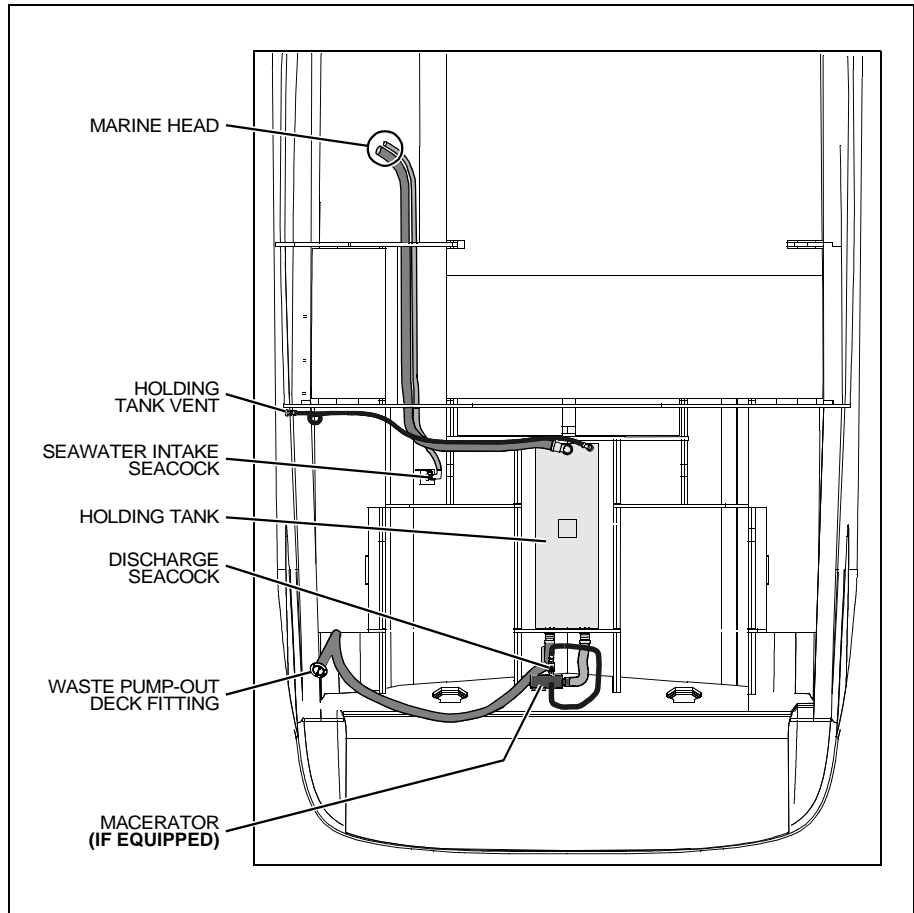

Winterizing the Marine Head

Read the marine head operation and maintenance manual for winterizing instructions.

Macerator (If Equipped)

NOTICE

Check with local authorities for regulations regarding the legal use of marine head systems.

To use the macerator to pump waste directly overboard (where regulations permit):

1. ***Open*** the discharge seacock.
2. Press both macerator switches at the same time to run the pump.
3. Stop running the macerator as soon as the waste holding tank is empty.
4. ***Close*** the discharge seacock when you are done pumping.

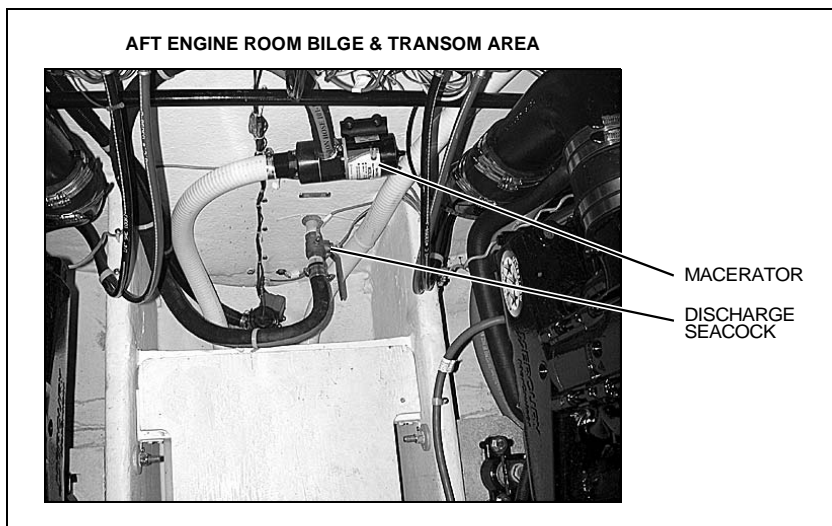

Chapter 7: Deck Equipment

Cleats & Tow Eyes

 WARNING!
<p>PERSONAL INJURY and/or PRODUCT or PROPERTY DAMAGE HAZARD!</p> <p>NEVER lift the boat using the bow and stern eyes or the cleats.</p>

Read the section on towing in the *Cruiser & Yacht Owner's Manual* **before**:

- Towing anything behind the boat.
- Being towed by another vessel.

Windlass (If Equipped)

 DANGER!
<p>PERSONAL SAFETY HAZARD!</p> <ul style="list-style-type: none"> • ALWAYS secure the anchor and other loose objects BEFORE getting underway. • The anchor and other items that are NOT properly secured can come loose when the boat is moving and cause personal injury or death.

 CAUTION
<p>PRODUCT DAMAGE HAZARD!</p> <p>Do NOT pull the boat to the anchor using the windlass or continue to run the windlass if it has stalled or is overloaded.</p>

- Read and follow the manufacturer's instruction manual **before** using the anchor windlass for the first time.
- The windlass can be controlled from a switch at the helm or from the deck foot switches.
- Make sure that the windlass breaker is turned **On before** using the anchor windlass.
- To raise the anchor, use engine power (**not** the windlass) to move the boat to, and directly above, the anchor.
- Dislodge the anchor from the bottom by pulling it straight up with the windlass.
- Make sure the anchor is secured **before** getting underway.

Canvas



CAUTION

PRODUCT or PROPERTY DAMAGE HAZARD!

Take down and securely stow **ALL** canvas **BEFORE** transporting your boat by road.

NOTICE

Two people are needed for most of the tasks listed in this section.

NOTICE

BEFORE cleaning and/or stowing your canvas or vinyl, read the sections later in this chapter, *Canvas Care* and *Vinyl Care*.

Bimini Top

- Slide the end eyes of the main bow (A) into the hinges (B) and insert the pins.
 - Slide the end eyes of the aft braces (C) into the hinges (D) and insert the pins.
 - Unfold the canvas (E) and slide the end eyes of the forward braces (F) into the hinges (G) and insert the pins.
 - Snap the aft edge (H) of the bimini top to the radar wing.
- The jaw slides (I) should **not** need to be adjusted.
 - If you decide to adjust the jaw slide positions, get the correct measurements from your selling dealer.

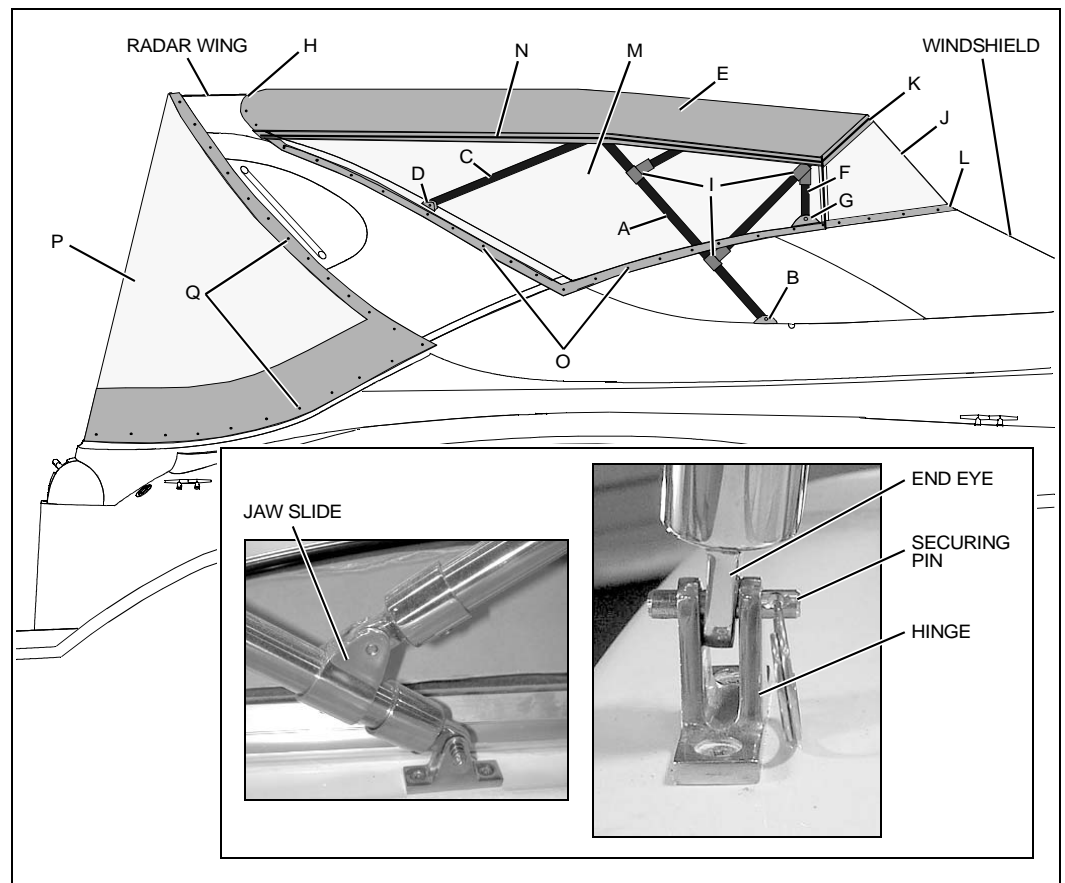

Camper Enclosure (If Equipped)

- Zip the forward vinyl curtain (J) to the forward zipper (K) on the bimini top.
- Snap the forward vinyl curtain to the forward windshield frame (L).
- Zip the side vinyl curtains (M) to the side zippers (N) on the bimini top.
- Snap the side vinyl curtains to the snaps (O) on the radar wing and side windshield frames.
- Complete the forward enclosure by zipping the side vinyl curtains to the forward vinyl curtain.
- Enclose the cockpit by snapping the aft vinyl curtain (P) to the snaps (Q) on the radar wing and aft deck.

Canvas Care (see also 'Clear Vinyl Care' on next page)

- After each use, especially in saltwater, rinse the canvas with cold freshwater.
- **Before** stowing, let the canvas air-dry completely.
- The canvas can be rolled or folded for stowage.

Cleaning Canvas

 CAUTION
<p>Never use detergents when washing the canvas. Detergents can destroy the water repellency and mildew/UV resistant finish of your canvas.</p>

Regularly clean the canvas to prevent dirt, pollen, and etc. from embedding in the fabric. Generally, it is easiest to wash the canvas while it is installed on the boat.

- Use a soft-bristled brush to remove all dust and loose dirt.
1. Hose down the canvas with freshwater.
 2. Gently wash the canvas with a solution of lukewarm water (no more than 100° F) and non-detergent soap, such as Lux or Ivory Flakes.
 3. Rinse thoroughly to remove the soap.
 4. **Before** stowing, let the canvas dry completely.

Stubborn Stains

 CAUTION
<ul style="list-style-type: none"> • Soaking in bleach solutions may remove the waterproof finish of the fabric and may also decrease the life of the polyester thread used in the canvas. • If necessary, a water repellent treatment should be reapplied to your canvas. Ask your dealer about the treatments available for your boat's canvas.

Some stubborn stains may resist normal washing and you can try the following methods. However, these methods may remove the waterproof finish of the fabric and may also decrease the life of the polyester thread used in the canvas. Reapply a water repellent treatment as necessary.

Method 1

1. Add 1/8 cup (2 oz.) of **non-chlorine** bleach to one gallon of water and mix thoroughly.
2. Thoroughly wet the canvas and then gently scrub the stained area with the weak bleach solution.
3. Rinse with cold water to remove all of the solution.

Method 2

1. Add 1/2 cup (4 oz.) of **non-chlorine** bleach and 1/2 cup (4 oz.) Ivory Flakes to one gallon of water and mix thoroughly.
2. Soak the canvas in this solution for about 20 minutes.
3. Rinse with cold water to remove all of the solution.

Clear Vinyl Care



CAUTION

- **NEVER** store the clear vinyl pieces wet, as this will cause a milky film to develop.
- **NEVER** fold or crease the clear vinyl pieces as cracking will occur.
- Clear vinyl is *not* intended for use when the boat is in storage or being moored.
- Clear vinyl *does not* hold up well against ultraviolet rays.
- Under direct sunlight conditions, do **NOT** let the clear vinyl touch the framework. The framework radiates heat and can burn the clear vinyl.

- After each use, especially in saltwater, rinse the clear vinyl with cold freshwater.
- **Before** stowing, the clear vinyl must be completely dry. Air drying is best, but you can also carefully dry the vinyl with a chamois or soft cotton cloth.
- The clear vinyl can be rolled or laid out flat for stowage.
- **Never** fold or crease the clear vinyl parts as cracking will occur.

Cleaning Clear Vinyl

Regularly clean the clear vinyl to prevent dirt, pollen, and etc. from marring the surface. Generally, it is easiest to clean the clear vinyl while it is installed on the boat.

1. Hose down the clear vinyl with freshwater.
2. Using a soft cotton cloth (**paper towels are abrasive and should never be used on clear vinyl**), gently wash the clear vinyl with soap and water.
3. Rinse thoroughly to remove the soap.
4. **Before** stowing, the clear vinyl must be completely dry. Air drying is best, but you can also carefully dry the vinyl with a chamois or soft cotton cloth.

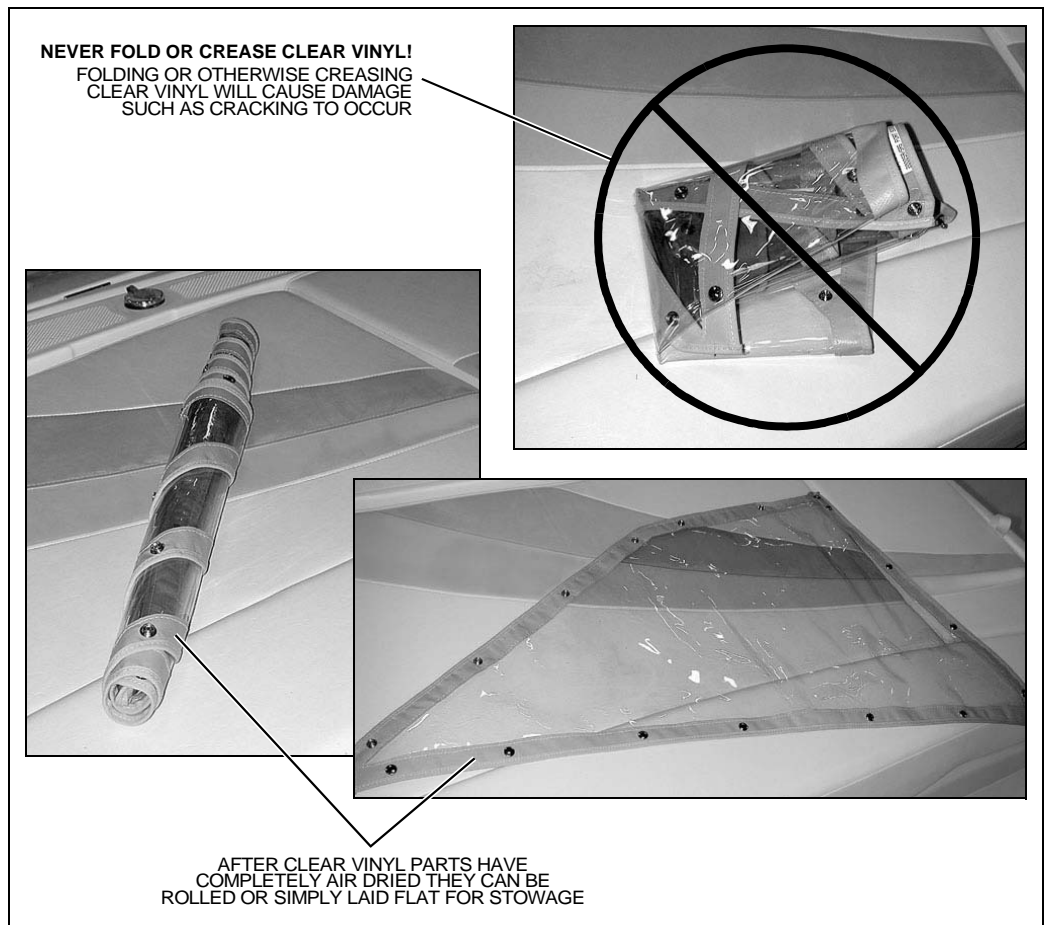

- Ask your dealer about products available to keep the clear vinyl polished and looking new.

Chapter 8: Appliances & Entertainment Systems

NOTICE

Always keep an approved ABC-type fire extinguisher in galley area.

- The separate instruction sheets or manuals for *all* appliances and entertainment systems contain detailed instructions and important safeguards.
- Read these instruction sheets and manuals *before* using your boat's appliances and entertainment systems.
- If applicable, make sure the 110-volt AC breaker is turned *On* for the appliance or entertainment system you wish to use.

Alcohol/Electric Stove

 **DANGER!**





CARBON MONOXIDE POISONING HAZARD!

- The alcohol stove is a source of dangerous carbon monoxide gas (CO).
- *BEFORE* using the alcohol stove, *Open* doors and windows to make sure there is enough fresh air for ventilation.

 **WARNING!**

- Open flame cooking appliances consume oxygen. This can cause asphyxiation or death.
- Maintain open ventilation.

 **WARNING!**



BURN/SCALDING and/or FIRE HAZARD!

- Read the stove's instruction manual *BEFORE* using.
- *ALWAYS* keep an approved ABC-type fire extinguisher in the galley area.
- Do *NOT* use the stove while underway.
- Any non-cooking devices on or near your stove during use are potential fire hazards!
- Do *NOT* touch the burners, grates or nearby surfaces as they may be hot even when they are dark in color.
- Areas near the burners and grates may become hot enough to cause burns.
- During and after use, do *NOT* touch or let clothing or other flammable material come in contact with the heated units or the areas near the units (burner tops, main frame sides and back, sea rails and pot holders) until they have had sufficient time to cool.

 **CAUTION**

PRODUCT DAMAGE HAZARD!

To prevent overheating which can destroy the electric burner elements, *NEVER* attempt to use both alcohol and electric burners at the same time.

Refrigerator

The refrigerator runs on 12-volt DC power unless 110-volt AC power is being supplied by shore power or generator power *and* the refrigerator's AC breaker is *On*.

Audio Equipment

NOTICE

AM radio reception may be impaired anytime the engine is running.

Chapter 9: Convertible Seats, Beds, & Tables

Dinette to Mid Berth Conversion

1. Remove the table (A) and the table leg (B).

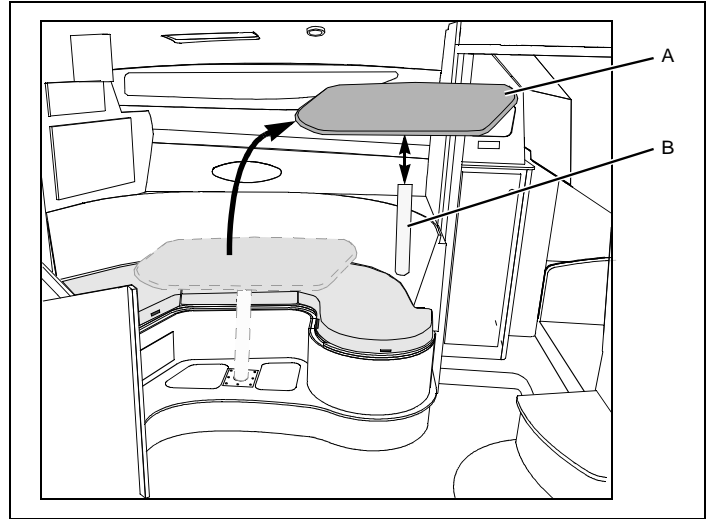

2. Place the filler board (C) so that it fits securely into the recessed edge (D) at the front of the dinette seats.

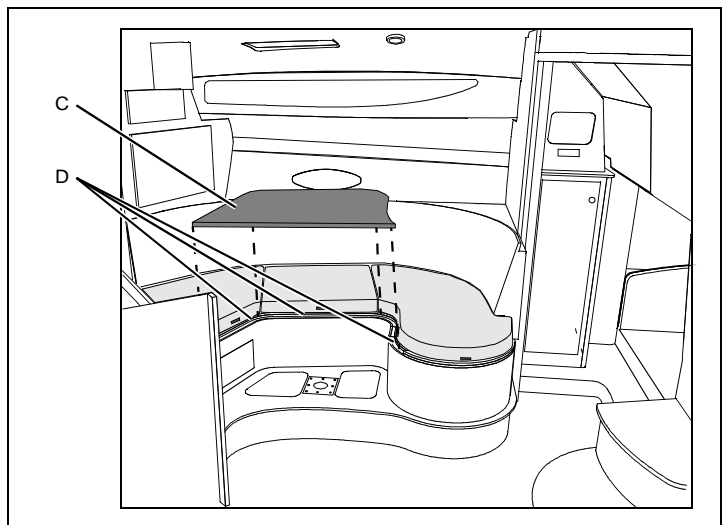

3. Place the filler cushion (E) on top of the filler board (C).

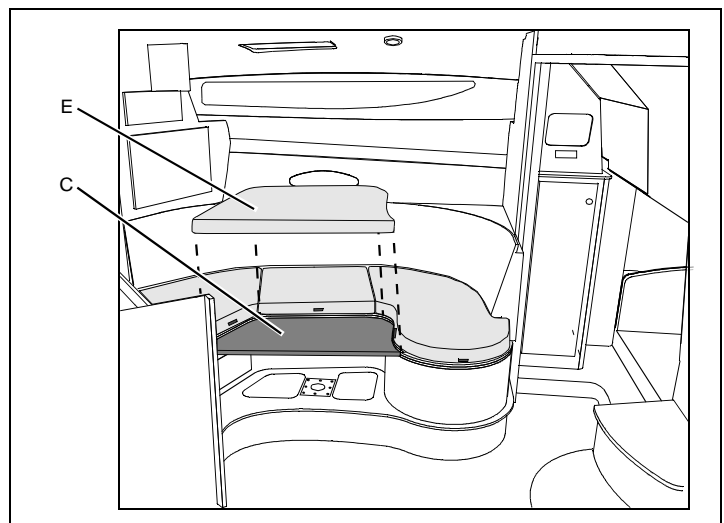

Cockpit Table to Sunlounge Conversion

1. Lift the table (A) and remove the table leg (B).

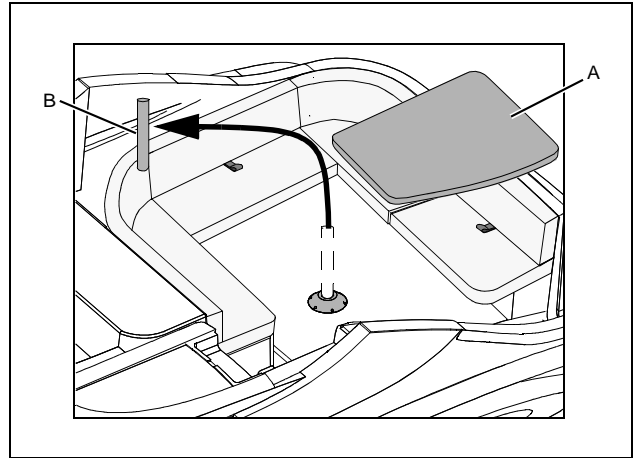

2. Put the cross supports (C) in place.
3. Place the table (A) on top of the supports (C).
4. Place the cushion (D) on top of the table (A).
5. Make sure *all* parts are secure *before* using the sunlounge.

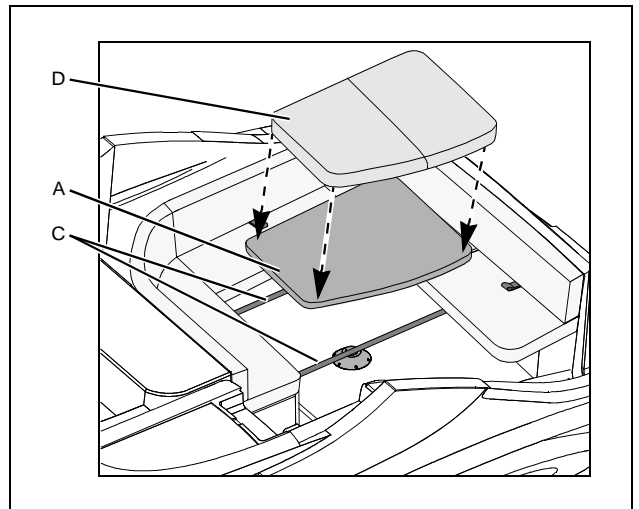

Chapter 10: Lights

Care & Maintenance

All of the lights installed on your boat are of top quality, but you should be aware that failure may periodically occur for a variety of reasons:

1. There may be a blown fuse - *replace the fuse.*
2. The bulb may be burned out - *carry spare bulbs for replacement.*
3. A wire may be damaged or may have come loose - *repair as required.*
4. The bulb base may be corroded - *clean the base and coat it with non-conductive electrical lubricant.*

Interior & Exterior Lights

 CAUTION
<ul style="list-style-type: none"> • Be conservative in the use of battery power. • Prolonged use of cabin interior lights (overnight) <i>WILL</i> result in a drained battery.

- The lights are powered by the boat's 12-volt DC system.
- The battery switch *must* be turned *On* for the lights to work.

Navigation Lights

 CAUTION
<p>Avoid the storage of gear where it would block navigation lights from view.</p>

NOTICE
<p>Running lights are legally required to indicate direction and right-of-way at night.</p>

Spotlight (If Equipped)

Read the spotlight operating instructions *before* using the spotlight.

Chapter 11: Heating & Air Conditioning

Air Conditioning System (If Equipped)

! **DANGER!**



CARBON MONOXIDE POISONING HAZARD!

Dangerous carbon monoxide gas (CO) can be brought into the boat through the air conditioning system.

! **CAUTION**

SYSTEM DAMAGE HAZARD!

The air conditioning system's seawater intake seacock ***MUST*** be *Opened BEFORE* turning *On* the air conditioner and ***MUST*** stay *Open* during use.

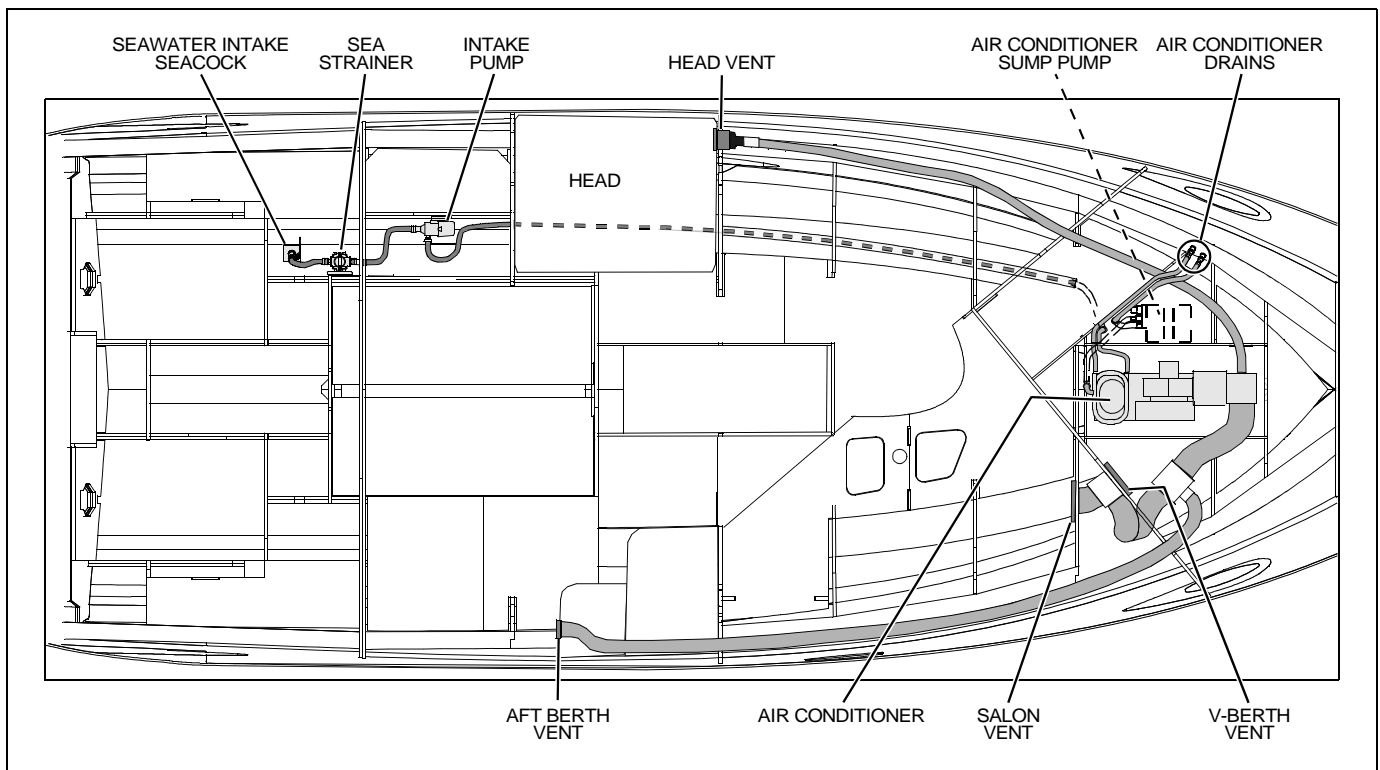

- Read the air conditioner manual *before* using the air conditioning system.
- ***Before*** using the air conditioning system, make sure the breakers on the 110-volt AC master panel are turned ***On*** and that the system's seawater intake seacock is ***Open***.
- The seacock ***must*** remain ***Open*** while the air conditioner is in use.
- Check the seawater strainer for debris ***before*** each use of the air conditioning system.
- If the strainer needs to be cleaned out, follow the directions in the *Seawater Systems* section of this *Supplement*.

Chapter 12: Electrical System

⚠ DANGER!









EXTREME FIRE, SHOCK & EXPLOSION HAZARD!

- To minimize the risks of fire and explosion, *NEVER* install knife switches or other arcing devices in the fuel compartment.
- *NEVER* substitute automotive parts for marine parts. Electrical, ignition and fuel system parts were designed and manufactured to comply with rules and regulations that minimize risks of fire and explosion.
- Do *NOT* modify the electrical systems or relevant drawings.
- Have qualified personnel install batteries and/or perform electrical system maintenance.
- Make sure that *all* battery switches are turned *Off BEFORE* performing any work in the engine spaces.

⚠ WARNING!

FIRE & EXPLOSION HAZARD!

- Fuel fumes are heavier than air and *WILL* collect in the bilge areas where they can be accidentally ignited.
- Visually and by smell (sniff test), check the engine and bilge areas for fumes or accumulation of fuel.
- *ALWAYS* run the bilge blowers for at least four minutes prior to engine starting, electrical system maintenance or activation of electrical devices.
- *NEVER* expose the batteries to open flame or sparks, and *NEVER* smoke anywhere near the batteries.

⚠ CAUTION



SHOCK & ELECTRICAL SYSTEM DAMAGE HAZARD!

When the engine is running, *NEVER* turn *Off* the battery switch or disconnect the battery cables. Doing either could cause damage to your boat's engine and/or electrical system.

NOTICE

Electrical connections are prone to corrosion. To reduce corrosion-caused electrical problems:

- Keep *ALL* electrical connections clean.
- Apply a spray-on protectant that is designed to protect connections from corrosion.

12-Volt DC System

Batteries

The batteries supply electricity for lights, 12-volt accessories, and engine and generator starting.

The Electrical section of Chapter 8, in the *Cruiser & Yacht Owner's Manual*, provides battery care and maintenance instructions.

Battery Switches

⚠ CAUTION

⚡ SHOCK & ELECTRICAL SYSTEM DAMAGE HAZARD!

When the engines are running, **NEVER** turn *Off* the battery switch or disconnect the battery cables. Doing either could cause damage to your boat's engines and/or electrical system components.

NOTICE

Make sure your selling dealer fully explains how to use the battery switches.

- Each battery switch has four (4) positions.
- The normal settings are:
Engine battery switch - position "2".
House battery switch - position "1".
- Some "Standby Loads", such as the automatic bilge pumps, and the stereo memory, are **not** affected by the battery switches since they are wired directly to the battery (see the *Wiring Diagrams* in this *Supplement* for more details).
- Turn the battery switches to the **Off** position whenever the boat will be unoccupied for long periods of time.

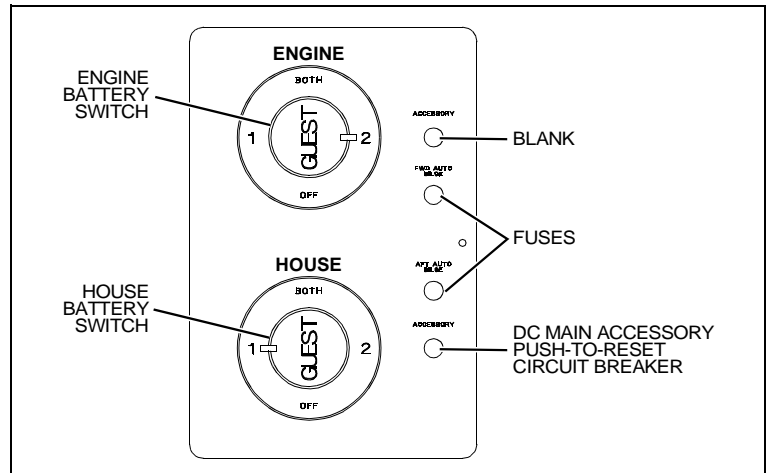

Battery Switch Positions

NOTICE
 Since your boat's batteries were installed by your dealer, the battery switch positions listed below may vary. Make sure your selling dealer fully explains how to use the battery switches.

BATTERY SWITCH	POSITION "1"	POSITION "2"	POSITION "BOTH"	POSITION "OFF"
ENGINE BATTERY SWITCH	<u>Battery Bank 1</u> provides port engine & generator (if equipped) starting power & alternator charging	<u>Battery Bank 2</u> provides port engine & generator (if equipped) starting power & alternator charging	<u>Connects Battery Banks 1 & 2</u> provides port engine & generator (if equipped) starting power & alternator charging	Prevents port engine & generator (if equipped) start/run
HOUSE BATTERY SWITCH	<u>Battery Bank 1</u> provides starboard engine starting power, alternator charging & power for accessories & lights	<u>Battery Bank 2</u> provides starboard engine starting power, alternator charging & power for accessories & lights	<u>Connects Battery Banks 1 & 2</u> provides starboard engine starting power, alternator charging & power for accessories & lights	Prevents starboard engine start/run

Fuses & Circuit Breakers

- Circuit breakers for engines and main accessory power are on the DC push-to-reset circuit breaker panel and on the battery switch panel.
- Some equipment may have secondary fuse protection at the unit, behind the battery switch panel, or at the batteries.
- See the *Locations* section of this *Supplement* for the locations of the battery switch panel and DC push-to-reset circuit breakers.

12-Volt Accessory Outlet(s)

 **CAUTION**
 Do *NOT* use the 12-volt accessory outlet with a cigarette or cigar lighter. High temperatures may melt the outlet.

- Your boat is equipped with one or more 12-volt accessory outlets.
- The outlet(s) can be used with any 12-volt device which draws 15-amps or less.
- Each 12-volt accessory outlet is protected by a 15-amp fuse on the DC push-to-reset circuit breaker panel.

Alternators

The alternators will keep the batteries properly charged when the engines are running at, or above, cruising speeds.

Battery Charger (If Equipped)

	<h3>CAUTION</h3>
<p>ENGINE & ELECTRICAL SYSTEM DAMAGE HAZARD!</p> <p>NEVER run the boat's engines and the battery charger at the same time.</p>	

	<h3>CAUTION</h3>
<ul style="list-style-type: none"> • The battery charging systems (alternator and battery charger) installed on your boat are designed to charge conventional lead-acid batteries. • BEFORE installing gel-cell or other new technology batteries, consult with the battery manufacturer about charging system requirements. 	

- **Before** using the battery charger, read **all** instructions and warnings: (1) on the battery charger, (2) on the batteries, and (3) in the battery charger manual.
- The battery charger will automatically charge your boat's batteries when 110-volt AC power is being provided by shore power or generator power (if equipped), **and** the battery charger circuit breaker on the 110-volt AC master panel is **On**.
- The battery switch can be in any position during charging.
- During battery charging you may use 12-volt accessories, such as the lights and stereo, but battery charging will take longer.

110-Volt AC System



CAUTION

WATER HEATER DAMAGE HAZARD!

- Do **NOT** turn *On* the water heater circuit breaker on the 110-volt AC master panel until the water heater tank is **COMPLETELY** filled with water.
- The tank is full if water flows from the tap when the hot water is turned *On* in the galley.
- Even brief water heater operation with a dry tank **WILL** damage the heating elements.
- Warranty replacements will **NOT** be made on elements damaged in this manner.

NOTICE

- Whether using shore power or generator power, using several 110-volt AC accessories at the same time can result in an overloaded circuit.
- You may have to turn *Off* one or more accessories to use another accessory.

NOTICE

The 110-volt AC system's design prevents the use of shore power and generator power at the same time.

- To gain a basic understanding of your boat's 110-volt AC system, read the handbook, "A Boater's Guide To AC Electrical Systems." If this handbook is not in your owner's packet, call 360-435-8957 and the handbook will be mailed to you.
- The 110-volt AC system can be energized by shore power or generator power (if equipped).
- Individual breakers on the 110-volt AC master panel **must** be turned *On* to supply power to the accessories you wish to use.
- The 110-volt AC master panel may contain circuit breakers for accessories that are **not** available for your boat.

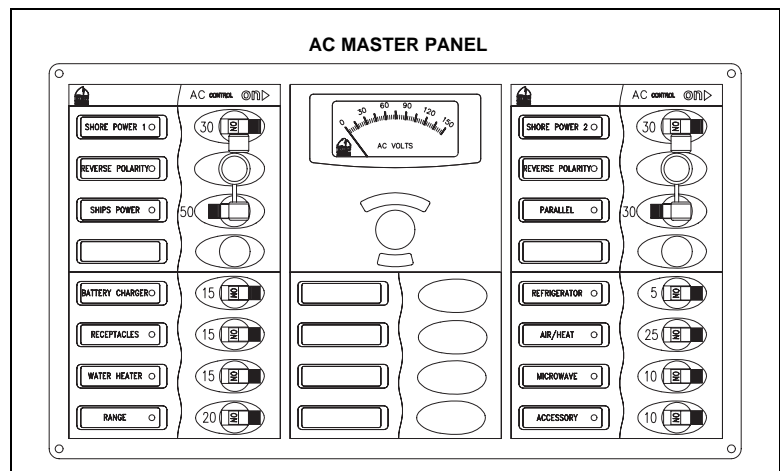



Shore Power

DANGER!



FIRE, EXPLOSION & SHOCK HAZARD!

- Do **NOT** alter the shore power connectors and use **ONLY** compatible connectors.
- Turn **Off ALL** breakers and switches on the 110-volt AC master panel **BEFORE** plugging in or unplugging the shore power cord.
- To prevent shock or injury from dropping a 'hot' cord into the water; **ALWAYS** plug the shore power cord into the boat inlet first; and then into the dockside outlet. When unplugging from shore power, **ALWAYS** unplug the shore power cord from the dockside outlet first.
- **NEVER** leave the shore power cord **ONLY** plugged into the dockside outlet.
- **ONLY** use shore power cords approved for marine use. **NEVER** use ordinary indoor or outdoor extension cords.

WARNING!



SHOCK & ELECTRICAL SYSTEM DAMAGE HAZARD!

- Monitor the polarity indicator lights **EVERY TIME** you connect to shore power.
- If a reversed polarity light turns **On** when you are connecting to shore power, do **NOT** turn **On** the main breaker switches.
- Instead, **IMMEDIATELY** unplug the shore power cord (**ALWAYS** from the dockside outlet first) and alert marina management.

WARNING!

SHOCK & ELECTRICAL SYSTEM DAMAGE HAZARD!

- **BEFORE** each use, check the shore power cord for defects or damage.
- **NEVER** use a damaged or faulty cord since the danger of fire and electrical shock exists.
- Do **NOT** pinch the shore power cord in doors or hatches, or coil the shore power cord too tightly, since these situations can generate enough heat to result in a fire.
- If a shore power cord is dropped into the water, **COMPLETELY** dry the blades and contact slots **BEFORE** using.

CAUTION

ELECTRICAL SYSTEM DAMAGE HAZARD!

- **NEVER** connect to dockside power outside of North America unless you have the international electrical conversion option.
- Using several 110-volt AC accessories at the same time can result in an overloaded circuit. You may have to turn **Off** one or more accessories to use another accessory.
- Use double insulated or three-wire protected electrical appliances whenever possible.

- The single shore power 110-volt/60-hertz AC system features one 110-volt/30-amp shore power receptacle.
- If your boat has an air conditioning system, a second (dual) 110-volt/30-amp inlet has been installed.
- Dual shore power inlets are labeled “LINE 1” and “LINE 2”, which corresponds to the “SHORE POWER 1” and “SHORE POWER 2” master breakers on the 110-volt AC master panel.
- LINE 1 and LINE 2 are independent of each other except when using the parallel switch.

Connecting to Shore Power

WARNING!

SHOCK & ELECTRICAL SYSTEM DAMAGE HAZARD!

- Monitor the polarity indicator lights *every time* you connect to shore power.
- If a reversed polarity light turns *On* when you are connecting to shore power, do *NOT* turn *On* the main breaker switches.
- Instead, *immediately* unplug the shore power cord (*always* from the dockside outlet first) and alert marina management.

1. Review *all* hazard information at the beginning of this section, *Shore Power*.
2. Turn *Off* the shore power master circuit breaker(s) and *all* switches and breakers on the 110-volt AC master panel.
3. Attach the shore power cord(s) to the boat inlet(s) first, then to the dockside outlet(s).
4. Turn *On* the "SHORE POWER 1" and "SHORE POWER 2" (if equipped) master breaker(s) on the 110-volt AC master panel.
5. On the 110-volt AC master panel turn *On* the individual component breakers as needed.

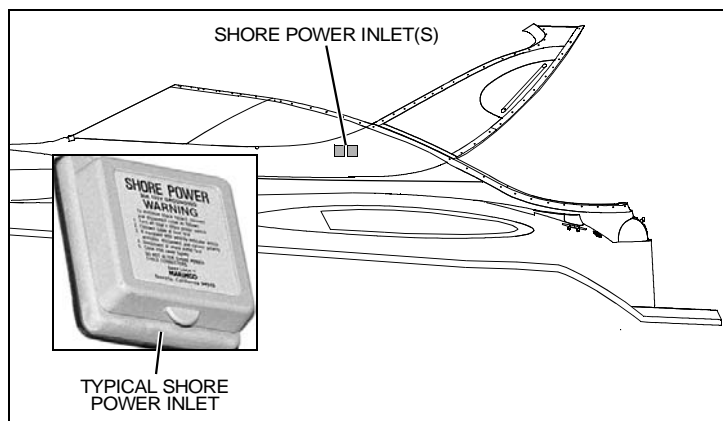

Parallel Switch (If Equipped with Dual Shore Power)



NOTICE



- When using the parallel switch do *NOT* exceed 30 total amps.
- The amperage of each component breaker is shown on the breaker itself.
- The voltage on each line can be read on the voltmeter on the 110-volt AC master panel.

When only one dockside outlet is available, you can use the Parallel Switch to provide power to both lines.

1. Connect to shore power as described in the section “Connecting to Shore Power” earlier in this chapter.
2. Switch the Parallel Switch *On* instead of the “SHORE POWER 2” master breaker.
3. Turn *On* the individual component breakers as required.

Generator (If Equipped)

 DANGER!	
	<p>CARBON MONOXIDE POISONING HAZARD!</p> <p>Generators are a source of dangerous carbon monoxide gas (CO). Check the generator exhaust system for leaks <i>BEFORE</i> each use.</p>

 WARNING!	
	<p>FIRE/EXPLOSION HAZARD!</p> <ul style="list-style-type: none"> • Use the bilge blowers for a minimum of four minutes <i>BEFORE</i> starting the generator. • Leave the blowers <i>On</i> while the generator is running. • Use of the blower system is <i>NOT a guarantee</i> that explosive fumes have been removed. <i>ALWAYS</i> use the 'sniff test' to check the bilge areas for fuel vapors. • If you smell any fuel, do <i>NOT</i> start the generator. • If the generator is already running, <i>IMMEDIATELY</i> shut <i>Off</i> the generator and <i>ALL</i> electrical accessories and investigate. • Do <i>NOT</i> obstruct or modify the ventilation system.

 CAUTION	
<p>SYSTEM DAMAGE HAZARD!</p> <ul style="list-style-type: none"> • <i>Always</i> make sure the generator's seawater intake seacock is <i>Open BEFORE</i> starting, and during running of the generator. • <i>NEVER</i> run the generator starter for more than 30 seconds. If the generator does not start, wait at least 30 seconds <i>BEFORE</i> trying again. • After the generator starts, let the generator stabilize <i>BEFORE</i> turning <i>On</i> the component breakers on the 110-volt AC master panel. 	

- When your boat is *not* connected to shore power, the generator can supply 110-volt/60-hertz power.
- *Before* using the generator, read the generator operation manual for pre-start checks and break-in procedures.
- Refer to the generator manual for starting/stopping instructions.

Note the following about the generator:

- Polarity has been established in the installation of the generator, therefore the polarity lights will *not* function in this mode.
- Periodically replace the fuel filter on the generator to make sure it remains clean and free of debris.
- Diesel generators also have a fuel filter/water separator. Service instructions are provided on the fuel filter/water separator.
- The coolant mixture installed at the factory consists of equal parts of water and antifreeze (Ethylene Glycol).
- Check the generator's seawater strainer for leaks and/or debris *before* each use.

Electrical Routings

110-Volt AC Hull Harnesses

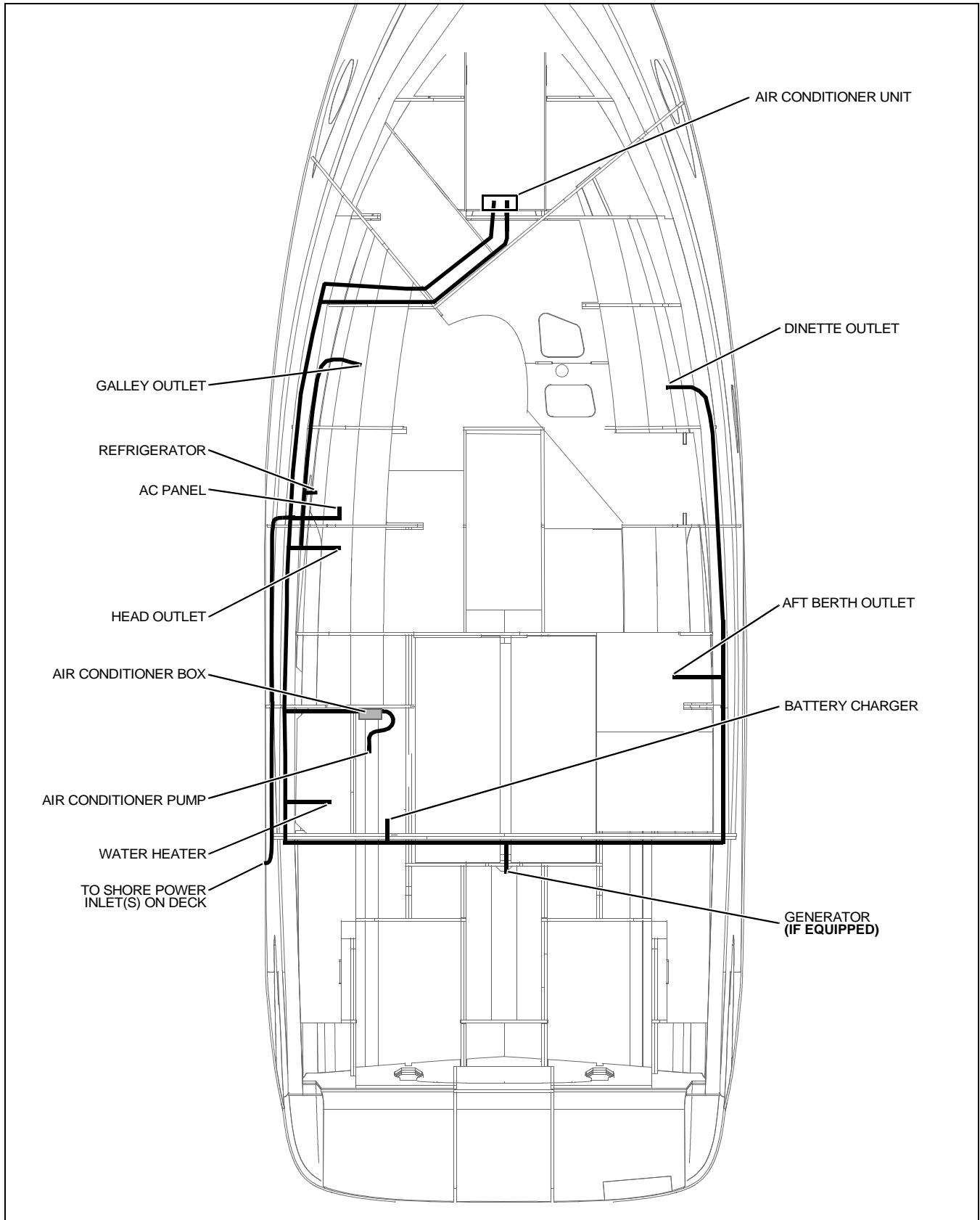

12-Volt DC Hull Harnesses

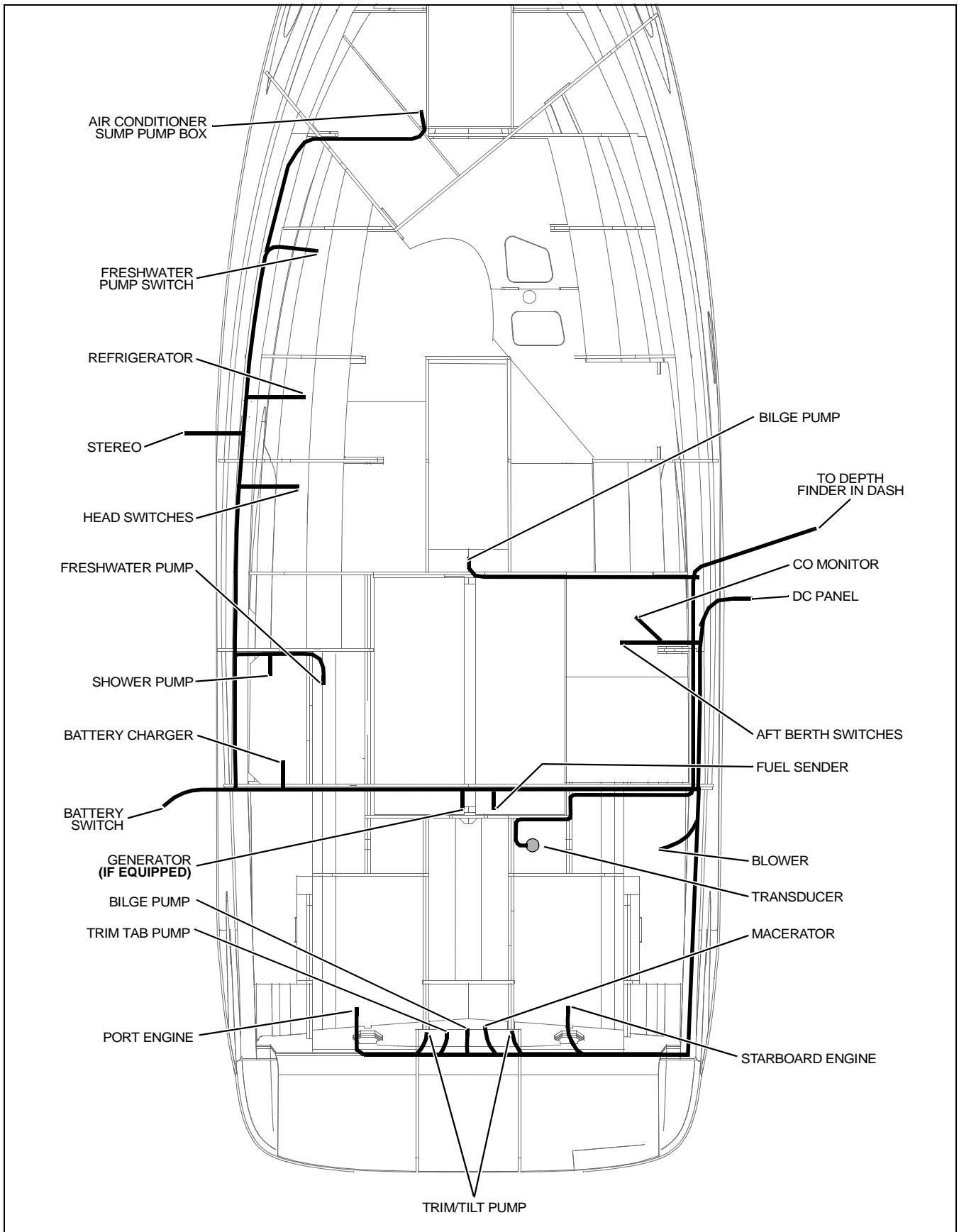

12-Volt DC Deck Harnesses

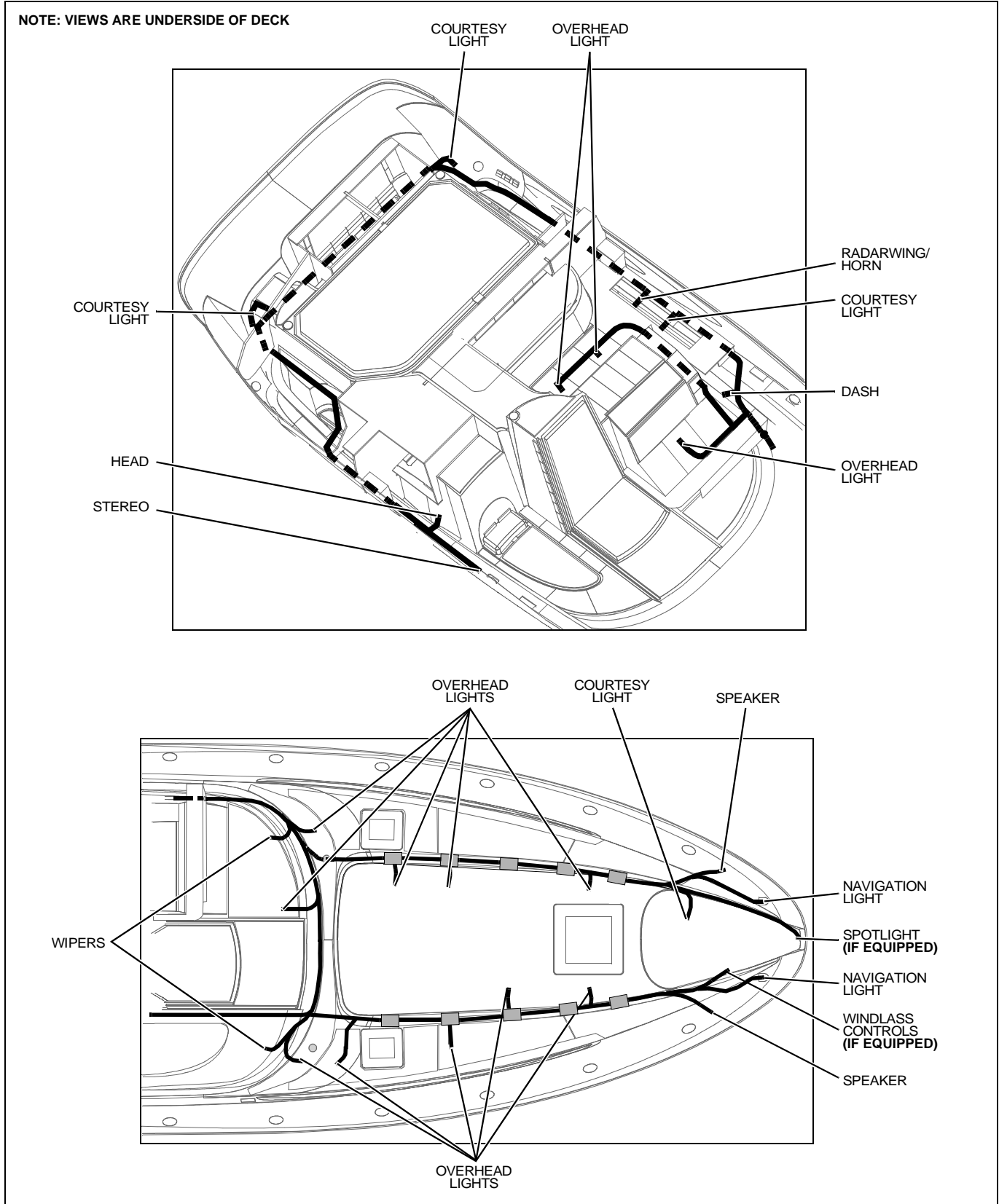

Radars Wing Harness

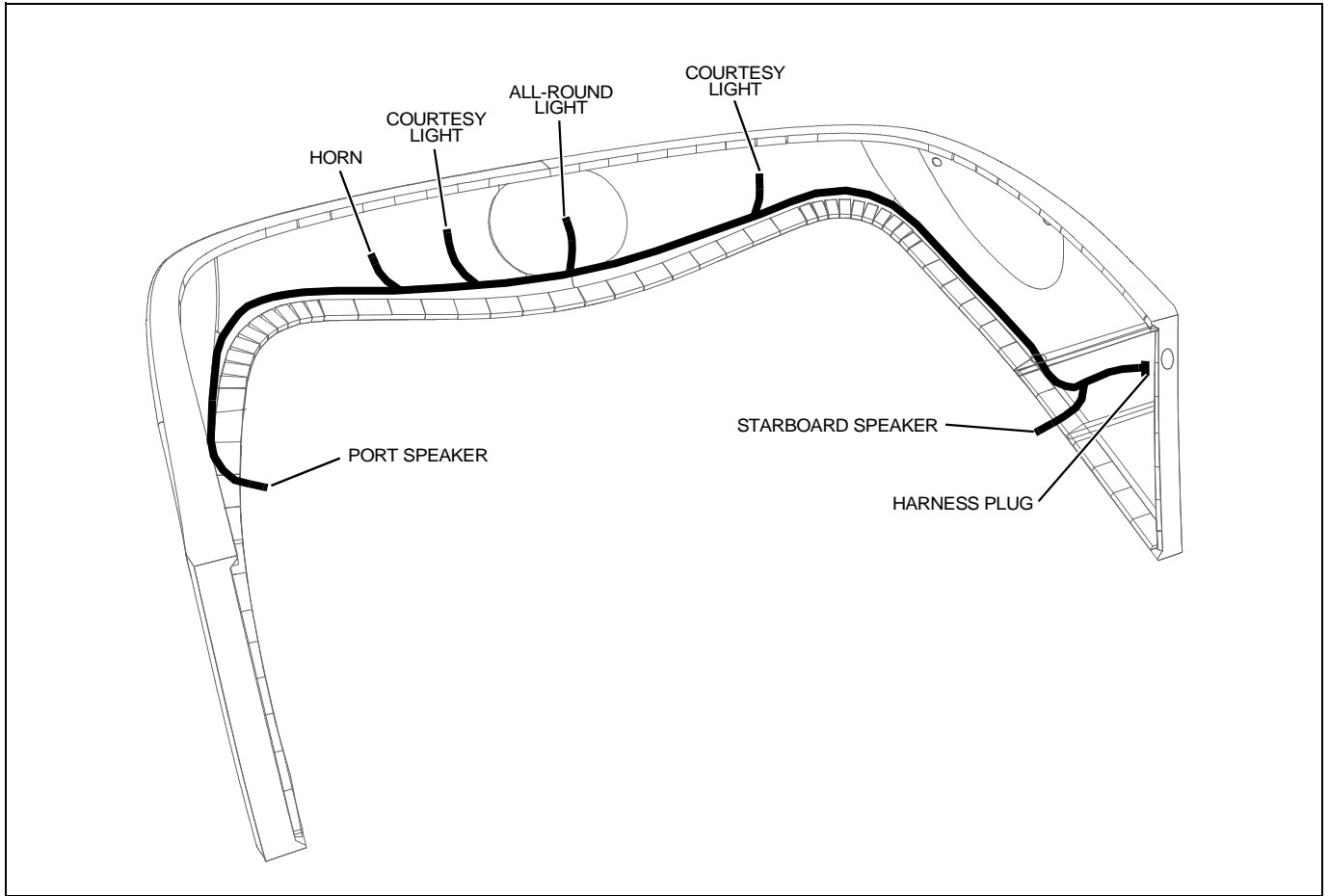

Gas Engines Battery Cable System

NOTES:
POSITIVE BATTERY CABLES ARE RED
NEGATIVE BATTERY CABLES ARE YELLOW

POSITIVE BATTERY CABLE ROUTING

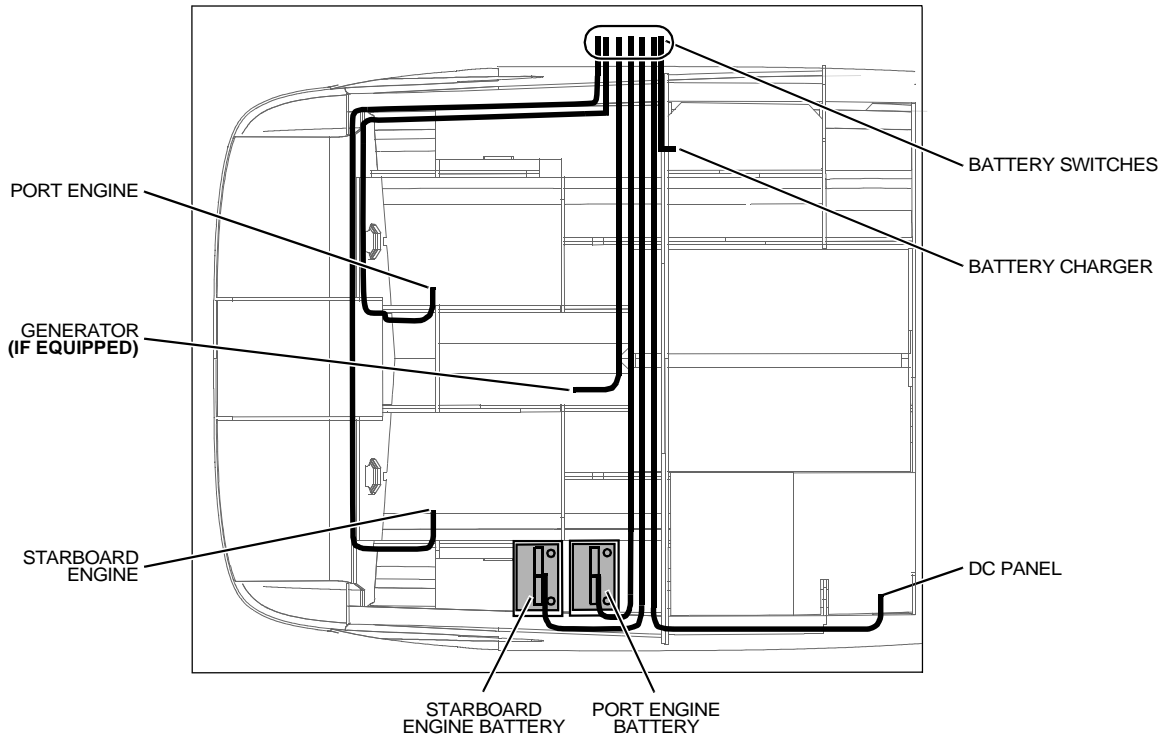

NEGATIVE BATTERY CABLE ROUTING

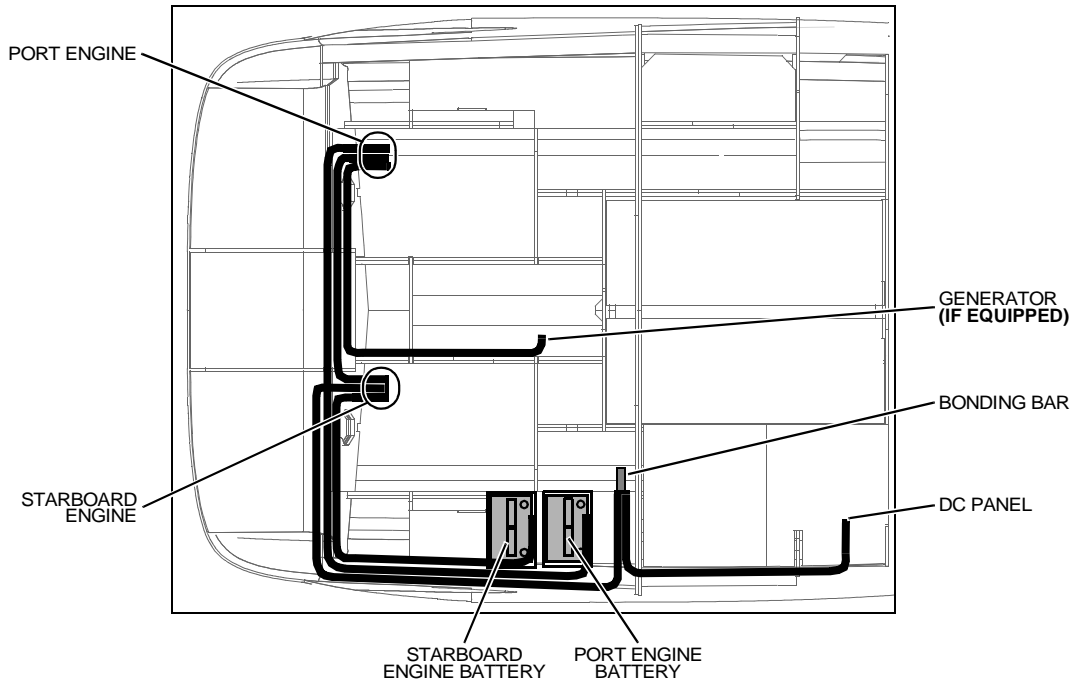

Diesel Engines Battery Cable System

NOTES:
POSITIVE BATTERY CABLES ARE RED
NEGATIVE BATTERY CABLES ARE YELLOW

POSITIVE BATTERY CABLE ROUTING

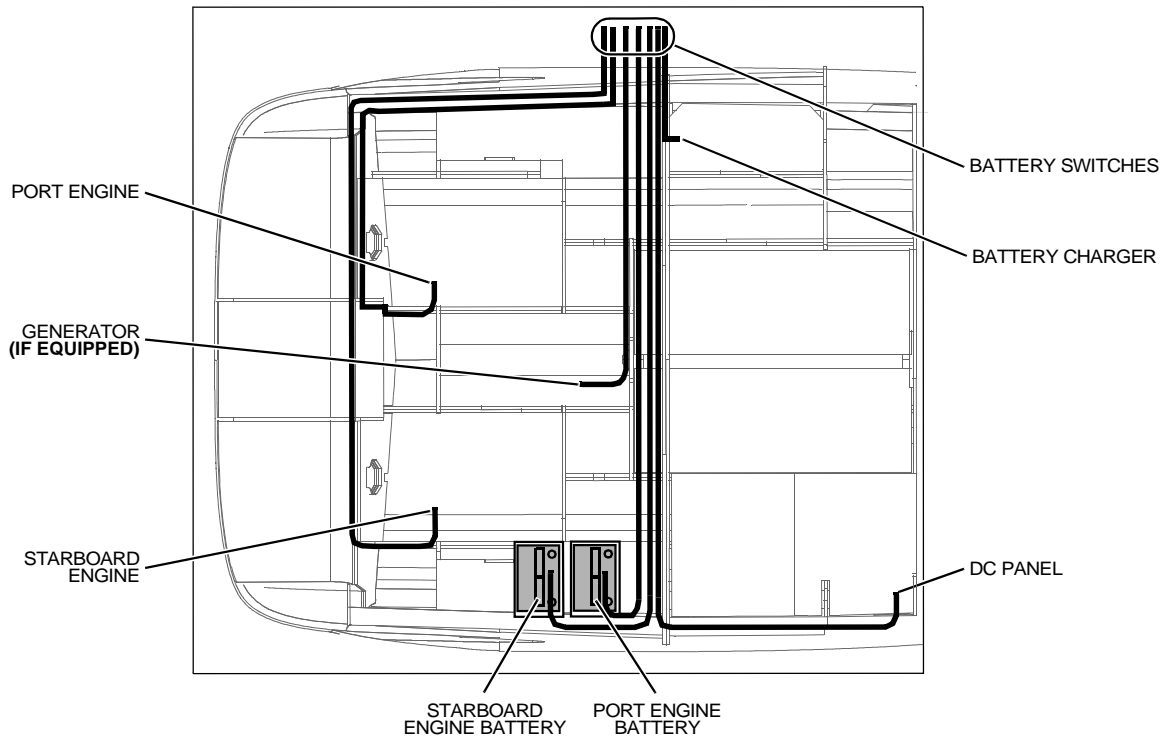

NEGATIVE BATTERY CABLE ROUTING

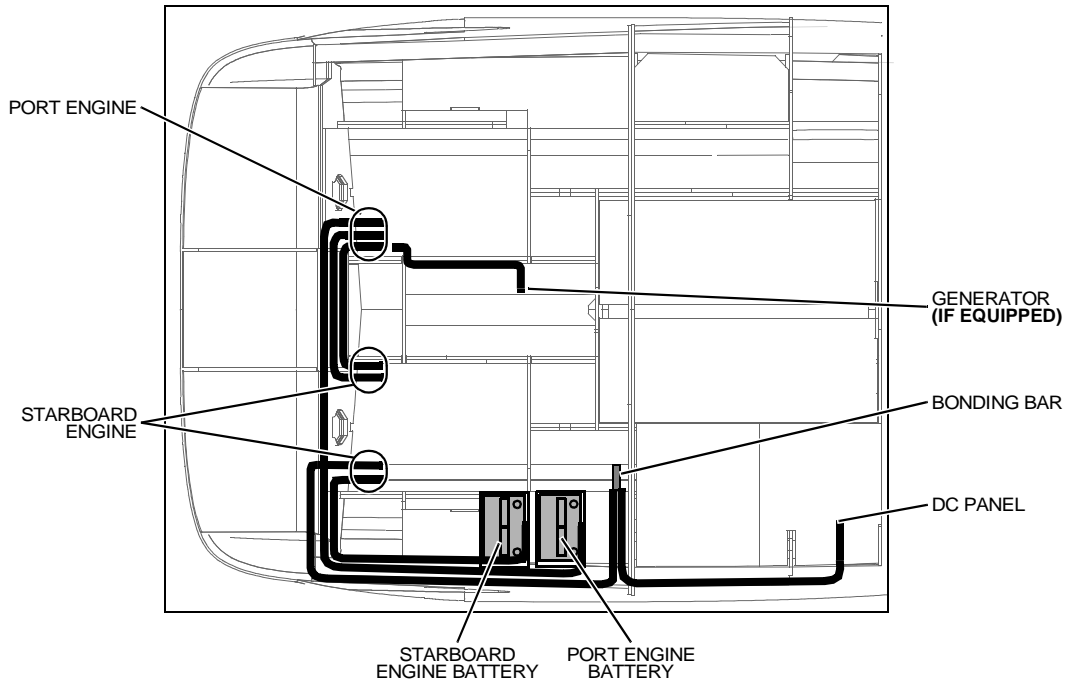

Wiring Diagrams

Engine Electrical Systems

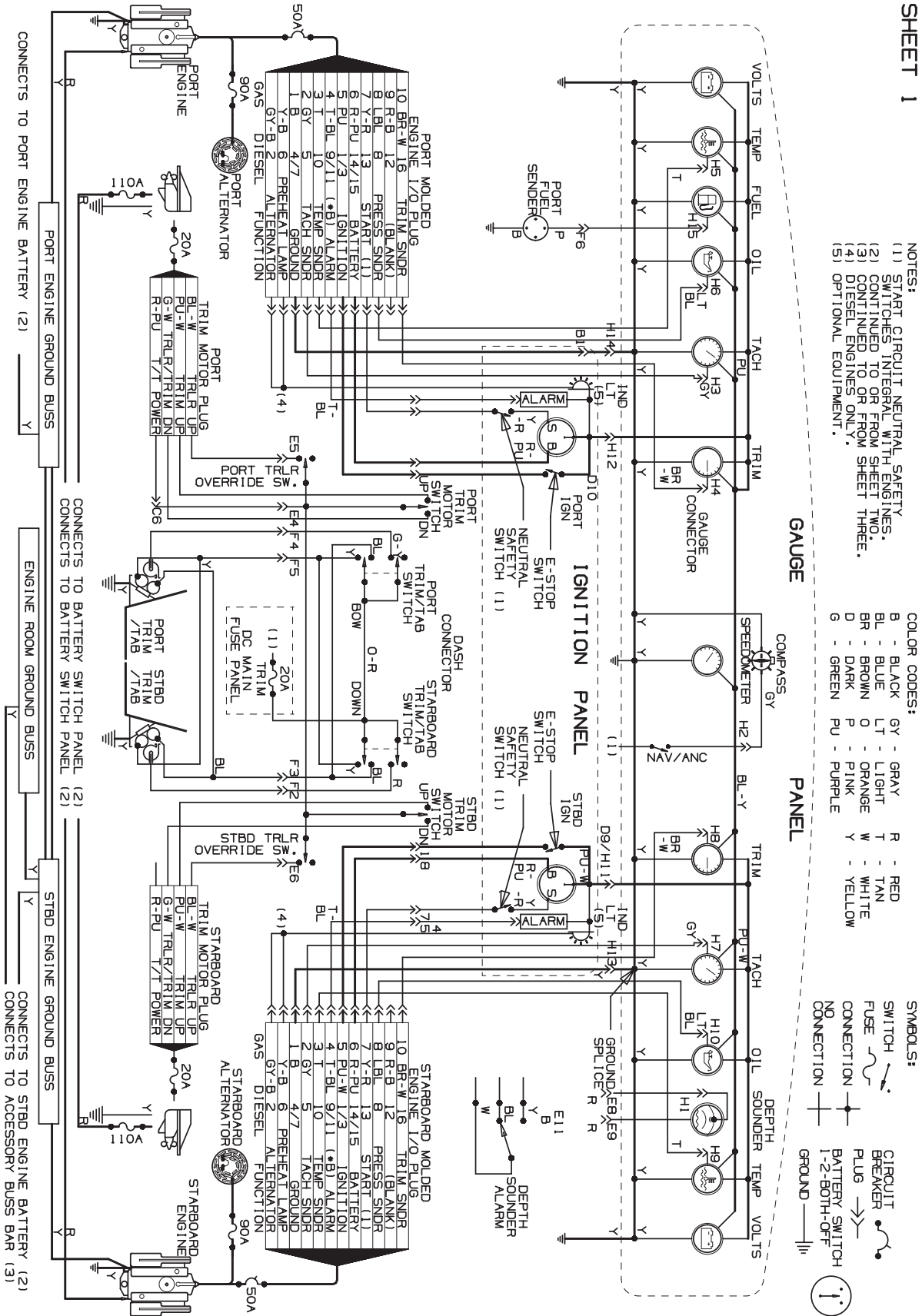

12-Volt DC Electrical System

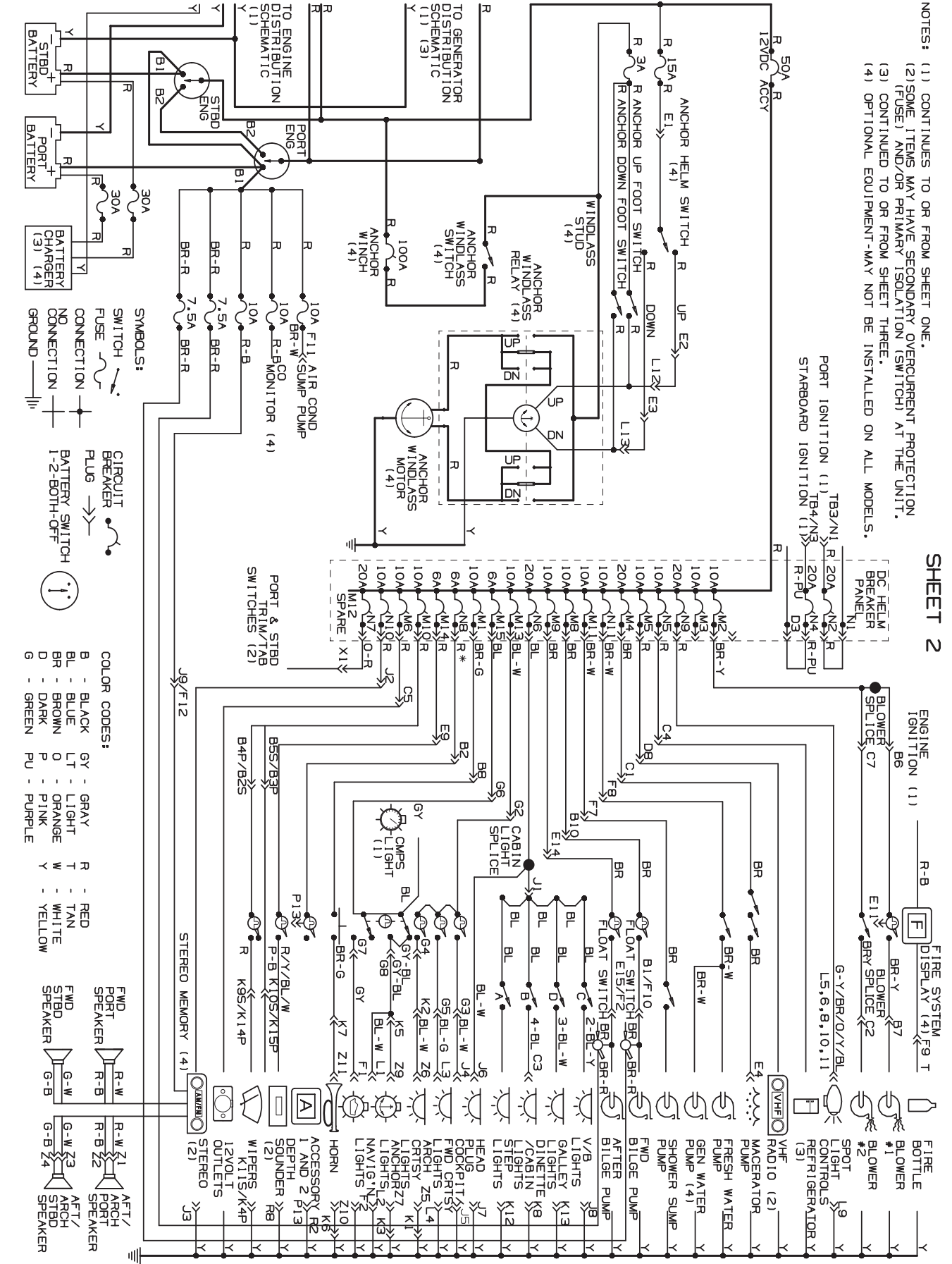

110-Volt AC Electrical System

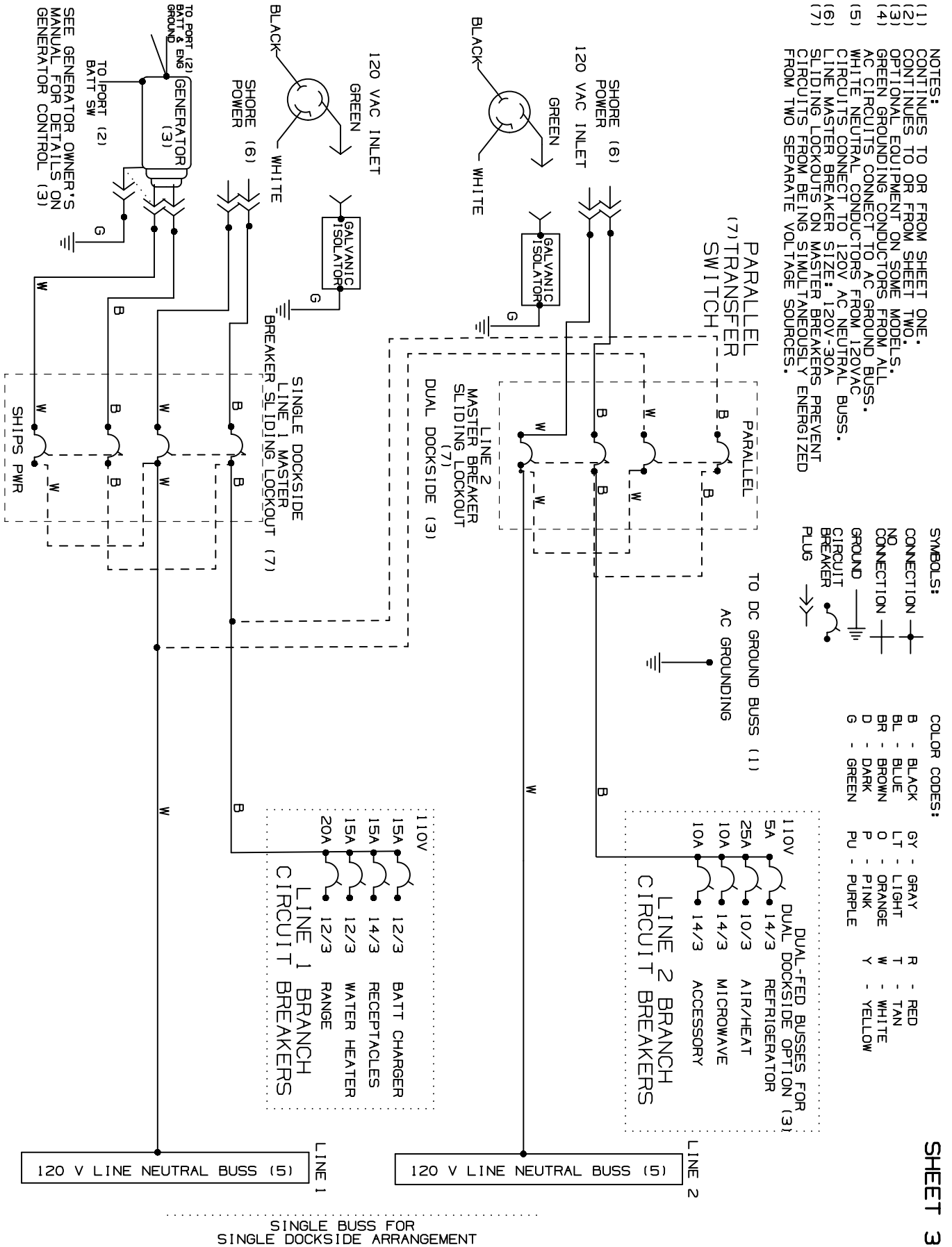

Important Records

Selling Dealer

Name Of Dealership

Address

Phone/FAX/E-mail

Sales Manager

Service Manager

Engines

Port Engine Serial Number

Starboard Engine Serial Number

Oil Type/SAE

Quarts per Engine

Filter Type

Propeller

Manufacturer

Pitch

Model Number

Generator

Manufacturer

Model Name/Number

Serial Number

Oil Type/SAE

Quarts

Filter Type

Fuel System

Fuel Capacity

Filter Type

Key Numbers

Ignition

Other

Electronics

Manufacturer

Model Name/Number

Serial Number

Manufacturer

Model Name/Number

Serial Number

Manufacturer

Model Name/Number

Serial Number

Manufacturer

Model Name/Number

Serial Number

Manufacturer

Model Name/Number

Serial Number

Float Plan

Before going boating, fill out a copy of this float plan (or similar) and leave it with a *reliable* person whom you can depend on to contact the Coast Guard or other rescue organization, if you do not return as scheduled.

Description of Boat

Registration/Documentation Number		
Length	Make	Type
Hull Color		Trim Color
Fuel Capacity	Engine Type	Number of Engines
Distinguishing Features		
Distinguishing Features		

Operator of Boat

Full Name		
Male or Female	Age	Health
Address		
Address		
Phone/FAX/E-mail		
Operator's Experience		

Persons Onboard

Full Name		
Age	Health	Phone Number
Full Name		
Age	Health	Phone Number
Full Name		
Age	Health	Phone Number
Full Name		
Age	Health	Phone Number
Full Name		
Age	Health	Phone Number
Full Name		
Age	Health	Phone Number
Full Name		
Age	Health	Phone Number

Survival Equipment

Marine Radio (Yes/No)	Type	Frequencies
Number of PFDs	Flares (Yes/No)	Mirror (yes or no)
Smoke Signals (Yes/No)	Flashlight (Yes/No)	Food (Yes/No)
Water (Yes/No)	Anchor (Yes/No)	Raft/Dinghy (Yes/No)
Paddles (Yes/No)	EPIRB (Yes/No)	Other
Other	Other	Other

Vehicle Description

Make	Model
Color	License Number
Where is the Vehicle Parked?	

Trip Expectations

Departing From	
Departure Date	Departure Time
Stopover 1	
Arrive No Later Than: Date	Arrive No Later Than: Time
Stopover 2	
Arrive No Later Than: Date	Arrive No Later Than: Time
Stopover 3	
Arrive No Later Than: Date	Arrive No Later Than: Time
Stopover 4	
Arrive No Later Than: Date	Arrive No Later Than: Time
Stopover 5	
Arrive No Later Than: Date	Arrive No Later Than: Time
Stopover 6	
Arrive No Later Than: Date	Arrive No Later Than: Time
Final Destination Port (If Different Than Home Port)	
Arrive No Later Than: Date	Arrive No Later Than: Time

If not returned by the date and time listed above, call the Coast Guard or other local authority.

Coast Guard Phone Number
Local Authority Phone Number

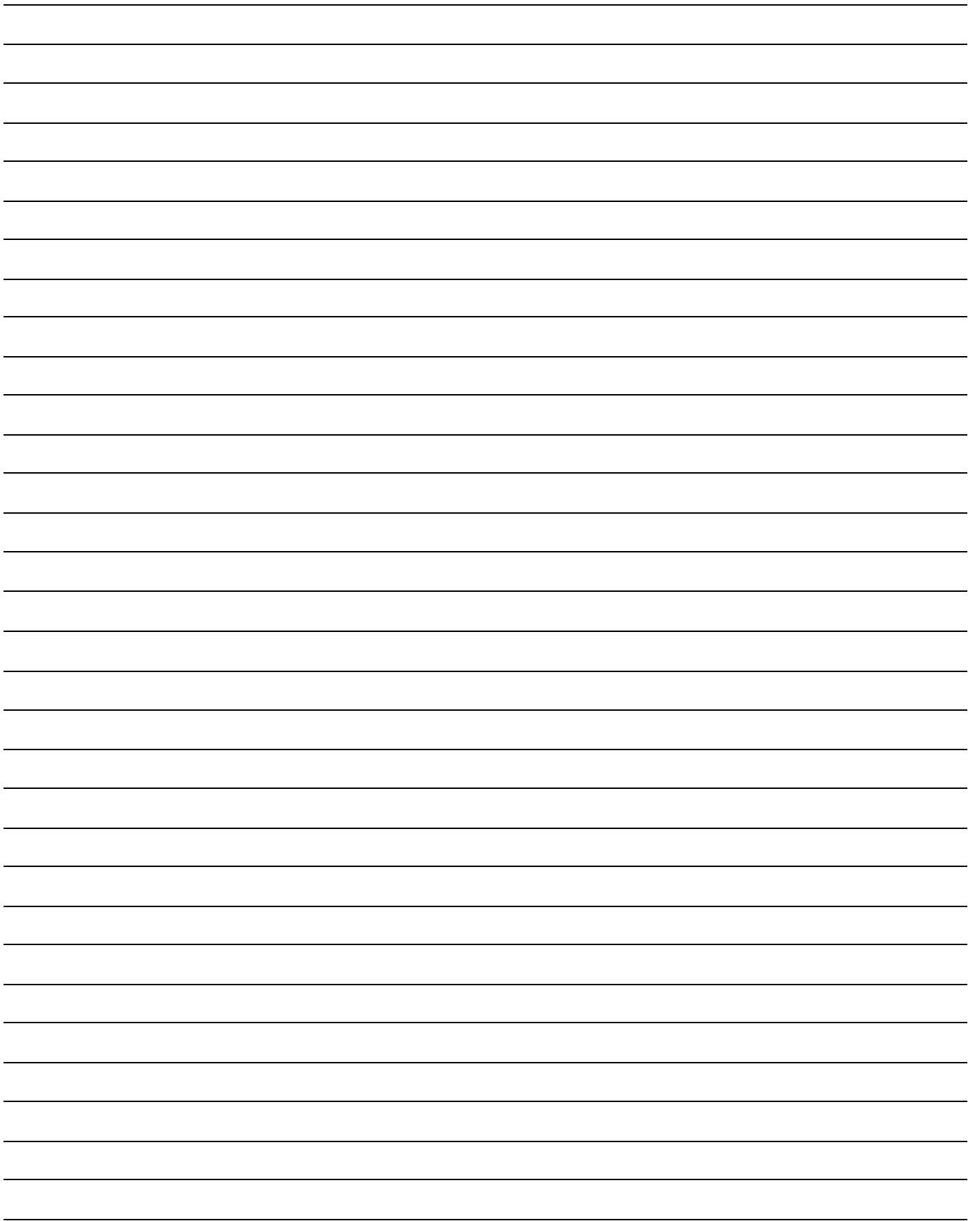

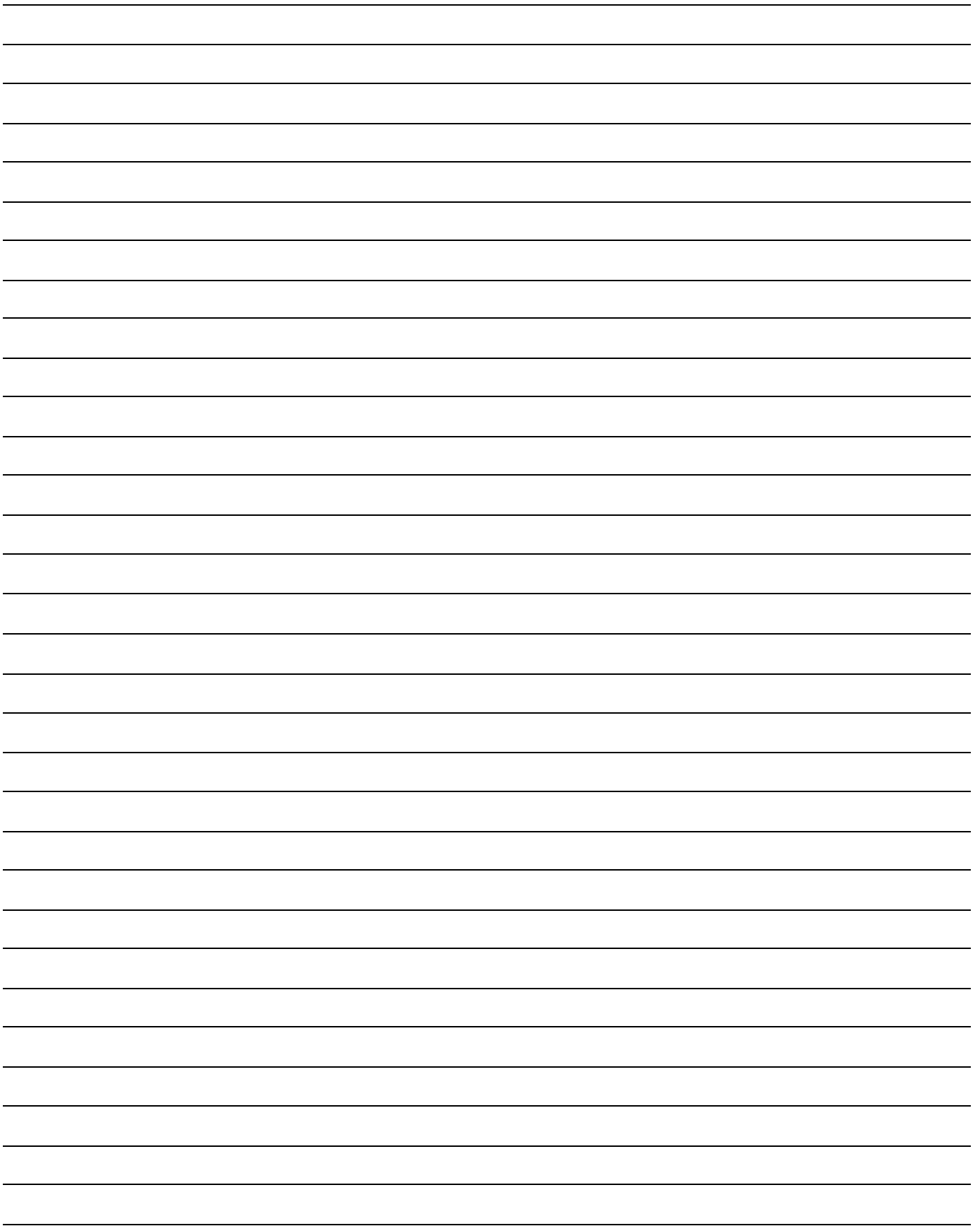

Part Number 1781922

Bayliner • P.O.Box 9029 • Everett, WA 98206 • 360-435-5571