

**OWNER'S MANUAL
SUPPLEMENT
22' - 28' CRUISERS**



Ciera

**The information provided in this Owner's Manual *Supplement*
relates to 1999 & 2000 Bayliner Ciera 22' - 28' Cruisers**

Engine Serial Number: _____

Hull Identification Number: _____

Hull Identification Number

The Hull Identification Number (HIN) is located on the starboard side of the transom. Be sure to record the HIN (and the engine serial numbers) in the space provided above. Please refer to the HIN for any correspondence or orders.

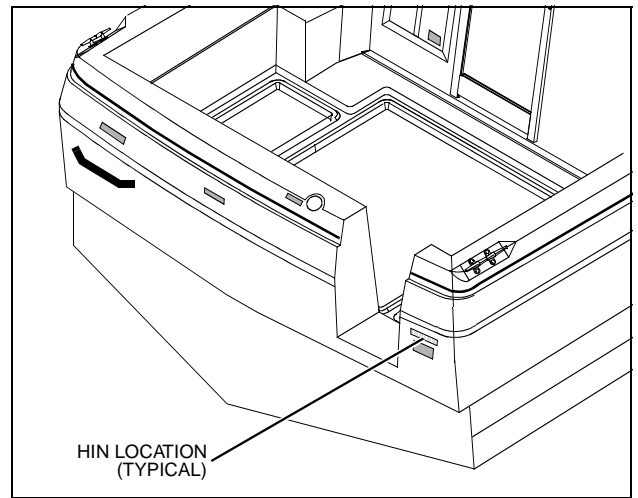

© 2000 Bayliner Marine Technical Publications. All rights reserved.

No part of this publication may be reproduced, stored in any retrieval system, or transmitted in any form by any means, electronic, mechanical, photocopying, recording or otherwise, without prior written permission of Bayliner.
Printed in the United States of America.

General Notes

The material in this document is for information only and is subject to change without notice. While reasonable efforts have been made in the preparation of this document to assure its accuracy, Bayliner assumes no liability resulting from errors or omissions in this document, or from the use of information contained herein.

Due to our commitment to product improvement, Bayliner reserves the right to make changes in the product design, specifications, and equipment at any time without notice or obligation. Illustrations and/or photos may show optional equipment.

All Bayliner products meet or exceed USCG (United States Coast Guard) and/or NMMA (National Marine Manufacturer's Association) construction standards. Manufactured with 1,1,1 Trichloroethane, a substance which harms public health and environment during the manufacturing process by destroying ozone in the upper atmosphere.

Proprietary Rights

This document discloses subject matter in which Bayliner has proprietary rights. The information and design disclosed herein were originated by and are the property of Bayliner. Neither receipt nor possession thereof confers or transfers any right to reproduce, copy, alter or disclose the document or any part thereof, any information contained therein, or to construct boats or any item from it, except by written permission from or written agreement with Bayliner. This document is to be returned upon request to Bayliner.

CONTENTS

Chapter 1: Welcome Aboard

- 1 Dealer Service
- 1 Boating Experience
- 2 Safety Standards
- 2 Engine & Accessories Guidelines
- 2 Qualified Maintenance
- 3 Structural Limitations
- 3 Special Care For Moored Boats
- 3 Sacrificial Anodes (Zincs)
- 4 Carbon Monoxide (CO)
 - 5 Sources of CO
- 5 Carbon Monoxide Alarm System
 - 5 What To Do If Carbon Monoxide Is Detected

Chapter 2: Components/Systems

- 6 Electrical System
 - 7 12 Volt DC System - Fuses and Circuit Breakers
 - 7 Battery Charger
 - 7 Shore Power/110 Volt AC System
- 9 Fresh Water System
- 9 Water Heater
- 9 110-Volt AC/12-Volt DC Refrigerator
- 10 Alcohol or Alcohol/Electric Stove
- 10 Air Conditioning (Optional)
- 11 Navigation and Interior Lights
- 11 Compass
- 11 Depth Finder
- 12 Portable toilet
- 12 Marine Head with Holding Tank
- 13 Fuel System
 - 13 Fuel Fills and Vents
 - 13 Anti-siphon Valve
 - 14 Fuel Filters
- 14 Bilge Blower
- 15 Bilge Pumps
 - 15 Locations and flow rates of bilge pumps:
 - 15 Bilge Pump Maintenance
 - 16 Autofloat Switch
- 16 Sleeper Seat Adjustment
 - 16 Fore-aft positions:
 - 16 Lounge positions:
- 17 Typical Label Locations

Chapter 3: Drawings & Diagrams

- 18 2252 Express (CP)
- 21 2355 Express (SJ)
- 25 2452 Express (CD)
- 28 2655 Sunbridge (SB)
- 30 2855 Sunbridge (ST)
- 33 2858 Command Bridge (EC)
- 38 2859 Express (SC)

Chapter 4: Wiring Diagrams

- 45 2252 Express (CP)
- 46 2355 Sunbridge (SJ)
- 47 2452 Express (CD)
- 48 2655 Sunbridge (SB)
- 49 2855 Sunbridge (ST), Gas Engine
- 50 2855 Sunbridge (ST), Diesel Engine
- 51 2858 Command Bridge (EC), Gas Engine
- 52 2858 Command Bridge (EC), Diesel Engine
- 53 2859 Express (SC), Gas Engine
- 54 2859 Express (SC), Diesel Engine
- 55 Single Dockside Wiring Diagram
- 56 Double Dockside Wiring Diagram

Limited Warranty

- 57 What Is Not Covered
- 57 Other Limitations
- 57 Your Obligation

Hazard Boxes & Symbols







The hazard boxes and symbols shown below are used throughout this supplement to call attention to potentially dangerous situations which could lead to either personal injury or product damage. **Read ALL warnings carefully and follow all safety instructions.**

 DANGER!
This box alerts you to immediate hazards which WILL cause severe personal injury or death if the warning is ignored.

 WARNING!
This box alerts you to hazards or unsafe practices which COULD result in severe personal injury or death if the warning is ignored.

 CAUTION!
This box alerts you to hazards or unsafe practices which COULD result in minor personal injury or cause product or property damage if the warning is ignored.

NOTICE
This box calls attention to installation, operation or maintenance information, which is important to proper operation but is not hazard related.

 FIRE HAZARD!	 EXPLOSION HAZARD!	 ELECTRICAL HAZARD!	 HOT HAZARD!
 CO POISONING HAZARD!	 FALLING HAZARD!	 ROTATING PROPELLER HAZARD!	
 NO OPEN FLAME!	 RUN BILGE BLOWERS FOR 4 MINUTES!		

Chapter 1: Welcome Aboard

- This Owner's Manual Supplement was prepared to provide specific information about your boat.
- Study the *Cruiser & Yacht Owner's Manual* and this supplement carefully. Pay particular attention to the LIMITED WARRANTY section.
- Keep the *Cruiser & Yacht Owner's Manual* and this supplement on your boat in a secure, yet easy to get to place.

Dealer Service

- Ask your dealer to explain all systems before taking delivery of your boat.
- Your dealer is your key to service.
- Contact your dealer if you have any problems with your new boat.
- If your dealer cannot help, call our customer service hotline: 360-435-8957 or send us a FAX: 360-403-4235.
- Buy replacement parts from any authorized Bayliner dealer.

Boating Experience

 WARNING!
<i>CONTROL HAZARD!</i> A qualified operator must be in control of the boat at all times. DO NOT operate your boat while under the influence of alcohol or drugs.

If this is your first boat or if you are changing to a type of boat you are not familiar with, for your own comfort and safety, obtain handling and operating experience before assuming command of the boat.

Take one of the boating safety classes offered by the U.S. Power Squadrons or the U.S. Coast Guard Auxiliary. For more course information, including dates and locations of upcoming classes, contact the organizations directly:

- U.S. Power Squadrons: 1-888-FOR-USPS (1-888-367-8777) or on the Internet at: <http://www.usps.org>
- U.S. Coast Guard Auxiliary: 1-800-368-5647 or on the Internet at: <http://www.cgaux.org>

Outside the United States, your selling dealer, national sailing federation or local boat club can advise you of local sea schools or competent instructors.

Safety Standards

⚠ DANGER!



PERSONAL SAFETY HAZARD! DO NOT allow anyone to ride on parts of the boat not designated for such use. **Sitting on seat backs, lounging on the forward deck, bow riding, gunwale riding or occupying the transom platform while underway is especially hazardous and will cause personal injury or death.**

⚠ DANGER!

PERSONAL SAFETY HAZARD! ALWAYS secure the anchor and other loose objects before getting underway. **The anchor and other items that are not properly secured can come loose when the boat is moving and cause personal injury or death.**

Your boat's mechanical and electrical systems were designed to meet safety standards in effect at the time it was built. Some of these standards were mandated by law, all of them were designed to insure your safety, and the safety of other people, vessels and property.

In addition to this owner's manual supplement, please read the *Cruiser & Yacht Owner's Manual* and all accessory instructions for important safety standards and hazard information.

Engine & Accessories Guidelines

NOTICE

When storing your boat please refer to your engine's operation and maintenance manuals.

Your boat's engine and accessories were selected to provide optimum performance and service. Installing a different engine or other accessories may cause unwanted handling characteristics. Should you choose to install a different engine or to add accessories that will affect the boat's running trim, have an experienced marine technician perform a safety inspection and handling test before operating your boat again.

Certain modifications to your boat can result in cancellation of your warranty protection. Always check with your dealer before making any modifications to your boat.

The engine and accessories installed on your boat come with their own operation and maintenance manuals. Read and understand these manuals before using the engine and accessories.

Qualified Maintenance

⚠ WARNING!

To maintain the integrity and safety of your boat, allow only qualified personnel to perform maintenance on, or in any way modify: The steering system, propulsion system, engine control system, fuel system, environmental control system, electrical system or navigational system.

Failure to maintain your boat's systems (listed in the warning above) as designed could violate the laws in your jurisdiction and could expose you and other people to the danger of bodily injury or accidental death. Follow the instructions provided in the *Cruiser & Yacht Owner's Manual*, this *Owner's Manual Supplement*, the engine owner's manual and all accessory instruction sheets and manuals included in your boat's owner's packet.

Structural Limitations

If equipped, the transom platform and bow platform are designed to be lightweight for proper boat balance. The load limit for these platforms is 30 pounds per square foot, evenly distributed.

Special Care For Moored Boats

NOTICE

- To help seal the hull bottom and reduce the possibility of gelcoat blistering on moored boats, apply an epoxy barrier coating, such as INTERLUX, *Interprotect 2000E/2001E*. The barrier coating should be covered with several coats of anti-fouling paint.
- Many states regulate the chemical content of bottom paints in order to meet environmental standards. Check with your local dealer about recommended bottom paints, and about the laws in effect in your area.

Whether moored in saltwater or freshwater, your boat will collect marine growth on its hull bottom. This will detract from the boat's beauty, greatly affect its performance and may damage the gelcoat.

- Periodically haul the boat out of the water and scrub the hull bottom with a bristle brush and a solution of soap and water.

Sacrificial Anodes (Zincs)

NOTICE

Do not paint between the zinc and the metal surface it contacts and do not paint over the zincs.

Your boat is equipped with sacrificial anodes (zincs) to protect underwater metal parts from excessive deterioration. Check the zincs regularly and replace them if they have deteriorated more than 70%.

There are many factors that affect the rate at which the zincs deteriorate, including:

- Water temperature
- Salinity
- Water pollution

Stray electrical current from the boat or dock may cause complete deterioration in just a few weeks. If there is rapid zinc deterioration, measure the electrolytic corrosion around your boat with a Corrosion Test Meter. If the zincs are not bonded correctly, they will not provide protection.

Carbon Monoxide (CO)

 **DANGER!**



CARBON MONOXIDE POISONING HAZARD!

Carbon monoxide gas (CO) is colorless, odorless, and extremely dangerous. All engines, generators, and fuel burning appliances produce CO as exhaust. Direct and prolonged exposure to CO will cause BRAIN DAMAGE or DEATH.

Signs of CO poisoning include:

- **Headache**
- **Nausea**
- **Dizziness**
- **Drowsiness**

- CO poisoning causes a significant number of boating deaths each year.
- Called the "silent killer", CO is an extremely toxic, colorless, odorless and tasteless gas.
- Breathing CO blocks the ability of your blood to carry oxygen.
- The effects are cumulative, even low levels of exposure can result in injury or death.

Factors increasing the effects of CO poisoning include:

- Age
- Smokers or people exposed to high concentrations of cigarette smoke
- Consumption of alcohol
- Lung disorders
- Heart problems
- Pregnancy

Sources of CO

Sources of CO include:

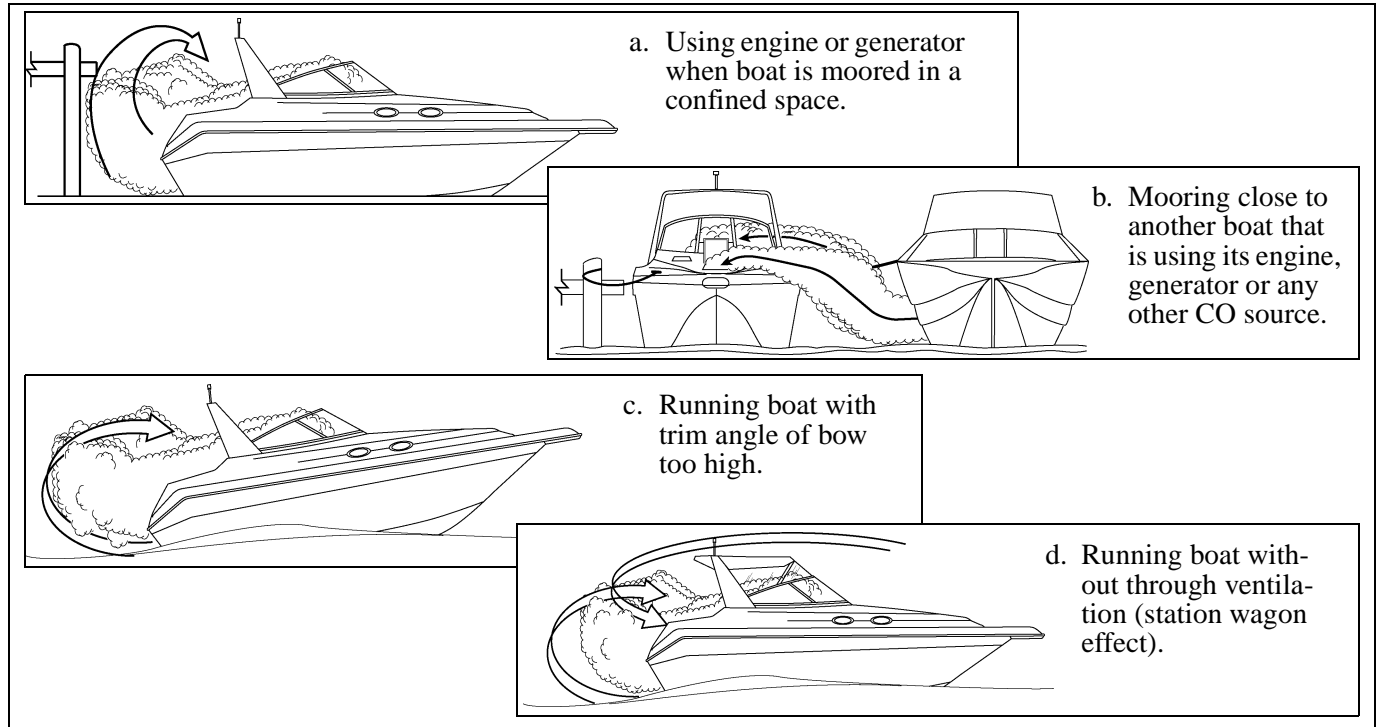

To correct stationary situations (a) and/or (b):

- Close all windows, portlights and hatches.
- If possible, move your boat away from the source of CO.

To correct running situations (c) and/or (d):

- Trim bow down.
- Open windows and canvas.
- When possible, run boat so that prevailing winds will help dissipate exhaust.

Immediately take corrective action if CO is detected or suspected (see, *Carbon Monoxide Alarm System*, below).

Carbon Monoxide Alarm System

- Your boat features a carbon monoxide (CO) alarm system.
- **Do not disconnect the alarm system.**
- Read and understand the manufacturer's instructions for your CO alarm system. If you did not receive an instruction manual, call (800) 383-0269 and one will be mailed to you.
- If your boat is not equipped with a carbon monoxide alarm, consider purchasing one from your dealer or marine supply store.

What To Do If Carbon Monoxide Is Detected



- Immediately ventilate and evacuate any enclosed spaces that are occupied by people and reset your CO alarm.
- Immediately move anyone showing any symptoms of CO poisoning into fresh air.
- See a doctor if any symptoms persist. If the person is unconscious, immediately administer oxygen or CPR and call for emergency help.

Chapter 2: Components/Systems

Electrical System

We strongly recommend that you read and understand the Electrical Section of the Owner's Manual.





⚠ DANGER

EXTREME FIRE/EXPLOSION HAZARD!

- To minimize the risks of fire and explosion, **NEVER** install knife switches or other arcing devices in the fuel compartments.
- **NEVER** substitute automotive parts for marine parts. Electrical, ignition and fuel system parts were designed and manufactured to comply with rules and regulations that minimize risks of fire and explosion.
- **DO NOT** modify the electrical systems or relevant drawings.
- Only qualified personnel should install batteries and/or perform electrical system maintenance.
- Insure that all battery switches are in the OFF position before performing any work in the engine spaces.

⚠ WARNING

FIRE/EXPLOSION HAZARD!

- Fuel fumes are heavier than air and will collect in the bilge areas where they can be accidentally ignited. Visually and by smell (sniff test), check the engine and fuel compartments for fumes or accumulation of fuel. Operate the bilge blower for at least four minutes prior to engine starting, electrical system maintenance or activation of electrical devices.
- Minimize the danger of fire and explosion by not exposing batteries to open flame or sparks. It is also important that no one smoke anywhere near the batteries.

⚠ CAUTION



SHOCK/ELECTRICAL SYSTEM DAMAGE HAZARD!

- Never disconnect the battery cables while the engine is running as this can cause damage to your boat's electrical system components.
- The battery charging systems (alternator and, if applicable, battery charger) installed on your boat are designed to charge conventional lead-acid batteries. Before installing gel-cell or other new technology batteries, consult with the battery manufacturer about charging system requirements.

NOTICE

- Electrical connections are susceptible to corrosion. Minimize electrical problems due to corrosion by keeping all exposed electrical connections clean and protected with with a spray-on protectant such as Corrosion Guard®.
- **VOLTAGES** - All boats use either 110-volt AC/60 Hertz, 240-volt AC/60 Hertz or 220-volt AC/50 Hertz single phase systems, and 12-volt DC or 24-volt DC. Electrical distribution panels are labeled with voltage and frequency of AC and DC.

12 Volt DC System - Fuses and Circuit Breakers

Both the engine and accessory circuits are protected by a large circuit breaker located on the engine. In addition, a fuse block for branch accessory circuits is located behind the helm panel. Wires are color-coded to indicate which accessory each fuse services. Some items, such as radios and bilge pumps, may be fused individually at the unit. Autofloat switches are fused at the battery.

Battery Charger

Your boat may be equipped with a battery charger. Please refer to the manufacturer's operating instructions included in the boat's owner's packet. The battery charger operates when AC dockside power is connected and the battery charger circuit breaker is ON. The battery charger will charge batteries regardless of the battery switch position.



CAUTION

The battery charger is designed to charge conventional lead-acid batteries. Before installing gel-cell or other new technology batteries, consult with the battery manufacturer about charging system requirements.

Shore Power/110 Volt AC System

Your boat may be equipped with an AC system. AC systems are energized by dockside shore power. Standard dockside receptacles and cords provided are rated at 30 amps. Since some shore installations do not have 30 amp service, we recommend the purchase of 15 amp and 20 amp adapters. **Note:** When 15 amp or 20 amp adapters are used there will be a corresponding drop in supplied AC power.



DANGER



FIRE/EXPLOSION/SHOCK HAZARD!

- To minimize shock and fire hazard, **DO NOT** modify electrical systems or relevant drawings.
- **DO NOT** alter shore power connectors and use only compatible connectors.
- Only qualified personnel should install batteries and/or perform electrical system maintenance.



CAUTION



SHOCK/ELECTRICAL SYSTEM DAMAGE HAZARD!

- Never connect dockside power to your boat outside North America unless you have purchased the International electrical conversion option, which is rated for 220-volt/50 Hertz. North American systems are rated for 110-volt/60 Hertz power.
- Use double insulated or three-wire protected electrical appliances when possible.

NOTICE

When using shore power, the simultaneous operation of several AC accessories can result in an overloaded circuit. It may be necessary to turn off one accessory while operating another.

! WARNING

FIRE/EXPLOSION/SHOCK/ELECTRICAL SYSTEM DAMAGE HAZARD!

Before connecting to shore power, all breakers and switches on the AC master panel must be in the OFF position. Always attach the shore power cord to the boat inlet first, then to the dock connection, thereby avoiding accidental submersion of the "HOT" cord into the water. To disconnect, first remove the dock connection before removing the cord from the boat.

! WARNING

FIRE/EXPLOSION/SHOCK/ELECTRICAL SYSTEM DAMAGE HAZARD!

Monitor the electrical control panel's polarity indicators when connecting shore power to your boat. A **GREEN** light illuminating after the power cord is plugged into the boat's external power receptacle indicates acceptable electrical power in which you may energize the main breaker switches. A **RED** light, however, indicates reversed polarity, which could cause electrical system damage and possibly electrical shock injuries. In this case, **DO NOT** energize the main breaker switches. Instead, immediately disconnect the shore power cord (always from the dockside outlet first) and notify marina management.

! CAUTION

WATER HEATER DAMAGE HAZARD! DO NOT energize the AC water heater electrical circuit until the heater is *completely* filled with water. Even momentary operation in a dry tank will damage the heating elements. Warranty replacements *will not* be made on elements or tank damaged in this manner. The tank is full if water flows from the tap when the hot water is turned on in the galley.

The diagram shows a detailed view of the AC master panel. On the left, there are two master breakers labeled 'LINE 1' and 'LINE 2', each with a 'CAUTION POLARITY REVERSED' indicator. Below them is a 'VOLTAGE SELECTOR' with 'LINE 1' and 'LINE 2' options. To the right, there are several receptacles for 'BATTERY CHARGER', 'WATER HEATER', 'RANGE', 'REFRIGERATOR', 'AIR CONDITIONER', and 'SPARE'. A callout points to a 'TYPICAL SHORE POWER RECEPTACLE' which is a white plastic unit with a 'SHORE POWER WARNING' label. Another callout points to the 'TYPICAL AC POWER PANEL' which is the main control unit.

On boats with a single dockside inlet, check for proper polarity as outlined in the previous warning. Activate the AC system by first turning on the master breaker, then each individual component breaker as required.

On boats with dual dockside inlets, check for proper polarity as outlined in the previous warning. Each dockside inlet is labeled inside the weather-proof cover, line 1 or line 2, which corresponds to the line each operates on the AC master panel. This system is designed so that each line operates independent of each other. Activate the AC system by first turning on the master breakers, then each individual component as required.

Fresh Water System

Fresh water systems are available on some models. These pressure-type (demand) systems operate when the water pump switch (located near the sink in the cuddy cabin) is in the ON position. Turn the pump switch OFF when the boat is not in use and when the water tank is empty.

Stored water can become stagnant and distasteful. Pump the water tank dry before leaving your boat unattended for long periods of time. Occasionally you may want to disinfect your water system. Ask your selling dealer about available treatments and procedures.

Your boat may be equipped with a shower. Please read and follow the manufacturer's operating instructions supplied in the owner's packet.

Water Heater

Your boat may come equipped with a water heater. Be sure to refer to the manufacturer's operating instructions supplied in the owner's packet. The water heater is connected to the AC power system. If your boat is equipped with optional freshwater engine cooling, the coolant from the closed engine cooling system may be circulated through the hot water tank for heating of potable water.



CAUTION

WATER HEATER DAMAGE HAZARD! DO NOT energize the AC water heater electrical circuit until the heater is *completely* filled with water. Even momentary operation in a dry tank will damage the heating elements. Warranty replacements *will not* be made on elements or tank damaged in this manner. The tank is full if water flows from the tap when the hot water is turned on in the galley.

110-Volt AC/12-Volt DC Refrigerator

Your boat may come equipped with a 110-volt AC/12-volt DC refrigerator. Please refer to the manufacturer's instructions included in the boat's owner's packet. The refrigerator operates on 110-volt AC and 12-volt DC power. When the 110-volt AC system is not hooked up to an AC source, the refrigerator operates on 12-volts DC. When a 110-volt AC source is supplied by dockside power and the AC refrigerator breaker is ON, the refrigerator automatically switches to 110-volt AC.

NOTICE

The refrigerator has the heaviest continuous draw on the 12-volt system. In less than 24 hours, the refrigerator can render a 100-amp battery useless for engine starting. For this reason, it is recommended that when operating on 12-volts, the cold setting on the refrigerator should not be set higher than position two (2). It is also advisable to turn off your refrigerator at night or when not in use. If you are going to be out for more than one day and cannot connect to dockside power, you should plan to run the engine each day to maintain a charged battery.

Alcohol or Alcohol/Electric Stove

Operating instructions for the alcohol or alcohol/electric stove can be found in the boat's owner's packet. Carefully read and follow the manufacturer's operating instructions and warnings before using the stove.

⚠ WARNING

FIRE HAZARD - Reduce the possibility of fire by removing all combustibile materials away from the stove before/during use.

⚠ WARNING

FIRE/PERSONAL INJURY HAZARD - Before each use of the 2858 (EC) galley stove, the lower helm seat's back rest **MUST** be lowered into the counter top position to reduce the possibility of fire or injury (see drawing below).

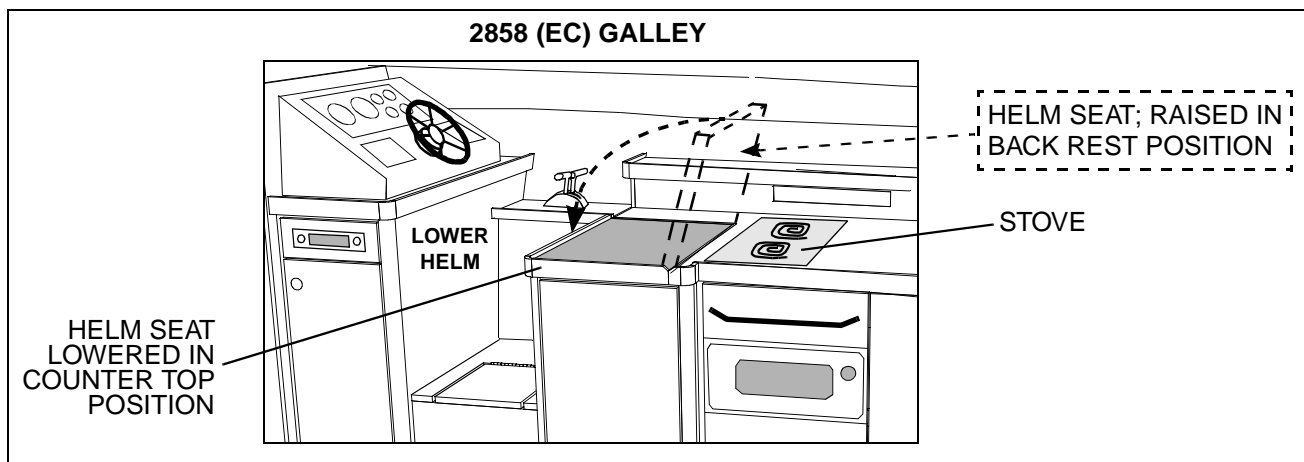

Air Conditioning (Optional)

Your boat may be equipped with an optional air conditioning system. Please refer to the manufacturer's operating instructions included in your boat's owner's packet.

Navigation and Interior Lights

We strongly recommend that you understand navigation light usage by reading the navigation section of the Owner's Manual. The navigation and interior lights supplied with your boat are of top quality, but you should be aware that failure may periodically occur for a variety of reasons:

1. There may be a blown fuse (Replace the fuse in the switch panel).
2. The bulb may be burned out (Carry spare bulbs for replacement).
3. The bulb base may be corroded (Clean the base periodically and coat it with non-conductive grease).
4. A wire may have come loose or may be damaged (Repair as required).



CAUTION

- **Avoid the storage of gear where it would block navigation lights from view.**
- **Prolonged operation of cabin interior lights (overnight) will result in a drained battery. Be conservative in the use of battery power.**

Compass

Your boat may come equipped with a compass. Carefully read and follow the manufacturer's calibration and operating instructions provided in the boat's owner's packet.

Depth Finder

Your boat may come equipped with a depth finder. It will provide you with measurements of water depth beneath the boat. In many cases it may help you locate schools of fish. We suggest that you read the manufacturer's owner's operating instructions included in the boat's owner's packet before using the unit.



WARNING

DO NOT use the depth finder as a navigational aid to prevent collision, grounding, boat damage or personal injury. When the boat is moving, submerged objects will not be seen until they are already under the boat. Bottom depths may change too quickly to allow time for the boat operator to react. If you suspect shallow water or submerged objects, operate the boat at very slow speeds.

Portable toilet

Your boat may come equipped with a portable toilet. Be sure to read and carefully follow the manufacturer's operating instructions included in your boat's owner's packet.

Marine Head with Holding Tank

Your boat may come equipped with with a marine head and holding tank. Be sure to follow the manufacturer's operating instructions included in the boat's owner's packet.

Seawater is used to flush waste from the toilet into the holding tank. The holding tank is plumbed to a waste fitting on the deck for use at a dockside pump-out station, and to a macerator pump so that waste may be pumped overboard (where regulations permit). The switch for the macerator is usually located at the helm station.

If at any time you are unable to pump water into the bowl, the probable cause is debris in the pump diaphragm. To remedy this, shut the inlet seacock and dismantle the pump. The pump is generally held together with six screws. The design is simple and the problem will be obvious when the pump body is split open.

To winterize the toilet, shut off the intake valve and pump until the bowl is dry. Remove the drain plug in the base and pump again to remove all water. Do not fill the bowl with antifreeze. The inlet seacock should be left closed while the boat is underway, or whenever the boat is left moored in the water.

Fuel System



WARNING



FIRE/EXPLOSION HAZARD - It is very important that the fuel system be inspected thoroughly the first time it is filled and at each subsequent filling. For your safety and the safety of your passengers, the fueling instructions in the Owner's Manual must be carefully followed.

NOTICE

Air in the diesel supply system (if equipped) can stop an engine or severely restrict performance. If you suspect air in your diesel fuel lines, refer to your engine owner's manual for detailed instructions on how to "bleed" the system.



CAUTION

Avoid the storage or handling of gear near the fuel lines, fittings and tank.

Fuel Fills and Vents

Fuel fills are located either on the aft deck or on the side decks adjacent to the aft cockpit. Fuel receptacle caps are marked "Diesel" or "GAS". Fuel vents are normally located in the hull or transom below and in the same general area as the fill. If you experience difficulty filling the fuel tank, check to see that the fuel fill and vent lines are free of obstructions and kinks.

Anti-siphon Valve

Your boat may be equipped with an anti-siphon valve, which is an integral part of the barb fitting on the fuel tank in which the neoprene fuel line attaches. The valve is spring loaded and is opened by fuel pump vacuum. These valves will prevent fuel from siphoning from the tank in the event of a fuel line rupture.

NOTICE

If an engine running problem is diagnosed as fuel starvation, check the anti-siphon valve. In the event the valve is stuck or clogged, it should be changed or replaced while the engine is shut down. Under NO circumstances should the anti-siphon valve be removed, except in an emergency.

Fuel Filters

All tanks are equipped with a fine mesh screen filter on the fuel pickup tube (located inside or on the outside of the tank) to the fuel line fitting. In addition, when supplied by the engine manufacturer, an additional filter is installed on the engine. Fuel filters should be replaced periodically to ensure they remain clean and free of debris. Consult your selling dealer or local marina concerning fuel additives that help to prevent fungus or buildup in your fuel tanks.

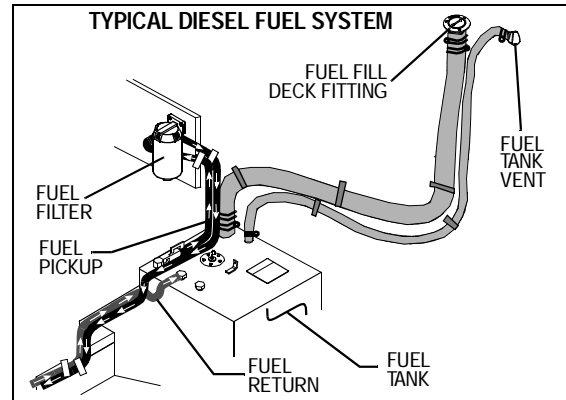
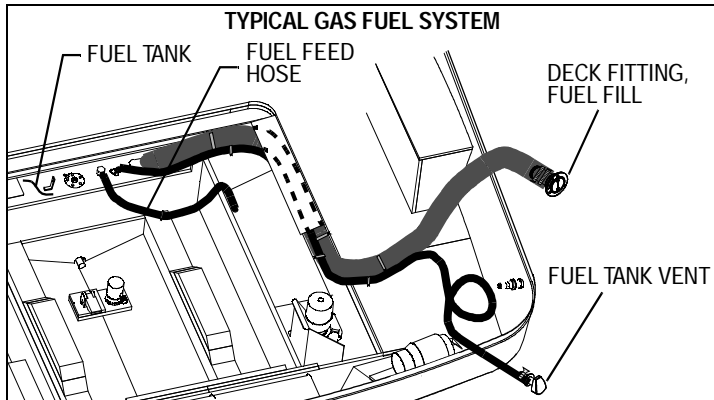

Bilge Blower

The bilge blower removes fumes from the engine compartment and draws fresh air into the compartment through the deck vents. To ensure fresh air circulation, operate the bilge blower for at least four minutes before starting the engine, during starting, and while operating the boat below cruising speed.

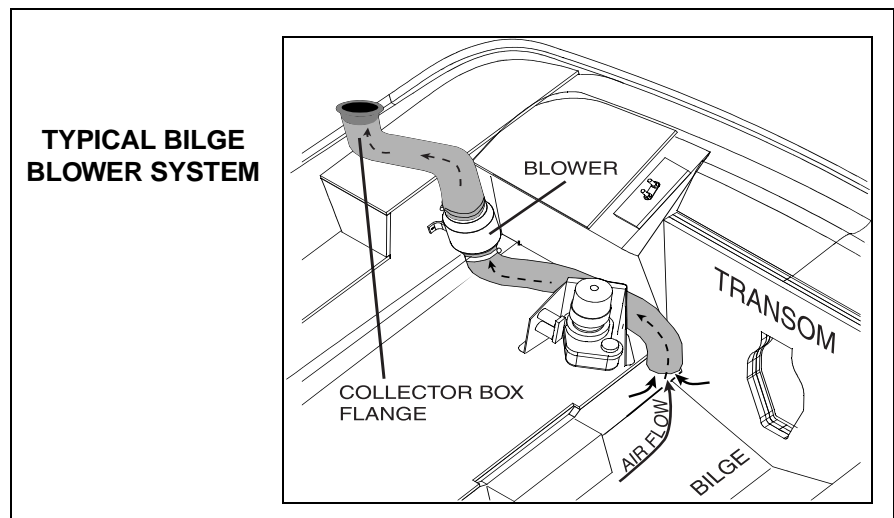

WARNING



Operation of the blower system is **NOT A GUARANTEE** that explosive fumes have been removed. If you smell any fuel, **DO NOT** start the engine. If the engine is already running, immediately shut off the engine and all electrical accessories. Investigate immediately. **DO NOT** obstruct or modify the ventilation system.

Bilge Pumps

Your boat is equipped with two impeller-type bilge pumps. They are controlled by a switch on the dash panel, which should be activated whenever water begins to accumulate in the bilge. Some models will also have an automatic bilge pump switch (“autofloat switch”), mounted next to the bilge pump. This is a float-type switch that will activate a bilge pump automatically whenever the bilge water accumulates above a pre-set level. It is wired directly to the battery so it will normally function even when the boat is completely shut down and unattended, such as when the boat is moored at a marina.

Locations and flow rates of bilge pumps:

Model	Aft (8.3 gpm)	Aft (20.83 gpm)	Fwd (8.3 gpm)
2252 (CP)		✓	✓
2355 (SJ)	✓		✓
2452 (CD)		✓	✓
2655 (SB)		✓	✓
2585 (EC)		✓	✓
2859 (SC)		✓	✓

Bilge Pump Maintenance

Bilge pumps should be checked often to verify that they are working properly. To check a bilge pump's operation, activate the dash-mounted switch. Verify that water in the bilge is pumped overboard. If bilge water is present and the pump motor is running but not pumping, inspect the discharge hose for a kink or collapsed area. If no problems are found, check the bilge pump housing for clogging debris:

To remove the power cartridge:

1. Lift the tab while rotating the fins counter-clockwise and lift out the power cartridge (Fig. 1).
2. Clear the housing of debris.

To reinstall the power cartridge:

1. Make sure the “O” ring is properly located and coat the “O” ring with a light film of vegetable oil or mineral oil (Fig. 2).
2. Align the two cams on either side of the power cartridge with the two slots on the outer housing. Press the power cartridge into the housing and twist clockwise. Ensure proper reinstallation by attempting to twist the fins counter-clockwise without lifting the tab. The cartridge should stay in place.

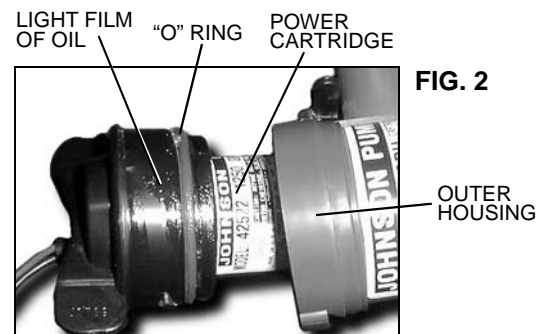
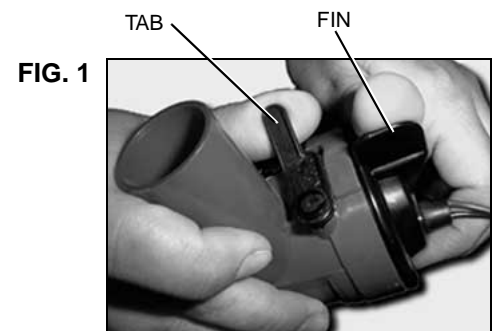

Autofloat Switch

If applicable, the autofloat switch should also be checked often for proper operation. Lift the float by turning the plastic insert where the wires enter the housing, 1/4 turn counter-clockwise (Fig. 3).

As the float is lifted, the bilge pump should turn on. If lifting the float does not turn the pump on, check the inline fuse. If the fuse is good but the switch does not work, it may indicate a bad switch or possibly a low battery

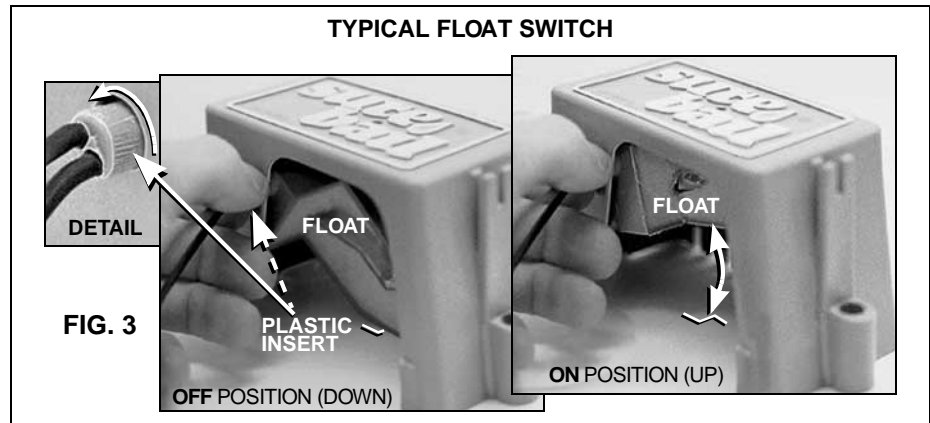

NOTICE

Discharge of oil, oil waste or fuel into navigable waters is prohibited by law. Violators are subject to legal action by the local authorities.

Sleeper Seat Adjustment

Your boat may be equipped with adjustable sleeper seats. These seats can be adjusted fore and aft in the upright position. The seat bottoms of these models also adjust into backrests while the seats are in the lounge position.

Fore-aft positions:

To slide a seat forward or backward, lift up on the front edge of the seat bottom (A). Move the seat forward until the locking mechanism engages in one of the three different positions. Lift the aft seat at point (B) and slide the aft seat towards the forward seat.

Lounge positions:

1. To put the seat into the lounge position, lift up on the front edge of the seat (A) and pull the seat all the way forward. Lift the aft seat at (B) and pull the aft seat away from the forward seat until the seat is laid out flat.
2. Lift up on the forward or aft seat bottom at point (C) until the seat bottom drops into the locked position.
3. To lower the seat bottom, lift the seat at points (C) and (D) at the same time. Drop the seat bottom flat while holding the seat up at point (D).
4. To return the seat to the operating position, lift the seat back at point (E) and push the seat bottom toward the center of the seat until it locks into place.

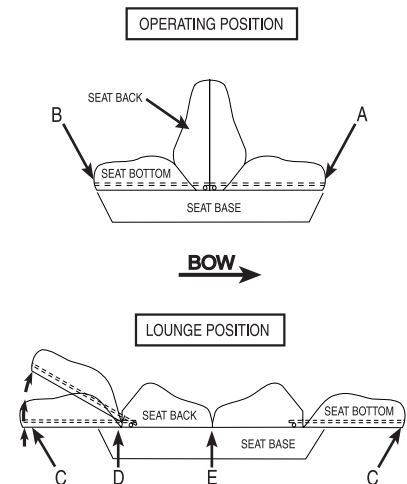

Typical Label Locations

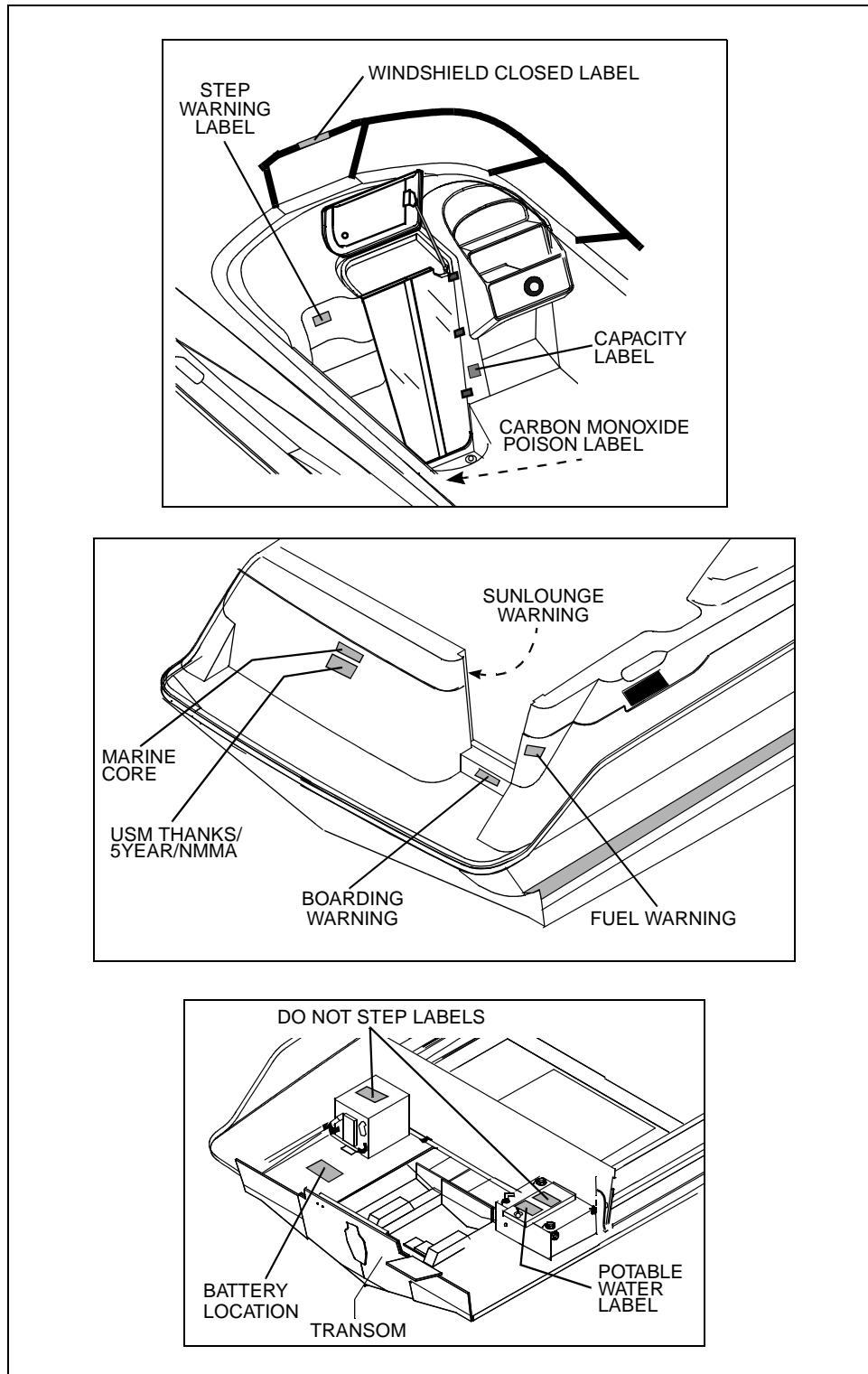

Chapter 3: Drawings & Diagrams

2252 Express (CP)

Layout View

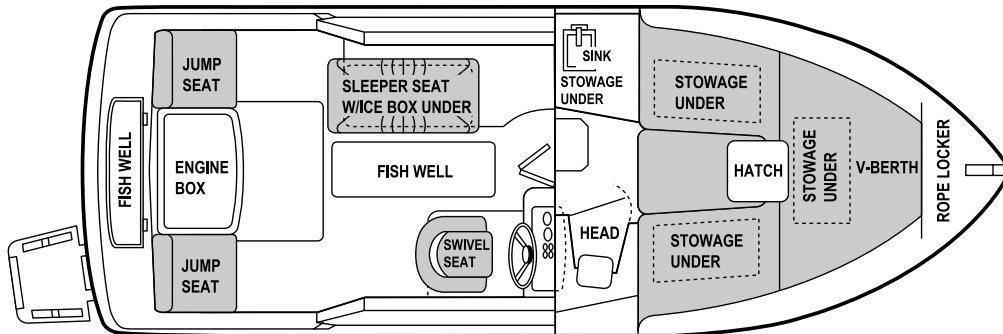

Overall Length	Bridge Clearance	Beam	Maximum Draft	Fuel Tank Capacity (gal)	Water Tank Capacity (gal)
22' 3"	6' 6"	8' 1"	2' 10"	55	13

Hull Exterior Hardware

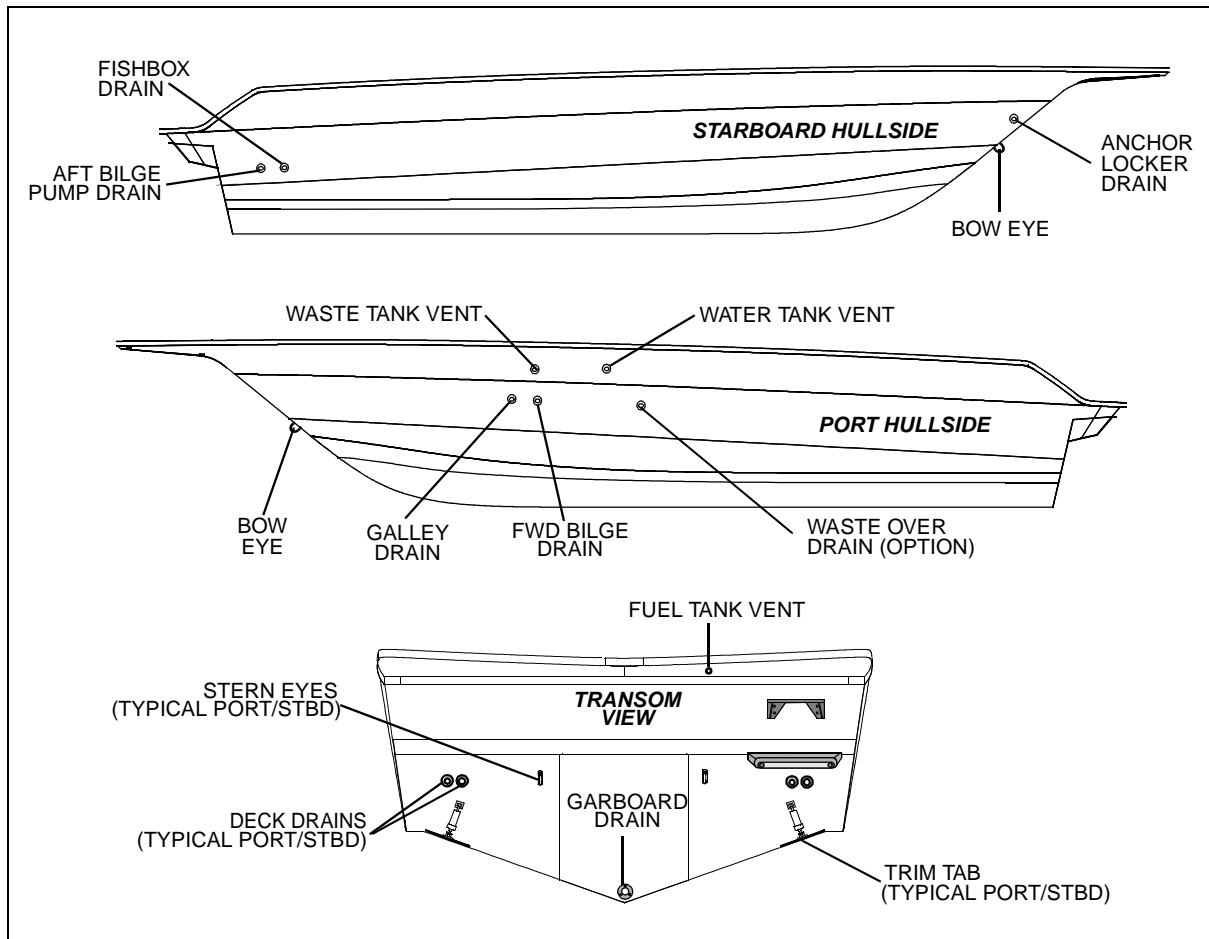

Electrical Routing

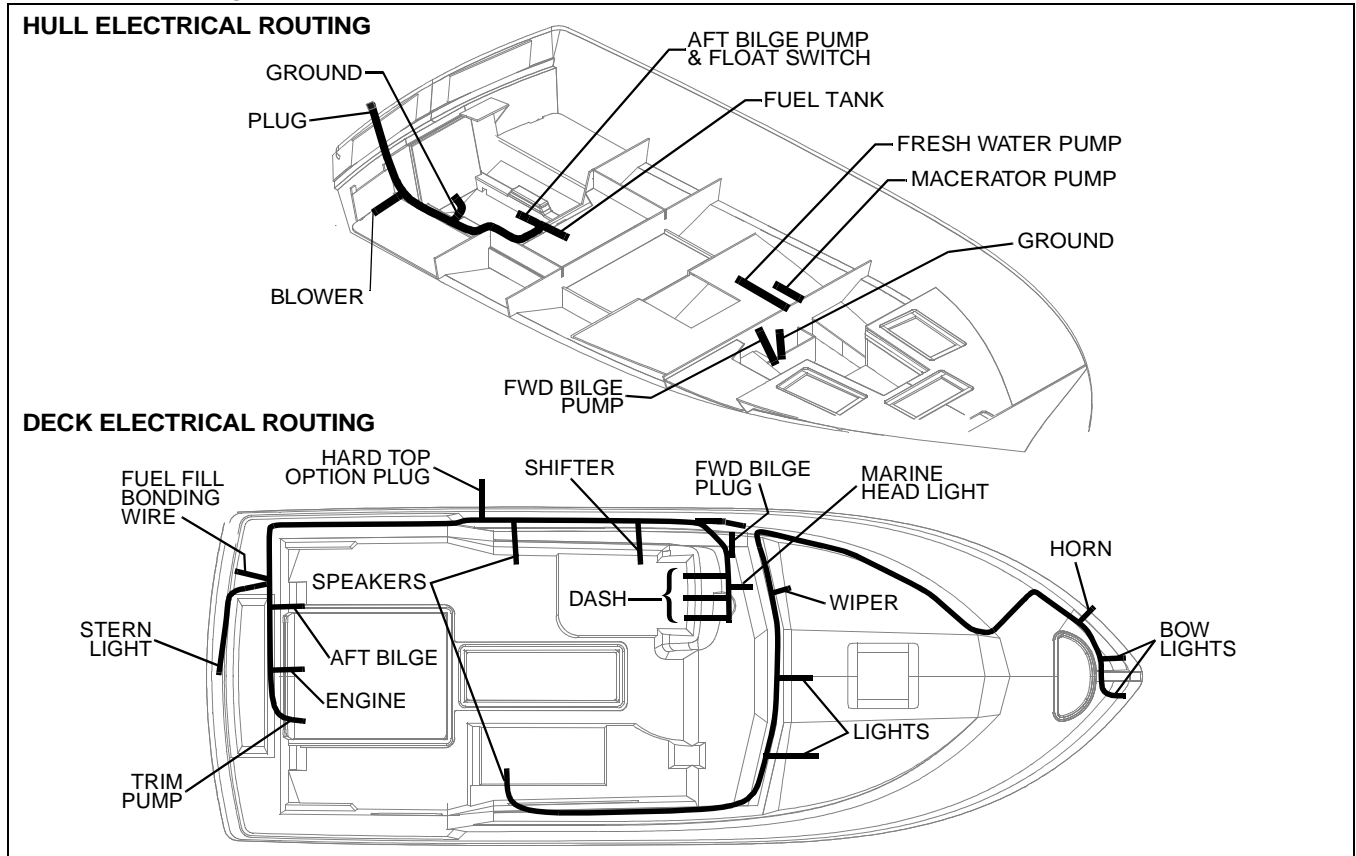

Fresh Water System

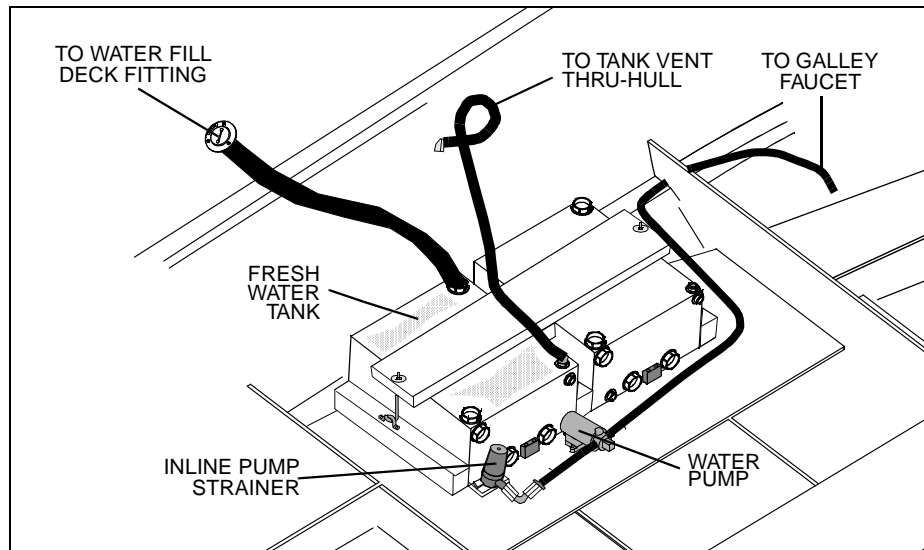

Galley Drain System

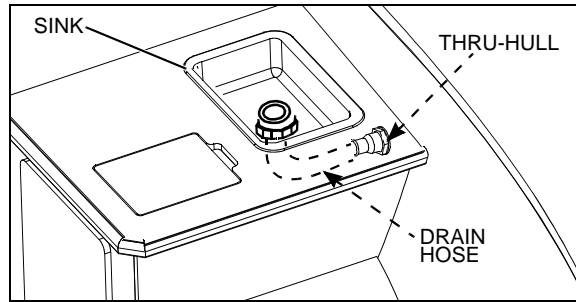

Marine Head (Option)

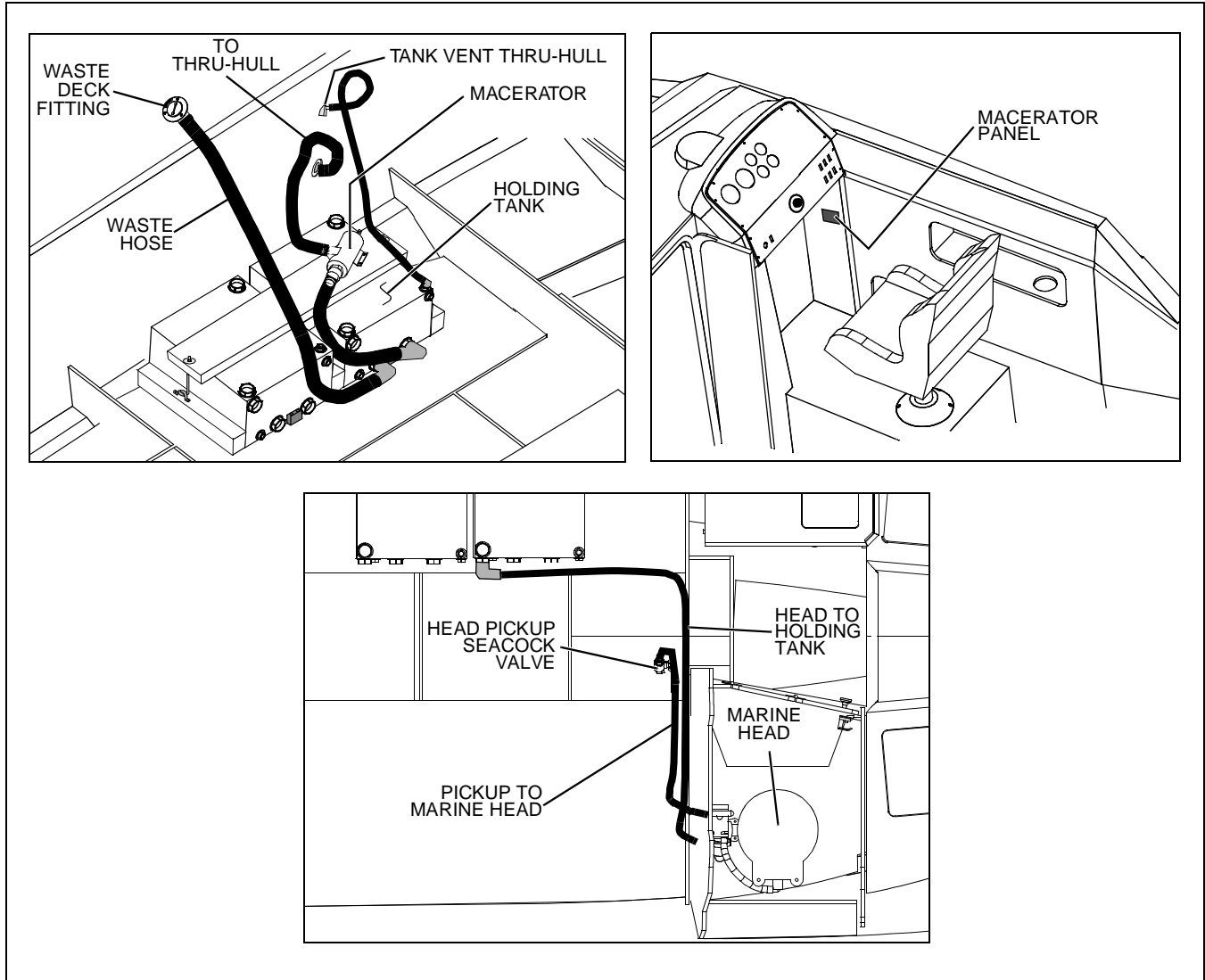

2355 Express (SJ)

Layout View

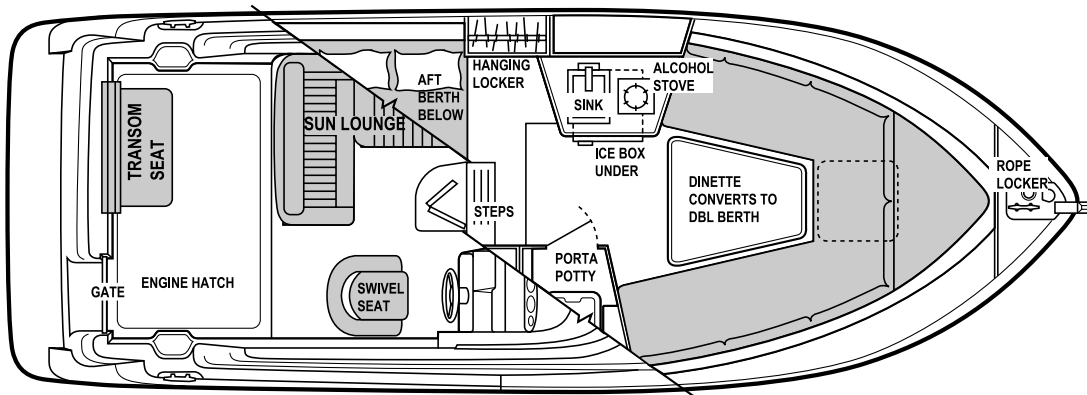

Overall Length	Bridge Clearance	Beam	Maximum Draft	Fuel Tank Capacity (gal)	Water Tank Capacity (gal)
23' 4"	6' 2"	8' 6"	2' 10"	55	13

Hull Exterior Hardware

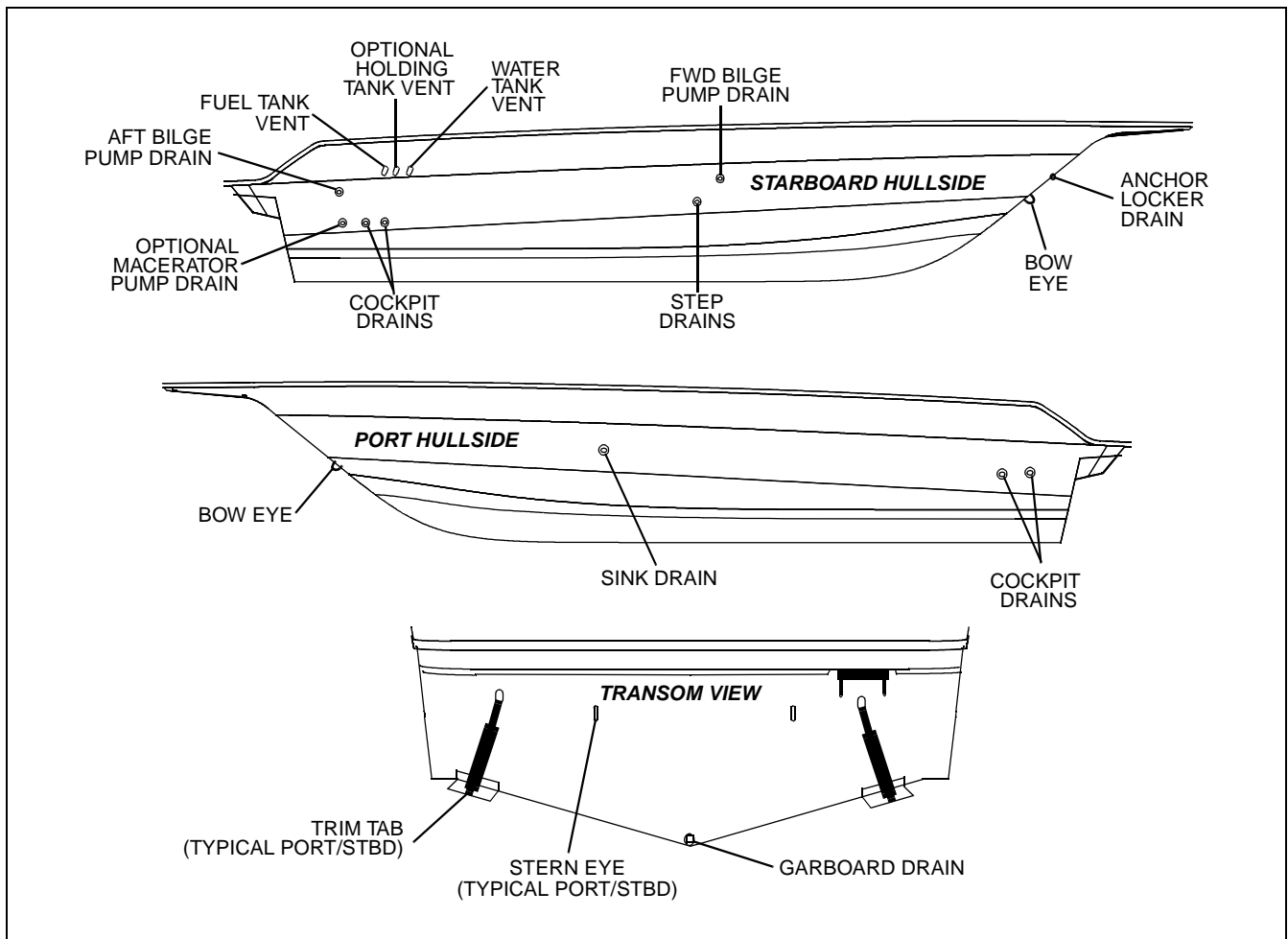

Electrical Routing

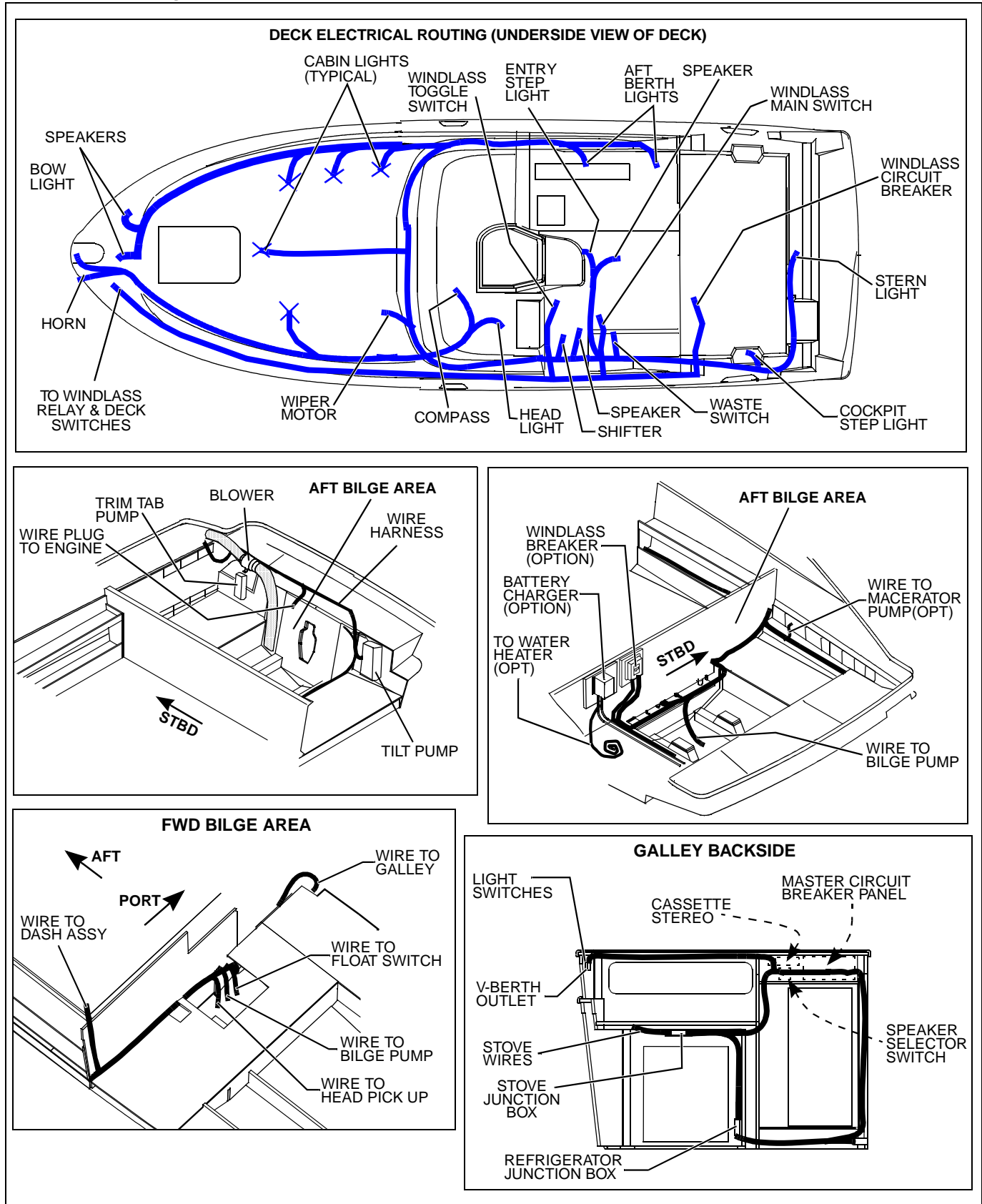

Fresh Water System Option

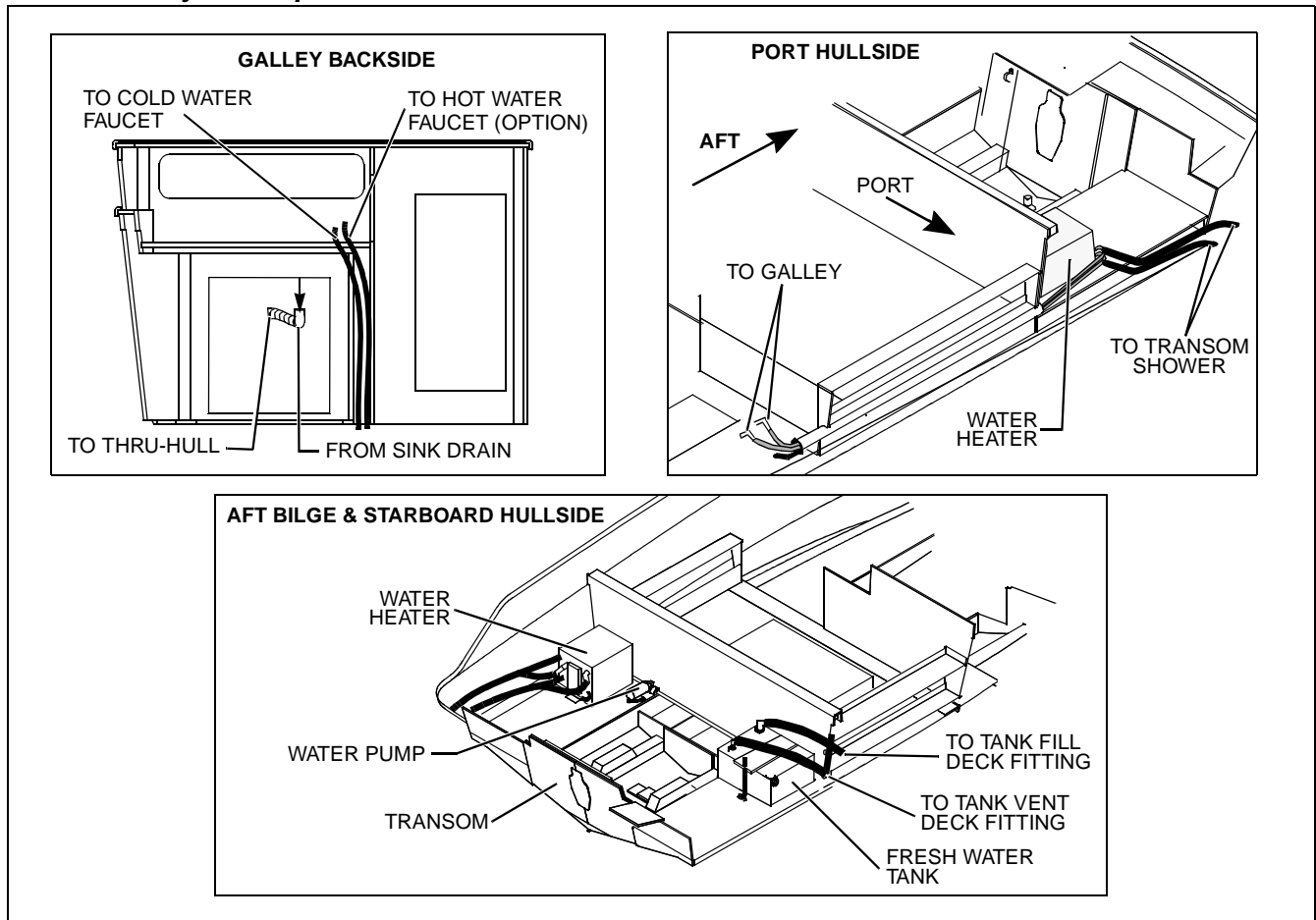

Waste System Option

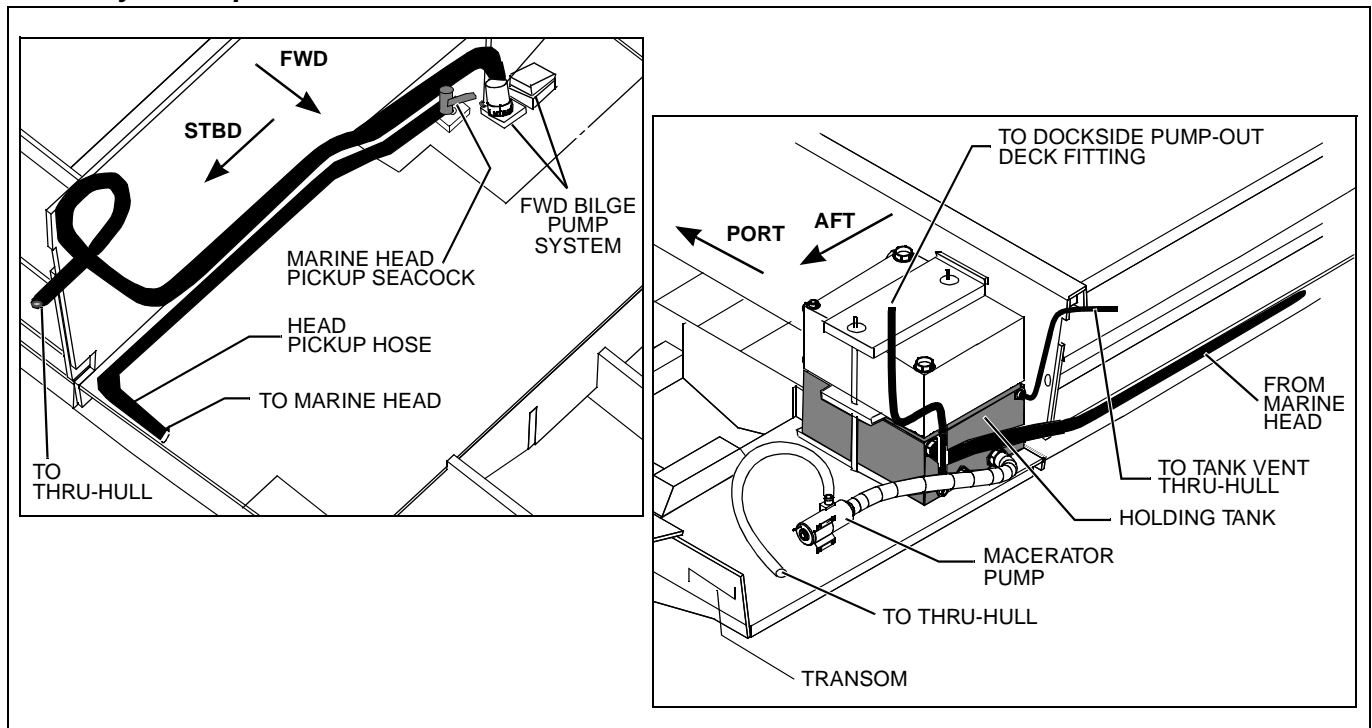

Air Conditioning Option

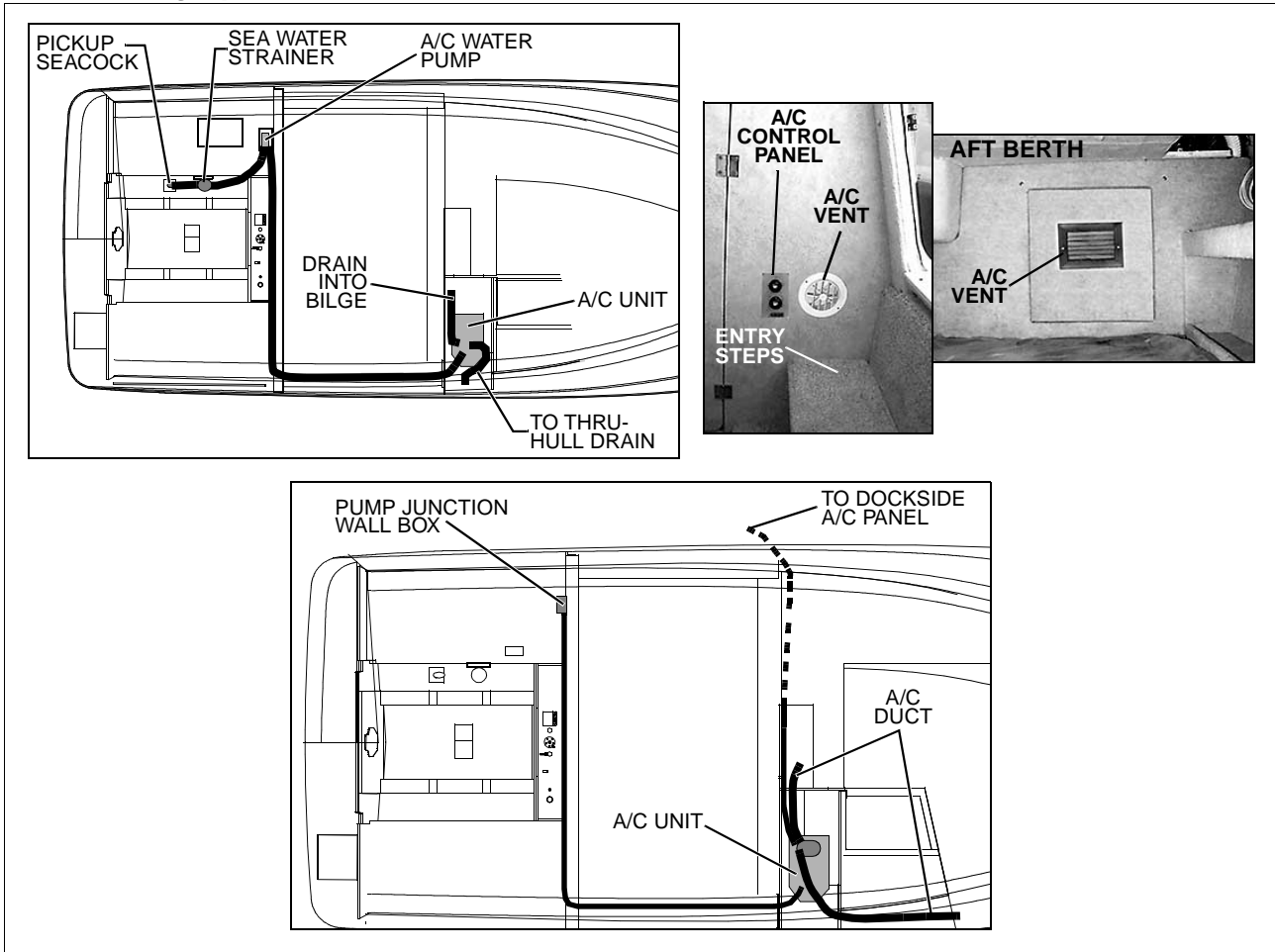

2452 Express (CD)

Layout View

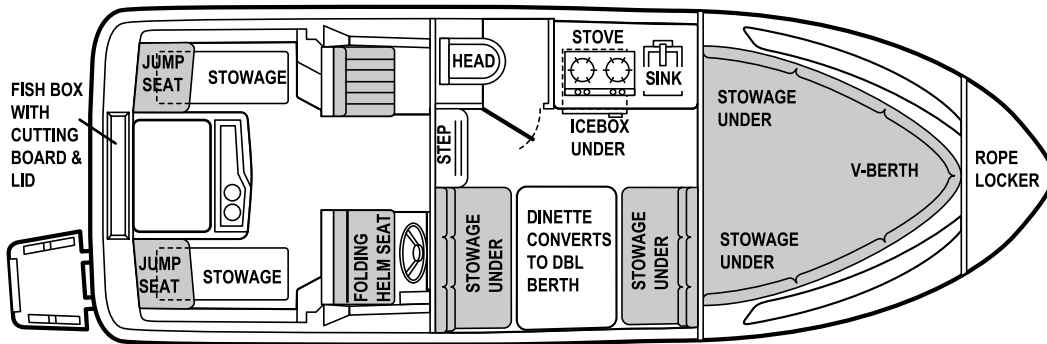

Overall Length	Bridge Clearance	Beam	Maximum Draft	Fuel Tank Capacity (gal)	Water Tank Capacity (gal)	Holding Tank Capacity (gal)
23'5"	8'4"	8'4"	2'11"	78	20	78

Hull Exterior Hardware

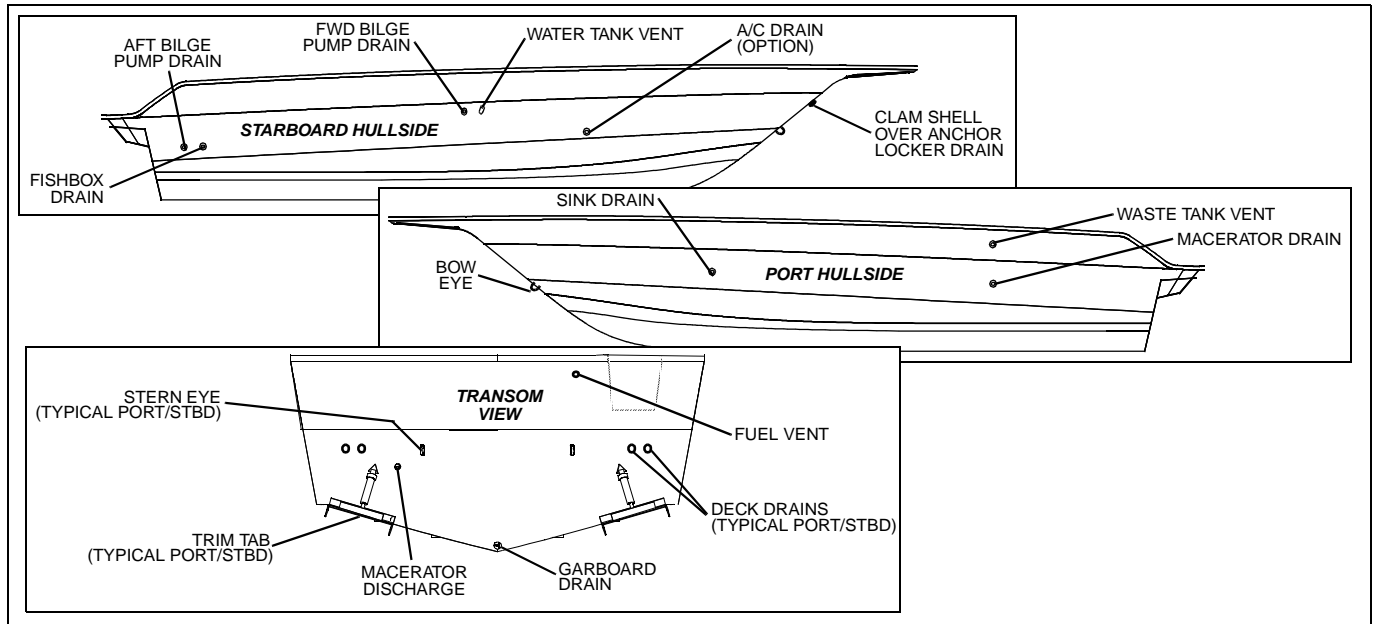

Air Conditioning Option

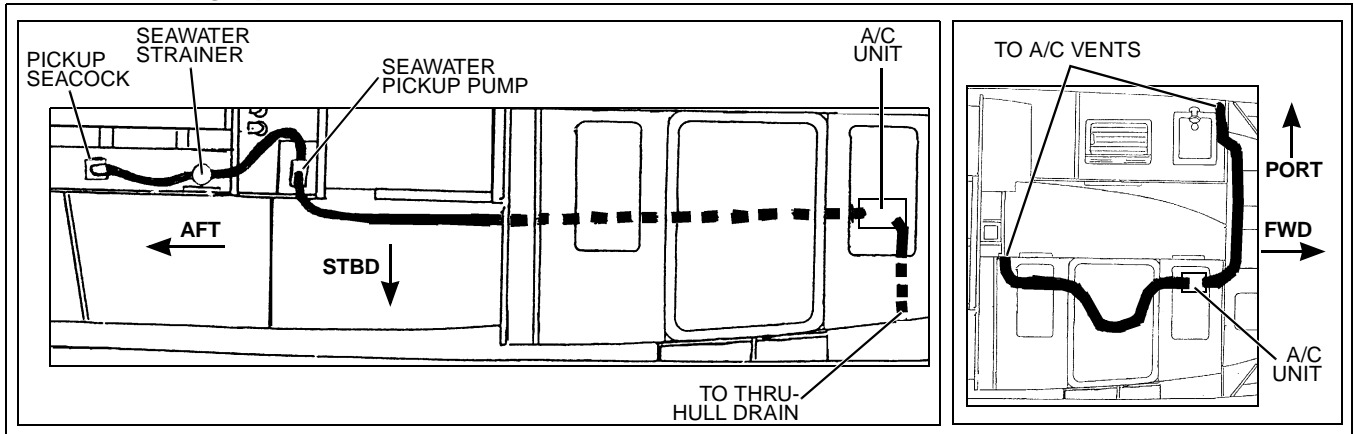

Electrical Routing

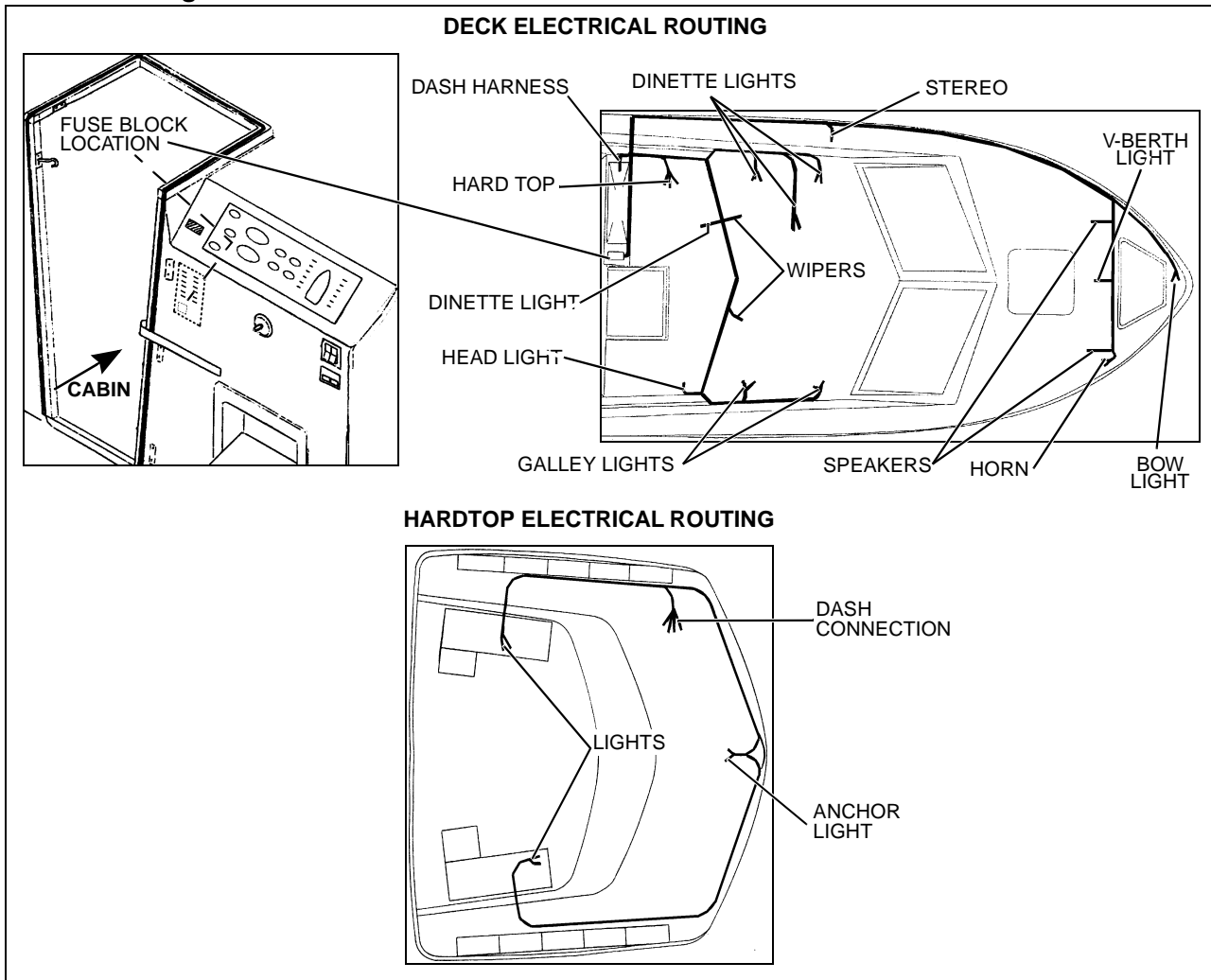

Macerator Option

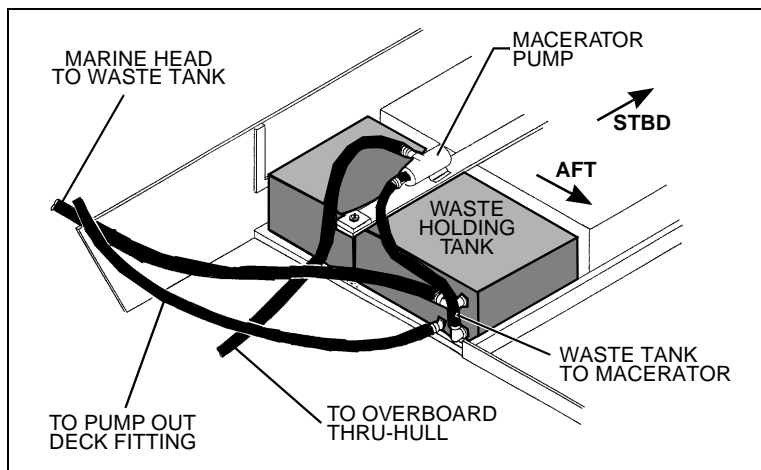

Fresh Water/Marine Head System

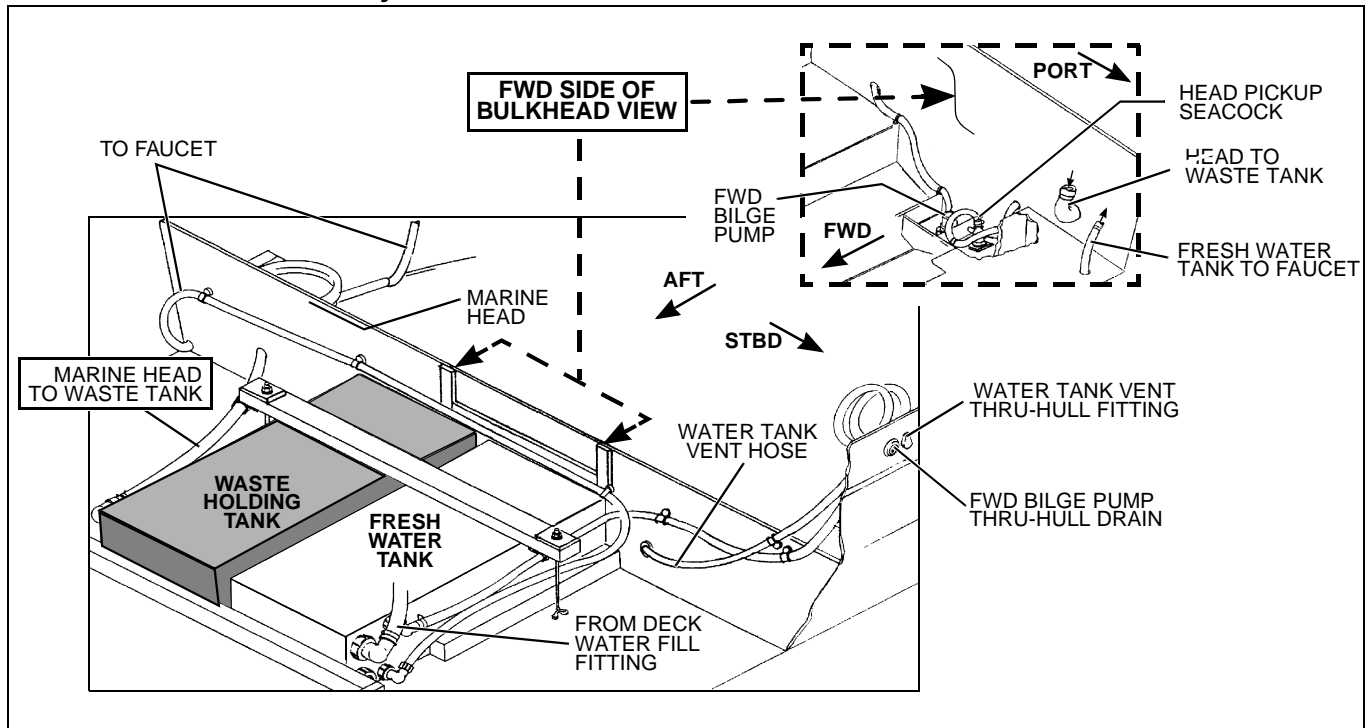

Hot Water System Option

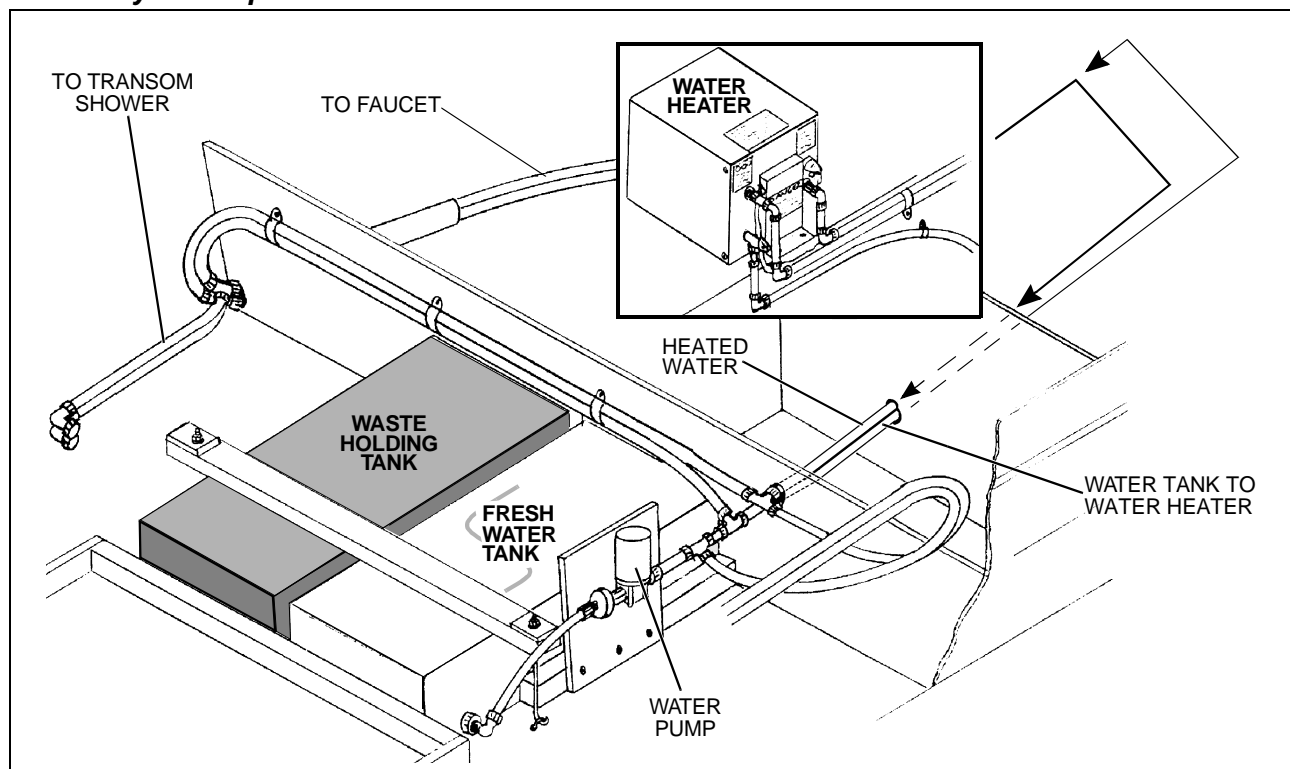

2655 Sunbridge (SB)

Layout View

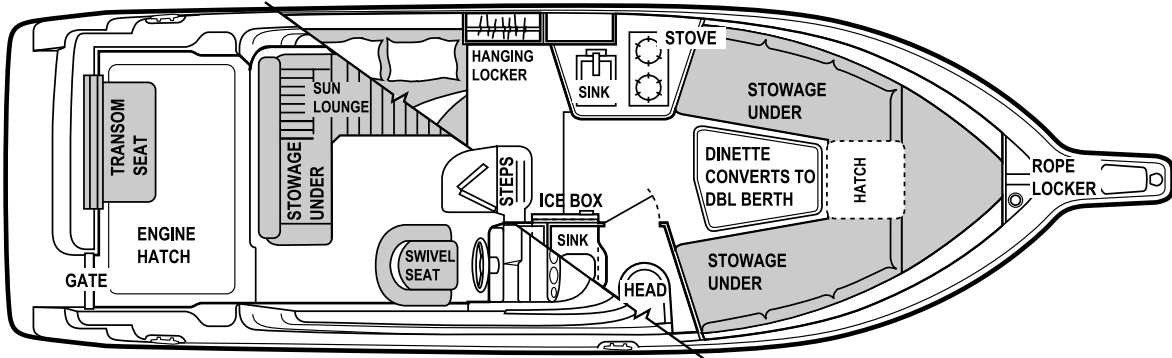

Overall Length	Bridge Clearance	Beam	Maximum Draft	Fuel Tank Capacity (gal)	Water Tank Capacity (gal)	Holding Tank Capacity (gal)
27' 9"	7' 0"	8' 5"	2' 10"	70	27	13

Hull Exterior Hardware

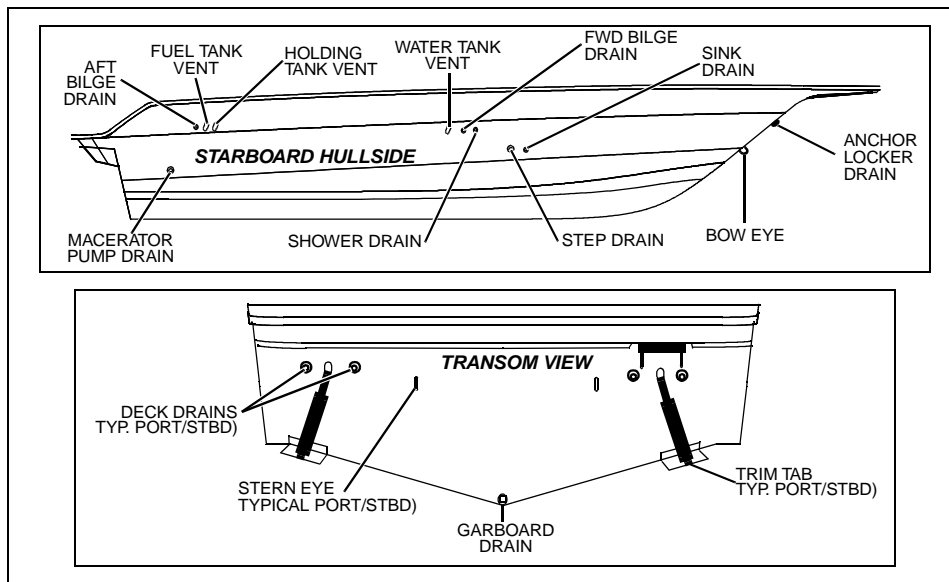

Hull Electrical Routing

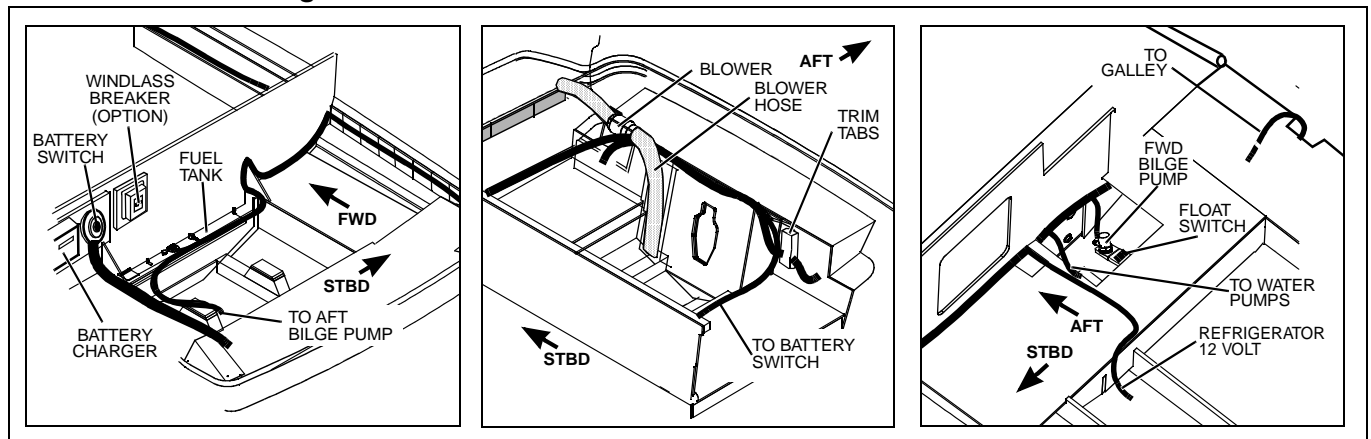

Deck Electrical Routing

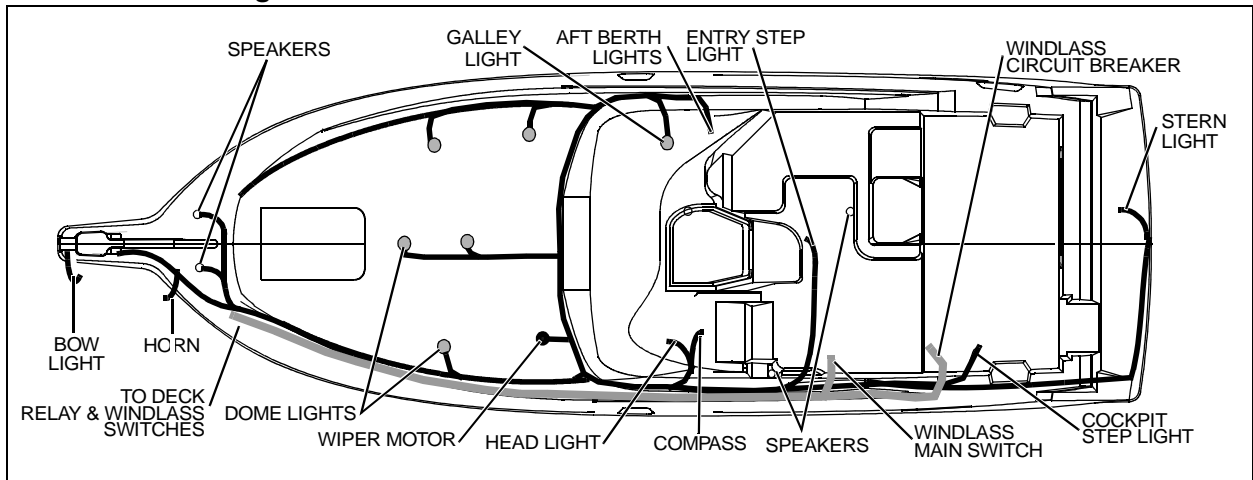

Galley Details

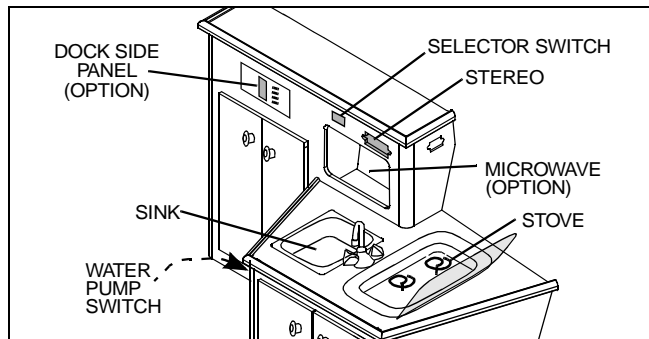

Marine Head Holding Tank

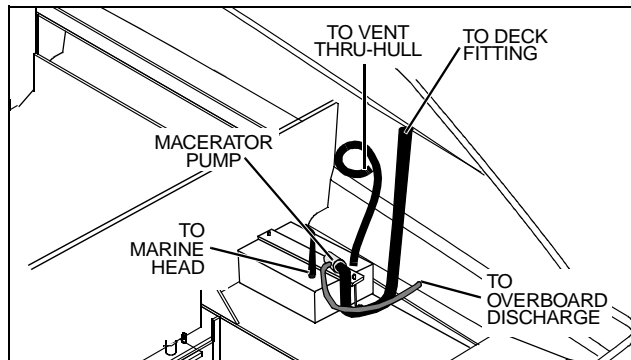

Deck Fittings and Drains

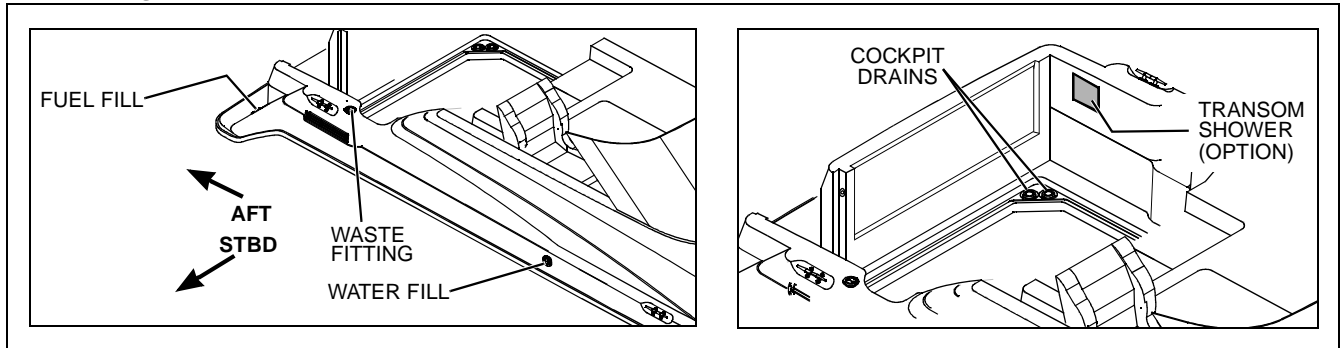

2855 Sunbridge (ST)

Layout View

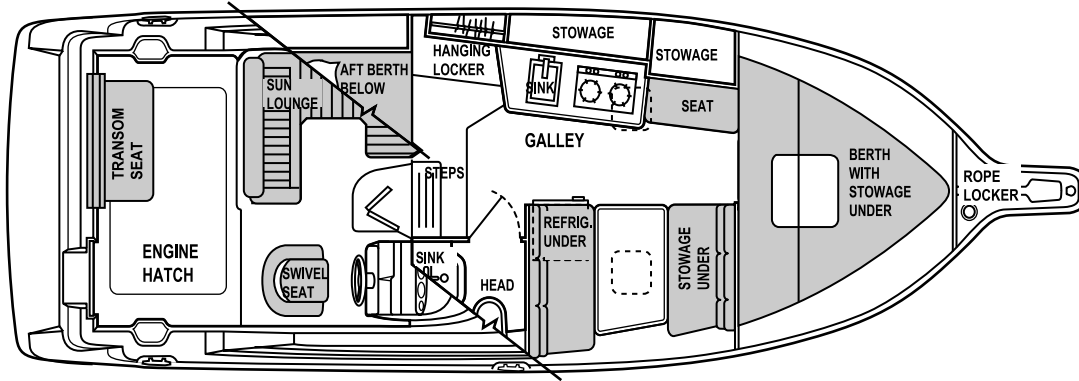

Overall Length	Bridge Clearance	Beam	Maximum Draft	Fuel Tank Capacity (gal)	Water Tank Capacity (gal)	Holding Tank Capacity (gal)
30' 3"	7' 5"	9' 7"	3' 1"	109	33	13

Hull Exterior Hardware

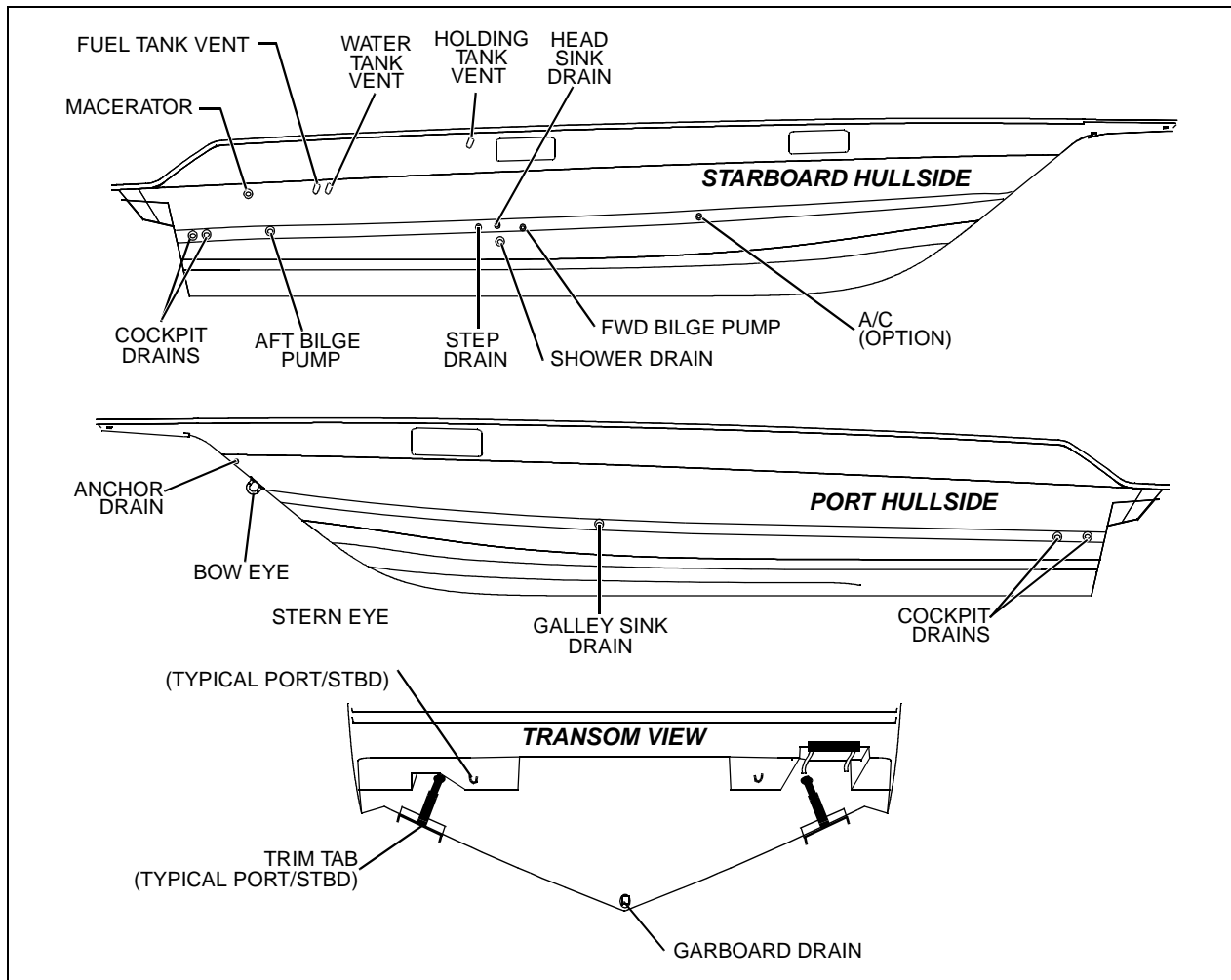

Hull Electrical Routing

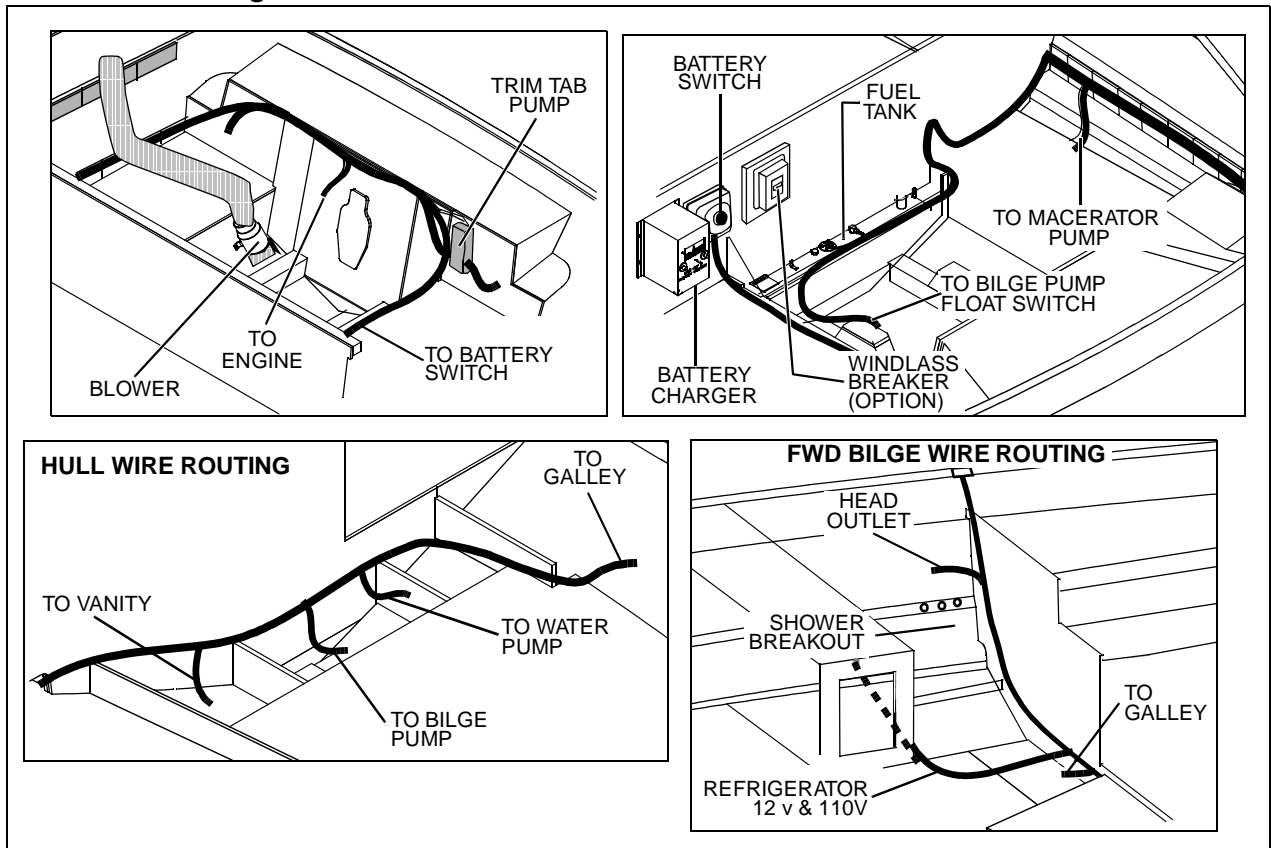

Deck Electrical System

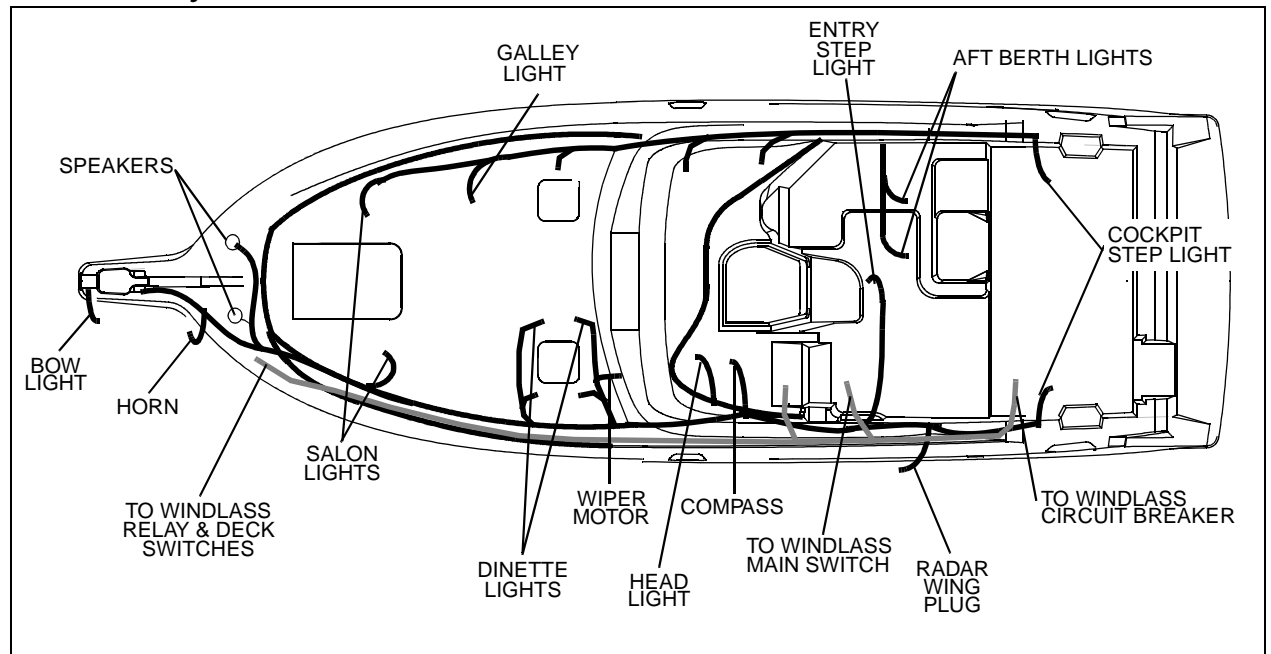

Helm Area

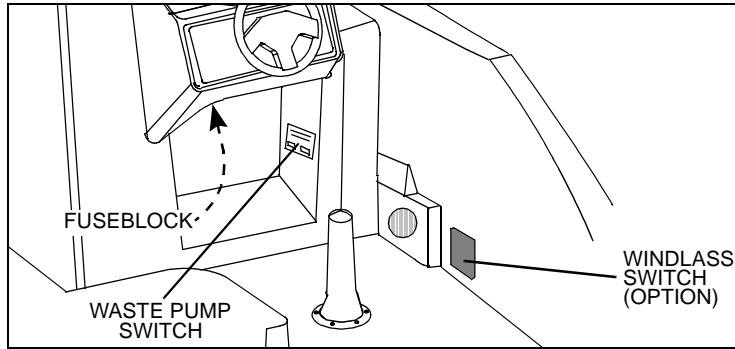

Air Conditioning System

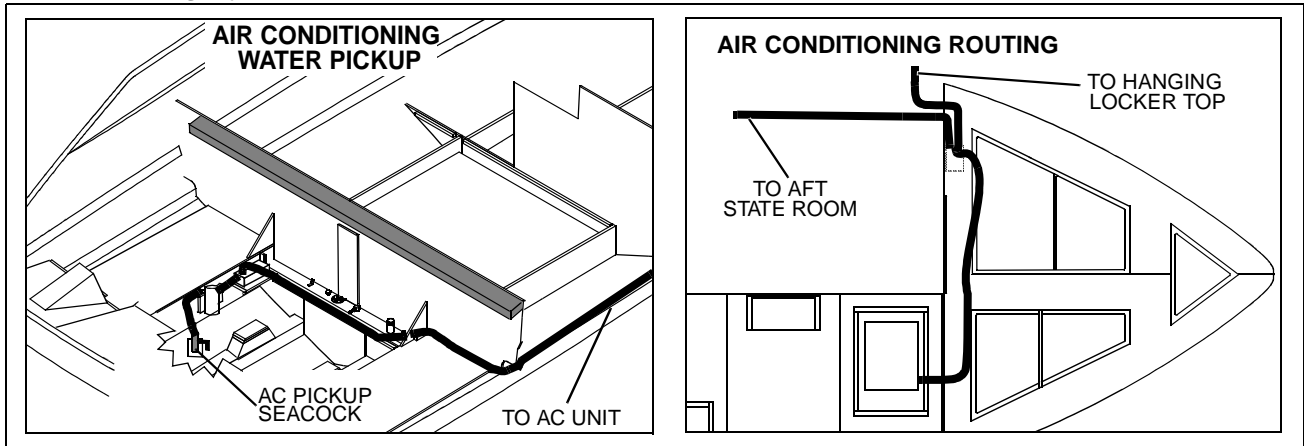

Freshwater System

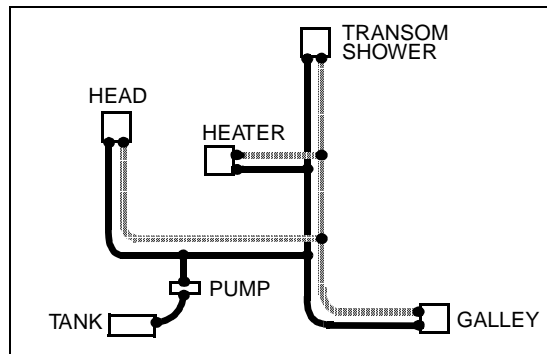

Marine Head System and Waste Fitting

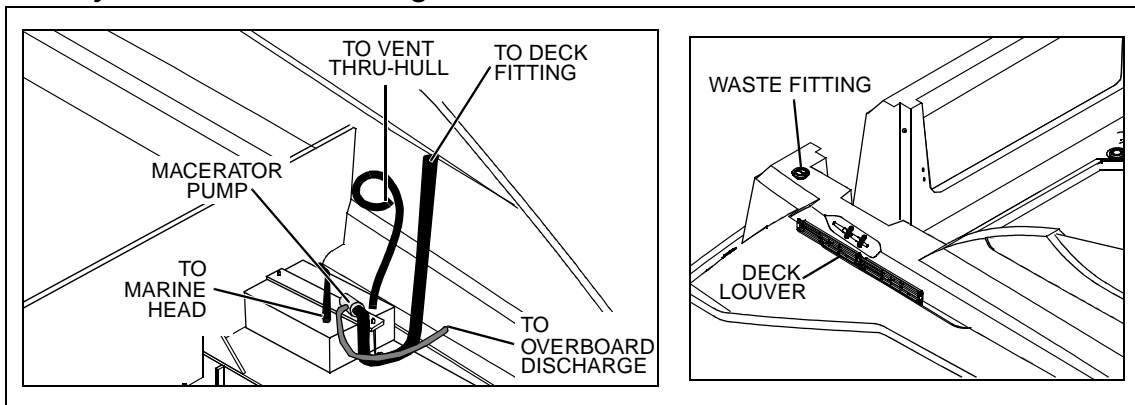

2858 Command Bridge (EC)

Layout View

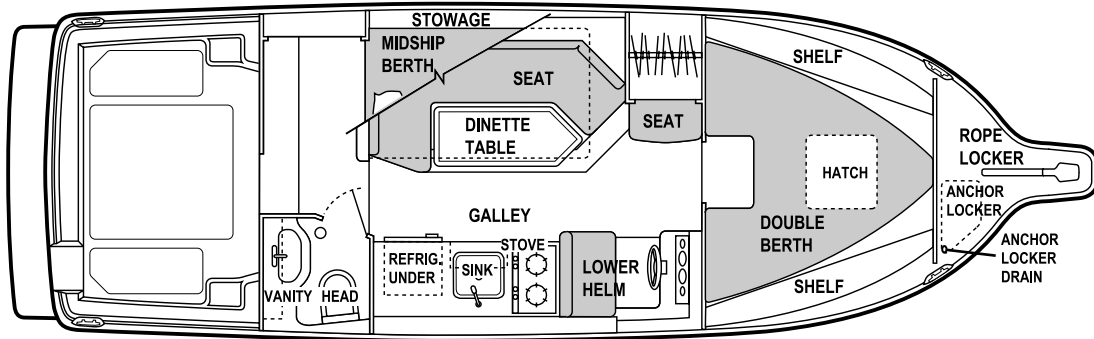

Overall Length	Bridge Clearance	Beam	Maximum Draft	Fuel Tank Capacity (gal)	Water Tank Capacity (gal)	Holding Tank Capacity (gal)
30' 6"	9' 3"	9' 10"	3' 6"	113	34	26

Hull Fittings and Hardware

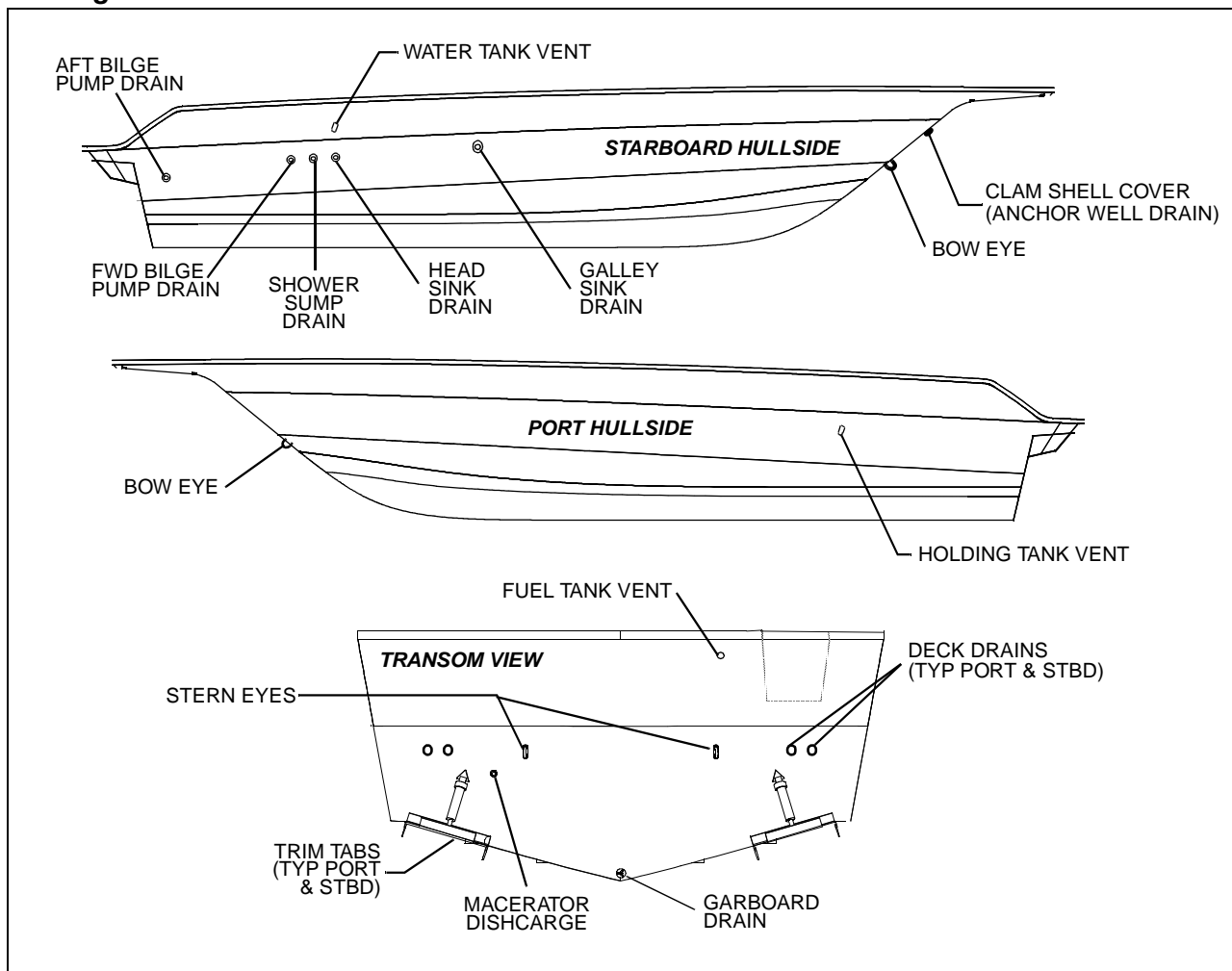

12 Volt DC Wire Routing

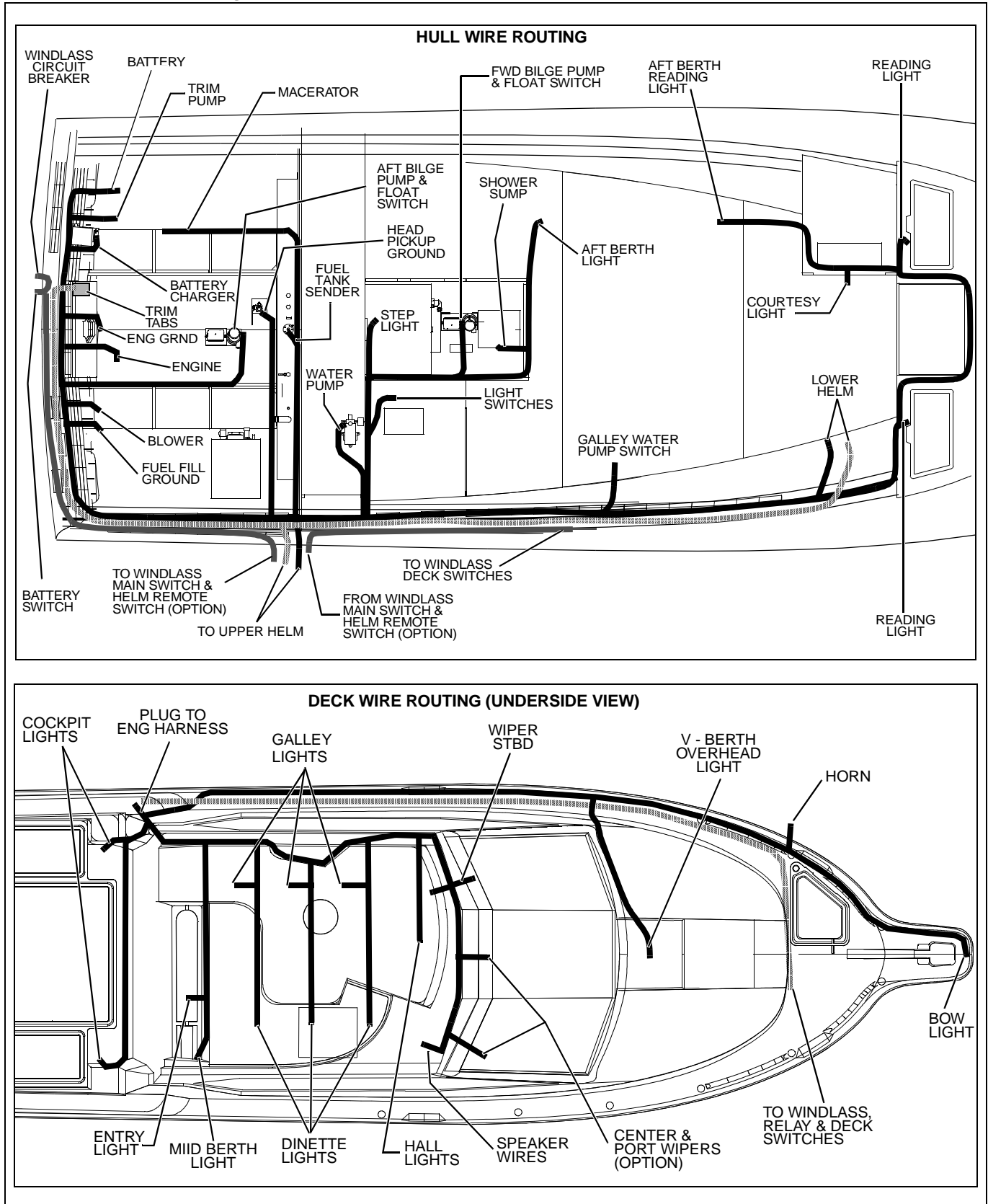

110 Volt AC Wire Routing (Romex)

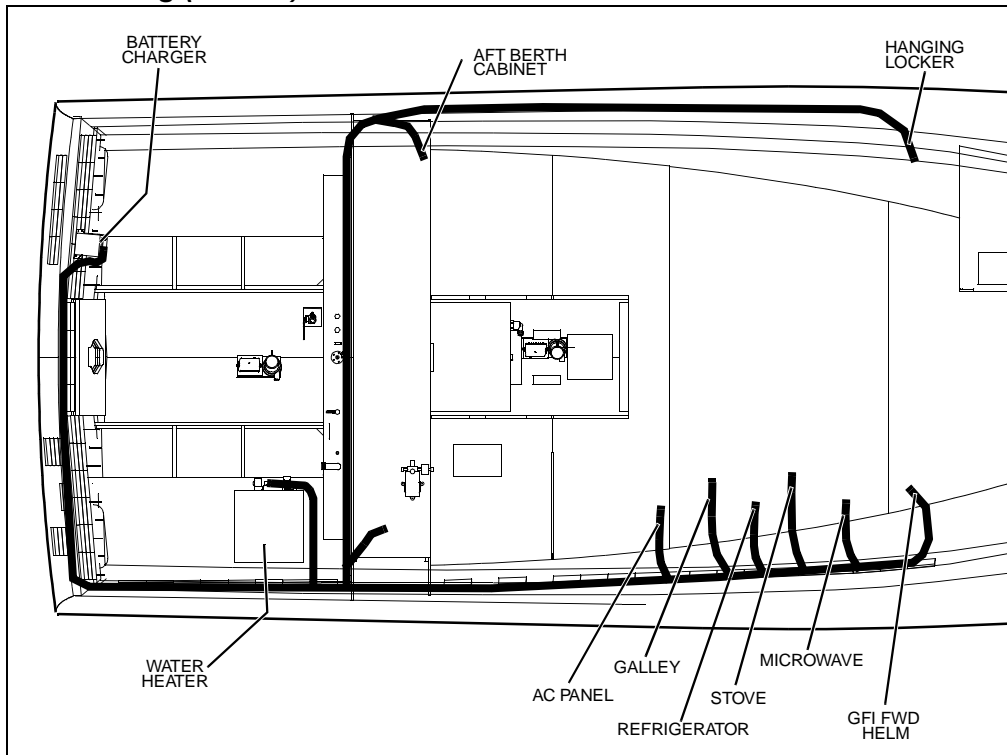

Fresh Water System

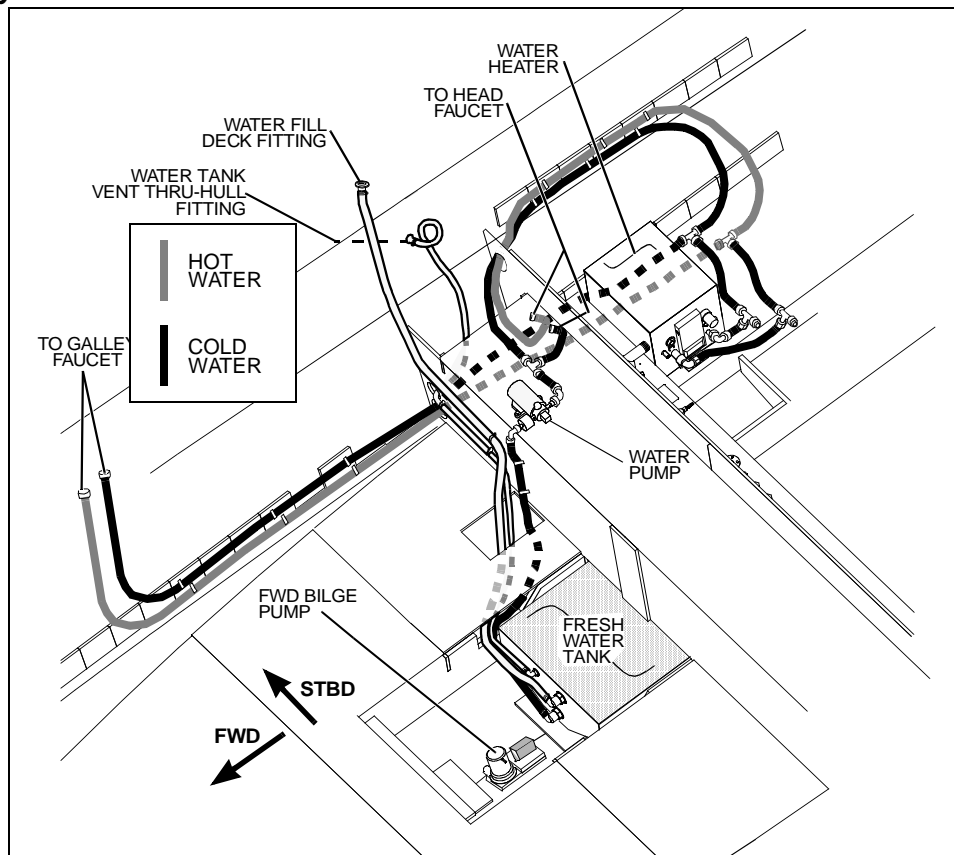

A/C Hose Routing (OAB)

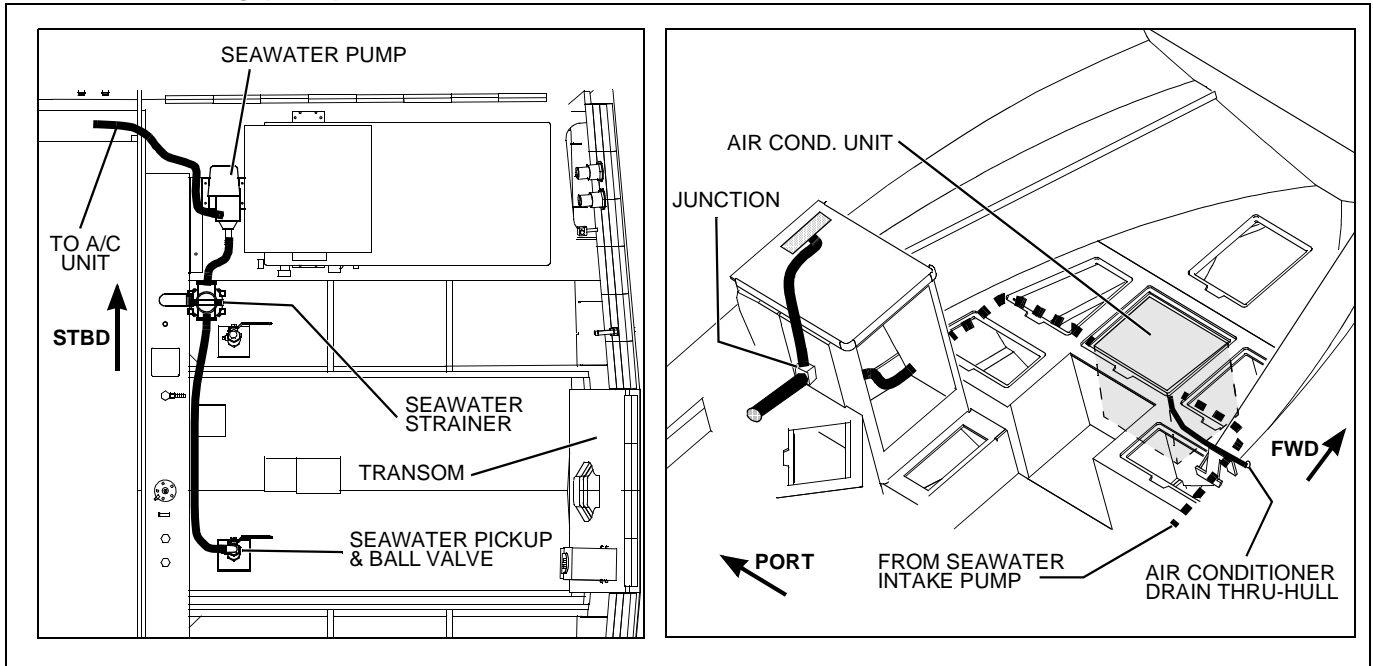

Shower Drain System

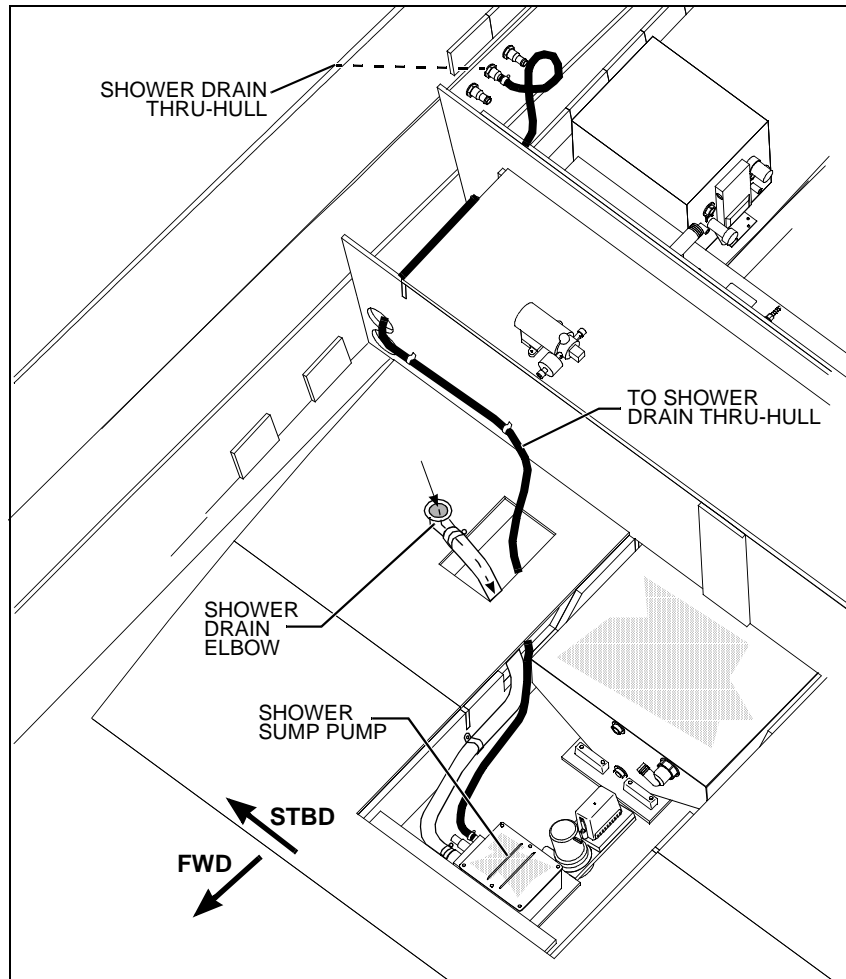

Marine Head System

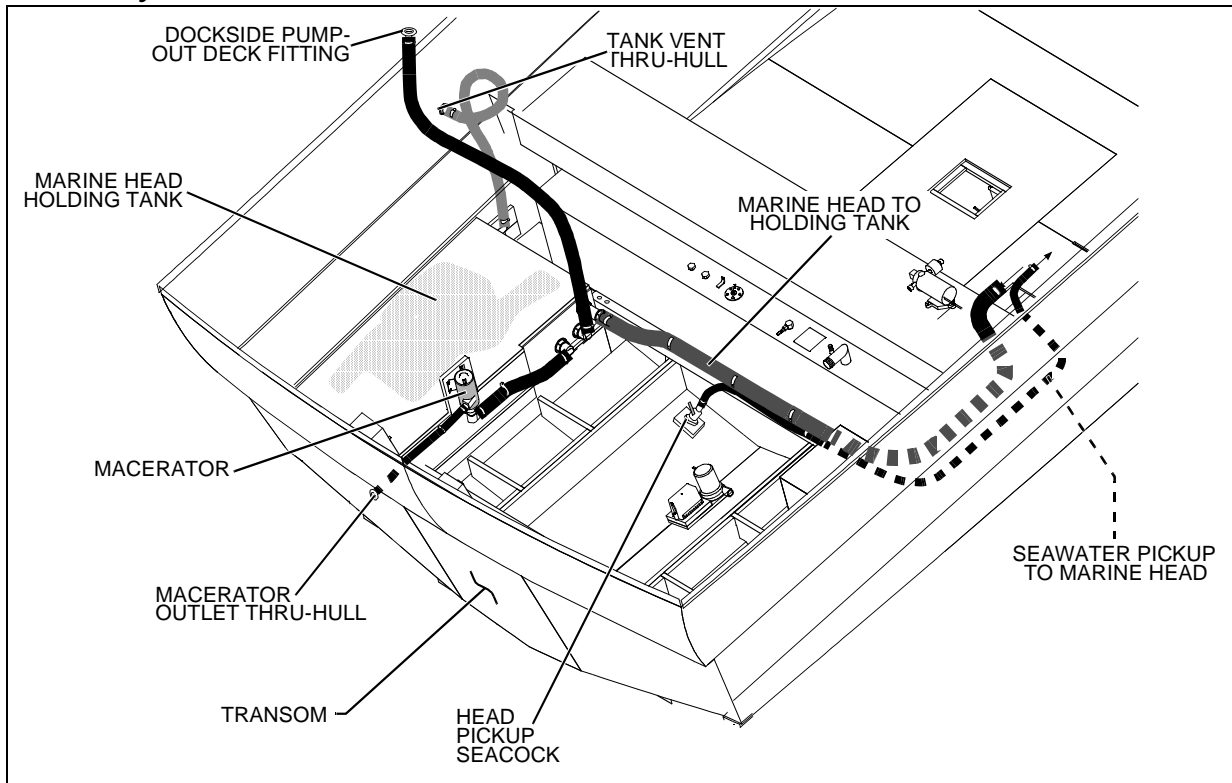

Seawater Pickup System (Diesel Engine Option)

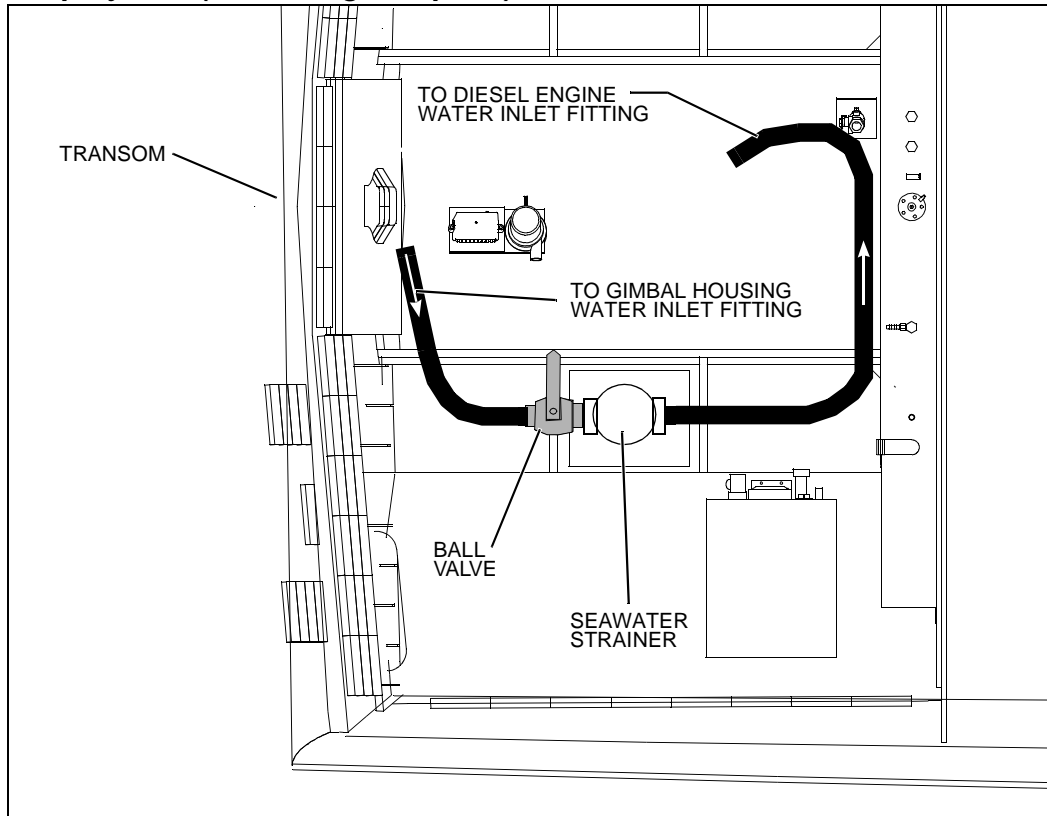

2859 Express (SC)

Layout View

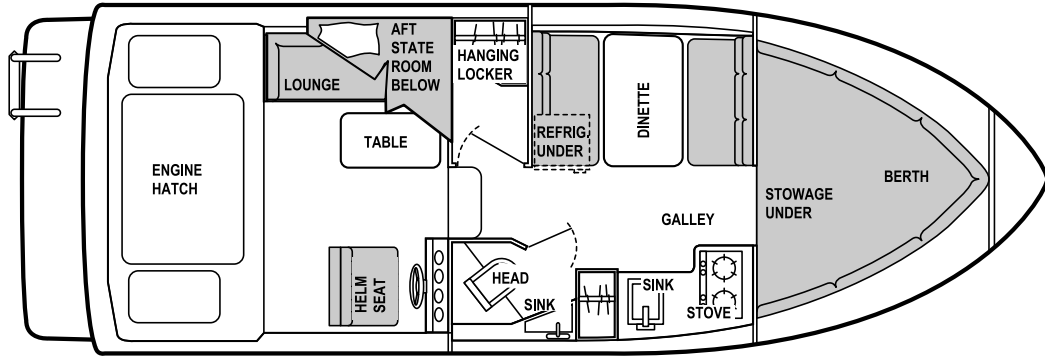

Overall Length	Bridge Clearance	Beam	Maximum Draft	Fuel Capacity (gal)	Water Tank Capacity (gal)	Holding Tank Capacity (gal)
27' 8"	9' 1"	9' 9"	3' 0"	102	36	30

Hull Exterior Hardware

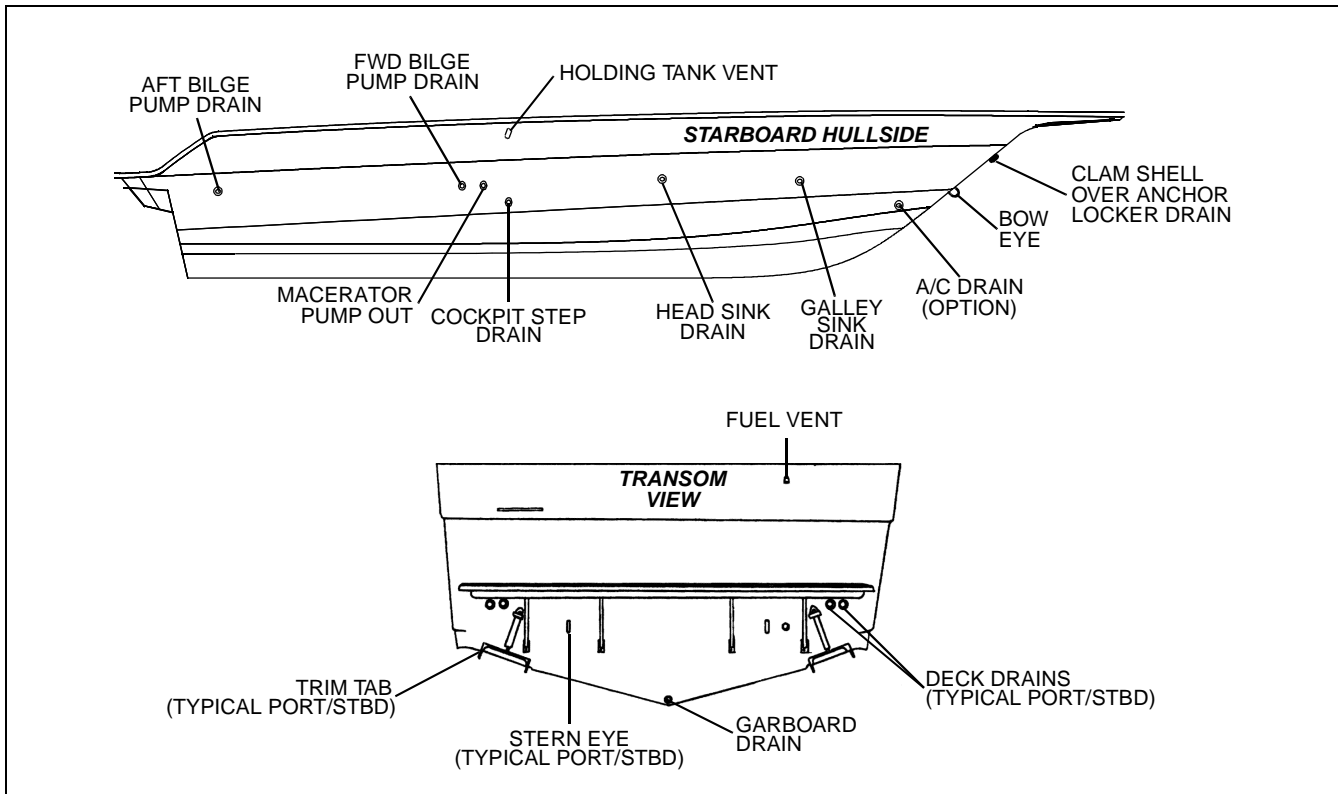

Marine Head System

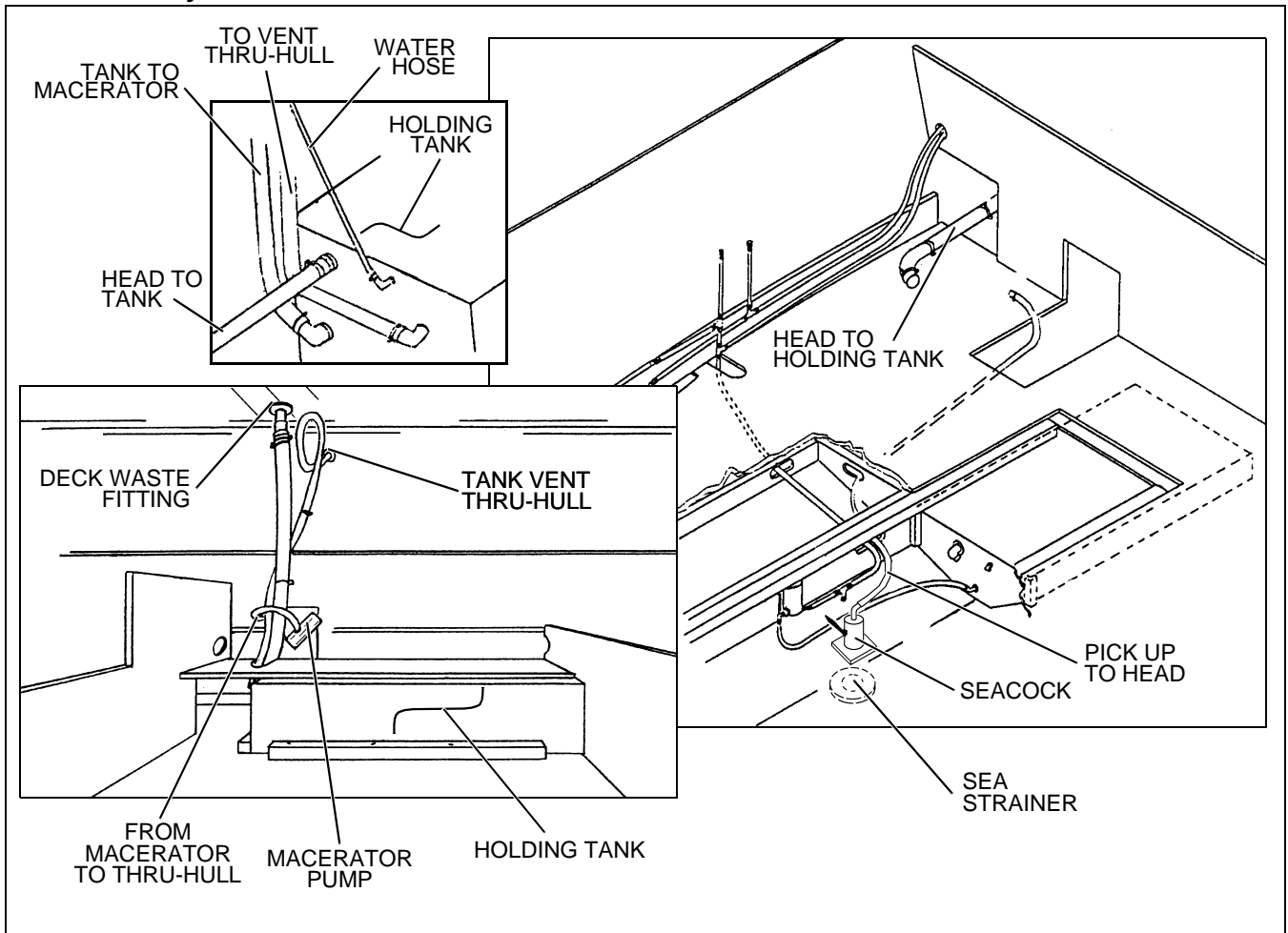

Seawater Pickup System (Diesel Engine Option)

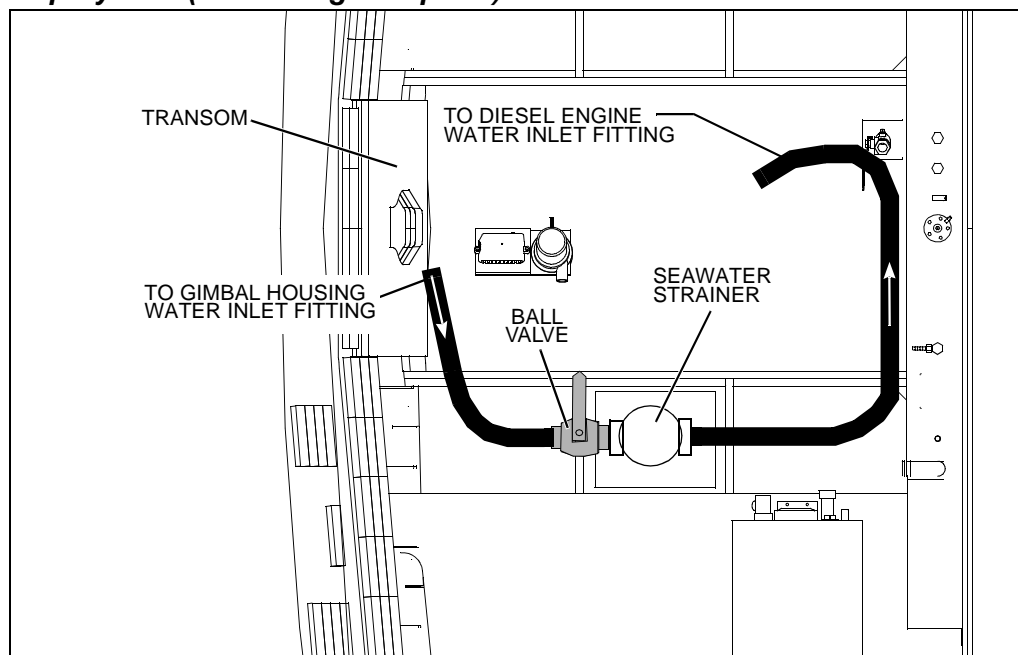

Fresh Water System

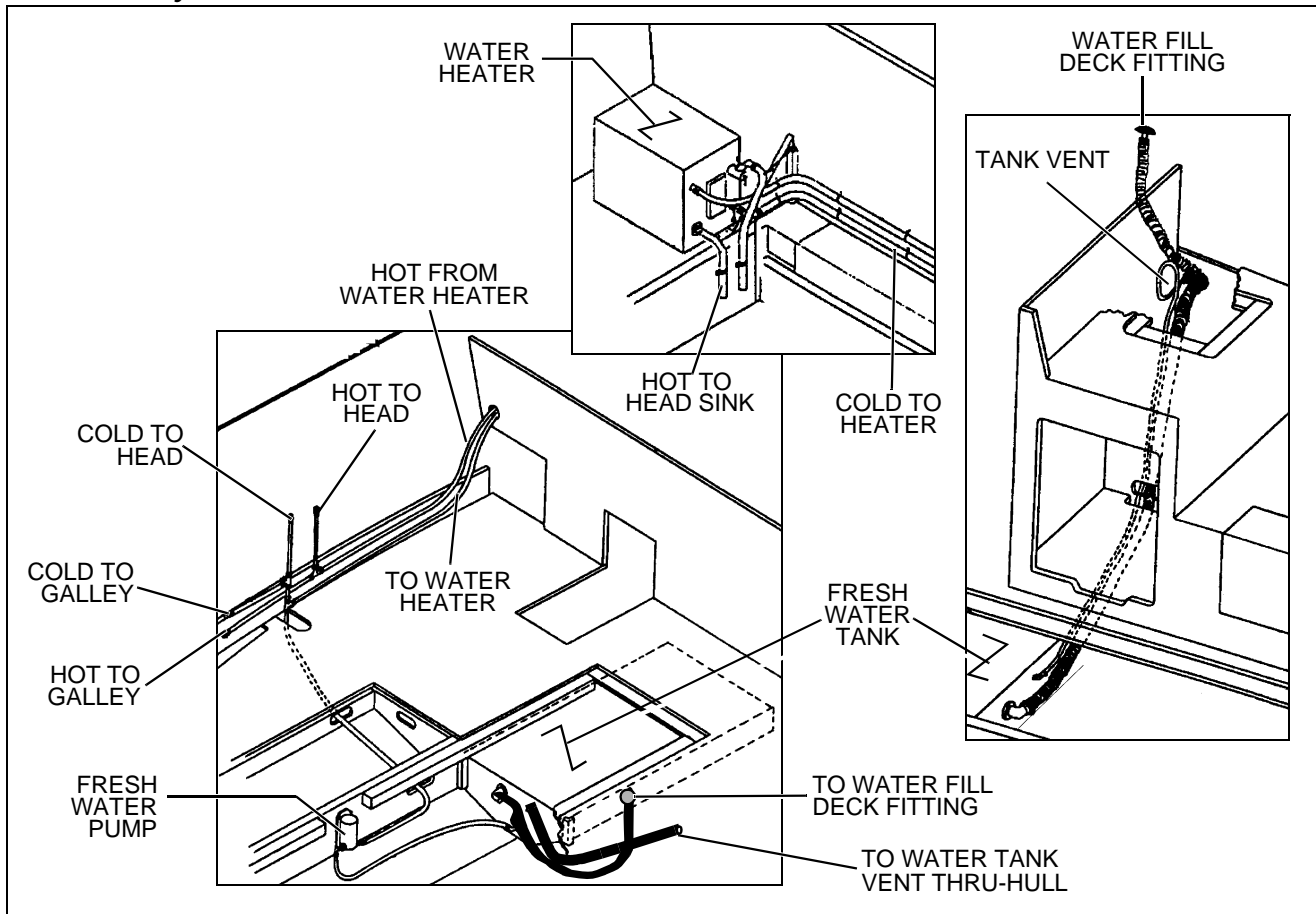

Cabin Heat

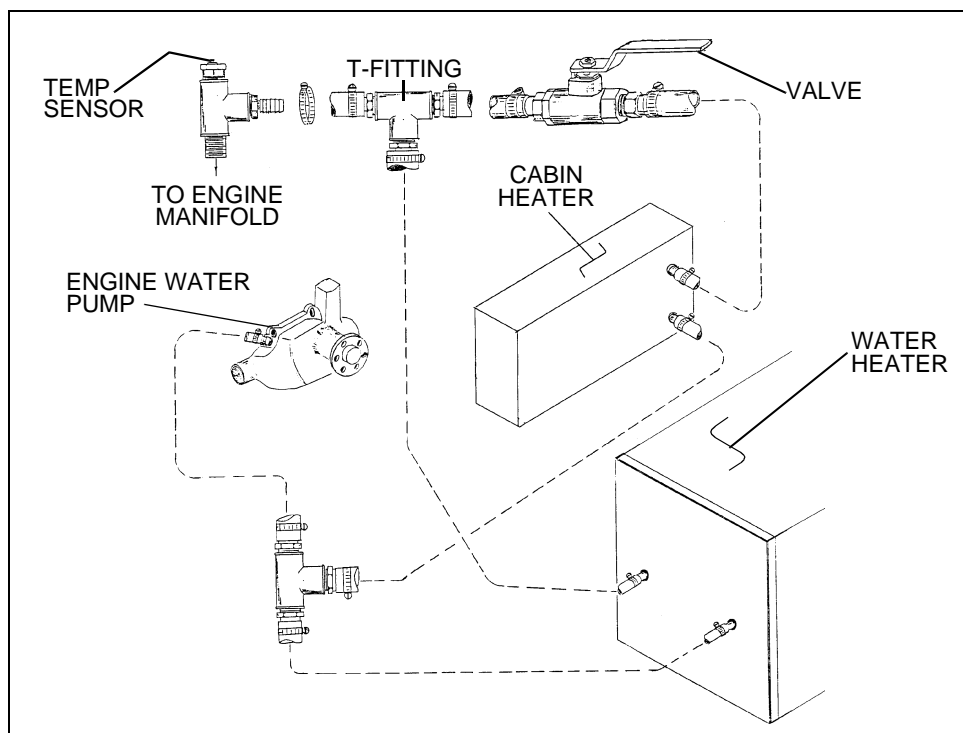

Shower Drain System

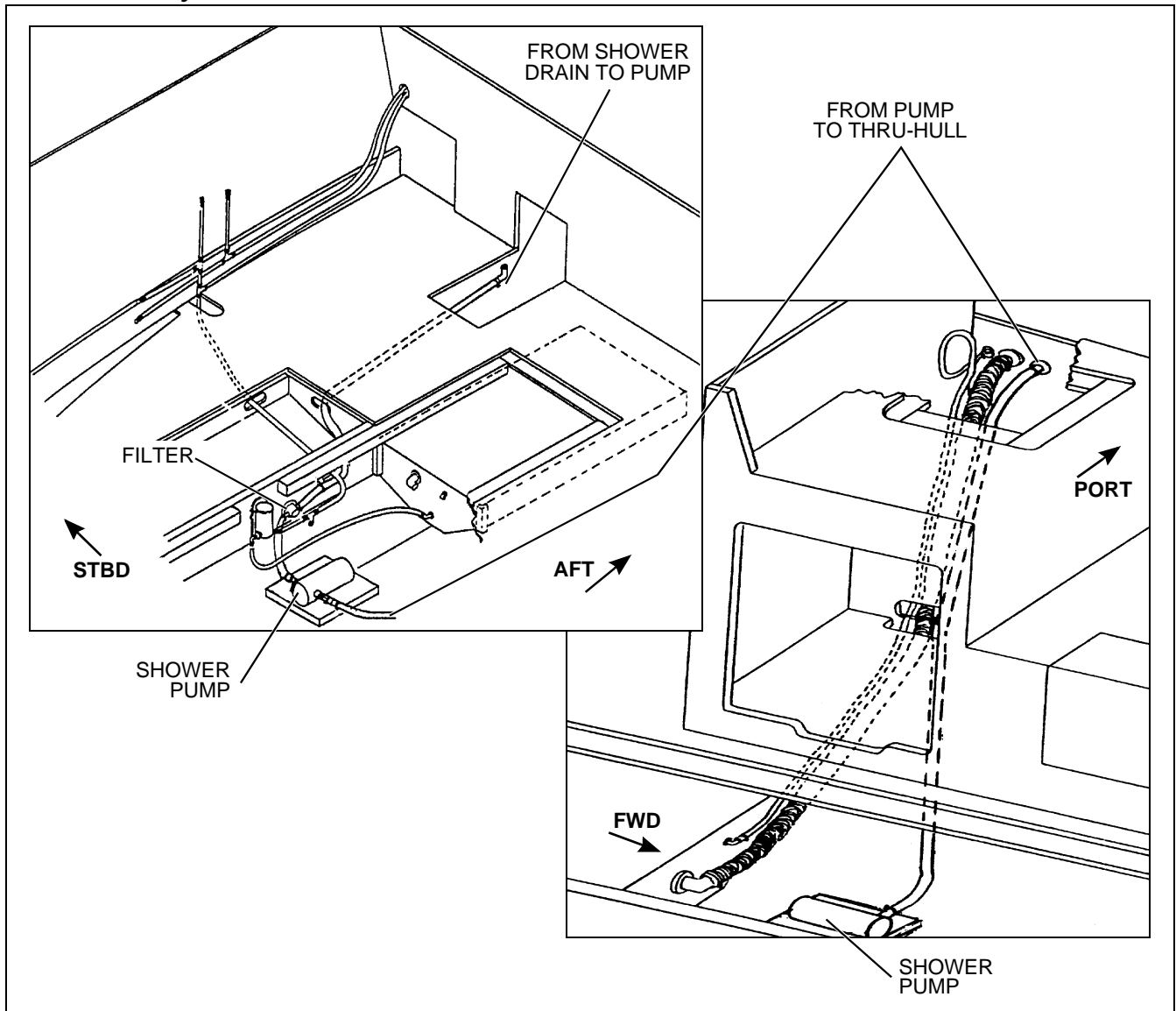

Galley Sink Drain

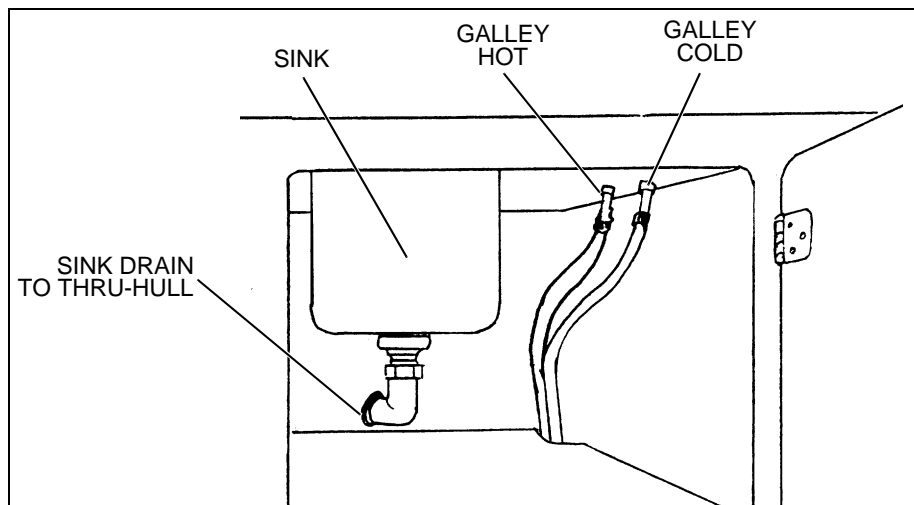

Deck 12 Volt DC Wire Routing

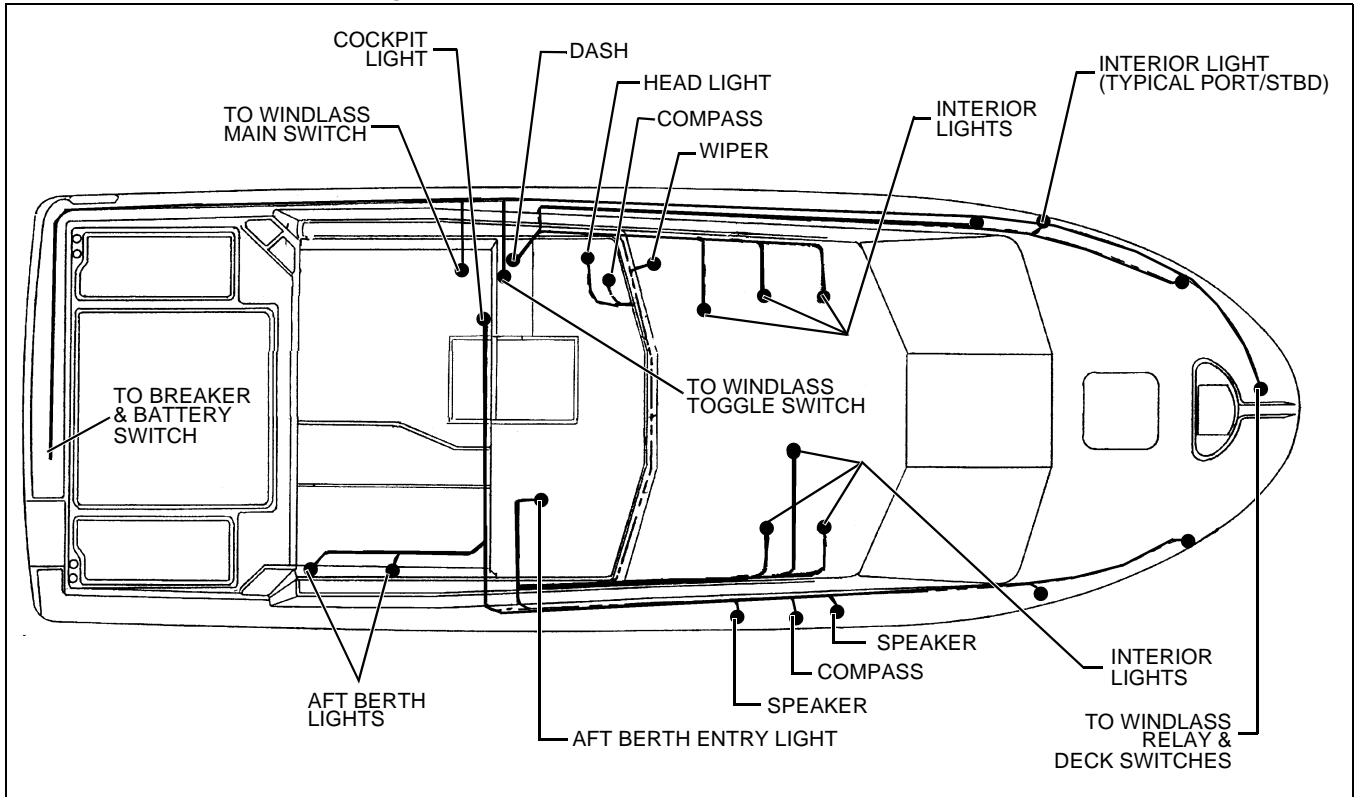

Hull 12 Volt DC Wire Harness

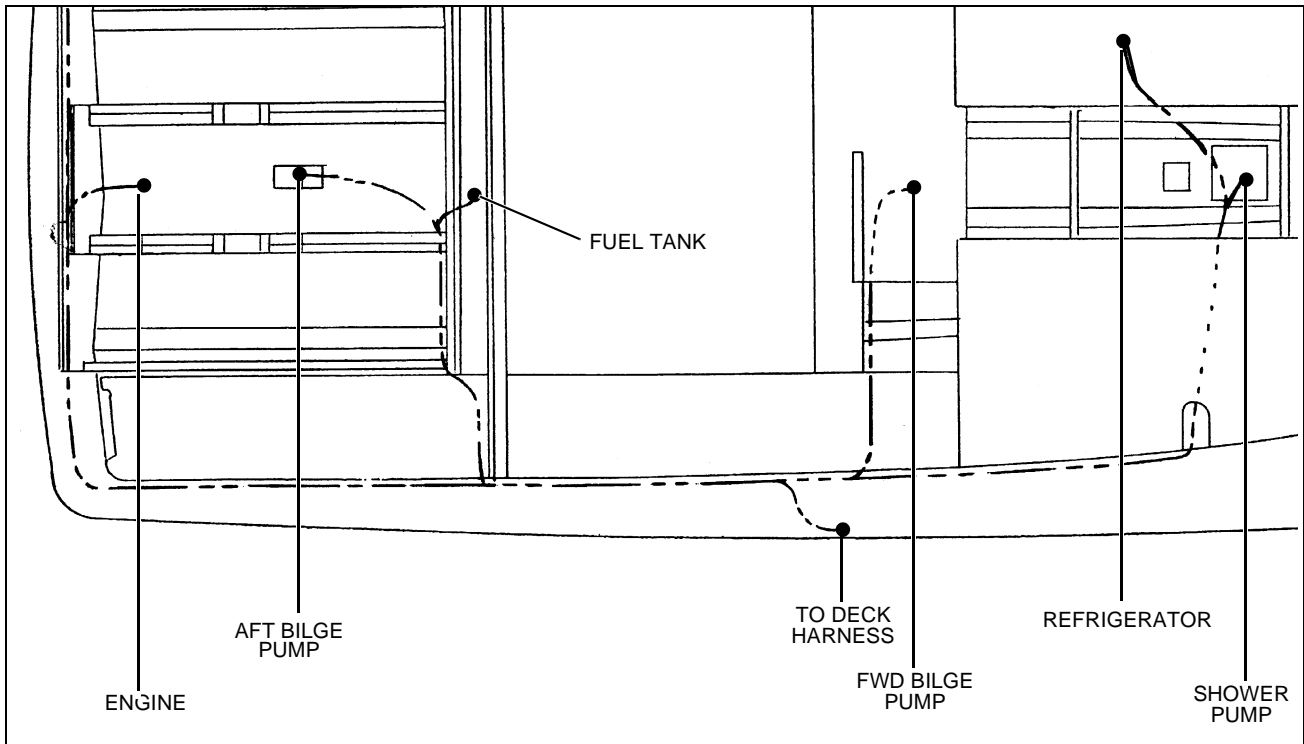

Hull 110 Volt AC Harness

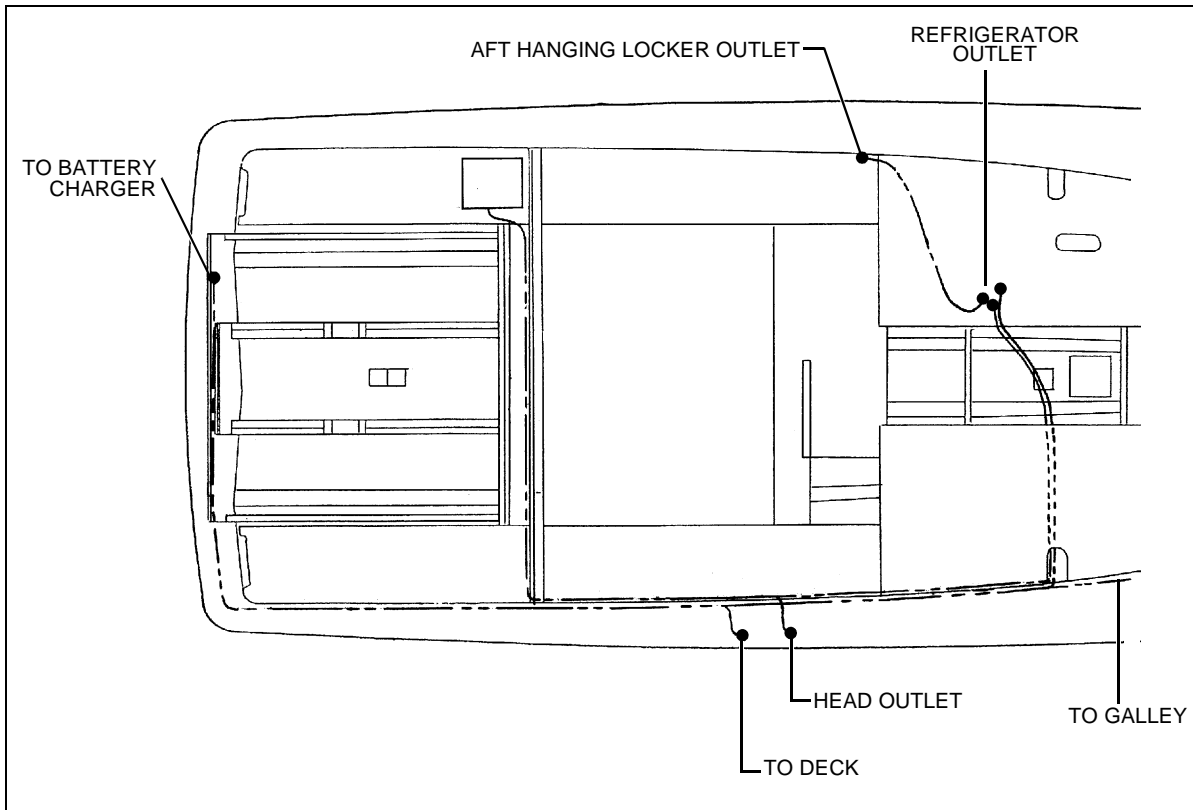

Air Conditioning Routing

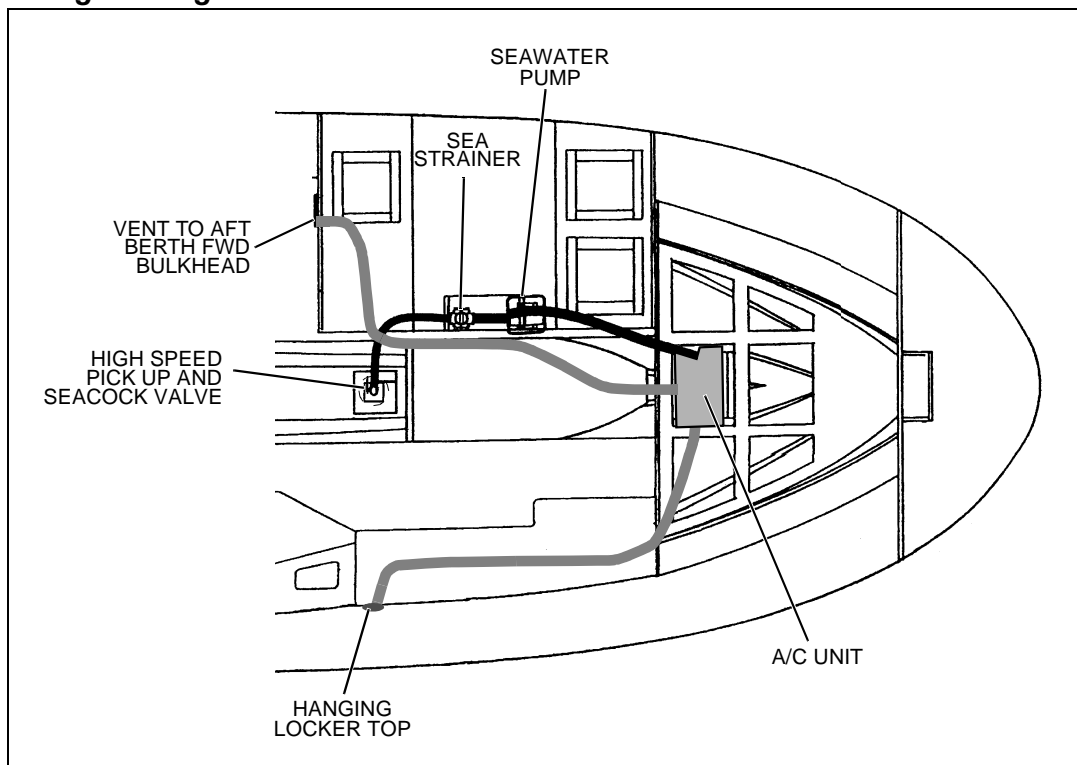

Helm Area

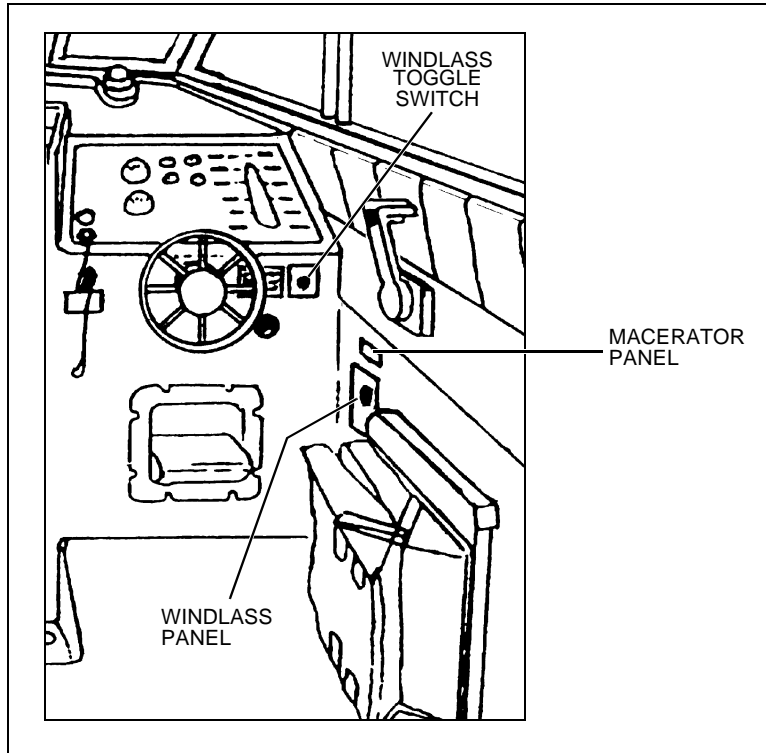

Fuel System

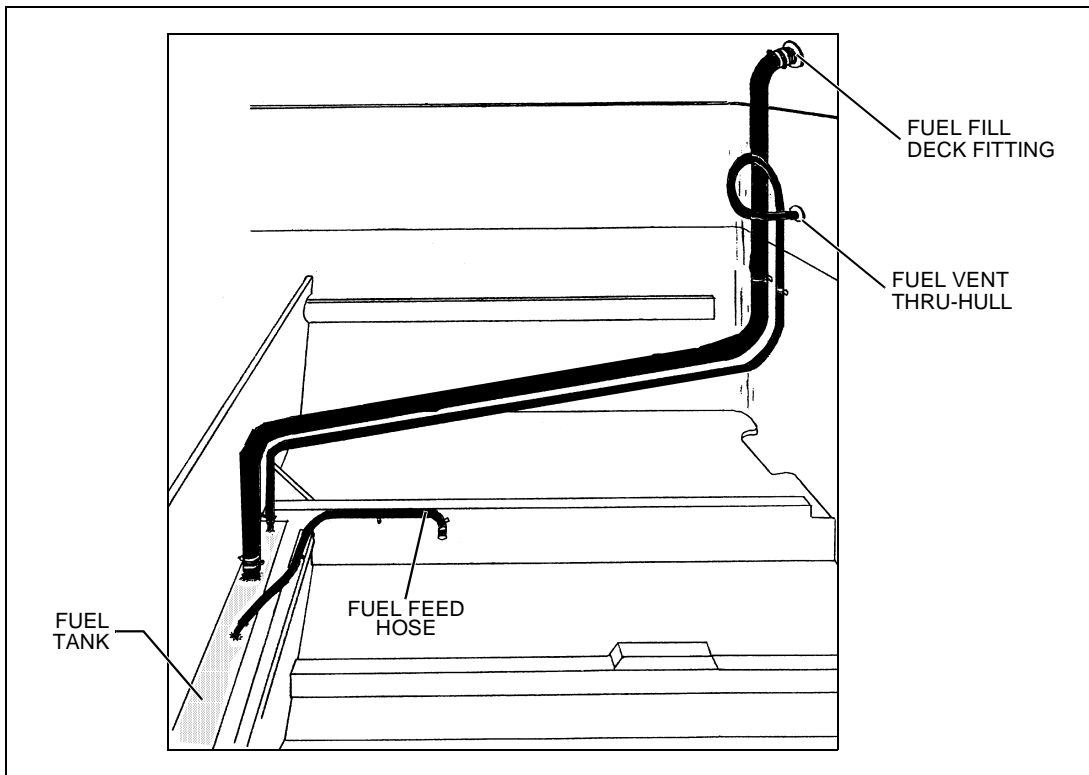

Chapter 4: Wiring Diagrams

Please read the electrical sections included in the Owner's Manual and this Owner's Manual Supplement for important safeguards concerning your boat's electrical system.

2252 Express (CP)

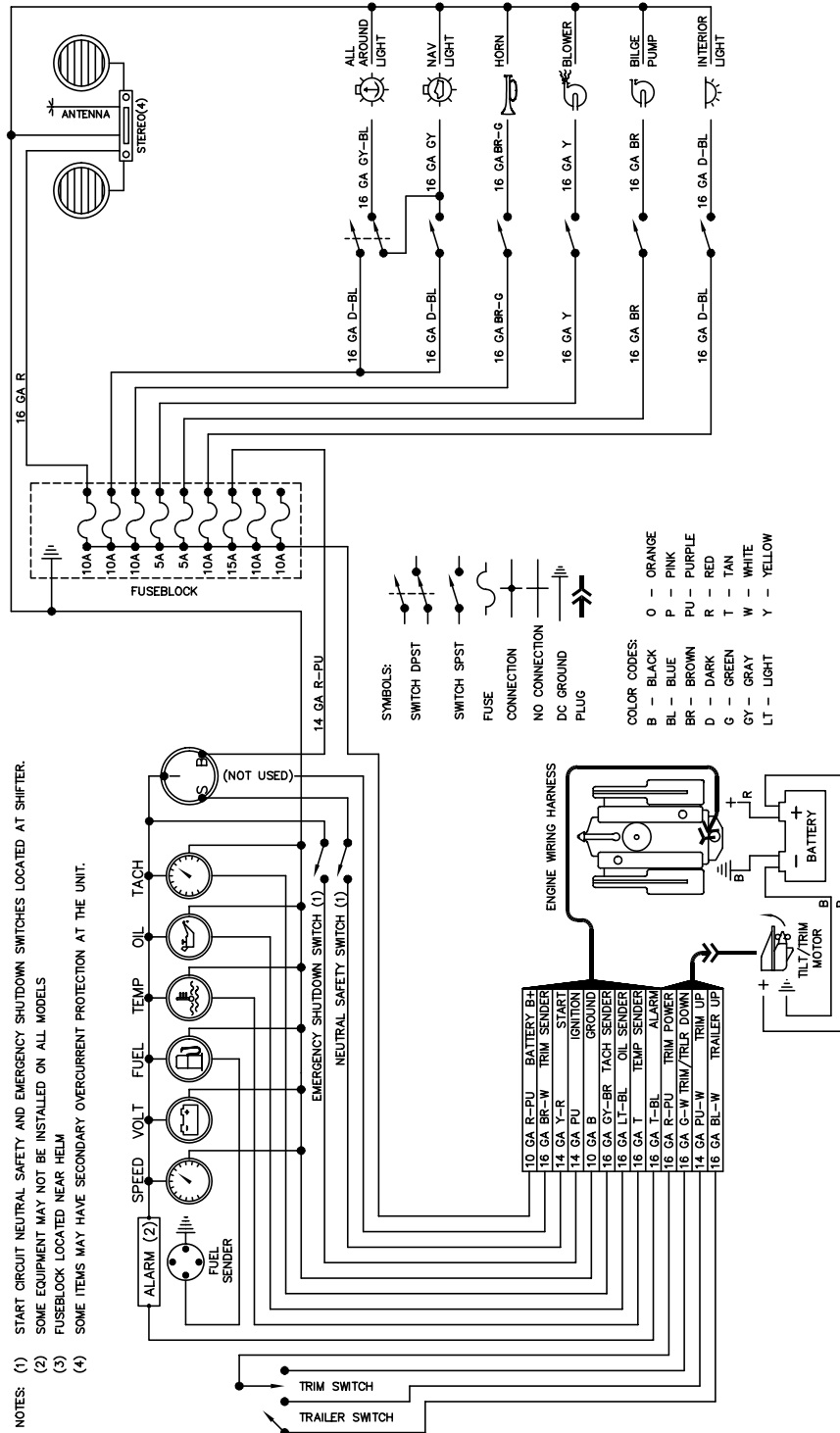

2355 Sunbridge (SJ)

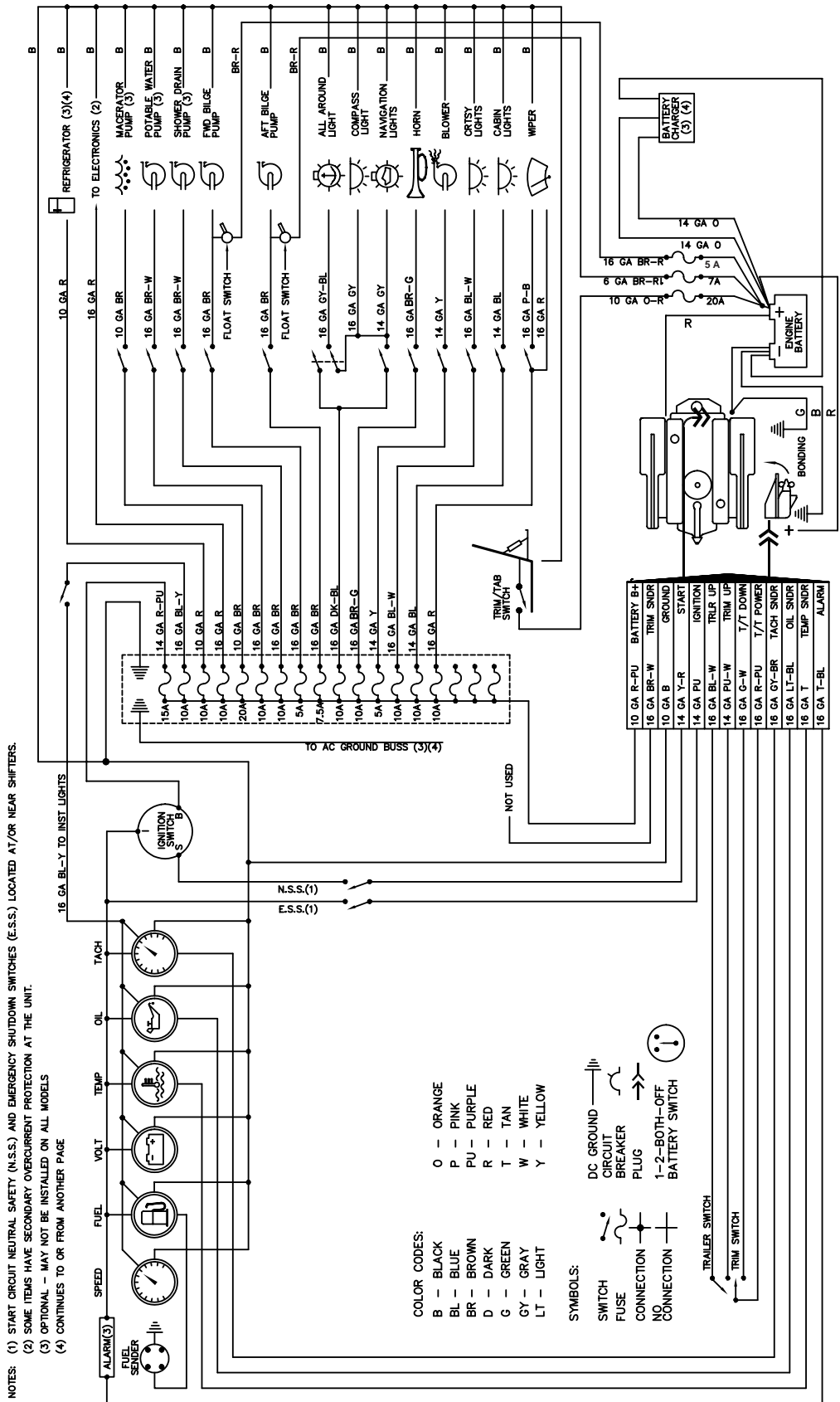

2452 Express (CD)

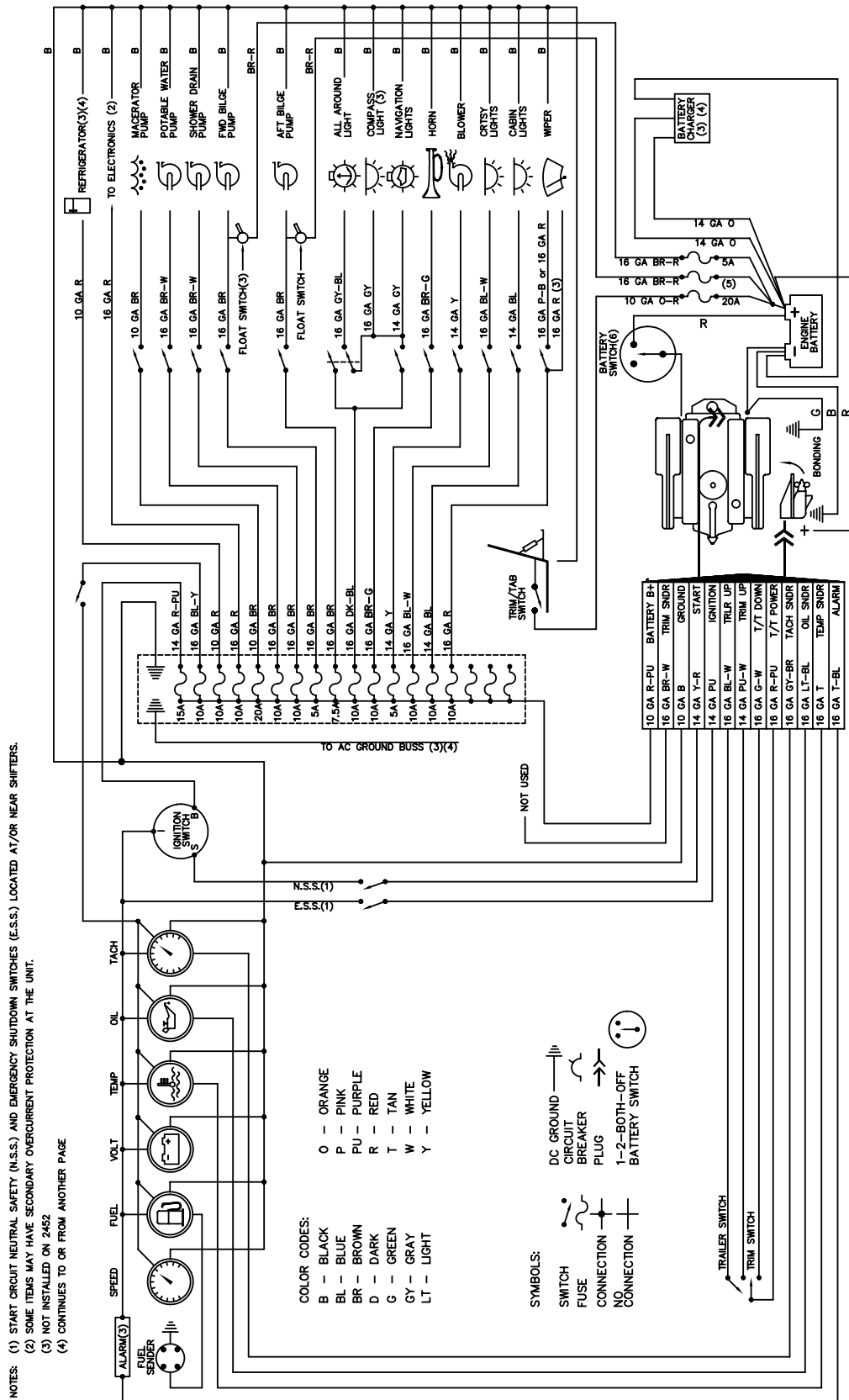

2655 Sunbridge (SB)

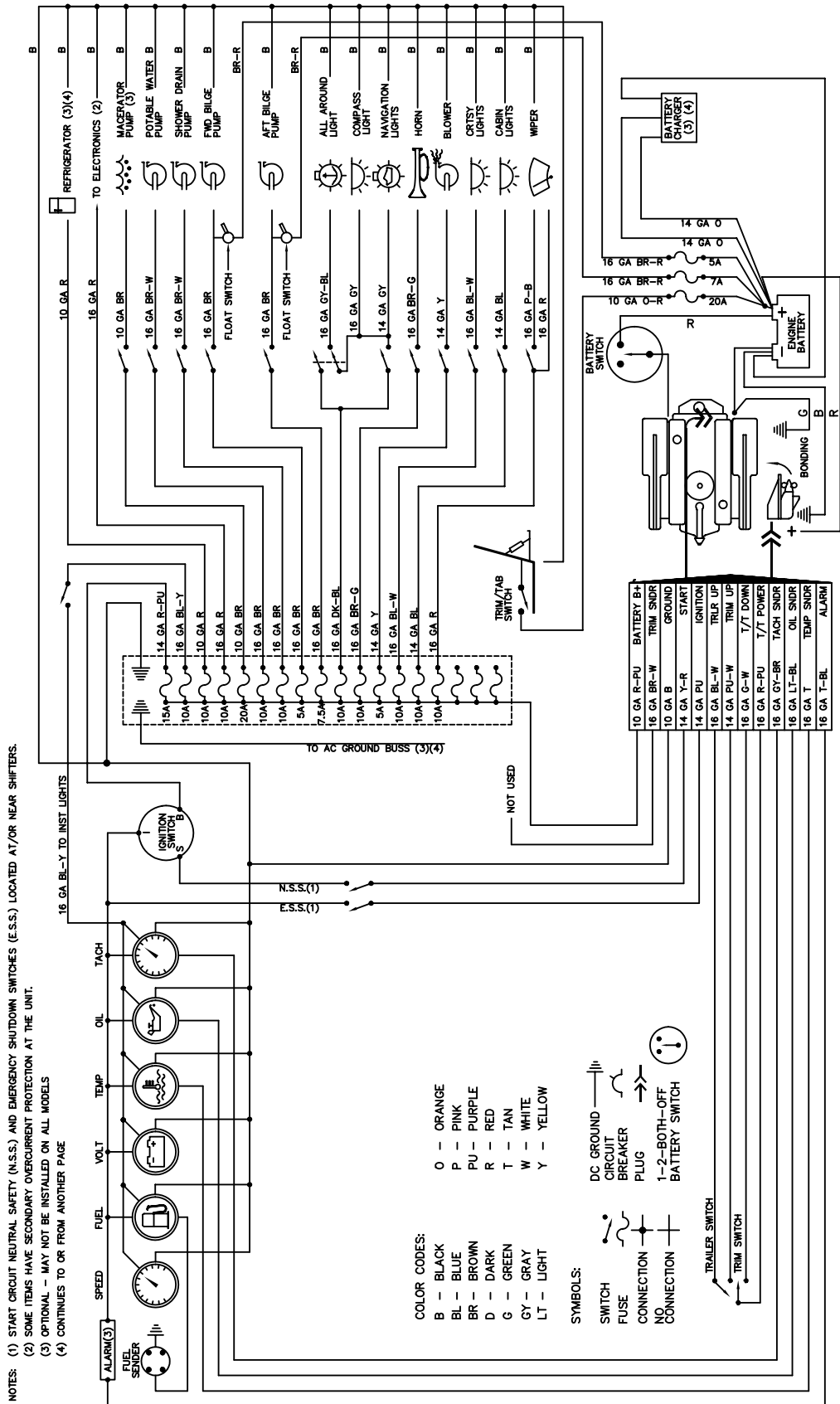

2855 Sunbridge (ST), Gas Engine

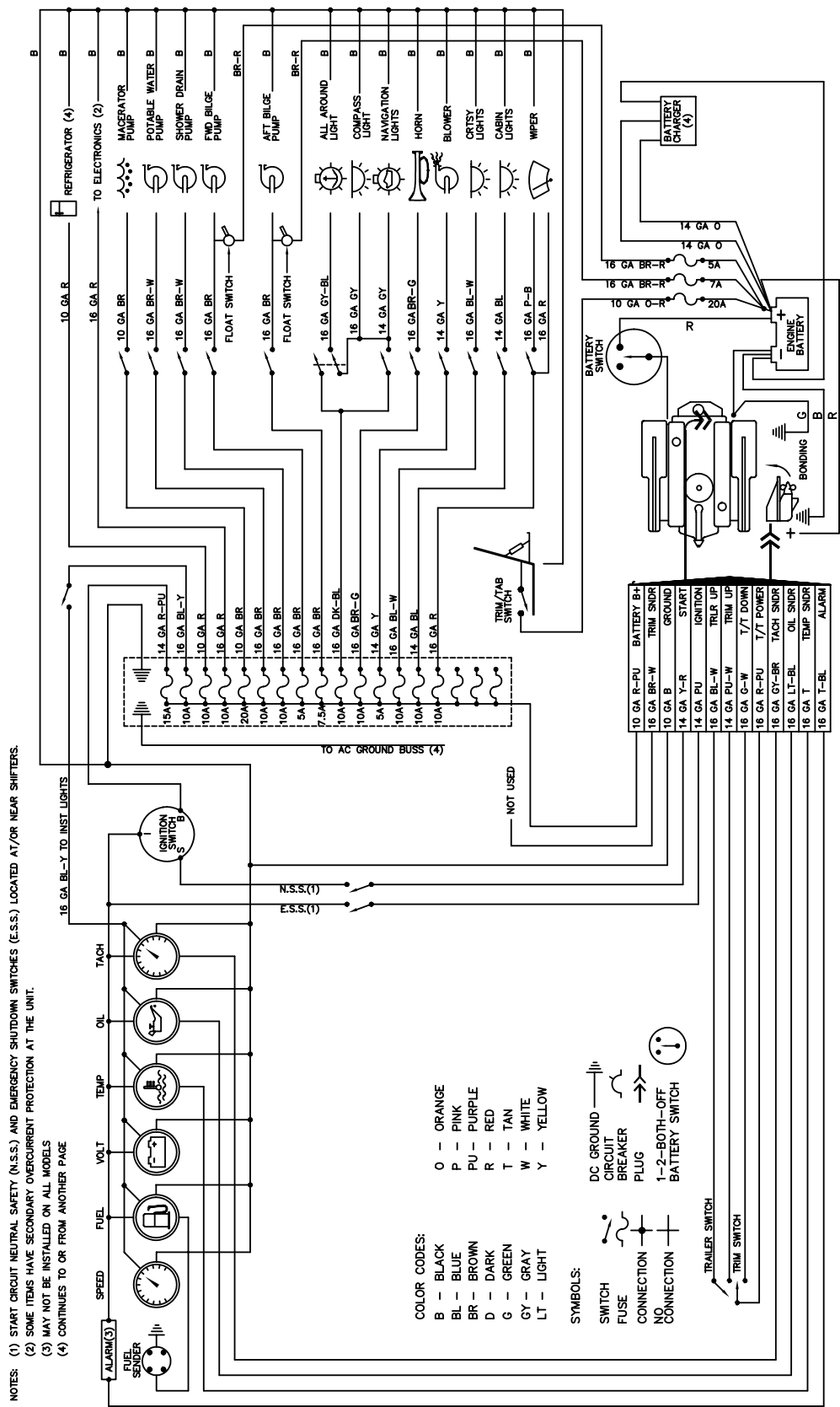

2855 Sunbridge (ST), Diesel Engine

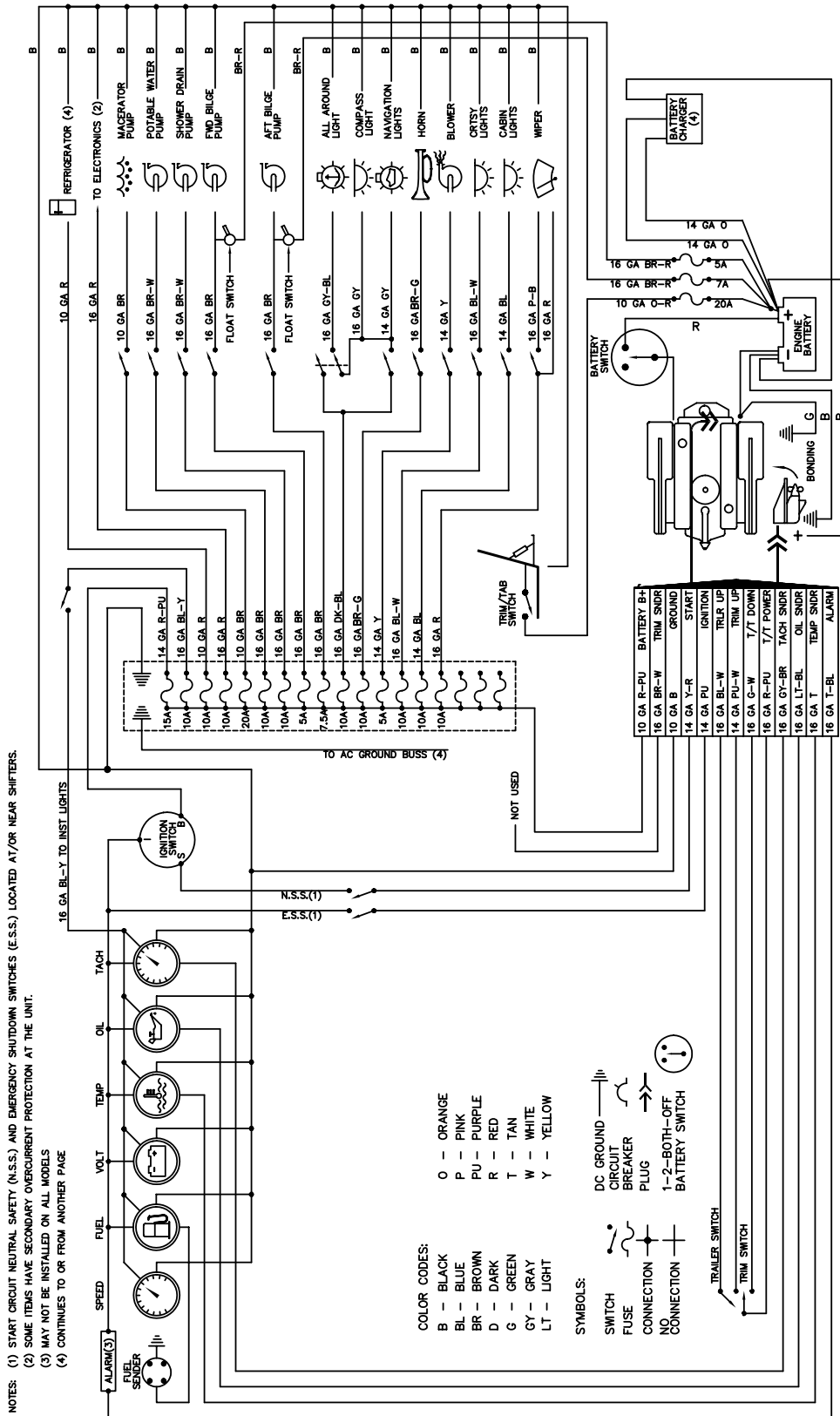

2858 Command Bridge (EC), Gas Engine

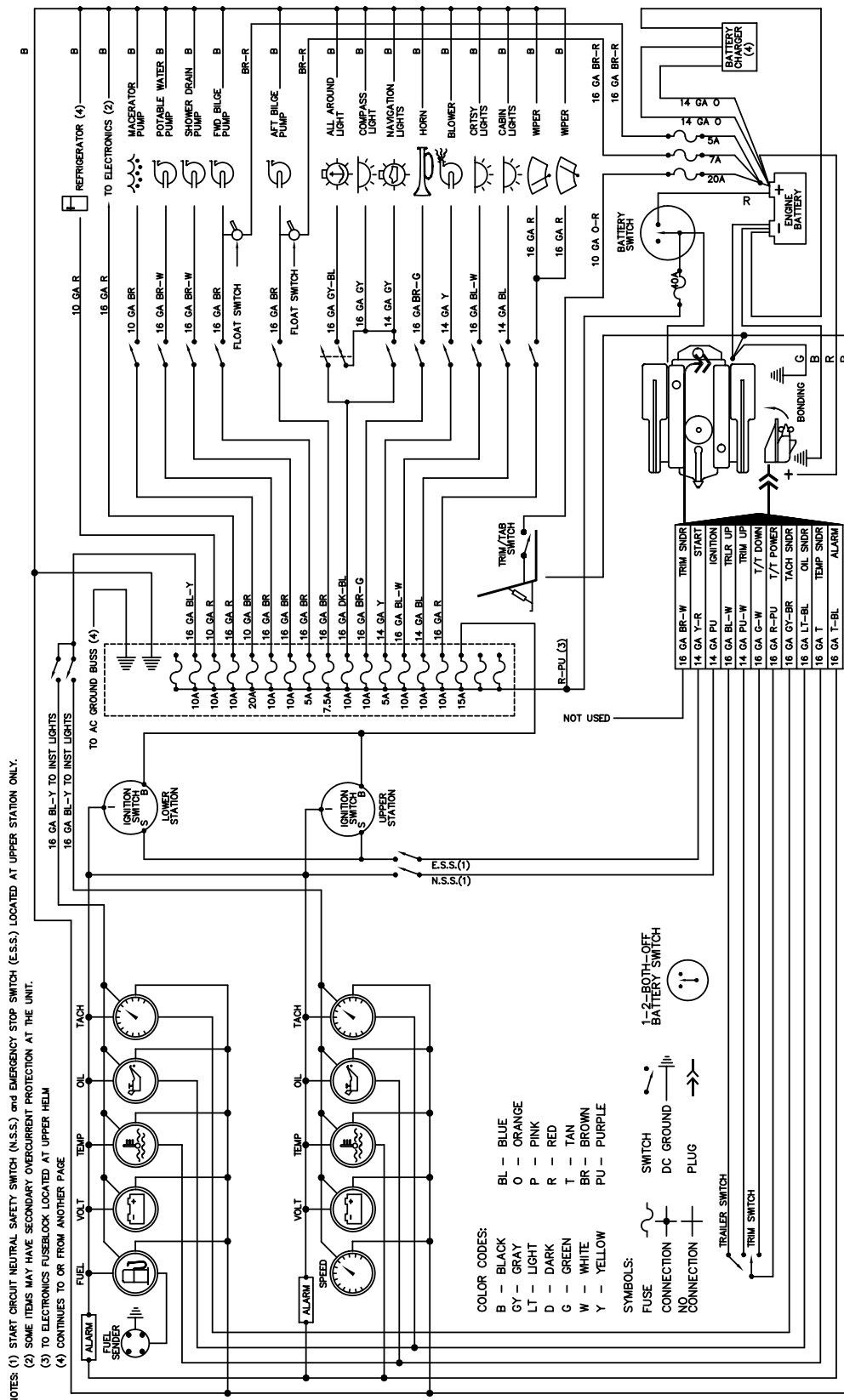

2858 Command Bridge (EC), Diesel Engine

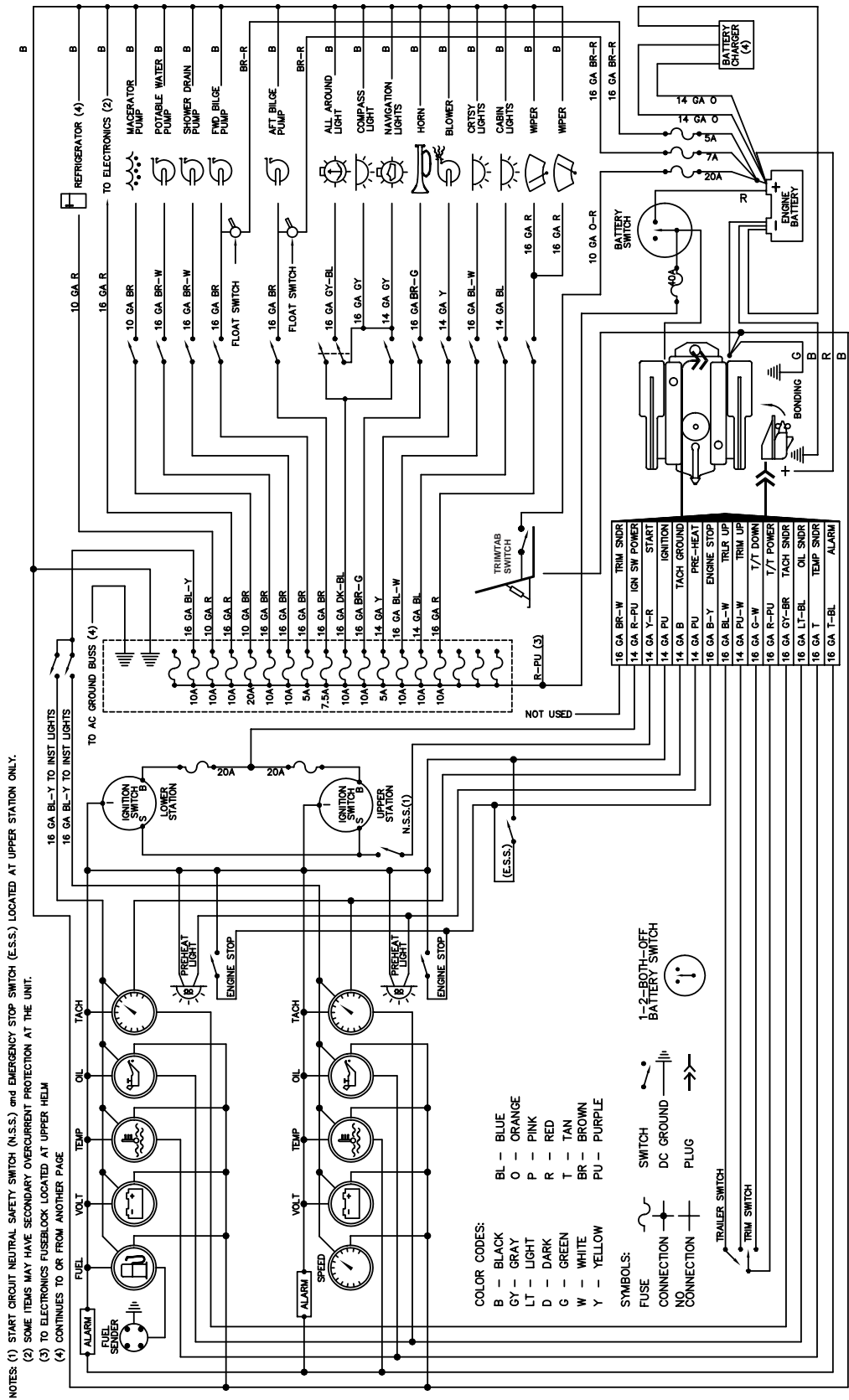

2859 Express (SC), Gas Engine

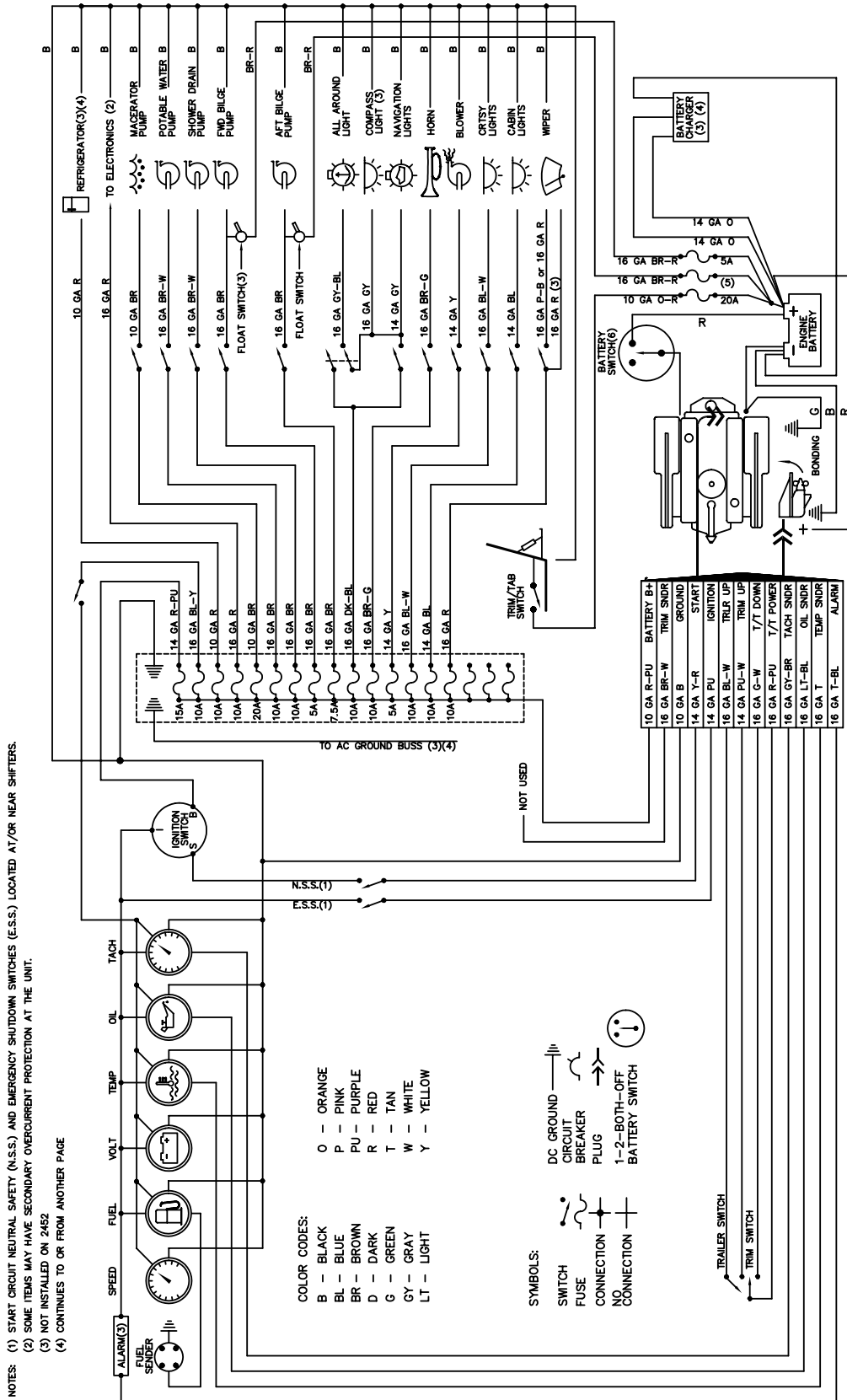

2859 Express (SC), Diesel Engine

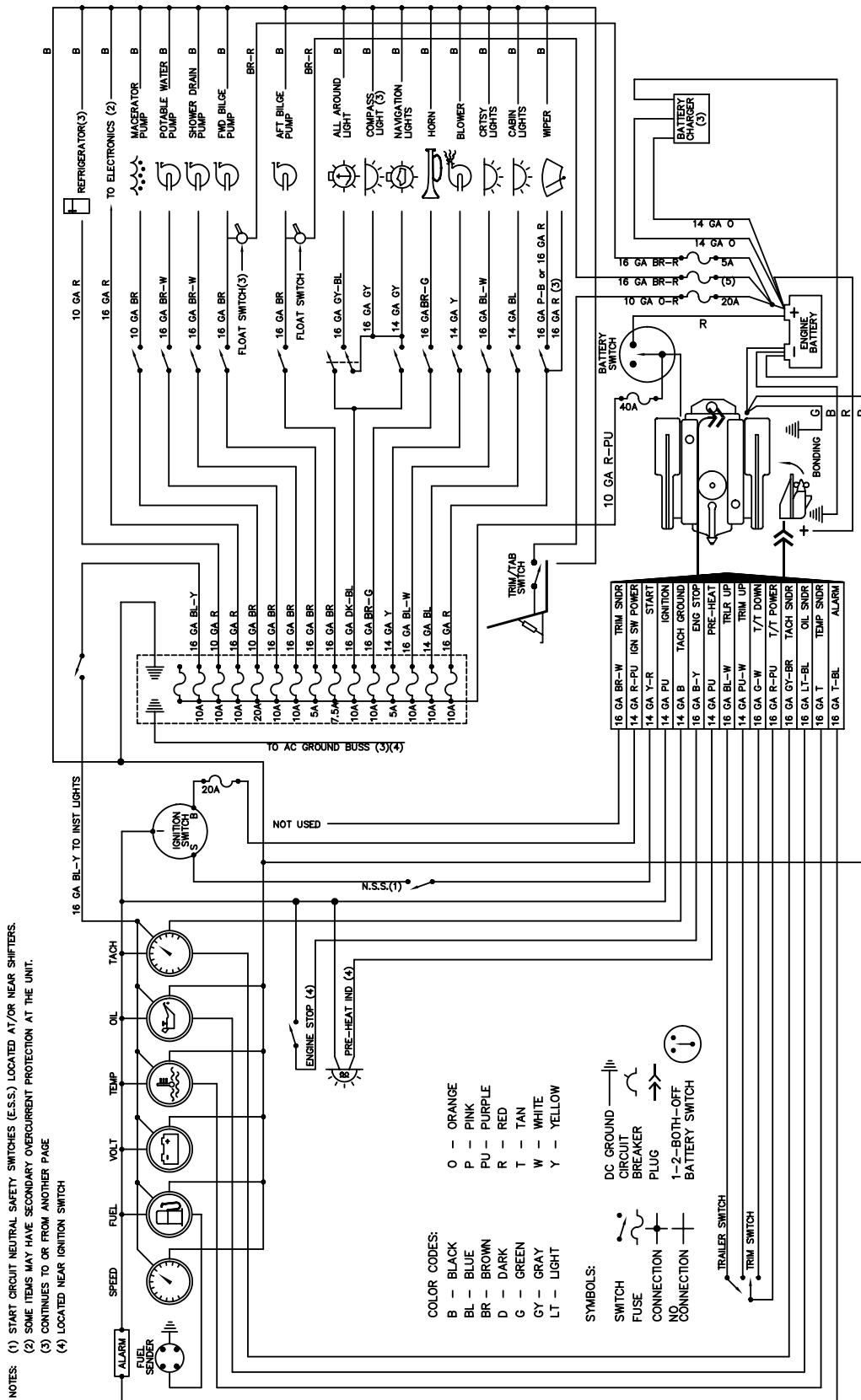

Single Dockside Wiring Diagram

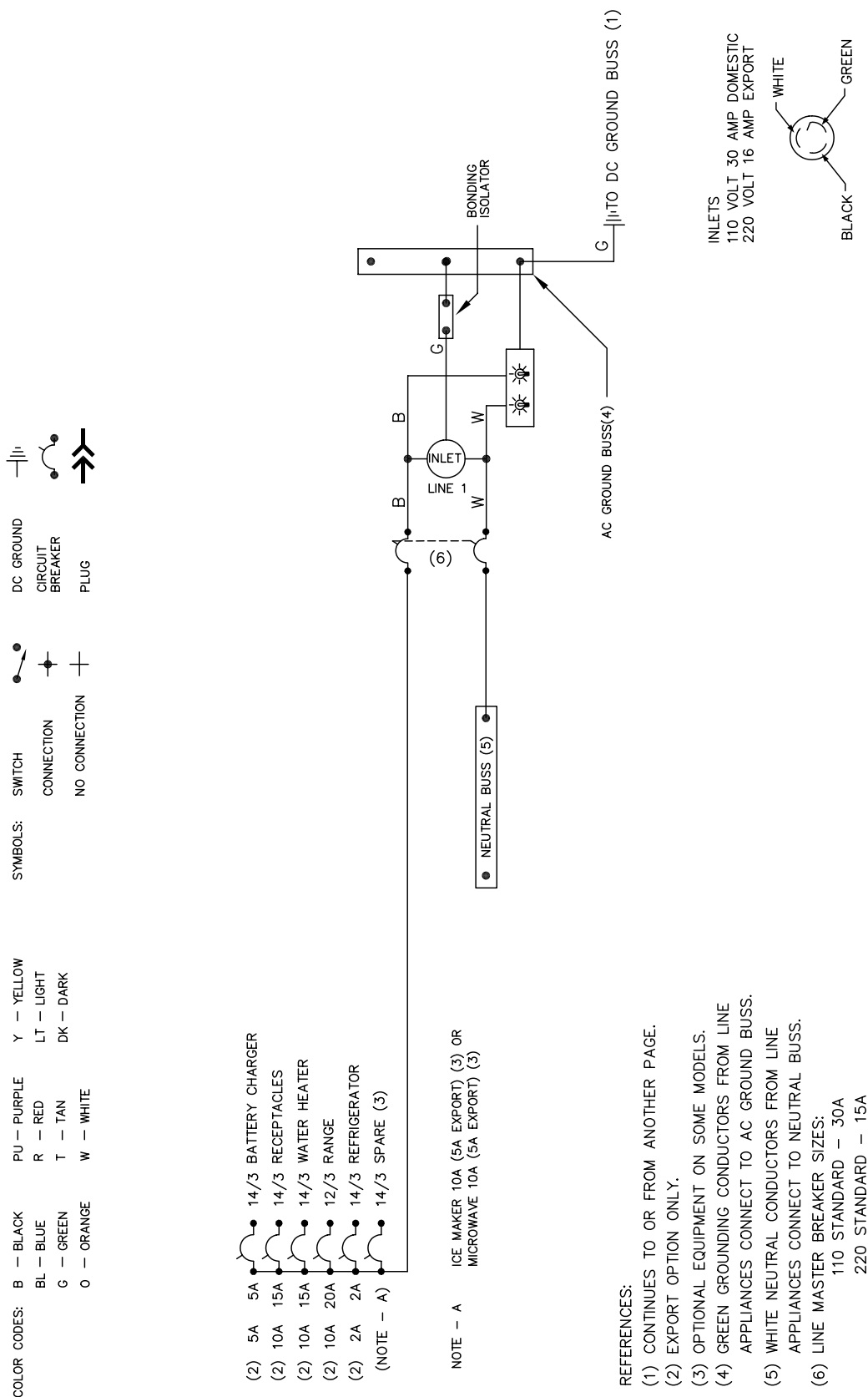

- NOTE - A** ICE MAKER 10A (5A EXPORT) (3) OR MICROWAVE 10A (5A EXPORT) (3)
- REFERENCES:**
- (1) CONTINUES TO OR FROM ANOTHER PAGE.
 - (2) EXPORT OPTION ONLY.
 - (3) OPTIONAL EQUIPMENT ON SOME MODELS.
 - (4) GREEN GROUNDING CONDUCTORS FROM LINE APPLIANCES CONNECT TO AC GROUND BUSS.
 - (5) WHITE NEUTRAL CONDUCTORS FROM LINE APPLIANCES CONNECT TO NEUTRAL BUSS.
 - (6) LINE MASTER BREAKER SIZES:
110 STANDARD — 30A
220 STANDARD — 15A

Double Dockside Wiring Diagram

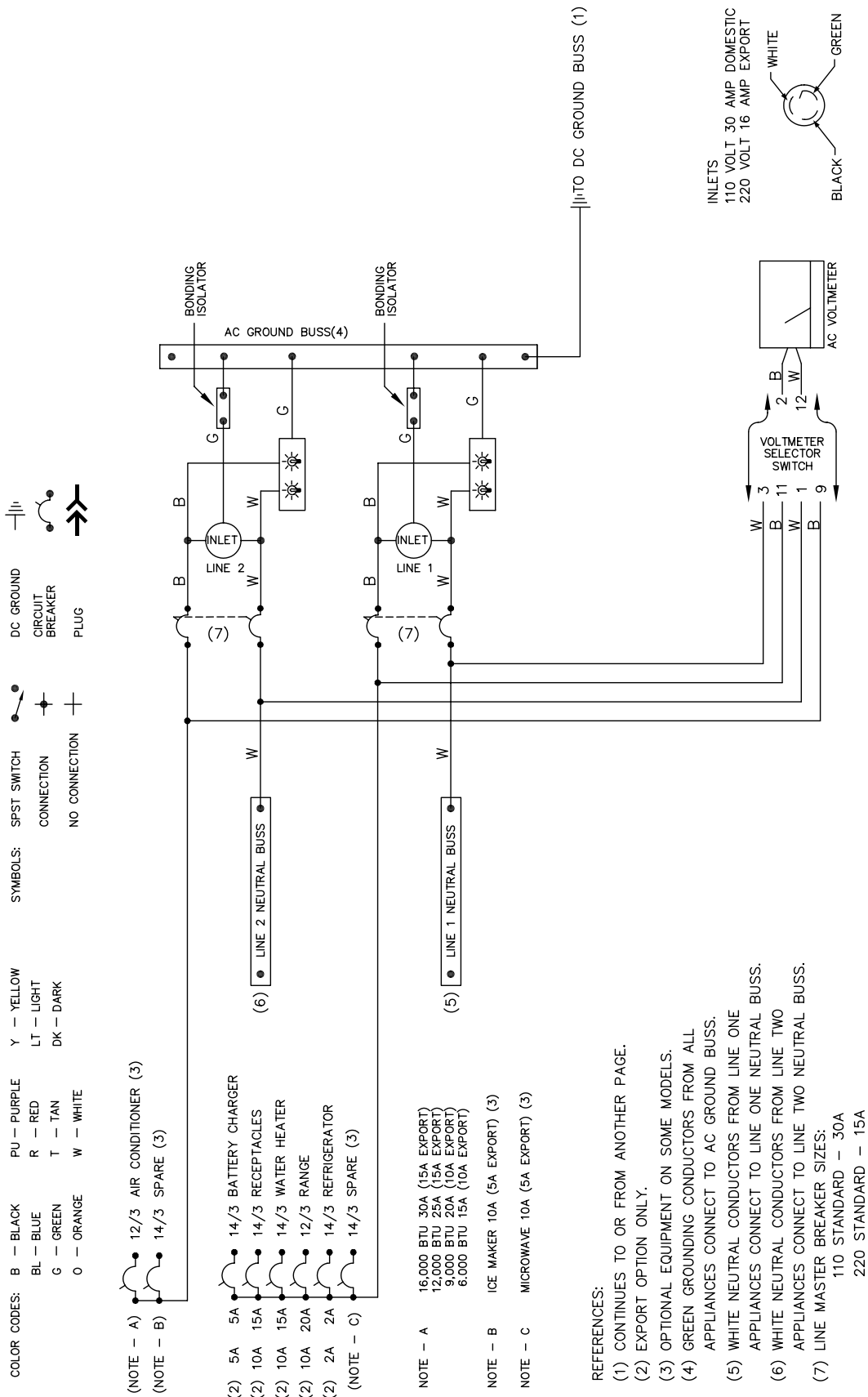

Limited Warranty

Bayliner warrants to the original purchasers of its 1999 and 2000 model boats, purchased from an authorized dealer, operated under normal, noncommercial use that the selling dealer will: (A) Repair any structural hull defect which occurs within five (5) years of the date of delivery; and (B) Repair or replace any parts found to be defective in factory material or workmanship within one (1) year of the date of delivery.

What Is Not Covered

This limited warranty does not apply to:

1. Engines, drive trains, controls, props, batteries, or other equipment or accessories carrying their own individual warranties;
2. Engines, parts or accessories not installed by Bayliner;
3. Plexiglass windscreen breakage; rainwater leakage on runabout models; rainwater leakage through convertible tops; minor gelcoat discoloration, cracks or crazing or air voids;
4. Hull blisters that form below the waterline;
5. Normal deterioration, i.e. wear, tear, or corrosion of hardware, vinyl, tops, vinyl and fabric upholstery, plastic, metal, wood, or trim tape;
6. Any Bayliner boat which has been overpowered according to the maximum horsepower specifications on the capacity plate provided on each Bayliner outboard boat;
7. Any Bayliner boat used for commercial purposes;
8. Any defect caused by failure of the customer to provide reasonable care and maintenance.

Other Limitations

THERE ARE NO OTHER EXPRESS WARRANTIES ON THIS BOAT. TO THE EXTENT ALLOWED BY LAW:

1. ANY IMPLIED WARRANTY OF MERCHANTABILITY OR FITNESS FOR A PARTICULAR PURPOSE IS LIMITED TO THE DURATION OF ONE YEAR.
2. Neither Bayliner nor the selling dealer shall have any responsibility for loss of use of the boat, loss of time, inconvenience, commercial loss or consequential damages.
3. Some jurisdictions do not allow limitations on how long any implied warranty lasts, so the above limitation may not apply to you. Some jurisdictions do not allow the exclusion or limitation of incidental or consequential damages, so the above limitation or exclusion may not apply to you. This limited warranty gives you specific legal rights, and you may also have other rights which vary from state to state.

Your Obligation

In order to comply with regulations, it is essential that your limited warranty registration card be submitted within 30 days of delivery of your boat. Return of the limited warranty registration card is a condition precedent to limited warranty coverage. Before any warranty work is performed, we require that you contact your dealer to request warranty assistance.

YOU MUST GIVE US WRITTEN NOTICE OF YOUR WARRANTY CLAIM PRIOR TO THE EXPIRATION OF YOUR LIMITED WARRANTY AND ALLOW US AN OPPORTUNITY TO RESOLVE THE MATTER.

We require that you return your boat, at your expense, to your selling dealer or, if necessary, to the Bayliner factory. You will be responsible for all transportation, haulouts and other expenses incurred in returning the boat for warranty service.

Bayliner • 133 Weyerhaeuser Drive • Roseburg, OR 97470 • Phone: 541-464-5882 • FAX: 541-673-0426

Part Number 1706166

Bayliner • P.O. Box 9029 • Everett, WA 98206 • 360-435-5571