

BRUNNEN

Rendezvous

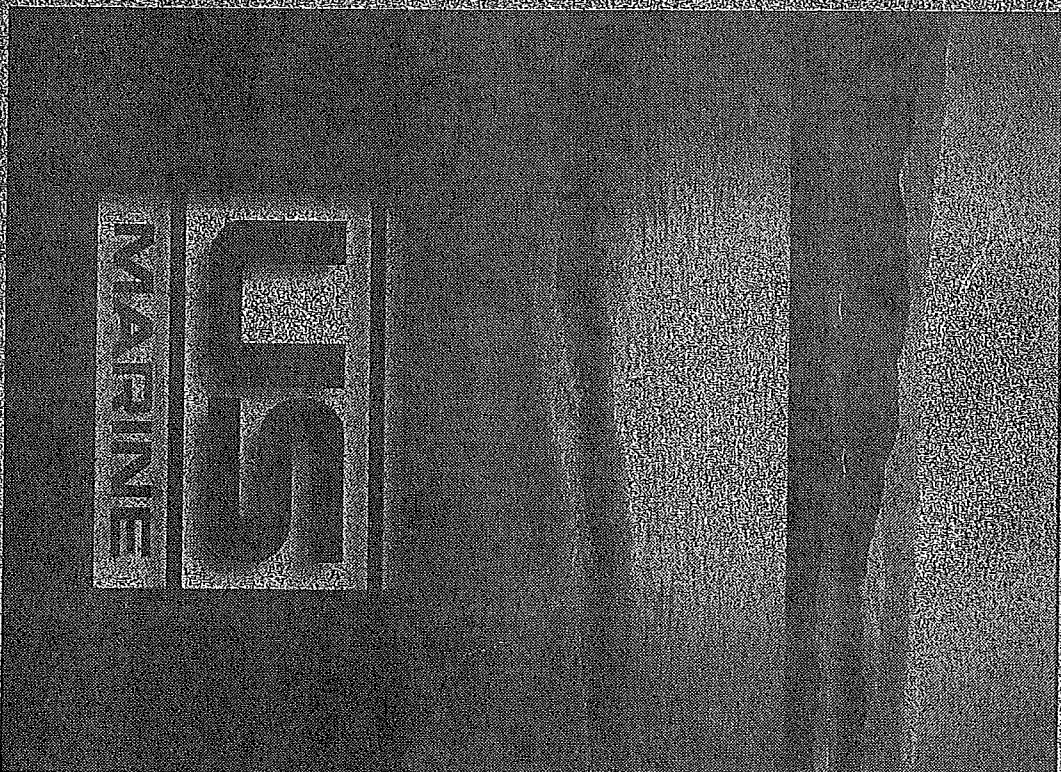

Owner's Manual Supplement



TO BE THE BEST

For Total Customer Satisfaction

Congratulations and welcome aboard your new Rendezvous boat!

Thank you for choosing our product. Brunnen, a division of US Marine, is committed to the goal of building the highest quality products in the marine industry and to providing the finest after-the-sale support in the world.

To keep our respected status as the number one boat builder in the world, US Marine has instituted an ongoing *Total Customer Satisfaction Program*.

The guiding principles of this program are:

- ✓ *Design, build and support the finest marine products in the world, in every market we serve.*
- ✓ *Be personally and individually responsible for the customer's total satisfaction.*
- ✓ *Remember that every customer has a choice, and we want them to choose US Marine!*

Welcome to the US Marine family. We are looking forward to serving your boating needs, now and in the future!

BRUNNEN® is a division of US Marine, a Brunswick company

CHAPTER 1: WELCOME ABOARD!

- 1 Dealer Service
- 1 Boating Experience
- 1 Structural Limitations
- 2 Engines & Accessories Guidelines
- 2 Safety Standards
- 2 Qualified Maintenance
- 3 Special Care For Moored Boats
- 3 Hazard Boxes & Symbols

CHAPTER 2: PRODUCT SPECIFICATIONS

- 4 2109 (GF)
- 4 2159 (GH)
- 4 2459 (GB)
- 4 2659 (GD)

CHAPTER 3: COMPONENTS / SYSTEMS

- 5 Electrical System
- 6 DC Electrical System
- 6 Navigation Lights
- 7 AM/FM Cassette Stereo
- 7 Propulsion
- 8 Bilge Systems
- 9 Fuel System
- 10 Freshwater Systems
- 11 Live Well System (Option)
- 11 Portable Head
- 11 Deck Equipment
- 12 Canvas Installation

CHAPTER 4: SYSTEM DIAGRAMS

- 14 2109 (GF)
- 17 2159 (GH)
- 21 2459 (GB)
- 25 2659 (GD)

CHAPTER 5: WIRING SCHEMATICS

- 29 Engine/Accessory Harnesses
- 33 Deck Harnesses
- 34 Bilge Harness
- 34 Trolling Motor Harness
- 34 Water Pump Harness
- 35 Fuse Block Harness

APPENDIX A: LIMITED WARRANTY

- 36 What Is Not Covered
- 36 Other Limitations
- 36 Your Obligation

CHAPTER 1: WELCOME ABOARD!

This Owner's Manual Supplement contains specific information about the following 1999/2000 Rendezvous boats:

2109 (GF), 2159 (GH), 2459 (GB), 2659 (GD)

This owner's manual supplement provides specific information about your boat that is not covered in the owner's manual. Please study the owner's manual and this supplement carefully, paying particular attention to Appendix A: LIMITED WARRANTY. Keep the owner's manual and this supplement on your boat in a secure, yet readily available place.

Dealer Service

Make sure you receive a full explanation of all systems from the selling dealer before taking delivery of your boat. Your selling dealer is your key to service. If you experience any problems with your new boat, immediately contact the selling dealer. If for any reason your selling dealer is unable to help, you can call us direct on our customer service hotline: 360-435-8957 or send us a FAX: 360-403-4235.

Boating Experience

If this is your first boat or if you are changing to a type of boat you are not familiar with, for your own comfort and safety, please ensure that you obtain handling and operating experience before assuming command of the boat.

We strongly recommend that you take one of the boating safety classes offered by the U.S. Power Squadrons or the U.S. Coast Guard Auxiliary. For more course information, including dates and locations of upcoming classes, contact the organizations directly:

- U.S. Power Squadrons: 1-888-FOR-USPS (1-888-367-8777) or on the Internet at: <http://www.usps.org>
- U.S. Coast Guard Auxiliary: 1-800-368-5647 or on the Internet at: <http://www.cgaux.org>

Outside the United States, your selling dealer, national sailing federation or local yacht club can advise you of local sea schools or competent instructors.

▲ WARNING!

CONTROL HAZARD! A qualified operator must be in control of the boat at all times. **DO NOT** operate your boat while under the influence of alcohol or drugs.

Structural Limitations

The transom platform and bow platform are designed to be lightweight for proper boat balance. The load limit for these platforms is 30 pounds per square foot, evenly distributed.

Engines & Accessories Guidelines

Your boat's engines and accessories were selected to provide optimum performance and service. Installing different engines or accessories may cause unwanted handling characteristics. Should you choose to install different engines or add accessories that will affect the boat's running trim, have an experienced marine technician perform a safety inspection and handling test before operating your boat again.

Please be advised that certain modifications to your boat can result in cancellation of your limited warranty protection. Always check with your dealer before making any modifications to your boat.

The engines and accessories installed on your boat come with their own operation and maintenance manuals. We strongly urge you to read and understand these manuals before operating the engines and accessories.

Safety Standards

Your boat's mechanical and electrical systems were designed to meet safety standards in effect at the time it was built. Some of these standards were mandated by law; all of them were designed to insure your safety, and the safety of other people, vessels and property.

In addition to this supplement, please read the owner's manual and all accessory instruction sheets included in your owner's packet for important safety standards and hazard information.

⚠ DANGER!



PERSONAL SAFETY HAZARD/ DO NOT allow anyone to ride on parts of the boat not designated for such use. Sitting on seat backs, lounging on the forward deck, bow riding, gunwale riding or occupying the transom platform while underway is especially hazardous and **WILL** cause personal injury or death.

Qualified Maintenance

Failure to maintain your boat's systems as designed could violate the laws in your jurisdiction and could expose you and other people to the danger of bodily injury or accidental death. We recommend that you follow all maintenance instructions provided in the owner's manual, this supplement, the engine owner's manual as well as all accessory instruction sheets and manuals included in your boat's owner's packet.

⚠ WARNING!

To maintain the integrity and safety of your boat, only qualified personnel should perform maintenance on, or in any way modify: The steering system, propulsion system, engine control system, fuel system, environmental control system, electrical system or navigational system.

Special Care For Moored Boats

If moored in saltwater or fresh water, your boat will collect marine growth on its hull bottom. This will detract from the boat's beauty, greatly affect its performance and may damage the gelcoat. There are two methods of slowing marine growth:

- Periodically haul the boat out of the water and scrub the hull bottom with a bristle brush and a solution of soap and water.
- Paint the hull below the waterline with a good grade of anti-fouling paint.

NOTICE

To help seal the hull bottom and reduce the possibility of gelcoat blistering on moored boats, we recommend the application of an epoxy barrier coating, such as Interlux, Interprotect 2000E/2001E. The barrier coating should be covered with several coats of anti-fouling paint.

Many states regulate the chemical content of bottom paints in order to meet environmental standards. Check with your local dealer about recommended bottom paints, and about the laws in effect in your area.

Hazard Boxes & Symbols

The hazard boxes and symbols shown below are used throughout this supplement to call attention to potentially dangerous situations which could lead to either personal injury, death or product damage. We urge you to read all hazard warnings carefully and follow all safety recommendations.

HOT HAZARD	EXPLOSION HAZARD	ELECTRICAL HAZARD	OPEN FLAME HAZARD	PERSONAL INJURY & FALLING HAZARD	ROTATING PROPELLER HAZARD

⚠ DANGER!

This box alerts you to immediate hazards which **WILL** cause severe personal injury or death if the warning is ignored.

⚠ WARNING!

This box alerts you to hazards or unsafe practices which **COULD** result in severe personal injury or death if the warning is ignored.

⚠ CAUTION!

This box alerts you to hazards or unsafe practices which **COULD** result in minor personal injury or cause product or property damage if the warning is ignored.

NOTICE

This box calls attention to installation, operation or maintenance information, which is important to proper operation but is not hazard related.

CHAPTER 2: PRODUCT SPECIFICATIONS

2109 (GF)

Length overall - 21' 3"
 Beam - 8' 3"
 Deadrise - 16 degrees
 Weight (standard engine) - 3,1458 lb.
 Draft hull - 1' 3"
 Draft max - 2' 8"
 Bridge clearance - 4' 2"
 Fuel capacity - 45 gal.
 Freshwater capacity (option) - 19 gal.

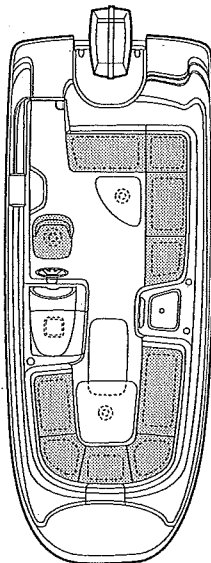

2159 (GH)

Length overall - 21' 3"
 Beam - 8' 3"
 Deadrise - 16 degrees
 Weight - 3,750 lb.
 Draft hull - 1' 4"
 Draft max - 2' 8"
 Bridge clearance - 4' 1"
 Fuel capacity - 45 gal.
 Freshwater capacity (option) - 19 gal.

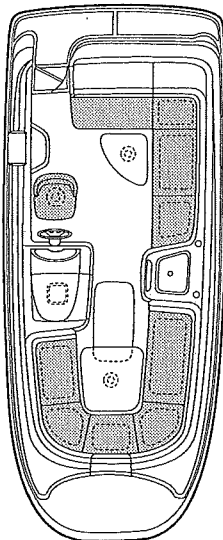

2459 (GB)

Length overall - 24' 0"
 Beam - 8' 3"
 Deadrise - 17 degrees
 Weight - 4,333 lb.
 Draft hull - 1' 4"
 Draft max - 2' 9"
 Bridge clearance - 4' 3"
 Fuel capacity - 65 gal.
 Freshwater capacity (option) - 19 gal.

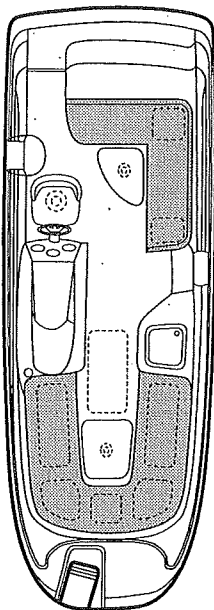

2659 (GD)

Length overall - 26' 5"
 Beam - 8' 5"
 Weight - 4,898 lb.
 Draft hull - 1' 1"
 Draft max - 2' 6"
 Bridge clearance - 4' 5"
 Fuel capacity - 57 gal.
 Freshwater capacity - 13 gal.

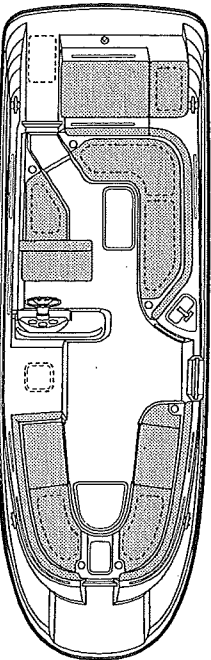

CHAPTER 3: COMPONENTS / SYSTEMS

Electrical System

We strongly recommend that you thoroughly read and understand the electrical sections of the owner's manual and all accessory manuals included in your boat's owner's packet. Wiring schematics are provided in chapter 5 of this supplement.

⚠ DANGER!

FIRE, SHOCK & EXPLOSION HAZARD!

- DO NOT modify the electrical systems or relevant drawings. Only qualified personnel should install batteries and/or perform maintenance on the electrical system.
- To minimize the risks of fire and explosion, NEVER install knife switches or other arcing devices in the fuel compartments. NEVER substitute automotive parts for marine parts. Electrical, ignition and fuel system parts were designed and manufactured to comply with rules and regulations that minimize risks of fire and explosion.

⚠ WARNING!

FIRE & EXPLOSION HAZARD!

- Fuel fumes are heavier than air and will collect in the bilge areas where they can be accidentally ignited. Visually and by smell (sniff test), check the engine and fuel compartments for fumes or accumulation of fuel. Always operate the bilge blowers for at least four minutes prior to engine starting, electrical system maintenance or activation of electrical devices.
- To minimize the danger of fire and explosion, DO NOT expose batteries to open flame or sparks.
- DO NOT smoke anywhere near the batteries.

⚠ CAUTION!

SHOCK & ELECTRICAL SYSTEM DAMAGE HAZARD!

- NEVER disconnect the battery cables while the engine is running since damage may occur to your boat's electrical system components.
- The battery charging system (alternator) installed on your boat are designed to charge conventional lead-acid batteries. Before installing gel-cell or other new technology batteries, consult with the battery manufacturer about charging system requirements.

NOTICE

Electrical connections are prone to corrosion. To reduce electrical problems caused by corrosion, keep all electrical connections clean and apply a spray-on protectant that is designed to protect connections from corrosion.

DC Electrical System

All Rendezvous models are equipped with a 12 volt DC (direct current) system.

Fuses and Circuit Breakers

- Fuses and circuit breakers for engines and main accessory power are located on the dash.
- Electronics power is provided at the helm.
- Some equipment may have secondary fuse protection at the unit.

Battery Maintenance

Corroded battery terminals can be cleaned with baking soda and water. After cleaning the terminals, be sure to coat them with a light film of battery terminal lubricant and tighten all battery connections.

Depth Finder (Option)

Your boat may feature an optional depth finder (depth sounder) at the helm. The depth finder provides you with measurements of water depth beneath the boat. Be sure to read the depth finder owner's manual for detailed operating instructions.

⚠ WARNING!

- **DO NOT** use the depth finder as a navigational aid to prevent collision, grounding, boat damage or personal injury.
- When the boat is moving, submerged objects will not be seen until they are already under the boat. Bottom depths may change too quickly to allow time for the boat operator to react. If you suspect shallow water or submerged objects, operate the boat at very slow speeds.

Navigation Lights

We strongly recommend that you understand navigation light usage by reading the navigation light section of the owner's manual. The navigation lights are of top quality, but you should be aware that failure may periodically occur for a variety of reasons:

- There may be a blown fuse - *replace the fuse in the switch panel.*
- The bulb may be burned out - *carry spare bulbs for replacement.*
- A wire may be damaged or may have come loose - *repair as required.*
- The bulb base may be corroded - *clean the base and coat it with non-conductive electrical lubricant.*

⚠ CAUTION!

Avoid the storage of gear where it would block navigation lights from view.

AM/FM Cassette Stereo

Your boat comes standard-equipped with an AM/FM cassette stereo. The stereo comes with its own instruction manual that explains its operating procedures in detail.

NOTICE

AM radio reception may be impaired in areas where reception is limited or anytime the engines are running.

Propulsion

Engine

The owner's packet contains detailed engine operation and maintenance manuals. Be sure to read and understand these manuals before operating or performing maintenance to your boat's engine.

Engine Compartment Ventilation System

Bilge blowers are installed on all inboard boats to remove fumes from the engine compartment.

To ensure fresh air circulation, operate the bilge blowers in the following situations:

- At least four (4) minutes prior to starting the engine and during engine starting.
- Anytime your boat is operating below cruising speed.

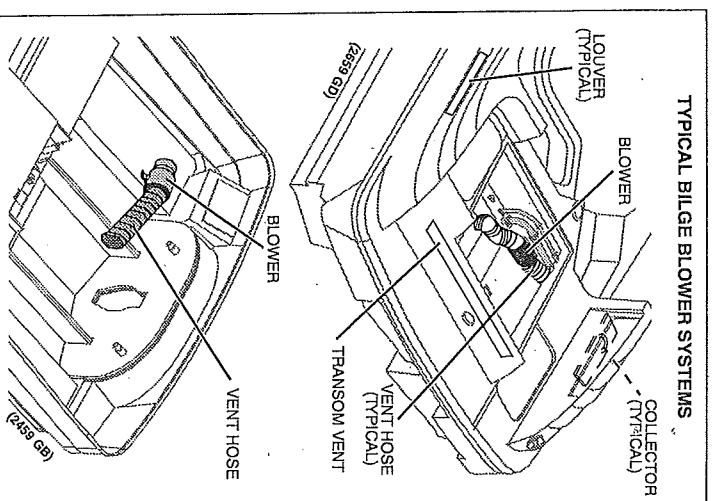

⚠ WARNING!

EXPLOSION HAZARD!

- Operation of the blower system is **NOT** a guarantee that explosive fumes have been removed. If you smell fuel, **DO NOT** start the engines. If the engines are already running, immediately shut off the engines and all electrical accessories and investigate immediately.
- **DO NOT** obstruct or modify the ventilation system.

Bilge Systems

Bilge Pumps

- Your boat is equipped with impeller-type bilge pumps, which are used to pump water out of the bilge.
- Bilge pumps are controlled by automatic bilge pump float switches (autofloat switches) and/or switches at the helm.
- Automatic bilge pumps are wired directly to the battery so they will function even when the boat is completely shut down and left unattended.

NOTICE

Discharge of oil, oil waste or fuel into navigable waters is prohibited by law. Violators are subject to legal action by the local authorities.

Bilge Pump Testing

Bilge pumps should be tested often to verify they are working properly. To test a bilge pump, activate the dash-mounted switch and verify that water in the bilge is being pumped overboard. If bilge water is present and the pump motor is running but NOT pumping, inspect the discharge hose for a kink or collapsed area. If no problems are found, check the bilge pump housing for clogging debris as follows:

To check for clogging debris:

- Remove the power cartridge:
 - Lift the tab while rotating the fins counterclockwise.
 - Lift out the power cartridge.
 - Clear debris from the outer housing.
- Reinstall the power cartridge:
 - Make sure the "O" ring is properly seated.
 - Coat the "O" ring with a light film of vegetable or mineral oil.
 - Align the two cams on either side of the power cartridge with the two slots on the outer housing and press the power cartridge into the housing while twisting clockwise.
- Ensure proper reinstallation by attempting to twist the fins counterclockwise without lifting the tab. The cartridge should stay in place.

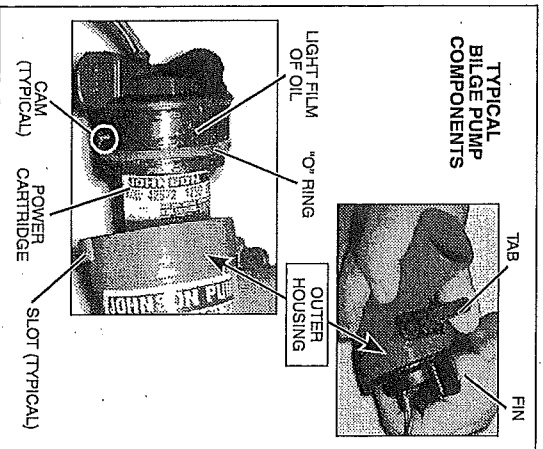

Autofloat Switches

Automatic bilge pumps use electromagnetic float (autofloat) switches to automatically activate the pump whenever water accumulates above a preset level in the bilge. One autofloat switch is mounted next to the bilge pump; it activates, and is wired directly to the battery so it will function even when the boat is completely shut down and left unattended.

Autofloat switches should be tested often for proper operation as follows:

- Push the float switch test button UP to activate the bilge pump.
 - If the pump does NOT turn on, check the inline fuse. If the fuse is good but the switch doesn't work, it may indicate a bad switch or possibly a low battery.
- Push the test button all the way DOWN to return the float switch back into the auto mode.

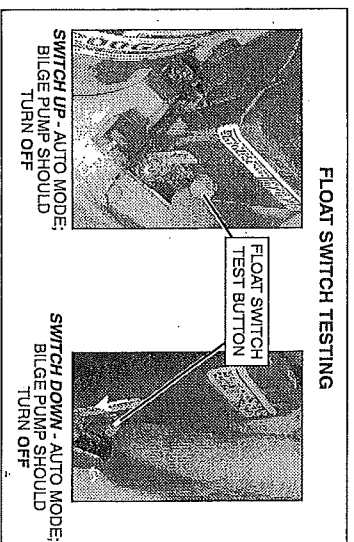

CAUTION!

When the float switch test is completed, you MUST push the test button all the way DOWN to return the switch back into auto mode!

Fuel System

Carefully read the fuel system sections of the owner's manual and the engine operation manual.

NOTICE

Discharge of fuel into navigable waters is prohibited by law. Violators are subject to legal action by the local authorities.

WARNING!

FIRE, EXPLOSION AND OPEN FLAME HAZARD!

- It is very important that the fuel system be inspected thoroughly the first time it is filled and at each subsequent filling.
- The fueling instructions in the owner's manual and the fuel grade recommendations in the engine operation manual must be followed.

CAUTION!

Avoid the storage or handling of gear near the fuel lines, fittings and tank.

Fuel Fill Location

The fuel fill receptacle is located on the starboard aft deck of your boat and is labeled "GAS". If you experience difficulty when filling the fuel tank, check to see that the fuel fill and vent lines are free of obstructions and kinks.

Fuel Quality

- Refer to your engine manual for fuel grade recommendations.
- Make sure your fuel suppliers are reputable and can be relied upon to furnish clean, high quality fuel. Once you have found such suppliers, keep your tank as full as possible with their fuel (allowing for expansion due to temperature variations). Then, if you are forced to add a potentially poor quality fuel supply to the tank, the portion of poor quality fuel will be minimized.
- Consult your selling dealer or local marina about recommended fuel additives that help prevent fungus or buildup inside the fuel tank.

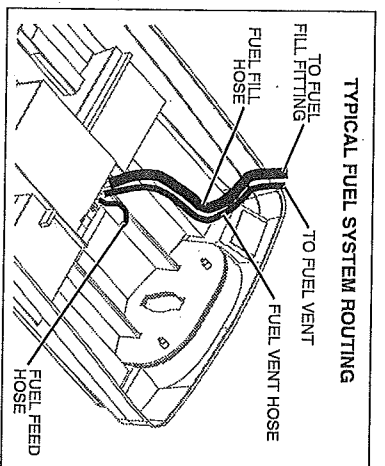

Anti-siphon Valves

Your boat may feature anti-siphon valves, which are an integral part of the fuel line barb fitting on gas fuel tanks. Anti-siphon valves are spring loaded and are opened by fuel pump vacuum. In the unlikely event of a fuel line rupturing, the anti-siphon valve is designed to prevent the siphoning of fuel from the tank.

! WARNING!

FIRE/EXPLOSION HAZARD! If an engine problem is caused by fuel starvation, check the anti-siphon valve. If the valve is stuck or clogged, shut down the engine and replace it. Except in an emergency, NEVER operate the engines without the anti-siphon valve.

Freshwater Systems

- A pressure-demand (cold only) freshwater system comes standard-equipped on the 2659 and is an option on the 2109, 2159 and 2459 Rendezvous models.
- We strongly recommend that you fill the water tank at every opportunity to avoid the possibility of running short of potable water.
 - Water filters installed in your freshwater system should be inspected and cleaned often.
 - When your boat is to be left unattended for long periods of time, pump the water tank dry to prevent stored water from becoming stagnant and distasteful. Should it become necessary to disinfect the freshwater system, ask your dealer about treatments that are available for your boat's system.
 - The water pump switch should be turned OFF whenever the boat is not in use or whenever the water tank is empty.

Transom Shower

If your boat features a freshwater transom shower, the water pump switch MUST be activated before using the transom shower. Be sure to read the manufacturer's operating instructions, provided in your boat's owner's packet.

Live Well System (Option)

- Your boat may come equipped with an optional live well (not available on all boats), which may be used to hold live fish or bait.
- The aerator pump installed in the live well system is used to pump a continuous supply of oxygenated raw water into the live well. The switch for the aerator pump can be found at the dash. Occasionally check the aerator pump when it is operating to verify that it is pumping adequate amounts of water. If there appears to be a problem, check the system (including the intake strainer) for weeds or other debris.
 - Overflow raw water is automatically drained overboard.
 - To drain live wells that are gravity-drained, remove the stand pipe and allow water to drain completely.

NOTICE

The live well pump should be shut OFF whenever underway at planing speeds.

Live Well Routing (Typical)

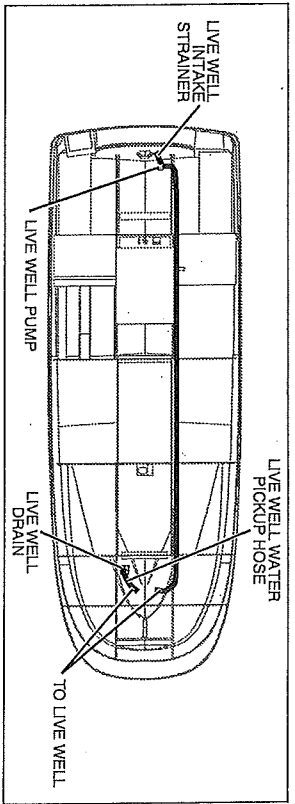

Portable Head

Your boat features a portable head (toilet), we recommend that you carefully read and follow the manufacturer's operating instructions supplied in your boat's owner's packet.

NOTICE

Check with local authorities for regulations regarding the legal use of marine head systems.

Deck Equipment

Trolling Motor (Option)

Your boat may be equipped with an optional trolling motor. Detailed operating instructions can be found in the manufacturer's manual. We strongly recommend that you thoroughly read these instructions before using the trolling motor for the first time.

Pedestal Seat

If your boat features a removable pedestal seat, remove the seat and stow it in a safe and secure area while underway or when trailering your boat.

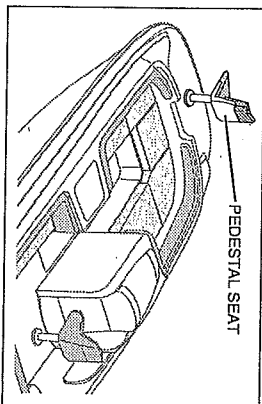

! DANGER!

PERSONAL INJURY HAZARD! NEVER occupy the pedestal seat while your boat is underway. Sitting on the pedestal seat while the boat is underway is especially hazardous and WILL cause personal injury or death.

Canvas Installation

The installation of canvas is intended to be a two person job.

Aft Bimini Top Installation

1. Lay the bimini top across the transom with the stanchions pointing forward. The port side of the top has four mounting stanchions.
2. With one person working on each side of the boat, remove the locking pins from the middle deck hinges (point A).
3. Install the eye-end of the main stanchion (B) between the lobes of the deck hinge.
4. Reinsert the pin and make sure it goes all the way through and locks. The main stanchion (B) is the longest stanchion on both sides.
5. Raise the bimini top.
6. While one person holds the top upright, the second person attaches the port and starboard aft corner stanchions (C) and (D) to the corner deck hinges.
7. Attach the port rear cross brace (E) to it's deck hinge.
8. Remove the canvas storage boot from the bimini top.
9. Unfold the bimini top forward and pin the forward stanchions (G) and (F) to their deck hinges.
10. Stow the boot.

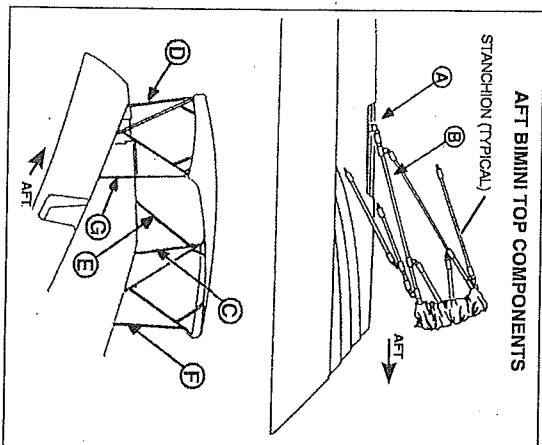

Forward Bimini Top Installation (Option)

1. Lay the bimini top across the transom with the stanchions pointing forward. The bowed-in (forward) stanchions should be on top.
2. Separate the front bow assembly (see point A below) from the canvas by unzipping the main bow pocket (B) and the forward center bow pocket (C). With one person working on each side of the boat, remove the locking pins from the forward deck hinges (D).
3. Install the end eyes (E) of the forward bow stanchions between the lobes of the deck hinge.
4. Reinsert the pin and make sure it goes all the way through and locks.
5. Remove the locking pins from the aft deck hinges (F).
6. Install the end eyes (G) of the aft bow stanchions between the lobes of the deck hinges.
7. Reinsert the pin and make sure it goes all the way through and locks.
8. Remove the bimini top boot and store.
9. Pull the canvas forward, over the forward bow assembly and zip the main stanchion (H) into the forward bow pocket (B).
10. Zip the forward center bow braces (I) as needed to tighten the canvas.

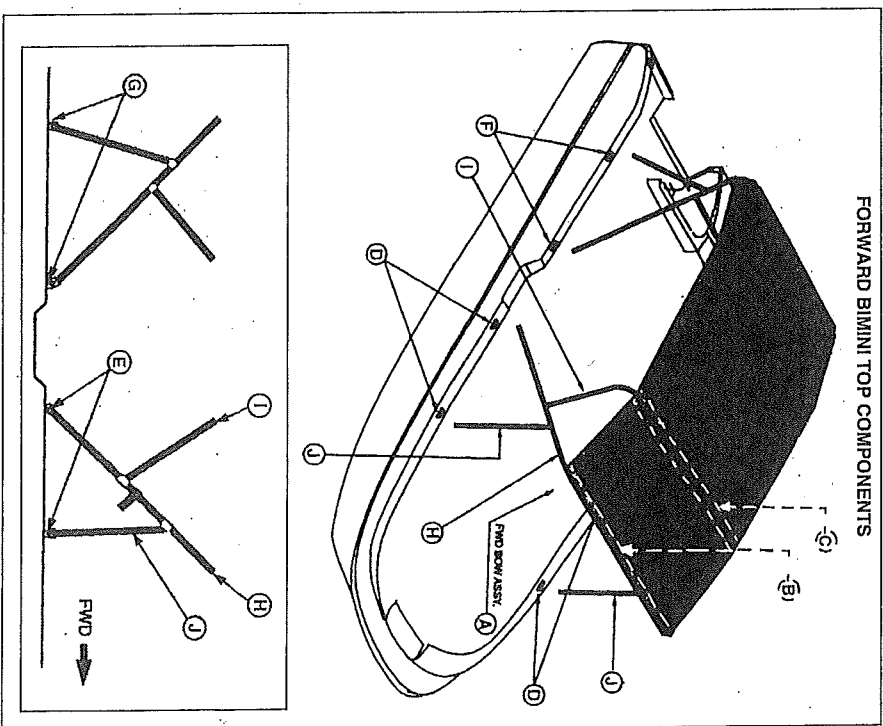

CHAPTER 4: SYSTEM DIAGRAMS

2109 (GF)

Hullside Hardware & Drains

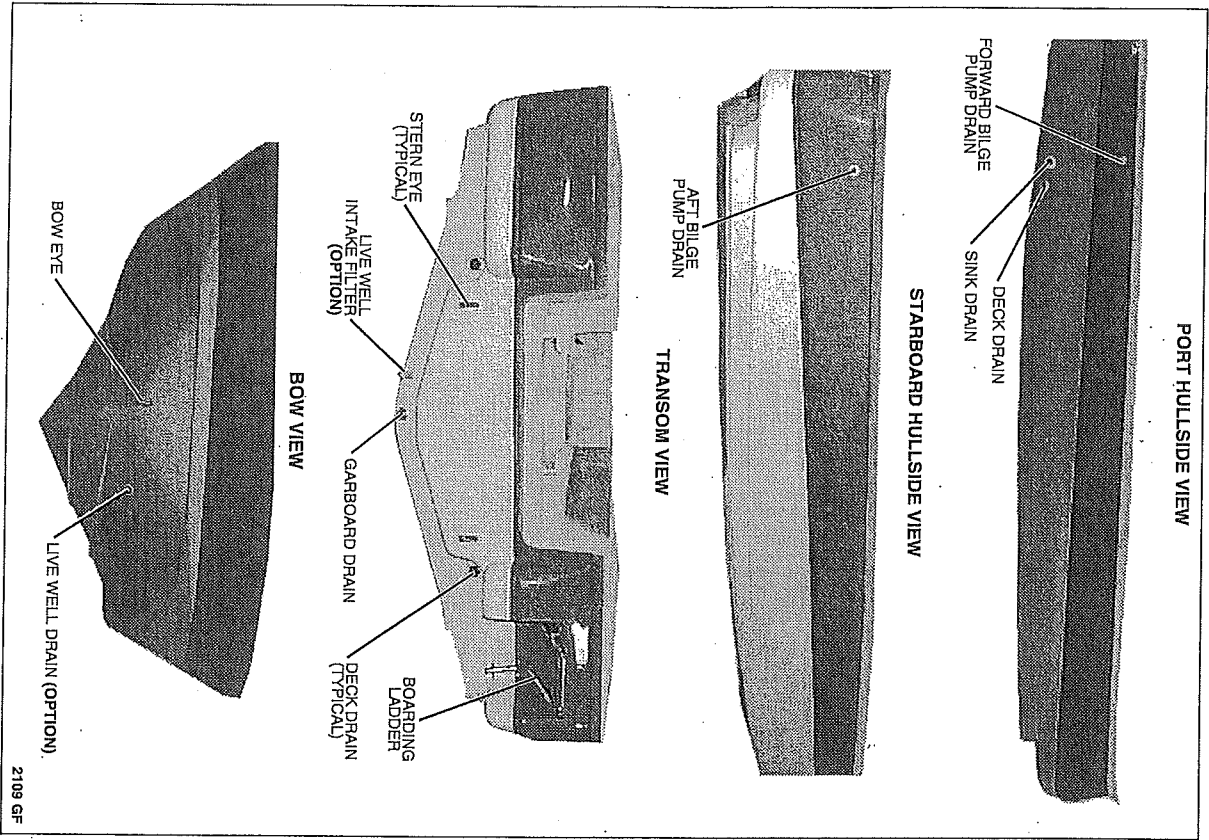

Bilge Pump Routing

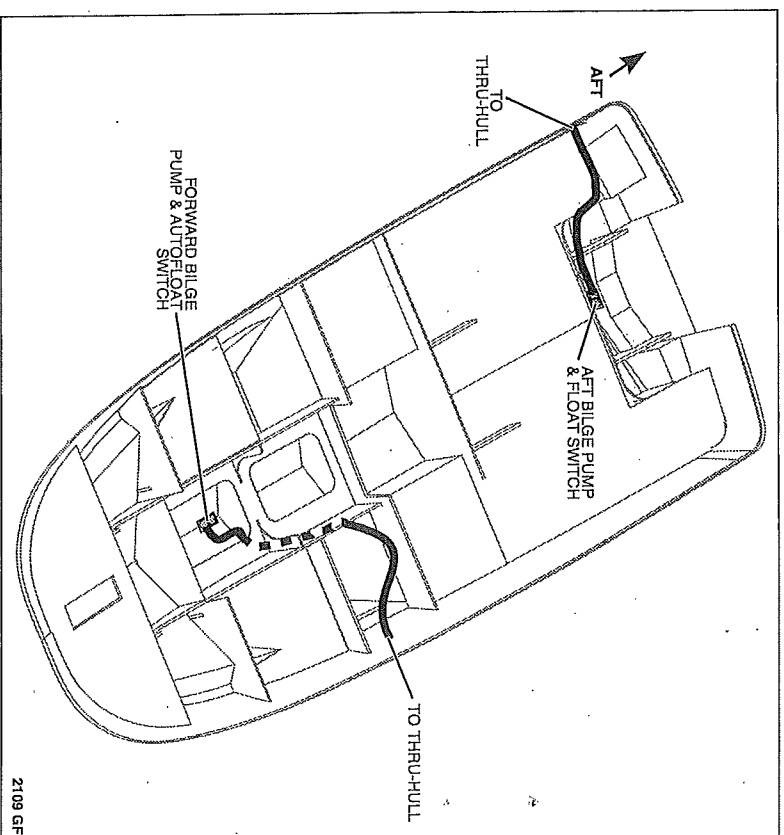

Steering & Shifter Cable Routings

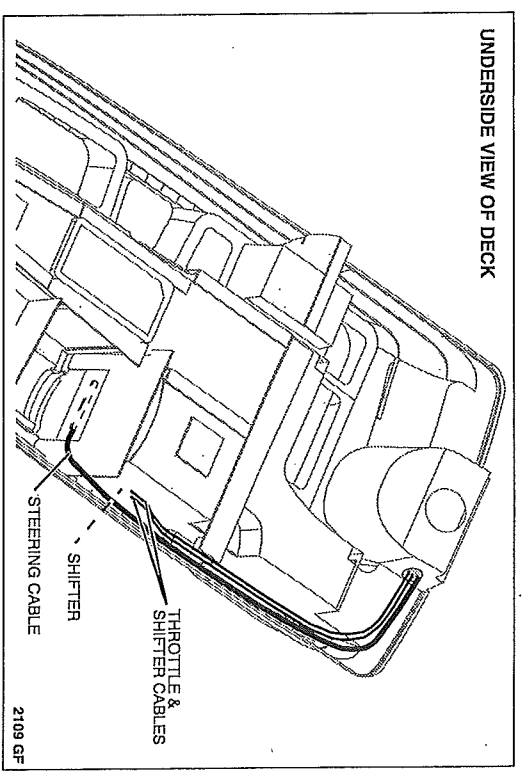

Electrical Routings

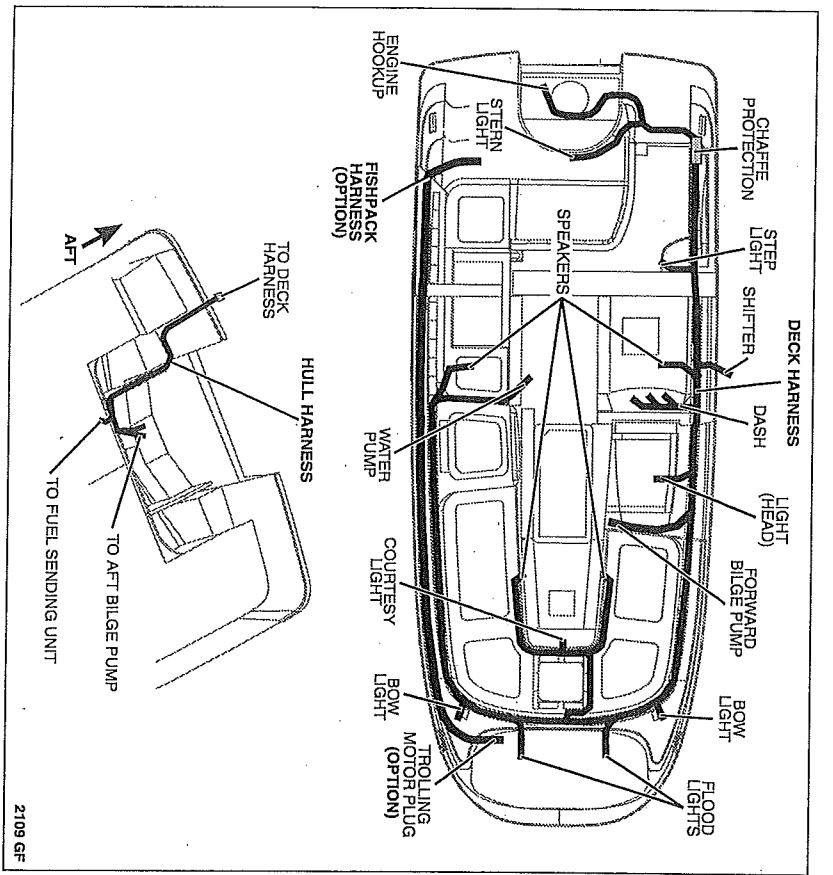

Freshwater System Routing (Option)

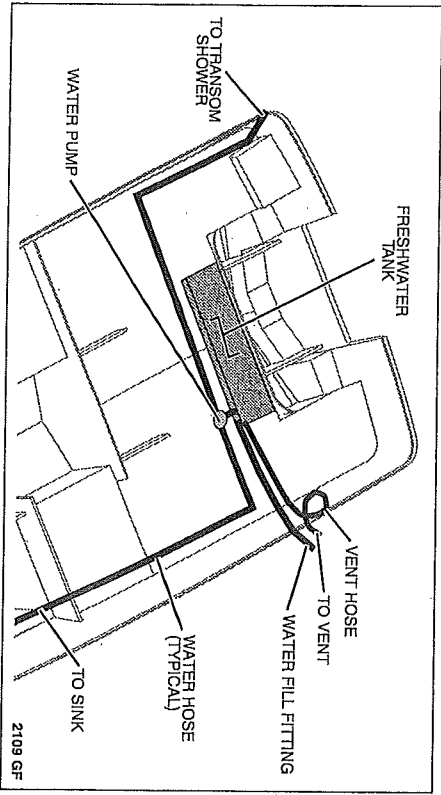

2159 (GH)

Hullside Drains & Hardware

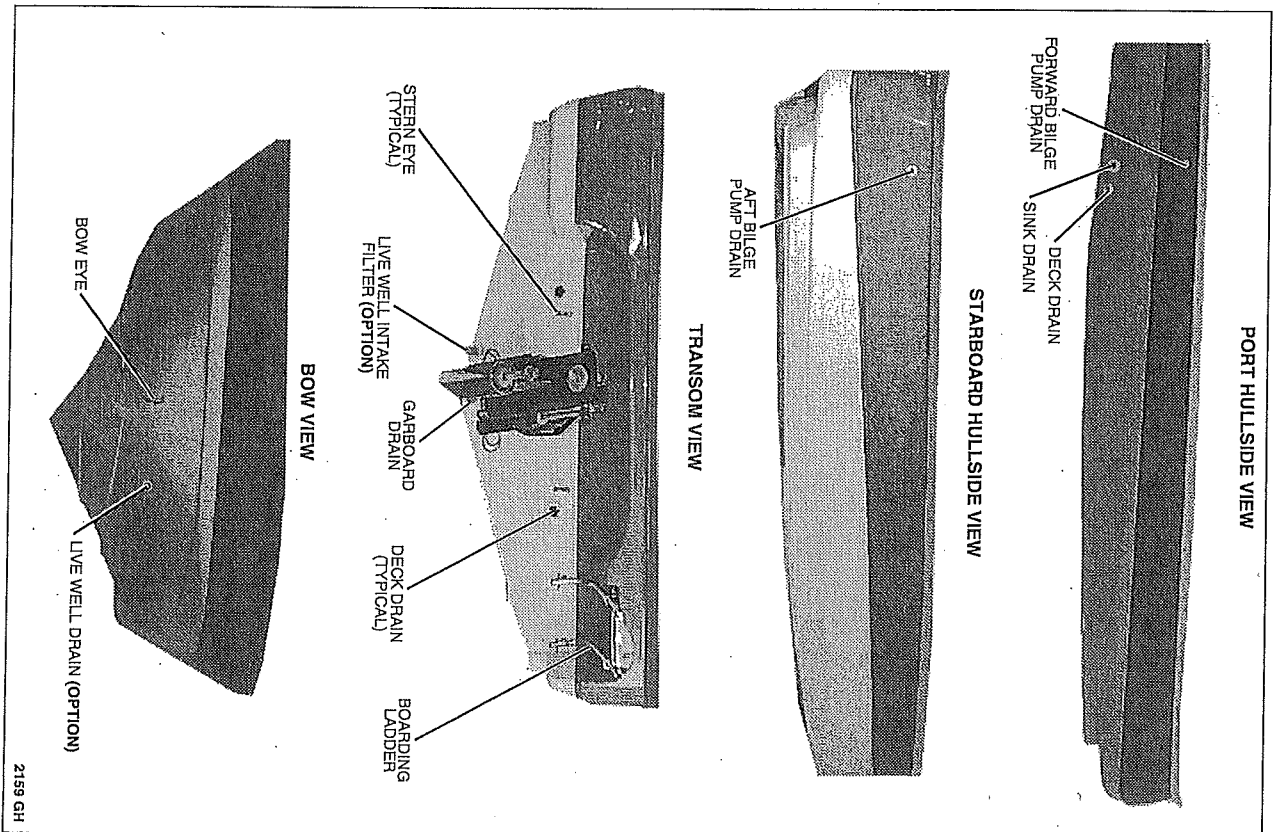

Bilge Pump Routing

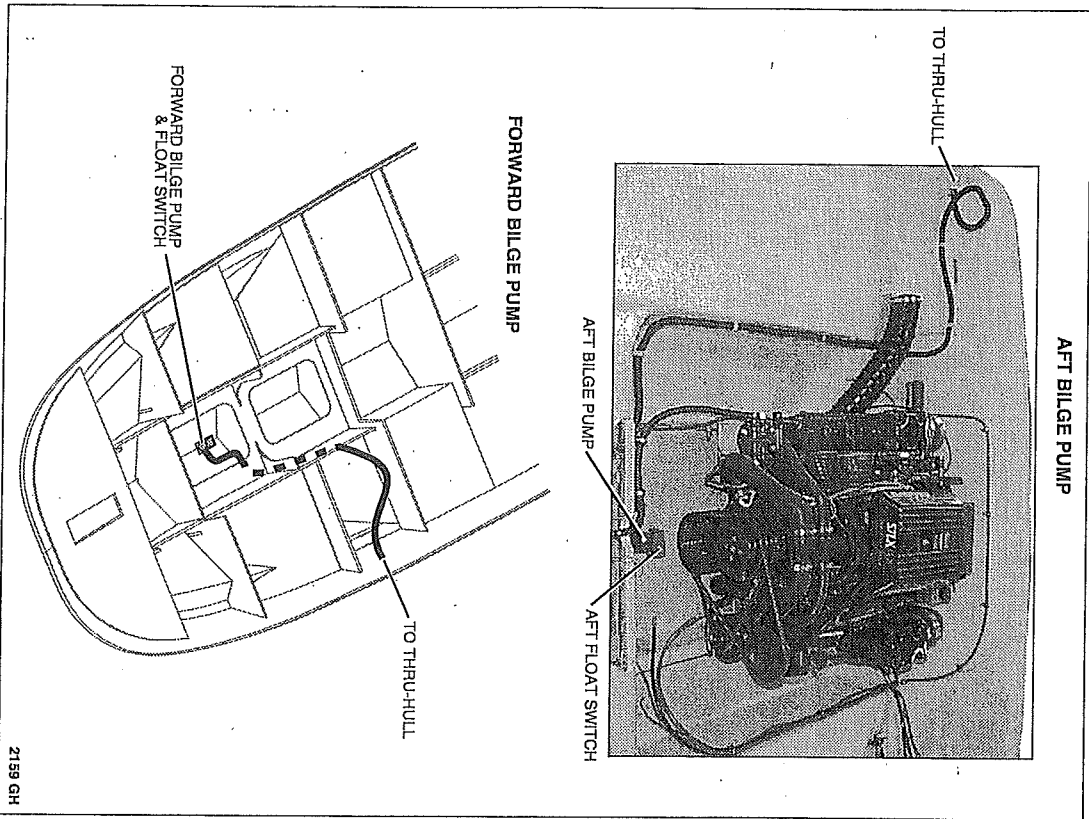

Freshwater System Routing (Option)

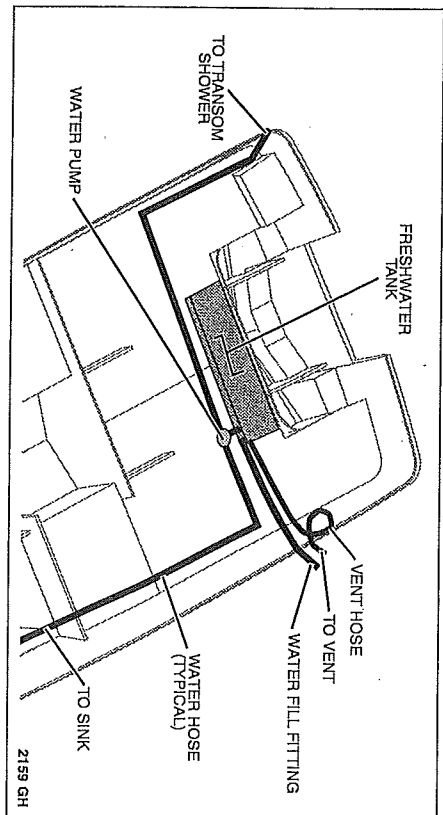

Steering & Shifter Cable Routing

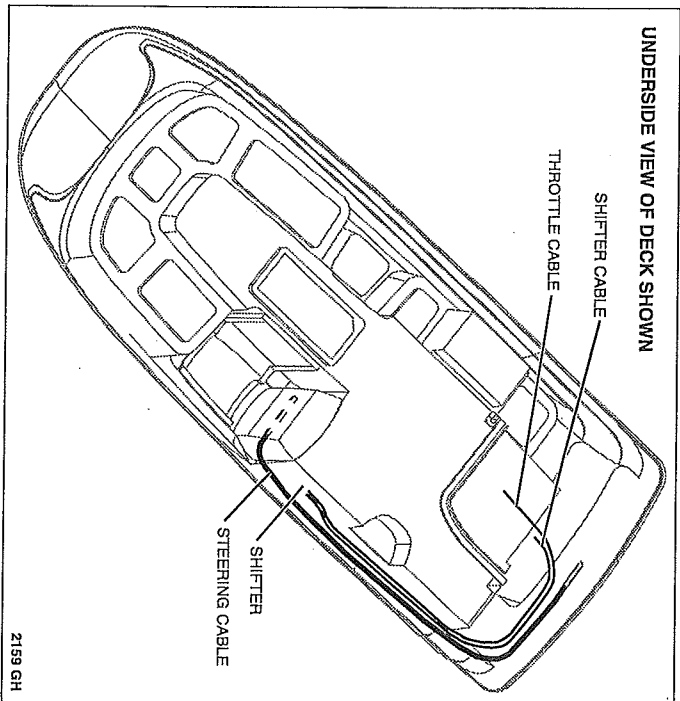

Electrical Harness Routing

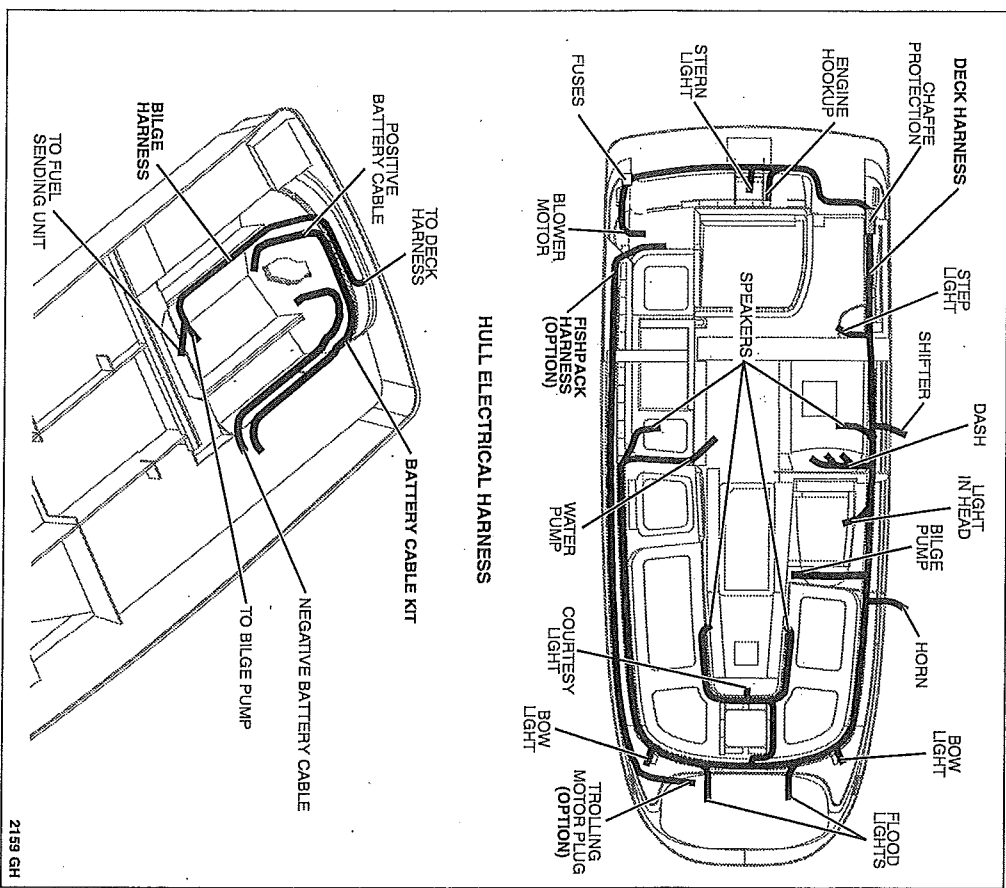

2459 (GB)

Hullside hardware & Drain Locations

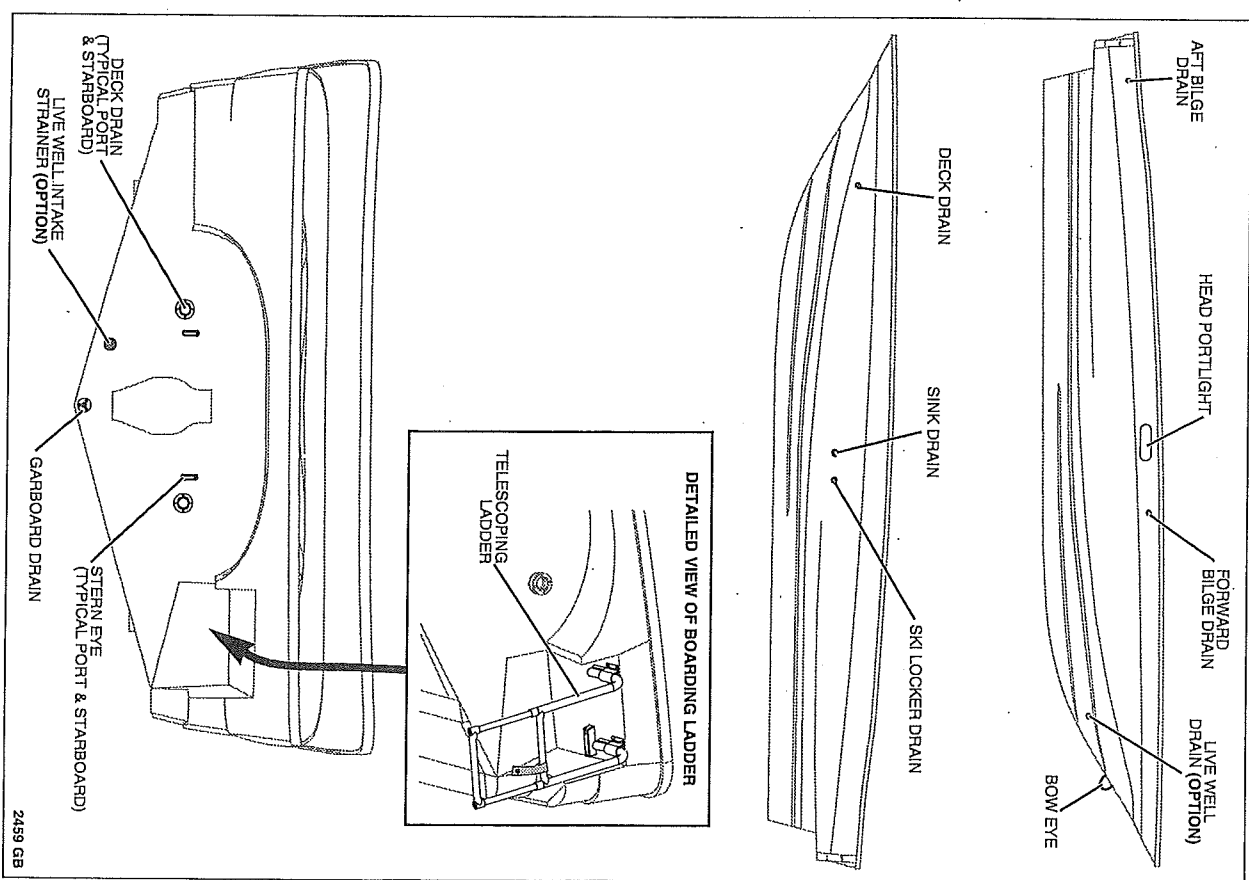

Bilge Pump Routing

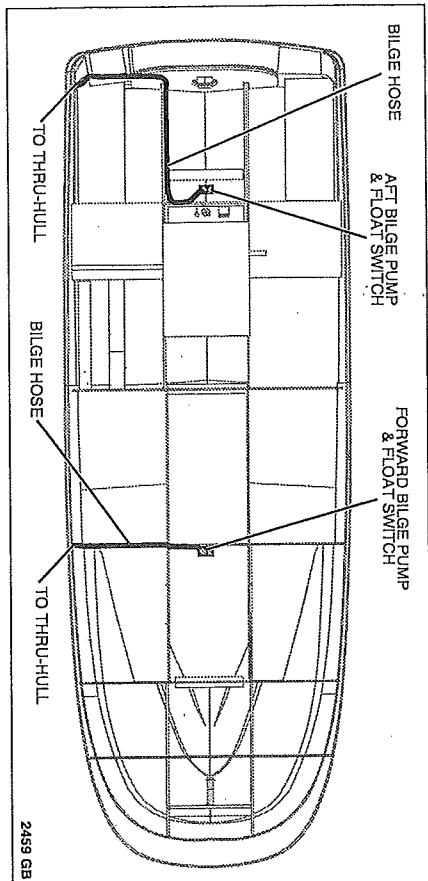

2459 GB

Freshwater System Routing

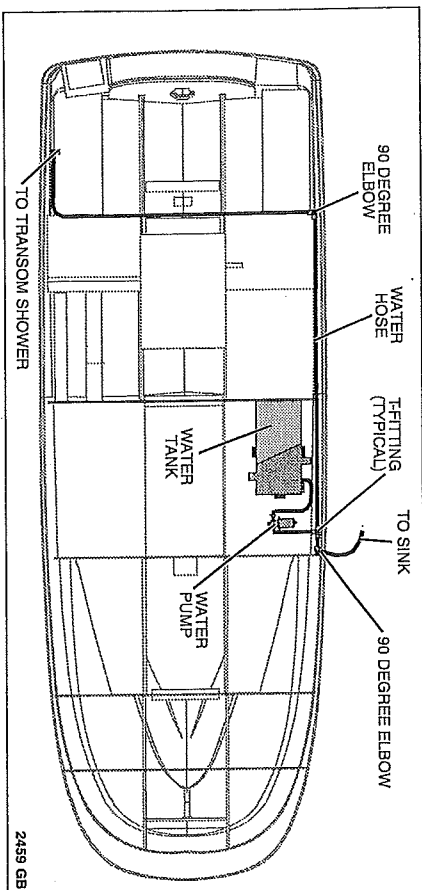

2459 GB

Electrical Harness Routings

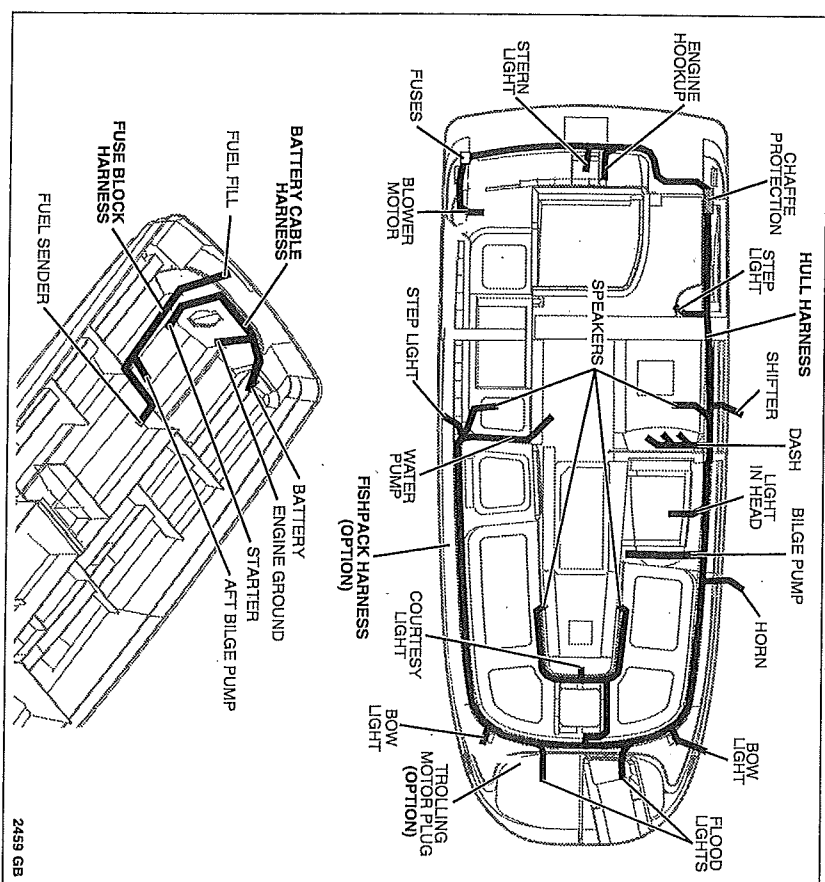

2459 GB

Aft Cockpit

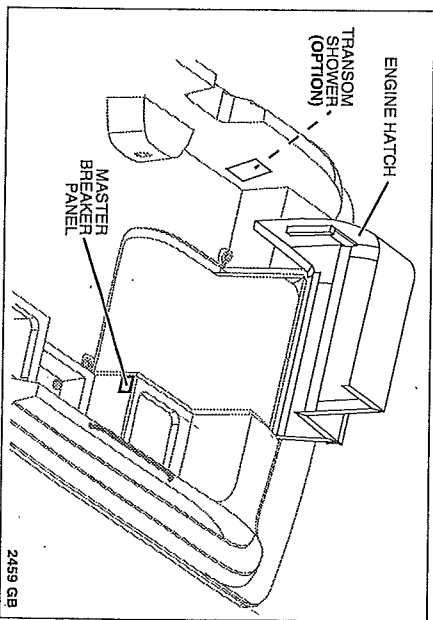

2459 GB

Deck Fill & Pump-out Fittings

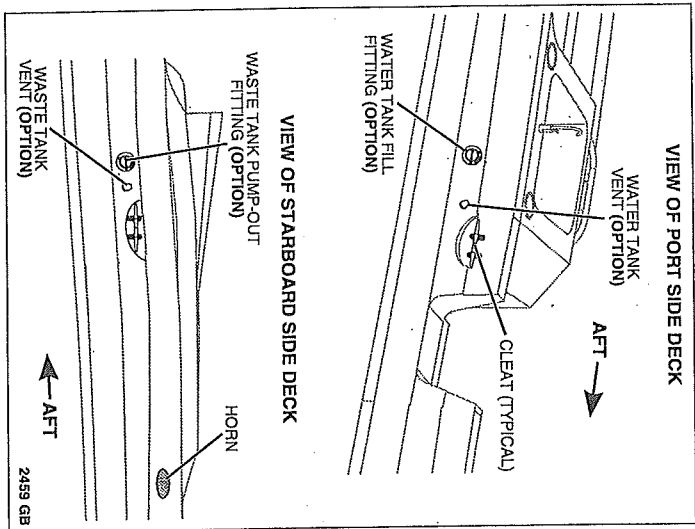

Transom Hardware

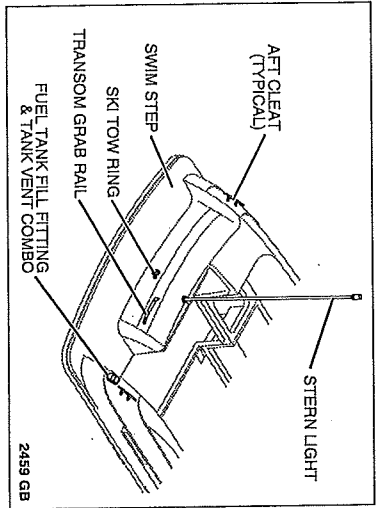

2659 (GD)

Hull Exterior Hardware

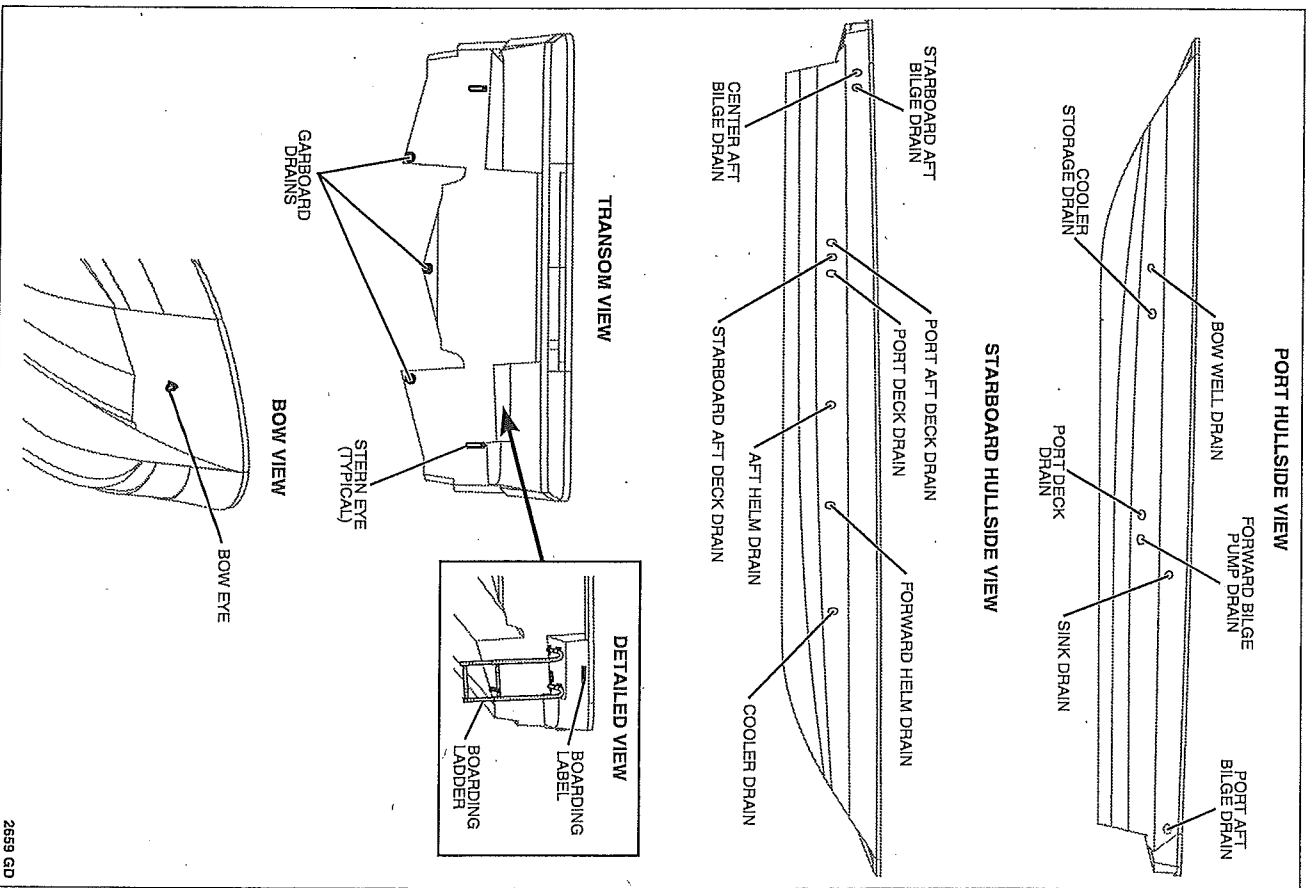

Freshwater System Routing

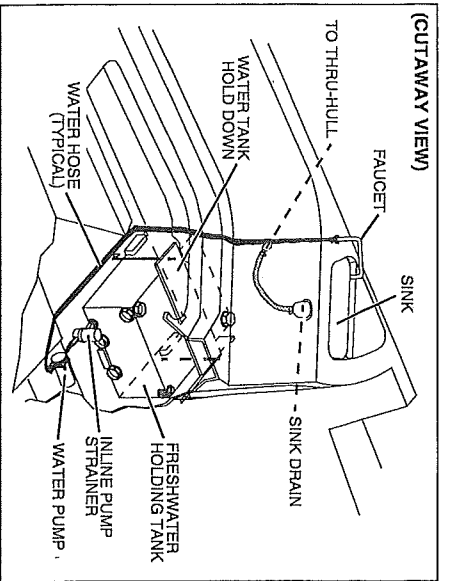

Electrical Harness Routings

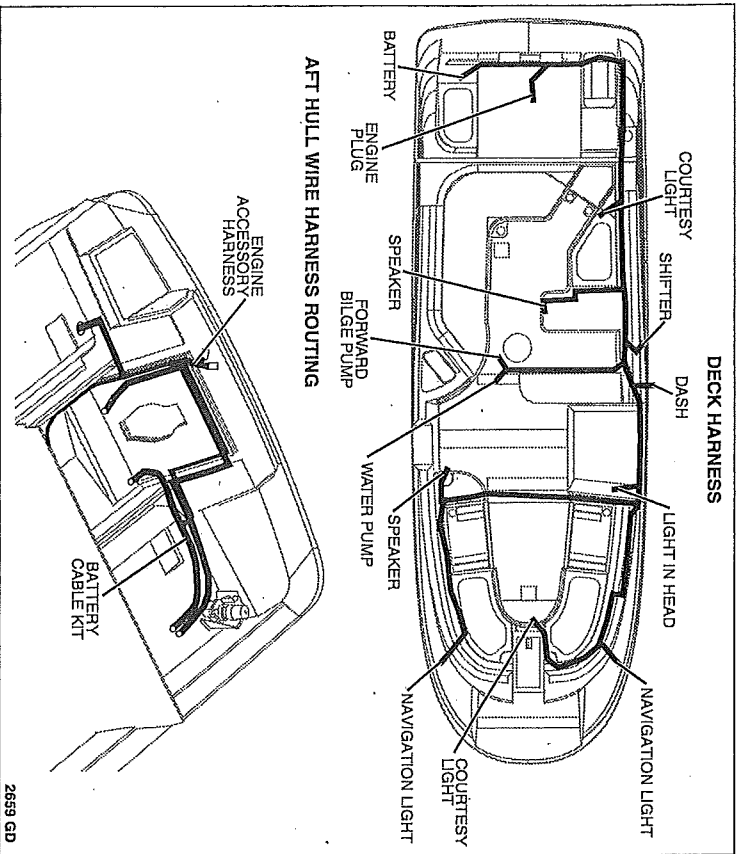

Bilge Pump Routings

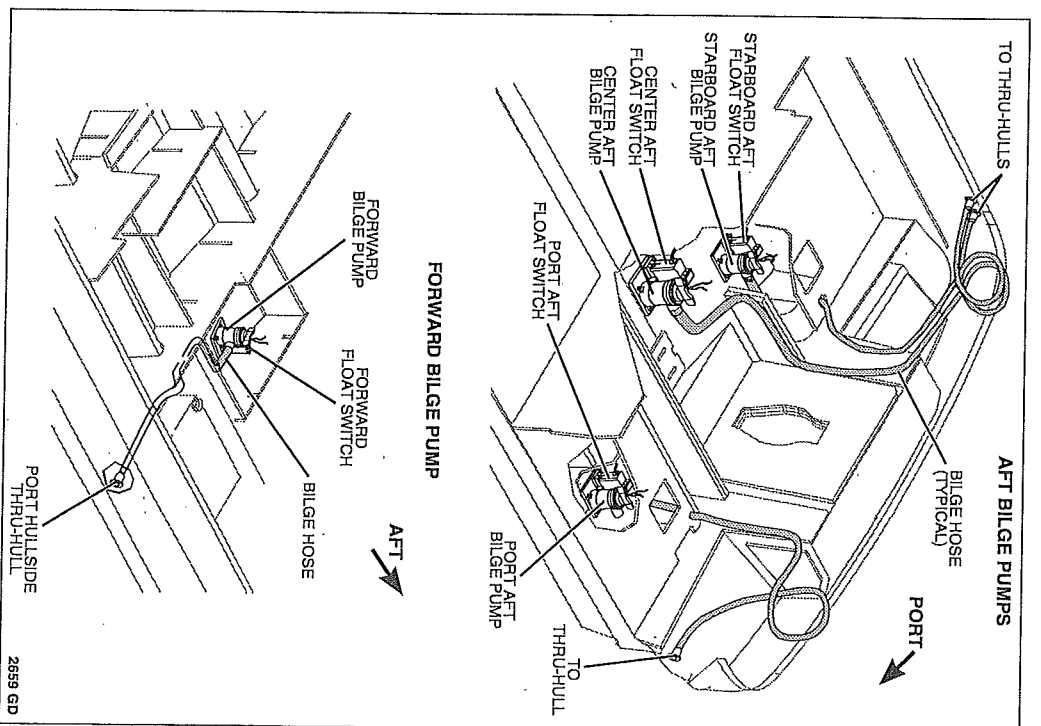

CHAPTER 5: WIRING SCHEMATICS

Key to Electrical Symbols

Symbol	Description	Symbol	Description
	Connection (Node)		Gauge
	No Connection		Ammeter
	Battery		Frequency Meter
	Earth Ground: Represents a black conductor that is the same size as the colored conductor		12 Volt DC Receptacle
	Breaker		Voltmeter
	Breaker		Motor/Pump
	Fuse		Speaker/Horn/Alarm
	Switch: Single Pole Single Throw (SPST)		Float Switch
	Switch: Double Pole Single Throw (DPST)		Plug
	Lighted Switch: Single Pole Single Throw (SPST)		Fuel Sender
	Momentary Switch		Diode
	Incandescent Lamp		Current Transformer
	Neon Lamp		Solenoid

Wire Color Key

Color Key	Description	Color Key	Description	Color Key	Description	Color Key	Description
B, BLK	Black	G, GR, GRN	Green	R, RED	Red		
BL, BLU	Blue	LT	Light	T, TAN	Tan		
BR, BRN	Brown	O, OR, ORG	Orange	W, WH, WHT	White		
DK	Dark	PK	Pink	Y, YEL	Yellow		
GY, GRV	Gray	PU, PUR, PPL	Purple				

NOTICE

- Wiring diagrams show optional equipment not installed on all models.
- Some boats equipped with a stereo may have silver (-) and copper (+) colored speaker wires or red/black (-) and red/white (+) port speaker wire colors; green/black (-) and green/white (+) starboard speaker wire colors.

BRP LINER® Engine/Accessory Harnesses 2109 (GF)

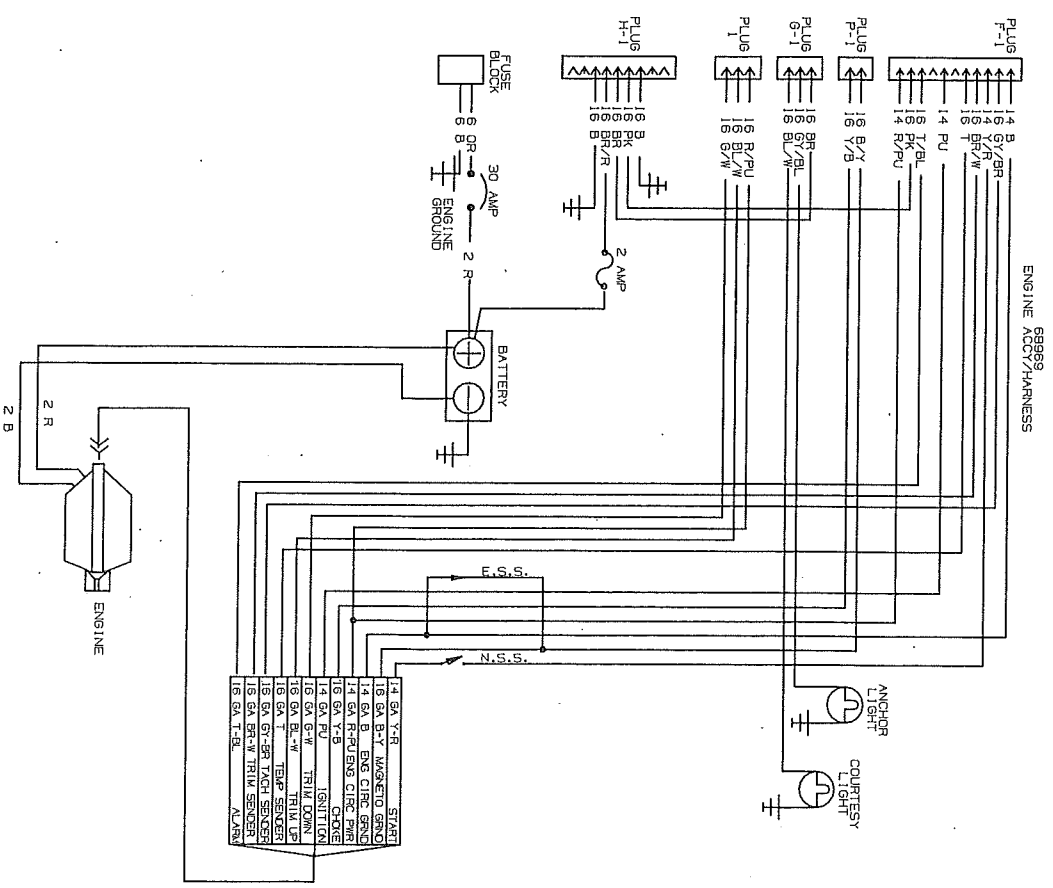

2159 (GH) & 2459 (GB)

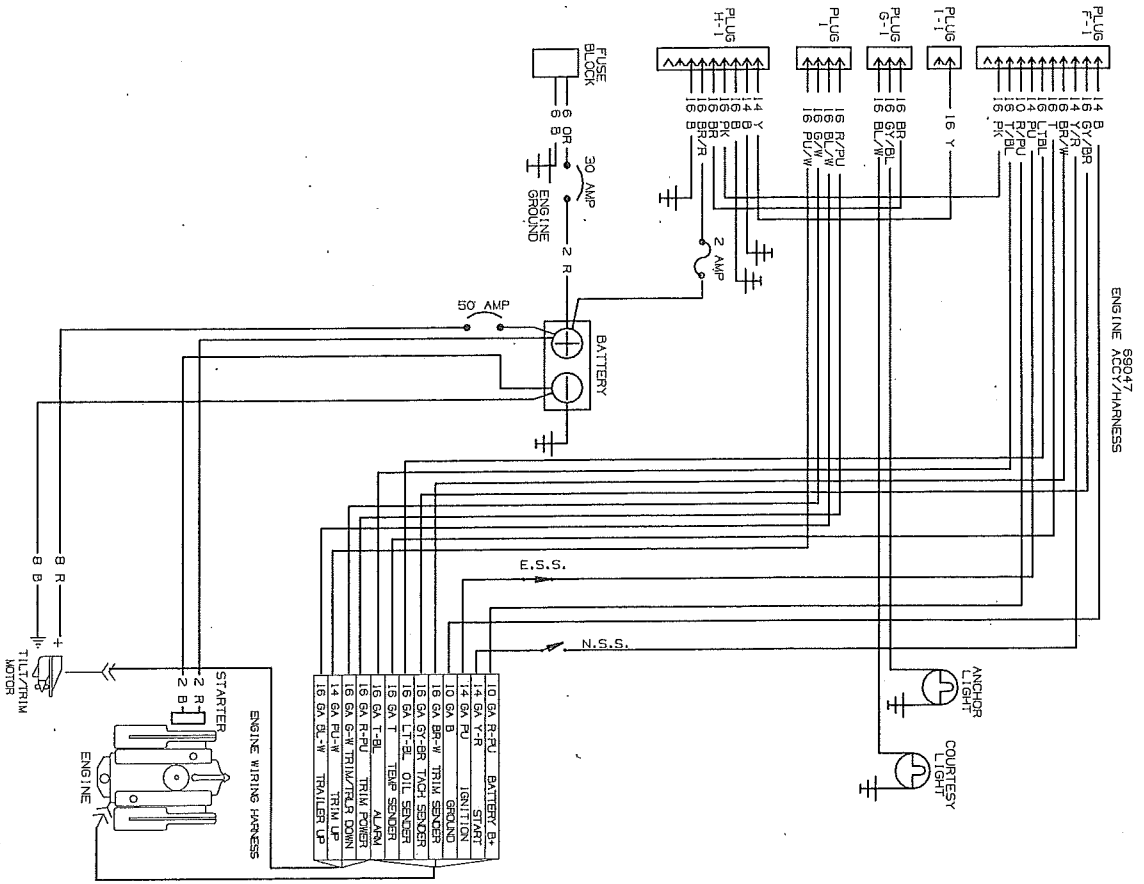

2659 (GD), Part 1 of 2

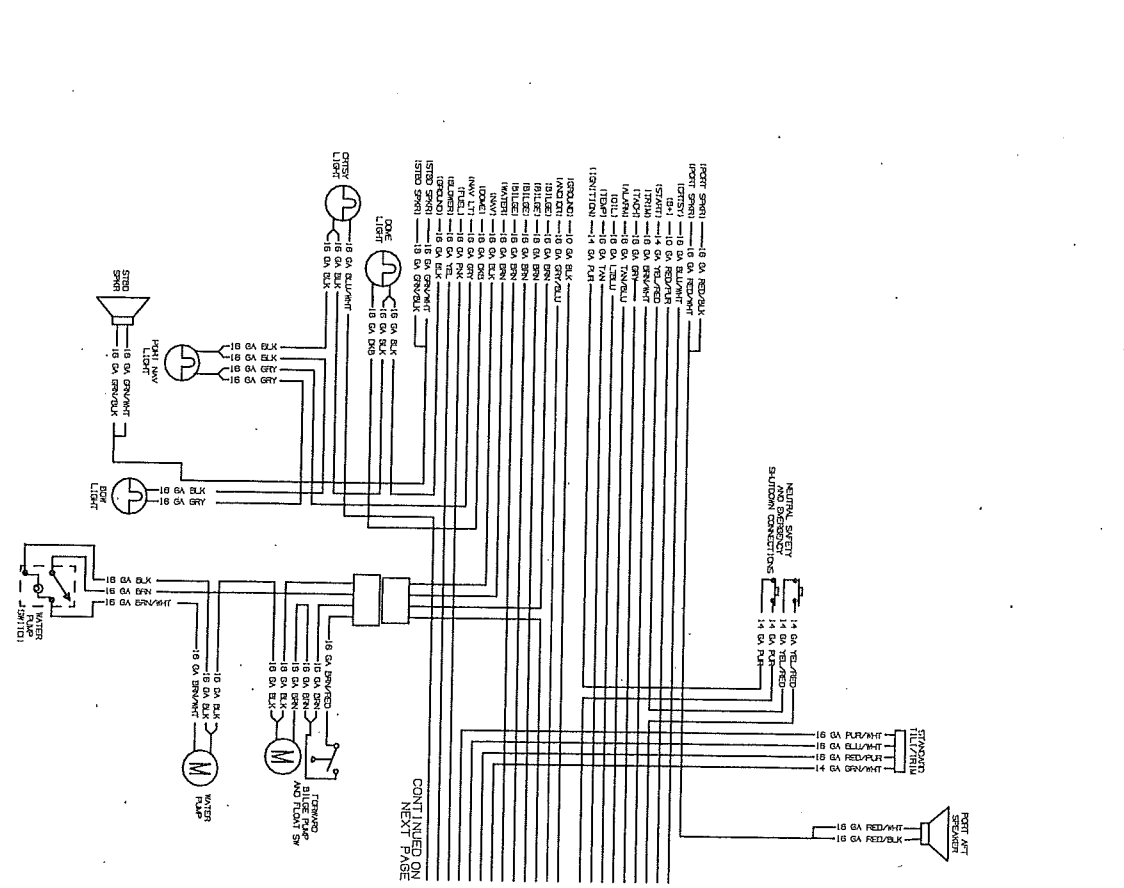

2659 (GD), Part 2 of 2

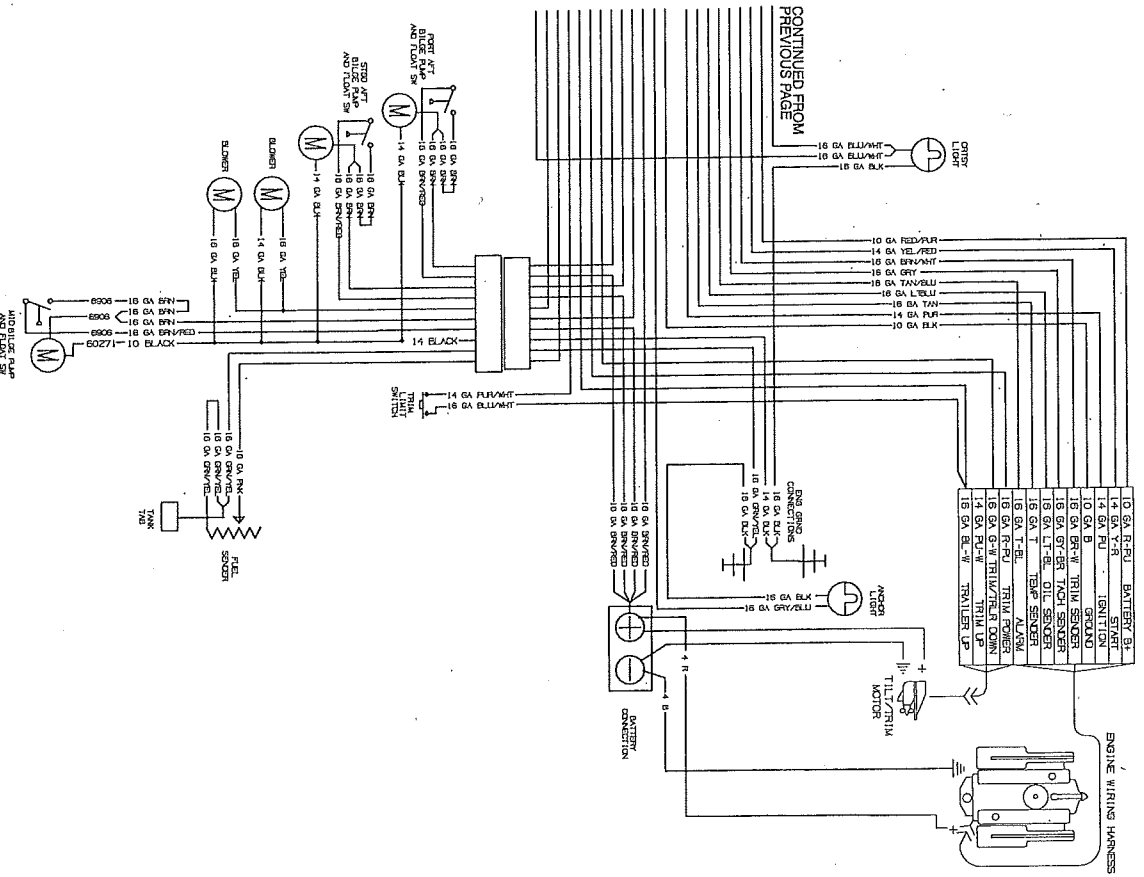

Deck Harnesses

2109 (GF) & 2159 (GH)

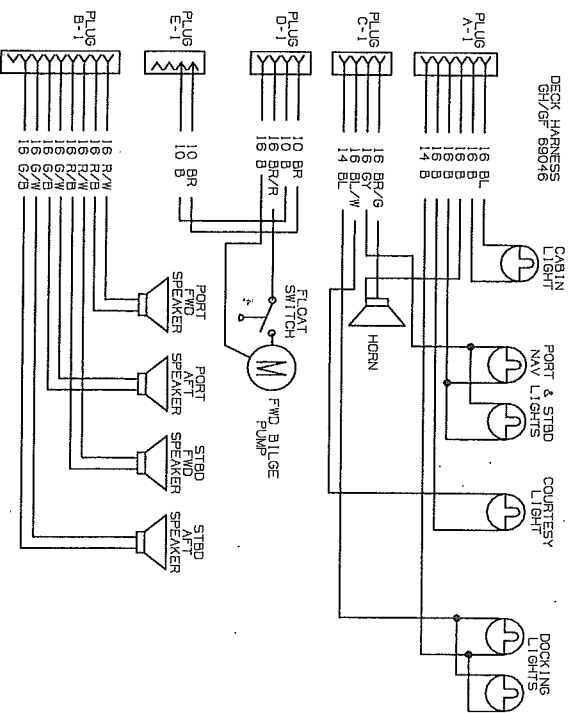

2459 (GB) & 2659 (GD)

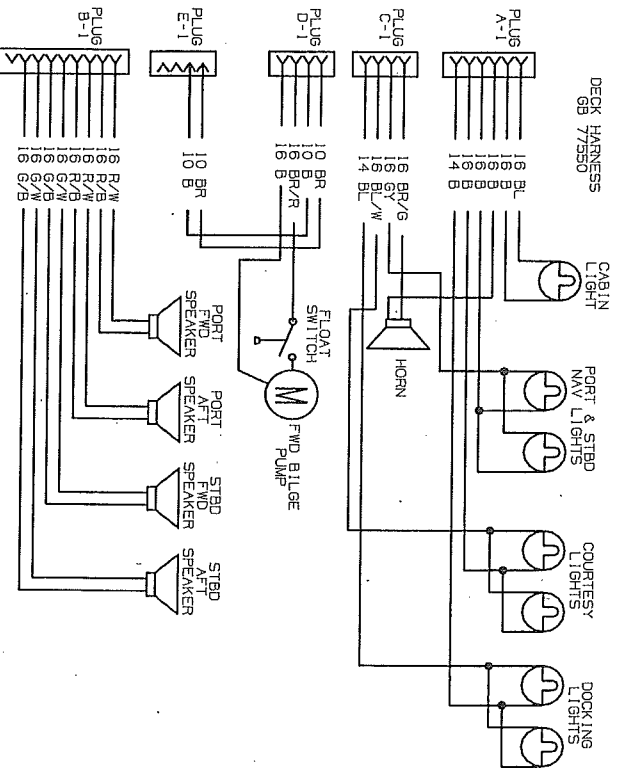

Bilge Harness

2109 (GF), 2159 (GH), 2459 (GB) & 2659 (GD)

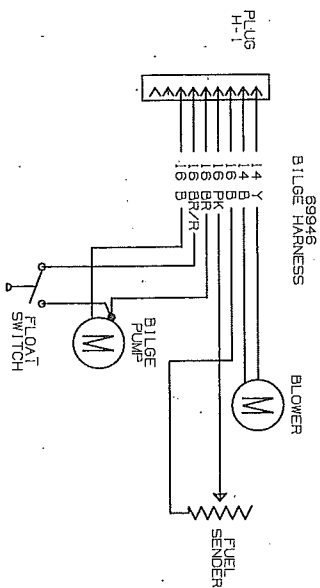

Trolling Motor Harness

2109 (GF), 2159 (GH), 2459 (GB) & 2659 (GD)

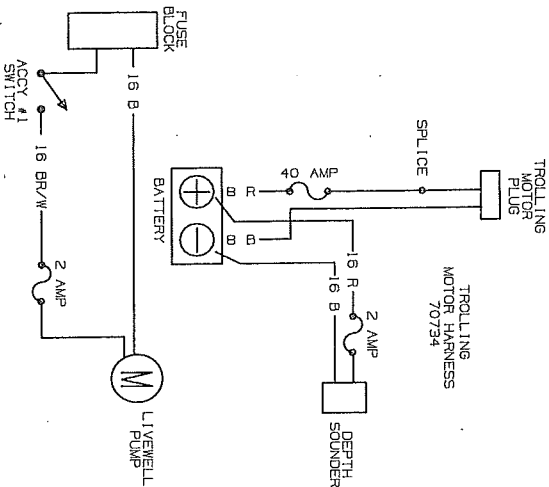

Water Pump Harness

2109 (GF), 2159 (GH), 2459 (GB) & 2659 (GD)

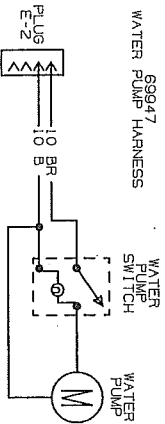

Rendezvous Owner's Manual Supplement

Fuse Block Harness

2109 (GF), 2159 (GH), 2459 (GB) & 2659 (GD)

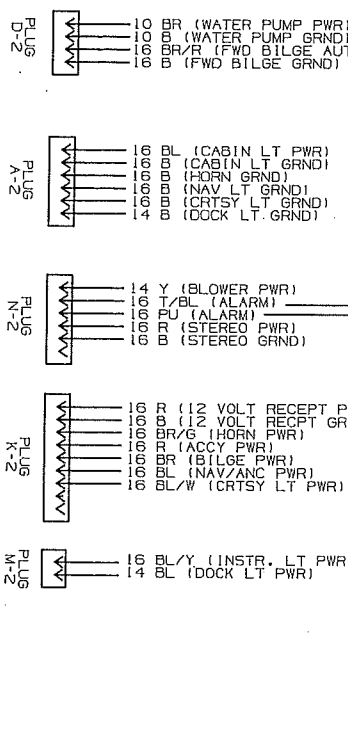
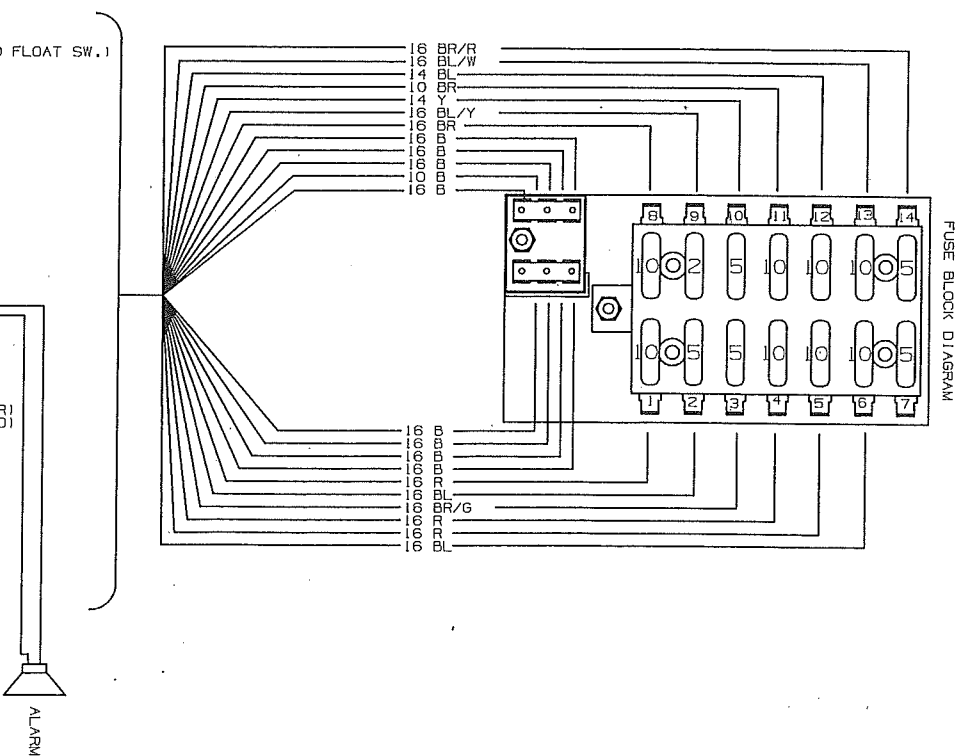

Rendezvous Owner's Manual Supplement

