

QUANTUM

OWNER'S MANUAL

QUANTUM HAS YOUR FISHING BOAT PRIORITIES RIGHT.

Welcome Aboard

This manual has been prepared to assist you in the operation and care of your Quantum boat. Please read through it completely, as familiarization with its contents can contribute to the more effective operation of your boat.

Your Quantum boat is part of a carefully engineered full-value package. It has been paired with a motor and trailer designed to provide optimum performance and utility. Please be aware that any changes you might make to this boat, motor and trailer combination may result in handling and performance qualities that differ from those experienced with the original package.

Your boat's mechanical and electrical systems were designed to meet safety standards in effect at the time the boat was constructed. Some of these standards were mandated by Federal law, others are considered industry norms. All of them were designed to insure your safety, and the safety of other people, vessels and property around you. To maintain the integrity and safety of your boat, only qualified people should perform maintenance on, or in any way modify, the steering system, engine control system, fuel system or electrical system. Failure to maintain these

systems as designed could violate Federal law, and could expose you and other people to the danger of bodily injury or accidental death. We recommend that you follow the instructions provided in this handbook, in the engine owner's manual, and in the accessory instruction sheets included with your boat, motor and trailer package. We also recommend that you perform the following steps:

1. Make certain that you receive a full explanation of all systems from the dealer before taking delivery of your boat.
2. Read this manual thoroughly, paying particular attention to the subjects of **fueling, checking for fumes, starting, carbon monoxide, loading limits, recommendations for safety, and warranty.**
3. Practice—all members of the family should be familiar with the operation and systems of your boat.
4. Participate in a safe boating course. Call the local office of the United States Power Squadrons or the United States Coast Guard Auxiliary for the date and location of their next class.

There is information in this manual related to the following **Quantum boats**:

1604 Fish and Ski

1704 Fish and Ski

1804 Fish and Ski

2004 Fish and Ski

Due to our ongoing commitment to product improvement, we reserve the right to change, without notice or other obligation, the specifications or other information contained in this publication.

WARNING! A qualified operator must be in control of the boat at all times. Do not operate your boat while under the influence of alcohol or drugs. Never operate your boat at speeds which exceed your ability to react if an emergency develops. At night, turn on the appropriate running lights and cruise at a reduced speed that will allow you plenty of time to avoid dangerous situations.

Table of Contents

PREPARATION

Recommendations for Safety	4
Safety Equipment	6
Tool Chest	7
Miscellaneous Items	7
Static Float Attitude	8
Other Tips	8

TRAILERING	8
-------------------------	---

OPERATING

Fueling Procedures	10
Fuel Capacity Table	11
Launching	11
Starting	12
Before You Leave	13
Maneuvering	13
Boat Performance	16
Boat Running Attitude	16
Instruments	17

COMPONENTS/SYSTEMS

Electrical System	17
Fuel Systems	19
Starter Motor	19
Bilge Pump	20
Running Lights	20
Transom Platforms	20
Livewells	21
Electric Trolling Motor	21
Ski Tow Posts	21
Pedestal Seats	21

GENERAL MAINTENANCE AND REPAIRS	22
--	----

Bilges/Engine	22
Cabin and Topside Areas	23
Hull	24

STORAGE	27
----------------------	----

NAUTICAL TERMS	28
-----------------------------	----

WIRING DIAGRAMS	29
------------------------------	----

WARRANTY	32
-----------------------	----

PREPARATION

Prior to leaving on your first outing (or, for that matter, any outing) there are certain items to check and activities to perform. Familiarize yourself with your boat while dockside, and consider the following suggestions:

Recommendations for Safety

1. Personal Flotation Devices:

One Coast Guard approved personal flotation device (PFD) of suitable size is required for each person aboard a recreational boat. New PFDs bearing Coast Guard approval are now identified as Types I, II, III, or IV.

Requirements for boats sixteen feet (16') or over in length: One (1) Type I, II, or III (wearable) PFD for each person on board, and one (1) Type IV (throwable) PFD in each boat.

Requirements for boats less than sixteen feet (16') in length: One (1) Type I, II, III, or IV PFD for each person on board.

2. Always have children wear PFDs. Always check those devices intended for young children for fit and performance in the water. Never hesitate to have "all hands" wear lifesaving devices whenever circumstances cause the slightest doubt about safety.
3. Do not overload or improperly load your boat. Maintain adequate freeboard at all times. Consider the sea conditions, the duration of the trip, the weather and the experience of the personnel on board. Do not allow anyone to ride on parts of the boat that were not designed for such use. Sitting up on seat backs, bow riding, gunwale riding, or lounging on forward sundeck cushions while underway can be especially hazardous.
4. Falls are the greatest cause of injury both afloat and ashore. Eliminate tripping hazards where possible, make conspicuous those that must remain, and require that everybody on board wear proper footwear.
5. Understand the meanings of navigation buoys, and never moor to one. (It is a Federal offense.)

6. Know the various distress signals. A recognized distress signal used on small boats is to slowly and repeatedly raise and lower the arms outstretched to each side.
7. Storm signals are for your information and safety. Learn them and be guided accordingly.
8. A special flag (red flag with a white diagonal stripe) flown from a boat or buoy means skin diving operations are underway nearby. Approach with caution and stay clear by at least 25 yards.
9. Be especially careful when operating in any area where there might be swimmers.
10. Watch your wake. It might capsize a small craft. You are responsible for damage caused by your wake. Pass through anchorages at a minimum speed.
11. Learn and abide by common boating "rules of the road".
12. Always have up-to-date charts of your cruising area on board.
13. Keep an alert lookout. Serious accidents have resulted from failure in this respect.
14. Always instruct at least one person on board in the rudiments of boat handling in case you are disabled or fall overboard.
15. Consider what action you would take under various emergency conditions such as a person overboard, fog, fire, a damaged hull or other bad leaks, motor breakdown, severe storm or collision.
16. If your boat ever capsizes, remember that if it continues to float, it is usually best to remain with it. You are more easily located by a search plane or boat.
17. Keep firefighting and lifesaving equipment in good condition and readily available at all times.
18. Do not test fire extinguishers by squirting small amounts of the agent. The extinguisher might not work when needed. Always follow approved instructions when checking fire extinguishers.
19. Have an adequate anchor and sufficient line (at least six times the depth of the water) to assure a

secure hold in all types of weather and sea conditions.

20. Boat hooks are valuable when docking or when needed to retrieve objects that have fallen overboard.
21. Keep electrical equipment and wiring in good condition. No knife switches or other arcing devices should be installed in fuel compartments. Allow ample ventilation around batteries.
22. Good housekeeping in your boat is important. Cleanliness diminishes the probability of fire.
23. Know your fuel tank capacity and cruising range. If it is necessary to carry additional fuel, do so only in proper containers. Take special precautions to prevent the accumulation of fuel vapors in confined spaces.
24. Before departing on a boat trip, advise a responsible friend or relative about where you intend to cruise. Be sure to give that person a good description of your boat. Keep them advised of any changes in your cruise plans. These precautions will enable your friend or relative to tell the

Coast Guard where to search for you and what type of boat to look for if you fail to return. Be sure to advise the same person when you complete your trip to prevent any false alarms about your safety.

25. Your local United States Coast Guard Auxiliary and the United States Power Squadrons offer safe boating classes several times a year. These are comprehensive courses and are generally of minimal cost to you. Call your local U.S. Coast Guard Auxiliary or Power Squadron Flotilla for the time and place of their next class.

Safety Equipment

The following safety-related items should be considered as part of your standard equipment:

1. Fire extinguishers (correct number and type, located for easy access)
2. Personal flotation devices
3. Fenders, lines and boat hook
4. Flares (night and day type)

5. Flashlight(s) with extra batteries
6. Charts of your intended cruising area
7. First aid kit

Tool Chest

1. Assorted screwdrivers (Phillips and flat blade)
2. Pliers (regular, vise-grip, and water pump)
3. Wrenches (box, open-end, allen, and adjustable)
4. Socket set (metric and U.S. standard)
5. Hacksaw with spare blades
6. Hammer
7. Battery jumper cables
8. Electrical tape
9. Assorted fasteners

10. Gear grease and penetrating oil
11. Feeler gauges

Miscellaneous Items

1. Engine and accessories manual
2. Spare propeller with fastening hardware
3. Extra V-belts
4. Engine lubricating oil
5. Spare fuel and oil filters
6. An extra cooling pump impeller
7. Portable fuel can
8. Replacement light bulbs
9. Spare set of spark plugs and other ignition parts

Static Float Attitude

The static floating attitude of your boat can be affected by many variables. Optional equipment and loading of gear are the biggest contributors to a boat's list. After launching, the floating attitude of any new boat can be adjusted. If your boat lists to one side, load heavy items on the opposite side until the boat floats more level. Load the remainder of your gear evenly after that.

Other Tips

1. When commissioning a new boat, do not plan an extensive trip or party until you have had a shakedown cruise to make sure all equipment on your boat is functioning properly and you are familiar with its operation.
2. Use big fenders or fender boards to protect your boat's hull whenever mooring next to floats, piers, or other boats.
3. Carry plenty of line that is properly sized to your boat. We suggest at least two 30' lengths of 3/8" nylon line.

TRAILERING

An Escort trailer, specifically designed for your Quantum boat, should be used for trailering your boat. Use of any other trailer requires careful checking to insure that capacity and support points are correct.

1. Before using your trailer, read the trailer owner's manual thoroughly.
2. Check your trailer's brakes for proper operation prior to departure on each trip. (Consult your state laws for trailer brake requirements and equip your trailer accordingly.)
3. Frequently check your trailer's wheel lug nuts for security.
4. Check the tires for proper inflation. Underinflated tires heat up rapidly and tire damage is likely to occur.
5. Wheel bearings should be checked at least every 90 days and before putting your boat away for the season.

6. Make it a habit to check the wheel hubs every time you stop for gas or refreshments. If the hub feels abnormally hot, the bearings should be inspected before continuing.
7. On extended trips, carry spare wheel bearings, seals and races.
8. Check to be sure the taillights and turn signals work when attached to the towing vehicle. Some automobiles require heavy duty flasher units to make turn signals work properly.
9. Check your trailer's springs and undercarriage for loose parts.
10. Your boat should be fastened to the trailer by a line from the bow eye to the winch, PLUS a safety chain or cable from the bow eye to the winch stand or trailer tongue. The stern of your boat should be tied down to the trailer from the stern eyes.
11. Too much or too little tongue weight will cause difficult steering and tow vehicle sway. A rough rule of thumb is that 5% to 10% of the boat and trailer weight should rest on the tongue.
12. Close and secure all cabin windows and doors. Store all loose equipment so that it cannot slide or fall.
13. Before towing your boat, take down the convertible top, side curtains and back cover. Canvas tops are not designed to withstand the loads created by highway speeds.
14. Carry a spare wheel and tire, along with the tools needed to change them.
15. Before backing your trailer into the water, disconnect the light plug from the car. This will greatly reduce the chance of blowing out your trailer lights when they become submerged.

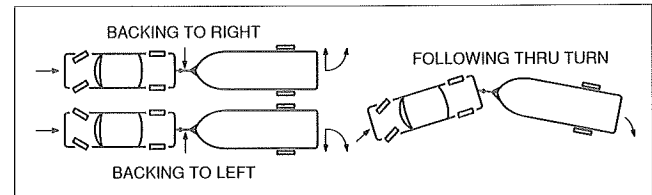

PRACTICE—PRACTICE—PRACTICE

Before attempting that first launch, tow your boat to a nearby empty parking lot and practice backing your trailer. Whenever you are backing up, be sure to have a lookout to help direct you.

Make sure your outboard or outdrive unit is raised to clear obstacles.

If it is not already so equipped, consider installing a right side mirror on your tow vehicle.

When rounding sharp turns, remember to swing wide to avoid cutting the corner with the trailer.

OPERATING

Fueling Procedures

WARNING! Fuel vapors are explosive and can become trapped in the lower portions of a boat. While fueling, all doors, hatches, and portlights must be closed.

WARNING! Do not use fuels that incorporate any form of alcohol or alcohol derivatives. Alcohol destroys marine fuel system hoses and components, which could cause hazardous leaks, fire or explosion.

Internal "Built-In" Fuel Tanks

1. If you're going to fuel your boat while it's in the water, be sure it's securely moored to the dock.
2. Turn off all electrical equipment including engines, appliances, bilge blower, lights, etc.
3. Extinguish all cigarettes, cigars or other items that may produce a spark or flame.
4. Close all openings including hatches, windows, doors, and portlights.
5. Through-deck fittings are provided for fuel tank filling. Remove the cap and insert the fuel supply nozzle, allowing the nozzle to maintain contact with the fitting; this will prevent possible static sparking.

6. Allow for thermal expansion of the fuel on very hot days. Do not fill the fuel tank completely.
7. If, when filling the tank, you can't put fuel in at a reasonable rate, check the fuel vent line to see that it's not kinked or plugged.
8. When you have finished fueling, replace the fill cap and wash off any fuel spillage.
9. Inspect the bilge, both visually and by smell, for fuel fumes or leakage. Any sign of fuel leakage, or any indication of fumes, must be investigated and corrected prior to starting the engine.

Portable Fuel Tanks

1. Remove the tanks from the boat for filling.
2. Follow the instructions in the engine manual for the proper ratio and type of lubricating oil to be mixed with the gas.
3. Before placing the tank back in the boat, wash off any spilled fuel.

4. Note: Some portable tanks have vent screws which must be open during engine operation.

FUEL CAPACITY TABLE

Model	Tank Capacity (Gallons)
1604 Fish and Ski	12
1704 Fish and Ski	24
1804 Fish and Ski	24
2004 Fish and Ski	24

Launching

1. Your Quantum powerboat is equipped with a transom drain plug. Make sure this plug is tightly in place.

WARNING! Failure to install the drain plug securely will result in the boat filling with water when it is launched.

2. Once your boat is in the water, immediately board it and inspect the lower compartments for signs of leakage.

3. If any leaks are noted, immediately remove the boat from the water. The selling dealer should be notified so the leaks may be repaired before relaunching the boat.

Starting

The engine operating and maintenance manual furnished with your boat describes prestart and starting procedures. The following notes are basic reminders, and are not intended to cover every detail of starting. We urge you to thoroughly read and understand your engine manual.

1. Check the lubricating and cooling fluid levels.
2. Visually check for fuel, oil, coolant, and exhaust leaks.
3. Make sure the emergency engine shutdown switch cap is in place and the lanyard is attached to the operator.

WARNING! A serious accident can occur if the emergency engine shutoff switch lanyard is not fastened to the boat operator. In order for the emergency engine shutdown system to operate correctly, the lanyard must be physically attached to the operator (around the wrist or securely fastened to a stout piece of clothing, such as a belt, etc.).

WARNING! Gasoline vapors are highly explosive. To prevent a possible explosion and fire, check the engine and fuel compartments before each engine start for fumes or accumulation of fuel.

4. **Do not** continuously operate the starter for more than 15 seconds at a time. Allow at least three minutes for cooling between start attempts.
5. On boats so equipped, check the voltmeter and temperature gauges immediately after the engine starts.
6. Check the steering operation by turning the steering wheel full port and starboard while observing the outboard or outdrive movement.

7. While the boat is still securely moored to the dock, advance the shift control to forward, to reverse, and into neutral to check the shifting operation.

WARNING! Carbon monoxide is a poisonous gas that is colorless, odorless and heavier than air. Idling at the dock for long periods of time, or running your boat without adequate ventilation can result in dangerous accumulations of carbon monoxide gas inside the boat. Always ventilate the boat when operating the engine.

Before You Leave

Provided you have not encountered any problems, you are almost ready to go. (If you did encounter problems, do not attempt to operate your boat until they are corrected.) Before you leave, perform the following steps:

1. Check the operation of equipment such as bilge pumps, running lights, wipers, radios, etc.
2. Instruct passengers in the use and location of flotation devices and fire extinguishers.

3. Obtain a reliable weather forecast and plan accordingly for everyone's comfort and safety.
4. Notify a responsible friend or relative of your cruise plans. Upon your return or a change in your cruise schedule, notify that person again in order to avoid unnecessary concern.

Maneuvering

With all of your predeparture checks now completed, you are ready to leave the dock.

Basic Maneuvering

Remember that all boats steer by the stern (the feeling is much like steering your automobile in reverse). For example, when you turn the steering wheel to the left, the stern of the boat will swing to the right as the boat goes into a left turn. This is especially important to keep in mind when docking, or when operating in close quarters with other boats.

There are no brakes on a boat. Stopping is accomplished by allowing the boat to slow down (under 5 mph) and then putting the engine in reverse. Gently increasing reverse power will allow you to stop the

boat in a very short distance. A boat does not respond to steering in reverse nearly as well as it does when going forward, so do not expect to accomplish tight turning maneuvers when backing up.

Once you are away from the dock, devote some time to learning how to maneuver.

- Practice docking by using an imaginary dock.
- Practice stopping and reversing.
- When operating in close quarters or docking, all maneuvering should be done at idle speed. Proceed with caution in congested areas.
- Gradually increase your speed. Get used to the boat before attempting any full throttle operation.

Docking

Preparation:

Proper docking requires preparation. Start by making sure you have adequate mooring gear, and that it is stowed correctly and ready for use. Your dealer is the best source for information concerning the amount and type of equipment you should carry.

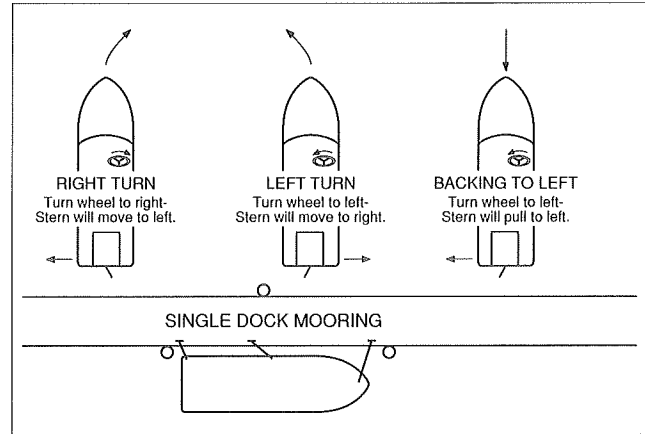

Approaching the Dock:

When approaching a mooring area, lower your speed within a reasonable distance to allow your wake to subside before it reaches other boats or docks. As you get close to your moorage, check for any wind or current action that may affect your maneuver; then make a conservative approach with these factors in mind. Try to use the elements to your advantage. Allow them to carry the boat into the dock. If there are high winds or strong currents, it is best to approach the moorage from the lee side. With a mild current and little or no wind, it is best to ap-

proach from the windward side. While approaching, check to see that all lines are attached to the cleats on the side facing the moorage. Also insure that fenders are lowered on that side. Be sure to check that the fenders are hung at the proper height.

As you approach your moorage, it is desirable to have one person at the bow and one at the stern of the boat, each with a boat hook and a mooring line attached to a cleat. Approach at idle RPM at an angle approximately 45 degrees to the dock. When the bow is within a few feet of the dock (starboard side), the stern can be brought alongside the moorage by turning hard to port. Next, turn to starboard and at idle RPM put the boat into reverse. This will stop the boat and bring the stern even closer to the dock. These steps are reversed for docking to port.

Mooring:

To attach lines to deck cleats, make a loop in one end of the line and pass it through the hole in the base of the cleat; then pass the loop back over the entire cleat. The line can now be used to secure your boat. Lines may be kept this way while underway as long as they are coiled and cannot become fouled in deck gear or props. In heavy sea conditions, all lines should be removed from the deck.

TIP: To tie up, run the line from your boat around the dock cleat and then back to your boat. This way you can untie the line without jumping from your deck to the dock and back again. Instead, just cast off one end of the line and bring the whole length back on board.

WARNING! Whenever you are towing another boat, or having your boat towed, make sure the towline is fastened securely to the bow or transom towing eyes only. Never attach a towline to deck cleats or the anchor windlass (if so equipped), as serious injury may result if the cleats or windlass pull free from the deck. Also, to reduce the danger created by a potential failure of the towline, everyone should stay well clear of the towline attachment points on both the towing and the towed boats.

Leaving the Dock:

Take into account wind, tide, current, and other forces that affect your maneuvering as you leave the dock. Most maneuvering to and from a dock is best accomplished at idle speeds.

Do not forget to release the mooring lines and stow the fenders.

When leaving a moorage on your starboard side and your bow cannot be pushed away from the dock first, start forward with the steering wheel turned to starboard for two or three feet. Then shift to reverse with steering full to port. Repeat if necessary to get the stern far enough away from the dock so you can back clear of any other boats that may be moored ahead of you. (Reverse steering wheel directions when leaving a dock located to port.)

Boat Performance

Boat speeds are affected by a great many factors. Some, such as temperature and altitude, you cannot change, but some factors you can:

1. Loading: Take only necessary equipment with you. Keep weight low in the boat and balanced.
2. Propeller: Keep it in good repair and at the correct pitch for your particular situation. The factory standard equipment propeller may not be the best for your particular boat and load conditions. If the engine RPM at full throttle is less than its maximum rating, try a prop of less pitch. If the engine RPM exceeds the maximum rating, try a prop of greater pitch.

A slightly bent or nicked propeller will adversely affect the performance of your boat.

3. Weeds, barnacles and other growth: Keep your boat's bottom clean. When your boat starts "growing grass", it will slow down greatly.

Boat Running Attitude

1. If your boat runs with its bow too high at cruising speeds, the following suggestions will help you achieve a more correct cruising attitude:
 - Move some weight forward in the boat.
 - Adjust the thrust angle of the engine (reduce the distance between the bottom of the transom and the drive unit). See your engine owner's manual for trimming instructions.
2. If your boat runs with its bow too low at cruising speeds (usually indicated by water coming off the hull far forward and steering difficulty or veering off course), you can raise the bow by performing steps opposite of those above.

Instruments

While under way, instruments should be checked frequently for possible indications of trouble.

1. *Tachometer*—A tachometer is an electrical instrument that indicates engine revolutions per minute (RPM). The tachometer is useful for monitoring engine speed to avoid exceeding the maximum RPM rating. In addition, it can be used to detect performance changes by comparing speedometer readings at various RPMs.
2. *Voltmeter*—Depending on which Quantum model you own, there may be either one or two voltmeters. One is mounted on the forward electrical panel for the electric trolling motor battery, and the other is on the instrument panel where it indicates the voltage of the main engine start battery. See “Electrical Systems” for proper voltage readings under a variety of conditions.
3. *Fuel Gauge*—The fuel gauge indicates fuel level. Since boats are exposed to rough water conditions and varying degrees of trim, fuel gauges may provide inaccurate readings at times. It is

always good to keep track of your running time as a double check against an inaccurate gauge.

4. *Compass*—Your boat may come equipped with a compass for use in marine navigation. Many factors affect the operation of your compass, such as local magnetic variation and deviation (induced needle deflection caused by metal components and the operation of electrical equipment aboard your boat). Each compass must be “swung” (compensated) to adjust for individual boat characteristics, and for the particular compass installation. It is vitally important, therefore, that you have your compass professionally swung before using it for marine navigation. Your Quantum dealer can refer you to local shops that perform this work.

COMPONENTS/SYSTEMS

Electrical Systems

WARNING! To reduce the risk of electric shock, only qualified personnel should install batteries and perform electrical system maintenance. You can minimize the danger of fire

and explosion by not exposing the batteries to open flame or sparks: It is also important that no one smoke anywhere near the batteries.

Although Quantum manufactures many different models of powerboats, the electrical systems on all models operate on the same basic theory:

1. *Battery:*

The key to a good marine electrical system is the battery. (The batteries are dealer-installed items.) Quantum makes the following recommendations on battery rating:

Outboard Models—minimum 70 amp/hour rating

On some models the condition of the battery can be read on the voltmeter when the ignition switch is in the ON position.

With the engine not running, voltmeter readings in the 11.5 to 12.5-volt range are considered normal. Readings in the 10 to 11.5-volt range indicate a marginal charge condition. Readings below 10 volts indicate a seriously discharged condition.

With the engine running (over 1500 rpm), voltmeter readings of 13 to 14 volts are considered normal. Readings below this indicate a severely discharged battery or a nonfunctioning charging system.

Check the battery electrolyte level regularly.

Remove the caps on top of the battery and observe the level of the fluid inside. If the zinc plates are exposed, add distilled water until they are covered again. Corroded terminals can impair battery performance and charging ability. Clean them with baking soda and water; then coat them with a preservative or a light film of grease. Be sure all battery connections are tight. When storing the boat, it is best to remove the battery, give it a full charge, and store it inside away from extreme temperatures.

The adapter plug included with your electric trolling motor is designed for battery charging; it fits the receptacle on the forward electrical panel. Your Quantum dealer can recommend a battery charger that is appropriate for whatever capacity battery you choose. Note that this plug is to be attached to a DC battery charger only, and is **NOT** to be used with standard household electric power.

2. *Fuses:*
Power-tilt motors are protected by 20-amp fuses.

Fuse blocks on most models are located behind the instrument panel. Wires are color coded to indicate which accessory each fuse services. Some items, such as radios, may be fused individually at the unit.

Fuel Systems

CAUTION: It is very important that the fuel system be inspected thoroughly the first time it is filled and then at each subsequent filling. For your safety and the safety of your passengers, the fueling instructions in this manual must be followed.

1. *Fuel Fills and Vents:*
Fuel fills are located either on the aft deck or on the side decks adjacent to the aft cockpit. Fuel receptacle caps are marked "Fuel" or "Gas". Fuel vents are normally located in the hull or transom below and in the same general area as the fill. If you experience difficulty filling the fuel tank, check

to see that the fuel fill and vent lines are free of obstructions and kinks.

2. *Fuel Filters:*
All fuel tanks installed by Quantum are equipped with a fine mesh screen filter on the fuel pick-up tube in the tank. In addition, when supplied by the motor manufacturer, an additional filter is installed on the engine. Fuel filters should be checked periodically to see that they are clean and free of debris.

CAUTION: Avoid the storage or handling of gear near the fuel lines, fittings and tank.

Starter Motor

The engine starter motor is designed to deliver high horsepower for only very short periods of time. Avoid operation for more than 15 seconds at a time. Due to its high horsepower, this motor builds up considerable heat and can be permanently damaged with prolonged use. If it does not operate, check the battery charge and all direct wiring for shorts or loose connections.

Bilge Pump

The electric bilge pump supplied with your Quantum is an impeller-type pump. If bilge water is present and the pump motor is running but not pumping, check to see if it is clogged by debris. If it is clear but still does not pump, check the discharge hose for kinks or a collapsed area.

NOTE: The Federal Water Pollution Control Act prohibits the discharge of oil or oil waste into or upon the navigable waters and contiguous zone of the United States if such discharge causes a film or sheen upon, or discoloration of, the surface of the water, or causes a sludge or emulsion beneath the surface of the water. Violators are subject to a penalty of \$5000.

Running Lights

The navigation lights supplied with most Quantum boats are on posts which may be detached when the lights are not in use. When the lightposts are removed and stored (in a safe place), make sure the receptacle cover is snapped closed so that nothing

can become lodged in the receptacle. Although the navigation lights are of top quality, failure may occur for a variety of reasons:

1. There may be a blown fuse. (Replace the fuse in the switch panel.)
2. The bulb may be burned out. (Carry spare bulbs for replacement.)
3. The bulb base may be corroded. (Clean the base periodically and coat it with nonconductive grease.)
4. A wire may have come loose, or may be damaged. (Repair as required.)

NOTE: Prolonged operation of lights (overnight) will result in a dead battery. Be conservative in the use of battery power.

Transom Platforms

1. Platform load must not exceed 250 pounds.
2. Periodically check the platform mounting hardware for looseness and corrosion.

Livewells

On models equipped with livewells, the pump is located aft, adjacent to the bilge pump. Switches for the livewells are located on the forward electrical panel and on the main dash panel. These switches activate aerators that pump a continuous supply of fresh water into the livewell. The overflow is automatically drained overboard. Shutoff valves are located inside both livewells, making it possible to turn off one livewell and run the other one independently. It is advisable to occasionally check the livewells when they are operating to see that the aerators are pumping adequate amounts of water. If there appears to be a problem, check the system for weeds or other debris.

Electric Trolling Motor

Electric motors with remote foot controls are standard on most Quantum boats. The motor is mounted on the bow and is plugged in at the forward electrical panel. When operating, the motor draws power from its own battery. (A voltmeter at the forward electrical panel is provided for this battery.) Be sure to keep the battery properly charged, as the motor's performance will be reduced when run at low

voltages. Charging instructions can be found in the "Electrical Systems" section.

When lowering or raising the motor over the side, use the rope provided in order to avoid injury to yourself and damage to the boat or motor. The area behind the prop should occasionally be checked for weeds, fishing line and other debris. Also, after use in saltwater, rinse the motor with fresh water. During periods of extended nonuse, remove and store the motor. Operating instructions are included in the electric motor owner's manual supplied with your boat.

Ski Tow Posts

Most Quantum boats are equipped with removable ski posts. It is important to make sure that all three pins are secured before using the ski tow post.

Pedestal Seats

Fore and aft pedestal seats should be removed and stowed in a safe and secure area while underway, or when trailering your boat.

GENERAL MAINTENANCE AND REPAIRS

In addition to instructions found elsewhere in this manual and in the literature specific to certain components, the following information is provided for general maintenance and repair.

Because conditions vary widely in different areas, and the frequency and type of use can differ greatly between owners, intervals for maintenance are not listed here. Common sense should determine the frequency of maintenance.

Bilges/Engine

1. Pump the bilges dry and remove all loose dirt. Be sure that all limber holes are open. If there is oil in the bilge and the source is not known, look for leaks in engine oil lines or engine gaskets. Oil stains can be removed by using a bilge cleaner available from your dealer or a marina. Do not use flammable solvents.
2. Inspect the entire fuel system (including fill lines and vents) for any evidence of leakage. Any stains around joints could indicate a leak. Try a

wrench on all fittings to be sure they are not loosening, but do not overtighten them. Clean fuel filters and vent screens.

3. Inspect the entire bottom for evidence of seepage, damage or deterioration, paying particular attention to hull fittings, hoses and clamps. Straighten kinked hoses and replace any that do not feel pliable. Tighten loose hose clamps and replace those that are corroded. Tighten any loose nuts, bolts or screws.
4. Refer to your engine operating manual for engine maintenance details. Wipe off the engine to remove accumulated dust and grease. If a solvent is used, make sure it is nonflammable. Go over the entire engine and tighten nuts, bolts, and screws, including the mounts. Inspect the wiring on the engine and clean and tighten the terminals. Inspect the belts and tighten them if needed. Replace any belt that is cracked or frayed. Clean and lubricate the battery terminals; fill the battery cells with distilled water as needed.

Cabin and Topside Areas

1. Check all wiring to be sure it is properly supported, that its insulation is intact, and that there are no loose or corroded terminals. If there are corroded terminals, they should be replaced or thoroughly cleaned with sandpaper. Tighten all terminals securely and spray them with WD-40 or similar preservative.
2. Check bow rails, ladders and grab rails for loose screws, breaks, sharp edges, etc., that might be hazardous in rough weather. Inventory and inspect life jackets for tears and deterioration. Check your first aid kit to make sure it is complete. Check the signaling equipment. Inspect anchor, mooring and towing lines and repair or replace as required. DO NOT stow wet lines or they may mildew and rot.
3. Salt and brackish water are capable of etching and damaging window glass. Keeping windows clean is the best preventive measure you can take. When window cleaning, flush with plenty of fresh water.

Exercise caution when cleaning windows and doors made of plexiglass because it tends to scratch easily.

First, use generous amounts of water to wash off as much dust as possible. Use your bare hands with plenty of water to dislodge any caked dirt. Then use a soft, grit-free cloth or soft, clean sponge with a detergent or nonabrasive soap. Dry with a clean, damp chamois using a blotting action. Never use a glass cleaning solution or a duster as they will scratch the surface. Remove any grease or oil with kerosene or hexane. DO NOT use solvents such as acetone, benzine, carbon tetrachloride, fire extinguisher fluid, dry cleaning fluid, or lacquer thinner since they will attack the surface.

4. To keep teak looking fresh, it should be treated with teak oil at least twice a year (more often if exposure is severe). If the teak is in particularly bad condition, the teak oil should be rubbed in using 220 grit wet-or-dry sandpaper.
5. Use nearly any of the metal cleaners on the market today to spruce up hardware. After a good cleaning, a coat of paste wax will add

greatly to its luster. All metal fittings and hardware should be sprayed with a rust inhibitor similar to WD-40. If not maintained on a regular basis, stainless steel railings and fittings will discolor.

6. A variety of high quality fabrics have been used in the construction of your boat. Proper care and cleaning of all fabrics will contribute to their long life.

Prior to cleaning any fabric, we suggest that you **test your cleaning solution and method** on a hidden or inconspicuous area.

Convertible tops and vinyl upholstery can be cleaned using a mild soap and water solution. Vinyl cleaners and conditioners are **NOT** recommended for use on Quantum upholstery. To prevent rainwater seepage at the seams, a coating of "Scotch Guard" can be applied on the inside of the vinyl. Mildew can occur if your boat does not have adequate ventilation. Heat alone will not prevent mildew. If mildew does occur, it can be removed using a solution of hot water and laundry bleach (one cup of bleach to one gallon of hot water). Brush the solution into the affected

area, let it sit for 10 to 15 minutes and rinse with plenty of fresh water. If at all possible, the vinyl top parts of your boat should be stored indoors in a fairly warm, dry place. This will greatly extend the life of the material.

Dry cleaning should be considered for interior fabrics other than vinyl.

7. When instruments are exposed to a saltwater environment, salt crystals may form on the bezel and the plastic covers. These salt crystals should be removed with a soft, damp cloth; never use abrasives or rough, dirty cloths to wipe plastic parts. Mild household detergents or plastic cleaners can be used to keep the instruments bright and clean.

Hull

1. The finish on a fiberglass boat is similar to that of an automobile and will respond to the same system of care and cleaning. Car waxes and cleaners are often used to maintain a sparkling finish. Also, a variety of polishes and cleaners for fiberglass are now on the market. We suggest

that you experiment with different brands to determine what you like best.

2. Almost unavoidable during the life of your boat is damage to the gelcoat or colored surface. This is not as serious as you might think. Repair is not costly and can be done by the novice.

Scratches: If the scratch does not penetrate the gelcoat surface, it can be repaired with automotive rubbing compound. Dampen a soft rag and apply the compound by rubbing in a circular motion. The scratch may not disappear completely; however, its noticeability will decrease.

Gouges and Chips: To repair, obtain "patch paste" from your Quantum dealer and follow this recommended procedure:

- Clean the area to be repaired of wax and oil. Acetone is a good solvent.
- Mix a small portion of patch paste and catalyst on a piece of cardboard (two or three drops of catalyst to a tablespoon of paste).
- Apply the paste to the gouge with a putty knife or flat-edged stick; try to match the paste to the surface contour of the area being repaired. It

is better to have an excess of paste, rather than not enough.

- Allow the paste to harden thoroughly. In most climates, one to two hours should be sufficient.
- Shape the patch as desired, using fine wet sandpaper.
- Finish by using automotive rubbing compound in the same manner as you did for scratches.

WARNING! Teak oil, acetone and catalyst are hazardous materials and should be used only in well ventilated areas. Follow the manufacturer's instructions.

3. Special Care for Boats That Are Moored
If permanently moored in salt water or fresh water, your boat will collect marine growth on its bottom. This will detract from the boat's beauty and greatly affect its performance. There are two methods of preventing this:
 - Periodically haul the boat out of the water and scrub the bottom with a bristle brush and a solution of soap and water.
 - Paint the hull below the waterline with a good grade of antifouling paint.

IMPORTANT: Quantum recommends the application of an epoxy barrier coating, such as International Paint Company's Interlux "Interprotect 2000 System", to help seal the hull bottom and reduce the possibility of gelcoat blistering. The barrier coating should be covered with several coats of antifouling paint. Note that many states regulate the chemical content of bottom paints in order to meet environmental standards. Check with your local Quantum dealer about recommended bottom paints, and about laws that are in effect in your area.

4. Whenever your boat is out of the water you should check all metal parts for stray current corrosion. Stray current corrosion, or electrolysis, can be prevented several ways. The following are the most common causes and the simplest cures:
 - Wiring may leak a certain amount of electricity. Keep a clean, dry bilge.
 - A poorly grounded zinc anode: Check the ground wire and clean all contact surfaces.
 - The zinc anode may be deteriorated beyond effectiveness. Replace it when it has deteriorated 50% or more.

- Do not use a copper-based bottom paint, as it can cause electrolysis on some metal parts. If your boat is permanently moored, we recommend that you contact someone in your area specializing in corrosion control and have them check your boat in its moorage to see that it is properly protected.

5. Propellers should be inspected often for damage. Every attempt has been made to equip your boat with a propeller that will optimize performance. However, your boating needs may dictate a propeller change. Your Quantum dealer can help you in the selection of propellers better suited to your needs.

On those high performance Quantum models capable of speeds in excess of 50 mph, "cavitation burn" may be experienced on the propeller. Propellers on these boats should be checked frequently for cavitation burn if the boat is continuously operated at high speeds. Replace propellers as necessary when severe burn occurs. High performance propellers constructed of bronze or stainless steel are available from the propeller manufacturers, but using these could void the warranty of your drive unit.

STORAGE

The following suggestions are offered for storage at the end of your boating season.

1. Your boat should be stored under cover if possible. If covered storage isn't available, a temporary winter cover is recommended. A proper winter cover should keep weather off the boat, but still provide adequate ventilation. Wrapping a boat up in a tight plastic cover can do more damage than good. Dampness and lack of air circulation provide ideal conditions for fungi that cause mildew and dry rot.
2. If you are storing your boat on its trailer:
 - Now is a good time to repack the trailer's wheel bearings. Your local auto service center can help you.
 - Block the trailer wheels off the ground to avoid tire deterioration.
 - Loosen the stern tie-downs to avoid stress on the hull.
3. Refer to your engine manual for engine storage instructions.
4. Remove the marine battery from the boat. Fill the cells to the proper level and store your battery in a warm place. A fully charged battery will survive storage better.
5. Fuel tanks should be filled so there is little air space, thereby minimizing condensation.
6. Thoroughly clean your boat. If possible, remove cushions, mattresses, towels, and other items that can hold moisture and cause mildew. Such items left on board should be positioned for maximum air circulation. It helps to stand mattresses and cushions on edge.
7. Clean all deck hardware; then coat the hardware with rust inhibitor.
8. Lubricate the steering mechanism and throttle control linkage.

We hope these preventive measures will help make getting ready again in the spring easier. Should you have any questions, your Quantum dealer is eager to provide assistance.

NAUTICAL TERMS

ABEAM:	On either side of the boat.	KEEL:	The lowest external portion of the boat.
AFT:	To the rear, or near the stern.	KNOT:	Nautical mile per hour; one nautical mile is 6,076 ft.; a land mile is 5,280 ft.
BEAM:	The width of the hull.	LEE:	Opposite side from which the wind blows.
BILGE:	The lowest portion inside a boat (in a fiberglass boat, generally the underdeck and lower portion of the engine compartment).	MAYDAY:	International spoken distress signal for radiotelephone communications.
BOW:	The forward portion of the boat.	PORT:	To the left side of the boat.
CHINE:	The intersection of the side and bottom of a V-bottom boat.	PORTLIGHT:	A hinged window in the boat's cabin or hull.
DRAFT:	Vertical distance from the waterline of the boat to the lowest point of the boat.	SCUPPER:	An opening in a deck or cockpit permitting water to drain overboard.
FATHOM:	A measurement of six feet generally used to measure water depth.	STANCHION:	A fixed, upright post used for support (of rails or lifelines).
FREEBOARD:	Vertical distance from the deck to the waterline.	STARBOARD:	To the right side of the boat.
GUNWALE:	The point where the hull and deck meet.	STERN:	The rear of the boat.
HATCH:	A covered opening in the deck.	STERN DRIVE:	Inboard/outboard propulsion unit.
HEAD:	Toilet or toilet room.	TRANSOM:	The vertical part of the stern.
HELM:	Steering wheel.	WINDWARD:	The direction from which the wind is blowing.





SCHEMATIC WIRING DIAGRAM

Quantum 1604

COLOR CODE

B - BLACK
 BL - BLUE
 BR - BROWN
 G - GREEN
 GY - GRAY
 O - ORANGE
 P - PINK
 PU - PURPLE
 R - RED
 T - TAN
 W - WHITE
 Y - YELLOW
 LT - LIGHT
 DK - DARK

SYMBOLS

SWITCH 
 FUSE (1) 
 CONNECTION 
 NO CONNECTION 
 GROUND 

NOTES

(1) 10 AMP UNLESS OTHERWISE NOTED.

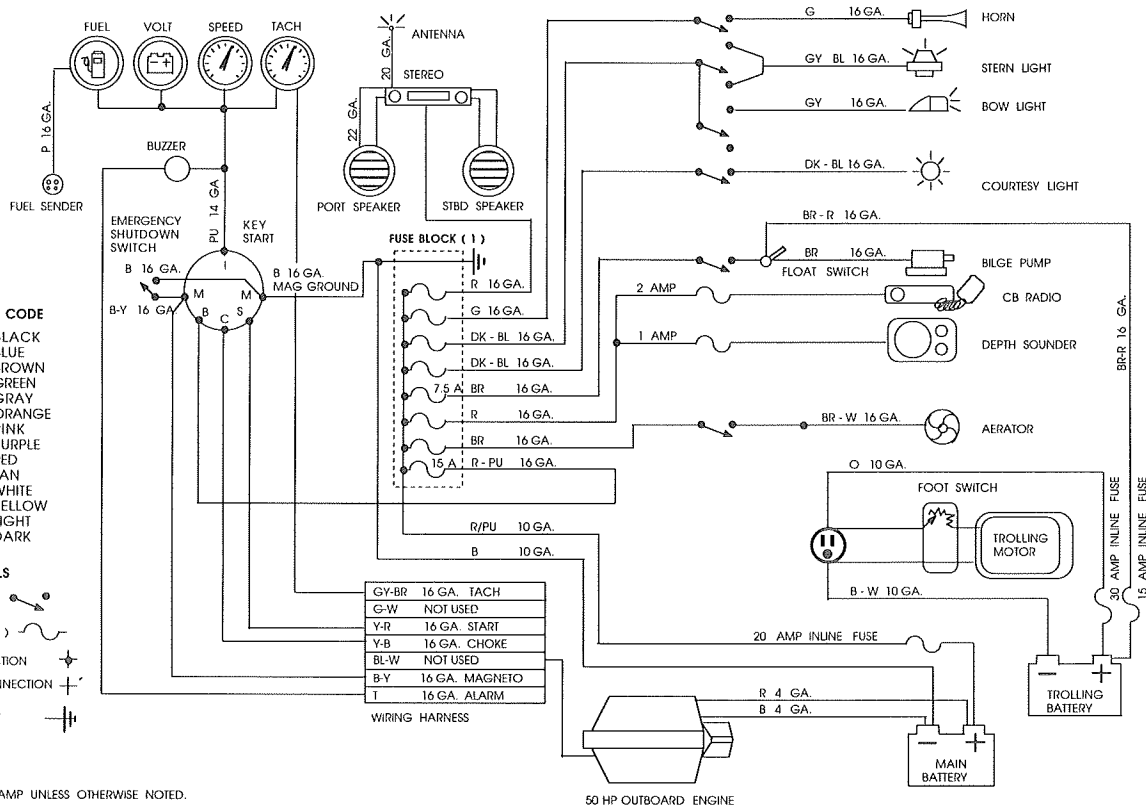

SCHEMATIC WIRING DIAGRAM

Quantum 1704 and 1804

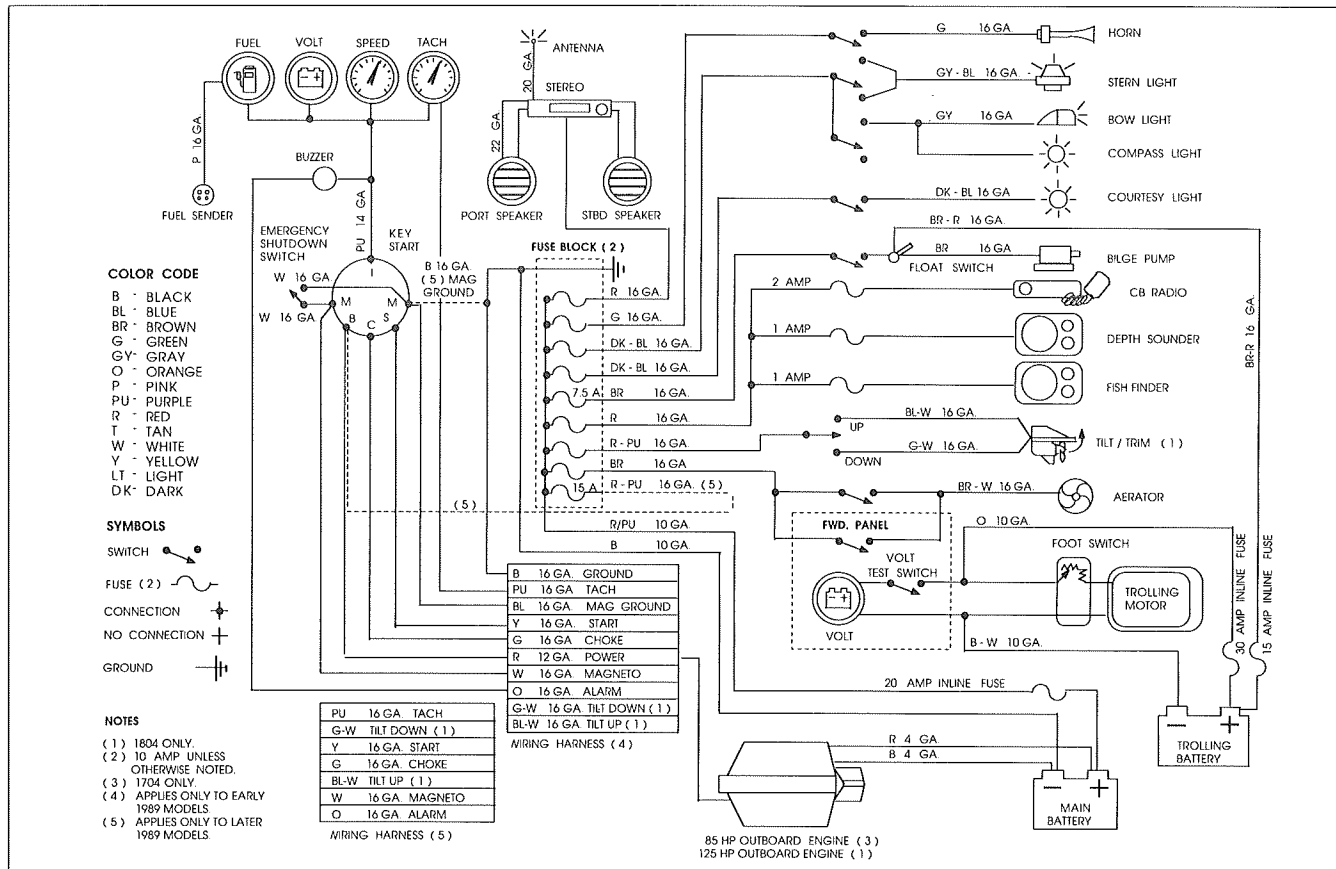





SCHEMATIC WIRING DIAGRAM

Quantum 2004

COLOR CODE

B · BLACK
 BL · BLUE
 BR · BROWN
 G · GREEN
 GY · GRAY
 O · ORANGE
 P · PINK
 PU · PURPLE
 R · RED
 T · TAN
 W · WHITE
 Y · YELLOW
 LT · LIGHT
 DK · DARK

SYMBOLS

SWITCH 
 FUSE (1) 
 CONNECTION 
 NO CONNECTION 
 GROUND 

NOTES

(1) 10 AMP UNLESS OTHERWISE NOTED

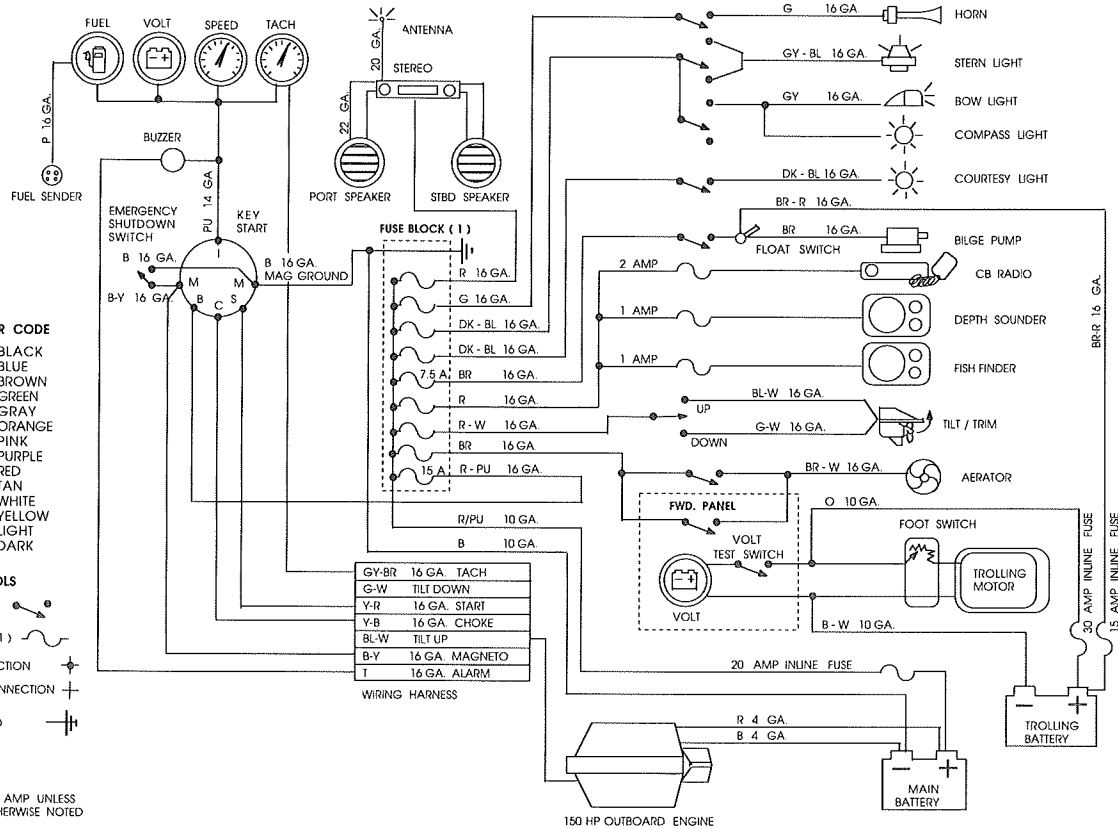

WARRANTY

One Year Limited Warranty

Quantum warrants to the original purchasers of its boats operated under normal, noncommercial use in the U.S. or Canada that it will repair or replace any parts found to be defective in factory materials or workmanship within one year from the date of retail delivery.

What Is Not Covered

This warranty does not apply to: (1) Engines, controls, props, batteries or other equipment or accessories carrying their own individual warranties; (2) Engines, parts or accessories not installed by Quantum ; (3) Window breakage or leaks; gelcoat finish, blisters, cracks or crazing; (4) Hardware, vinyl tops, vinyl and fabric upholstery, plastic, metal, wood or tape trim; (5) Any Quantum boat which has been altered, subjected to misuse, negligence or accident, or used for racing purposes; (6) Any Quantum boat which has been overpowered according to the maximum horsepower specifications on the capacity plate provided on each Quantum outboard boat; (7) Any Quantum boat used for commercial purposes; (8) Any defect caused by failure of the customer to provide reasonable care and maintenance.

Other Limitations

THERE IS NO OTHER EXPRESS WARRANTY ON THIS BOAT. TO THE EXTENT ALLOWED BY LAW:

1. Any implied warranty of merchantability is limited

to the duration of this written warranty.

2. Neither Quantum nor the selling dealer shall have any responsibility for loss of use of the boat, loss of time, inconvenience, commercial loss or consequential damages.
3. Some states do not allow limitations on how long any implied warranty lasts, so the above limitation may not apply to you. Some states do not allow the exclusion or limitation of incidental or consequential damages, so the above limitation or exclusion may not apply to you. This warranty gives you specific legal rights, and you may also have other rights which vary from state to state.

Your Obligation

In order to comply with Federal regulations, it is essential that your warranty registration card be submitted within 30 days of delivery of your boat. Return of this card is a condition precedent to warranty coverage. Before any warranty work is performed, we require that you contact your selling dealer to request warranty assistance.

We require that you return your boat, at your expense, to your selling dealer or, if necessary, to the Quantum factory. You will be responsible for all transportation, haulouts and other expenses incurred in returning the boat for warranty service.

Quantum Marine
PO Box 9019
Everett, WA 98206
Phone (206) 435-6534

**QUANTUM
MARINE**

PO Box 9019
Everett, WA 98206

(206) 435-6534

An Affiliate of US Marine,
A Brunswick Company