

BAYLINER[®]

315 Cruiser

Owner's Manual *Supplement*

Port Engine Serial Number: _____

Starboard Engine Serial Number: _____

Hull Identification Number: _____

Hull Identification Number

- The Hull Identification Number (HIN) is located just below the deck gunnel at the starboard aft corner of the boat.
- Record the HIN (and the engine serial numbers) in the space provided above.
- Include the HIN with any correspondence or orders.

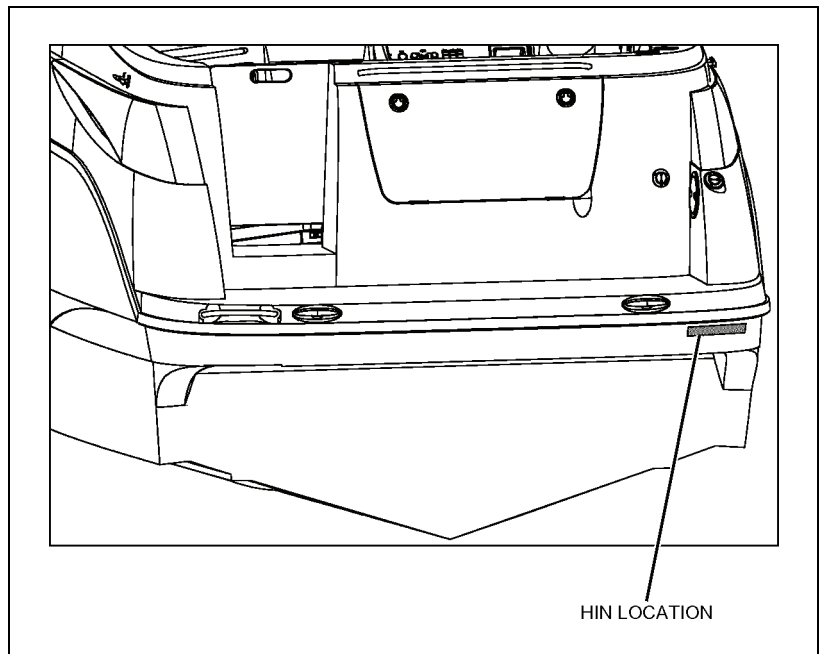

© 2010 Bayliner Technical Publications. All rights reserved.

No part of this publication may be reproduced, stored in any retrieval system, or transmitted in any form by any means, electronic, mechanical, photocopying, recording or otherwise, without prior written permission of Bayliner.

Printed in the United States of America.

General Notes

The material in this document is for information only and is subject to change without notice. While reasonable efforts have been made in the preparation of this document to assure its accuracy, Bayliner assumes no liability resulting from errors or omissions in this document, or from the use of information contained herein. Due to our commitment to product improvement, Bayliner reserves the right to make changes in the product design, specifications, and equipment at any time without notice or obligation. Illustrations and/or photos may show optional equipment.

All Bayliner products meet or exceed USCG (United States Coast Guard) and/or NMMA (National Marine Manufacturer's Association) construction standards. Manufactured with 1,1,1 Trichloroethane, a substance which harms public health and environment during the manufacturing process by destroying ozone in the upper atmosphere.

Proprietary Rights

This document discloses subject matter in which Bayliner has proprietary rights. The information and design disclosed herein were originated by and are the property of Bayliner. Neither receipt nor possession thereof confers or transfers any right to reproduce, copy, alter or disclose the document or any part thereof, any information contained therein, or to construct boats or any item from it, except by written permission from or written agreement with Bayliner. This document is to be returned upon request to Bayliner.

CONTENTS

Chapter 1: Welcome Aboard!

- Dimensions & Tank Capacities 1
- Dealer Service 1
- Warranty Information 1
- Boating Experience 2
- Qualified Maintenance 2
- Engine & Accessory Guidelines & Literature 3
 - Propellers 3*
- Special Care for Moored Boats 4
 - Sacrificial Anode (Zinc) 4*
- Boat Lifting 5
- Safety Standards 6
 - Deck Safety 7*
- Carbon Monoxide (CO) 7
 - CO Facts 7*
 - Factors that Increase the Effects of CO Poisoning 7*
 - Where & How CO Can Accumulate 8*
 - How to Protect Yourself & Others From CO 8*
 - CO Checklists 9*
 - CO Monitors 9*
 - More Information 10*
- Warnings & Warning Labels 11
 - Warning Labels 11*
 - Sliding Entry Door Warning 13*

Chapter 2: Locations

- Exterior Views 14
 - Hull Views 14*
 - Deck Views 15*
 - Helm 16*
- Component Locations 17

Chapter 3: Propulsion & Related Systems

- Engines 33
- Bilge Blower System 33
- Engine Cooling Systems (If Equipped) 34
 - Gas Engine Cooling System 34*
 - Diesel Engine Cooling System 34*
- Fuel System 35
 - Fuel Fill & Vent 36*
 - Anti-siphon Valves (Gas Engines Only) 36*
 - Gas Engine Fuel Filters 37*
 - Diesel Engine Fuel Filter/Water Separators 37*
 - Electronic Fuel Shut-off Valves (Diesel Engines Only) 38*
- Engine Hatch Lift System (If Equipped) 38
- Fire Suppression System (If Equipped) 39

Chapter 4: Controls & Gauges

- Steering 40
- Shift/Throttle Controls 40
- Power Trim & Tilt 40
- Trim Tabs 40
- Gauges 41
 - Cleaning the Gauges 41*
 - Gauge Fogging 41*
 - Radio Transmission Interference 41*
 - Fuel Gauge 41*
 - Twin Engine Readings 41*

Chapter 5: Navigation & Communication Equipment

- Compass 42
- Depth Finder (If Equipped) 42
- VHF Radio (If Equipped) 43
- Global Positioning System (GPS) (If Equipped) 43

Chapter 6: Plumbing

Bilge Pumps 44

Bilge Pump Testing 45

Built-in Autofloat Switch Testing 45

Seawater Systems 46

Seacocks 46

Seawater Strainers 46

Freshwater System 47

Transom Shower (If Equipped) 48

Freshwater System Winterization 48

Water Heater 49

Winterizing the Water Heater 50

*Preparing the Water Heater
for Use After Boat Storage 51*

Drain Systems 52

Deck Drains 52

Galley Sink Drain 52

Sump Pump System 52

Marine Head & Holding Tank 53

Manual Flush Head (If Equipped) 53

Electric Flush Head (If Equipped) 54

Macerator (If Equipped) 55

Air Conditioner (If Equipped) 56

Chapter 7: Deck Equipment

Cleats & Bow/Stern Eyes 57

Windlass (If Equipped) 57

Canvas 58

Canvas & Vinyl Tops & Enclosures 58

Bimini Top (If Equipped) 58

Aft Bimini Top 59

Vinyl Curtains (If Equipped) 59

Canvas Care 60

Clear Vinyl Care 61

Chapter 8: Appliances & Entertainment Systems

Alcohol/110-Volt Electric Stove 62

Refrigerator 63

Audio 63

Chapter 9: Convertible Seats, Beds, & Tables

Dinette to Sleeping Berth Conversion 64

Cockpit Sunlounge Conversion 66

Helm Seat 68

To Slide Helm Seat: 68

To Swivel Helm Seat (If Equipped): 68

Chapter 10: Lights

Care & Maintenance 69

Interior & Exterior Lights 69

Navigation Lights 69

Spotlight (If Equipped) 69

Chapter 11: Electrical System

12-Volt DC System 71

Batteries 71

Battery Switches 71

Fuses & Circuit Breakers 71

12-Volt DC Accessory Outlets 72

Alternators 72

Battery Charger (If Equipped) 72

110-Volt AC System 73

Shore Power 74

Connecting to Shore Power 75

*Parallel Switch (Only if
Equipped with Dual Shore Power) 75*

Generator (If Equipped) 76

Electrical Routings 78

12-Volt DC Hull Harness 78

12-Volt DC Deck Harnesses 79

12-Volt DC Radar Arch Harness 80

Battery Cable Routings 81

110-Volt AC Hull Harnesses 82

Important Records 83

Float Plan 84

Hazard Boxes & Symbols

The hazard boxes and symbols shown below are used throughout this supplement to call attention to potentially dangerous situations which could lead to either personal injury or product damage. Read *all* warnings carefully and follow *all* safety instructions.

 **DANGER!**
This box alerts you to immediate hazards which *WILL* cause severe personal injury or death if the warning is ignored.

 **WARNING!**
This box alerts you to hazards or unsafe practices which *COULD* result in severe personal injury or death if the warning is ignored.

 **CAUTION**
This box alerts you to hazards or unsafe practices which *COULD* result in minor personal injury or cause product or property damage if the warning is ignored.

NOTICE
This box calls attention to installation, operation or maintenance information, which is important to proper operation but is not hazard related.

 FIRE HAZARD!	 EXPLOSION HAZARD!	 NO OPEN FLAME!	 ELECTRICAL HAZARD!	 HOT HAZARD!
---	--	---	--	--

 FALLING HAZARD!	 ROTATING PROPELLER HAZARD!	 RUN BILGE BLOWERS FOR 4 MINUTES!
--	---	--

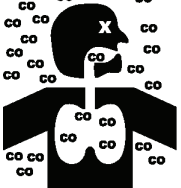
CO POISONING HAZARD!

Chapter 1: Welcome Aboard!

- This *Owner's Manual Supplement* provides specific information about your boat that is **not** covered in the *Cruiser & Yacht Owner's Manual*.
- The *Cruiser & Yacht Owner's Manual* contains general information about safe operating practices, general boating regulations, and general maintenance techniques. Information that is more specific to your particular boat is found in this *Owner's Manual Supplement*.
- **Before** using your boat, study this *Owner's Manual Supplement*, the *Cruiser & Yacht Owner's Manual*, and **all** engine and accessory literature carefully. If similar instructions are found in more than one manual, **always** refer to the specific manufacturer's manual (such as the engine manual) for the most complete and accurate information.
- Keep this *Owner's Manual Supplement* and the *Cruiser & Yacht Owner's Manual* on your boat in a secure, yet readily available place.

Dimensions & Tank Capacities

Overall Length	Length Rigid	Bridge Clearance	Beam	Draft (Hull)	Draft (Maximum)	Fuel Capacity	Freshwater Capacity	Holding Tank Capacity
30' 6"	31' 8"	9' 6"	10' 0"	2' 1"	3' 4"	120 Gallons	30 Gallons	30 Gallons

Dealer Service

- Your dealer is your key to service.
- Ask your dealer to explain **all** systems **before** taking delivery of your boat.
- Contact your dealer if you have any problems with your new boat.
- If your dealer cannot help, call our customer service hotline: 360-435-8957 or send us a FAX: 360-403-4235.
- Buy replacement parts from any authorized Bayliner dealer.
- You can access on-line parts catalogs, links to vendor websites, and other helpful features by logging on to <http://www.baylinerparts.com>.

Warranty Information

- Bayliner offers a Limited Warranty on each new Bayliner purchased through an authorized Bayliner dealer.
- A copy of the Limited Warranty was included in your owner's packet.
- If you did not get a copy of the Limited Warranty, please contact your Bayliner dealer or call 360-435-8957 for a copy.

Boating Experience

 WARNING!
<p>CONTROL HAZARD!</p> <p>An experienced operator MUST be in control of your boat at ALL times. Do NOT operate your boat while under the influence of alcohol or drugs.</p>

If this is your first boat or if you are changing to a type of boat you are *not* familiar with, for your own comfort and safety, get handling and operating experience *before* assuming command of your boat.

Take one of the boating safety classes offered by the U.S. Power Squadrons or the U.S. Coast Guard Auxiliary. For more course information, including dates and locations of upcoming classes, contact the organizations directly:

- U.S. Power Squadrons: 1-888-FOR-USPS (1-888-367-8777) or on the Internet at: <http://www.usps.org>
- In Canada, for the CPS courses call 1-888-CPS-BOAT.
- U.S. Coast Guard Auxiliary: 1-800-368-5647 or on the Internet at: <http://www.cgaux.org>

Outside the United States, your selling dealer, national sailing federation, or local boat club can advise you of local sea schools or competent instructors.

Qualified Maintenance

 WARNING!
<p>To maintain the safety of your boat, allow ONLY trained personnel to work on, or change, in any way, the:</p> <ul style="list-style-type: none"> • Steering system • Propulsion system • Engine control system • Fuel system • Environmental control system • Electrical system • Navigation system

- Failure to maintain your boat's systems (listed in the warning above) as designed could violate the laws in your jurisdiction and could expose you and other people to the danger of bodily injury or accidental death.
- Follow the instructions provided in the *Cruiser & Yacht Owner's Manual*, this *supplement*, the engine owner's manual, and **all** accessory literature.

Engine & Accessory Guidelines & Literature

NOTICE

BEFORE starting or working on your engine(s), read the engine manual.

NOTICE

BEFORE using the accessories on your boat, read the accessory manuals.

NOTICE

BEFORE storing your boat, refer to your engine and accessory manuals for storage/winterization instructions.

NOTICE

Certain modifications to your boat WILL result in cancellation of your warranty protection. ALWAYS check with your dealer BEFORE making any modifications to your boat.

- Your boat's engines and accessories were selected to provide optimum performance and service.
- Installing a different engines or adding accessories may affect your boat's running trim.
- If you choose to install a different engines or add accessories that may affect your boat's running trim, have a trained marine technician perform a safety inspection and handling test **before** using your boat again.
- The engines and accessories on your boat have their own manuals. Read these manuals **before** using the engines and accessories.

Unless noted otherwise, **all** engine and accessory literature referred to in this *Owner's Manual Supplement* is included in your owner's packet.

While the topics listed below may be included in this *Owner's Manual Supplement* and in the *Cruiser & Yacht Owner's Manual*, **always** refer to the engine manual first for specific information on these important subjects:

- Engine Break-in Procedure
- Engine Starting and Stopping
- Gear Shifting
- Fuel and Oil Recommendations
- Engine Maintenance
- Engine Storage/Winterization

Propellers



CAUTION

ENGINE DAMAGE HAZARD!

The factory standard propellers may not be the best for your particular boat and load conditions. Refer to the engine manual for engine RPM ratings. The engines should reach, but not exceed the full rated RPM when full-throttle is applied.

Immediately contact your local Bayliner dealer if:

- The engines cannot reach the full rated RPM when full-throttle is applied, or;
- The engines exceed the full rated RPM when full-throttle is applied.

- Keep the propellers in good repair and at the correct pitch for your particular situation.
- A slightly bent or nicked propeller will adversely affect the performance of your boat.

Special Care for Moored Boats

NOTICE

Boats Without Bottom Paint:

- To help seal the hull bottom and reduce the chance of gel coat blistering while your boat is moored, apply an epoxy barrier coating.
- The barrier coating should be covered with several coats of anti-fouling paint.
- Many states regulate the chemical content of bottom paints in order to meet environmental standards. Check with your local dealer about recommended bottom paints, and about the laws in effect in your area.

- Whether moored in saltwater or freshwater, your boat will collect marine growth on its hull bottom.
- This will detract from your boat's beauty, greatly affect its performance, and may damage the gel coat.

There are two ways to slow marine growth:

1. Periodically haul your boat out of the water and scrub the hull bottom with a bristle brush and a solution of soap and water.
2. Occasionally reapply the anti-fouling paint on your hull bottom. How often your hull needs new anti-fouling paint depends on many factors. Ask your selling dealer or local marina for advice.

Sacrificial Anode (Zinc)

NOTICE

- Do **NOT** paint between the zinc and the metal surface it contacts and do **NOT** paint over the zinc.
- If the zinc is **NOT** bonded correctly, it will **NOT** provide protection.

Your boat is equipped with a sacrificial anode (zinc) to protect underwater metal parts from excessive deterioration. Check the zinc regularly and replace it if it has deteriorated more than 70%.

Many factors affect the rate at which the zinc deteriorates, including:

- Water temperature
- Salinity
- Water pollution
- Stray electrical current

Stray electrical current from your boat, another boat, or the dock may cause complete deterioration of the zinc in just a few weeks. If there is rapid zinc deterioration, measure the electrolytic corrosion around your boat with a corrosion test meter.



NEW SACRIFICIAL ANODE

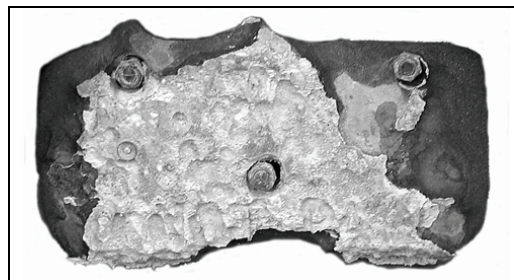

DETERIORATED SACRIFICIAL ANODE

Boat Lifting



WARNING!

PERSONAL INJURY and/or PRODUCT or PROPERTY DAMAGE HAZARD!

- Lifting slings can slip on the hull, which could cause serious injury or death.
- Reduce the risk of sling slippage by **ALWAYS** securing the lifting slings together **BEFORE** lifting.



WARNING!

PERSONAL INJURY and/or PRODUCT or PROPERTY DAMAGE HAZARD!

NEVER lift any boat using the cleats, or the bow/stern eyes.



WARNING!

PERSONAL INJURY and/or PRODUCT or PROPERTY DAMAGE HAZARD!

- Water in the bilge can shift and change the balance of the load.
- If water is present in the bilge, pump or drain the water out of the bilge areas **BEFORE** lifting your boat.



CAUTION

PRODUCT or PROPERTY DAMAGE HAZARD!

- When lifting any boat, **ALWAYS** use a spreader bar.
- The spreader bar **MUST** be equal to the width of the boat at each lifting point.
- Make sure your boat remains level during lifting. Engines can be damaged by water ingestion if the stern is lifted higher than the bow.

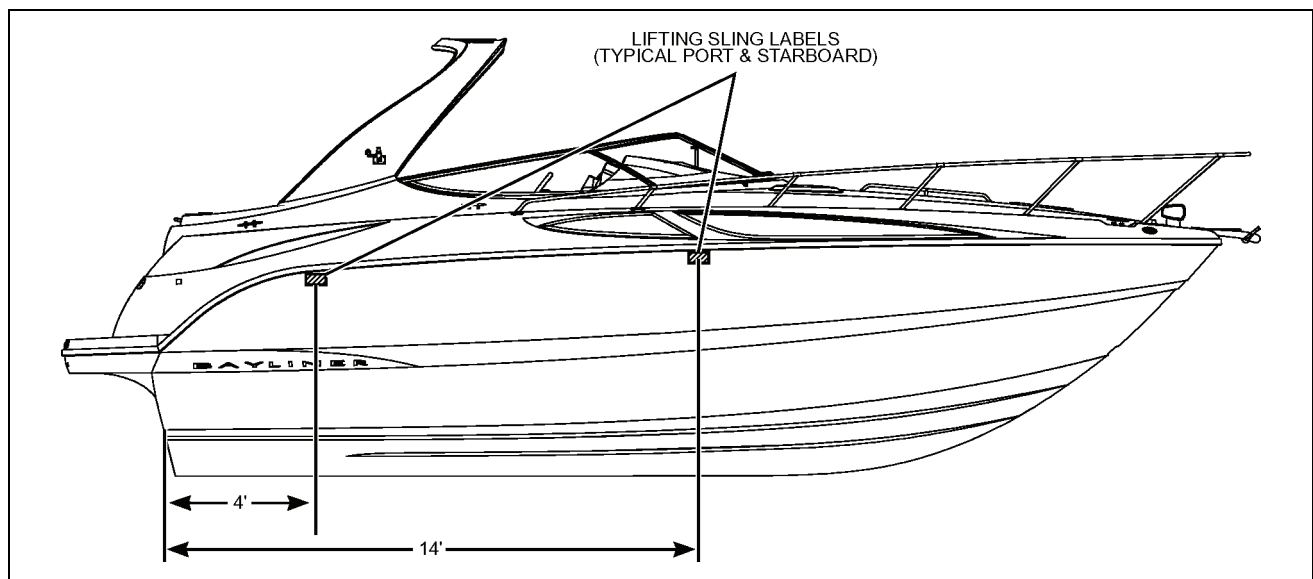

- **Always** follow the lift equipment's instructions and requirements.
- When lifting your boat, **always** position the lifting slings at the port and starboard lifting sling label positions as shown in the illustration.

Safety Standards



⚠ DANGER!



FALLING and ROTATING PROPELLER HAZARD!

- ***NEVER*** allow anyone to ride on parts of your boat ***NOT*** designed for such use.
- Sitting on seat-backs, lounging on the forward deck, bow riding, gun-wale riding or occupying the transom platform while underway is especially hazardous and ***WILL*** cause personal injury or death.

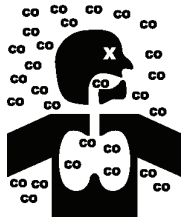
⚠ DANGER!

FALLING, ROTATING PROPELLER and CARBON MONOXIDE POISONING HAZARD!

- ***NEVER*** allow anyone to occupy, or hang from, the back deck or transom platform while the engines are running.
- Teak surfing, dragging, or water skiing within 20 feet of a moving watercraft can be fatal.

⚠ DANGER!

PERSONAL SAFETY HAZARD!

- ***ALWAYS*** secure the anchor and other loose objects ***BEFORE*** getting underway.
- The anchor and other items that are ***NOT*** properly secured can come loose when your boat is moving and cause personal injury or death.

⚠ WARNING!

A wide variety of components used on this vessel contain or emit chemicals known to the State of California to cause cancer and birth defects and other reproductive harm.

Examples Include:

- Engine and generator exhaust
- Engine and generator fuel, and other liquids such as coolants and oil, especially used motor oil
- Cooking fuels
- Cleaners, paints, and substances used for vessel repair
- Waste materials that result from wear of vessel components
- Lead from battery terminals and from other sources such as ballast or fishing sinkers

To Avoid Harm:

- Keep away from engine, generator, and cooking fuel exhaust fumes.
- Wash exposed skin thoroughly with soap and water after handling the substances above.

- Your boat's mechanical and electrical systems were designed to meet safety standards in effect at the time it was built.
- Some of these standards were mandated by law, and all of them were designed to insure your safety and the safety of other people, vessels and property.

Read this *supplement*, the *Cruiser & Yacht Owner's Manual*, and ***all*** accessory instructions for important safety standards and hazard information.

Deck Safety

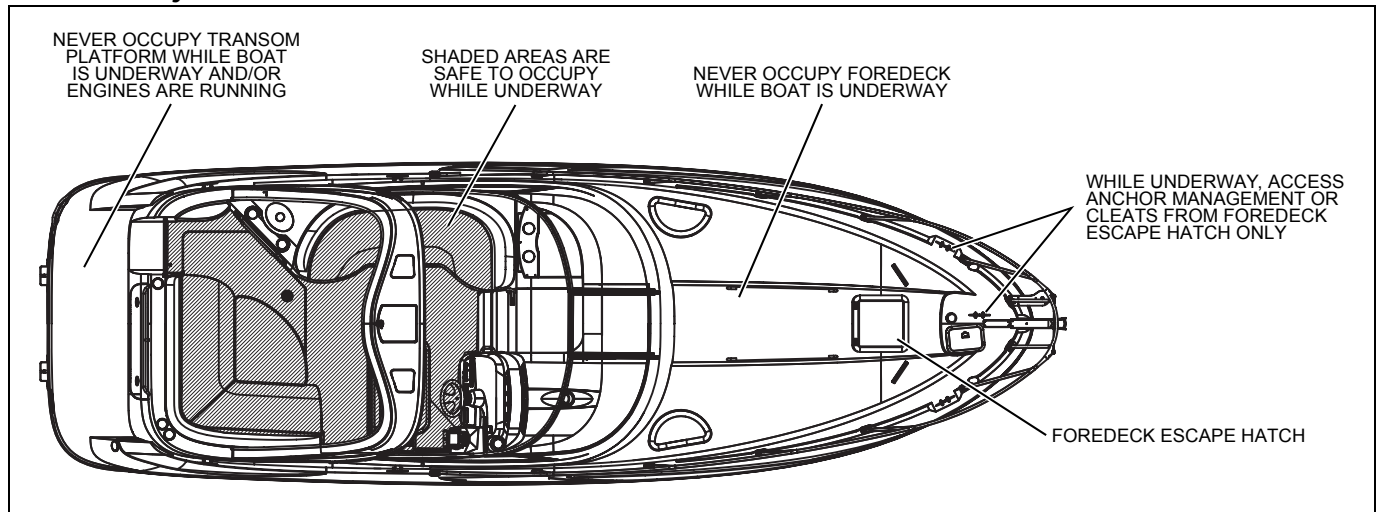

Carbon Monoxide (CO)

⚠ **DANGER!**

- Carbon monoxide gas (CO) is colorless, odorless, tasteless, and extremely dangerous.
- *ALL* engines, generators, and fuel burning appliances produce CO as exhaust.
- Prolonged exposure to low concentrations or very quick exposure to high concentrations *WILL* cause *BRAIN DAMAGE* or *DEATH*.
- Teak surfing, dragging, or water skiing within 20 feet of a moving watercraft can be fatal.

CO Facts

- CO poisoning causes a significant number of boating deaths each year.
- Called the "silent killer", CO is an extremely toxic, colorless, odorless and tasteless gas.
- CO can harm or even kill you inside or outside your boat.
- CO can affect you whether you're underway, moored, or anchored.
- CO symptoms are similar to seasickness or alcohol intoxication.
- CO can make you sick in seconds. In high enough concentrations, even a few breaths can be fatal.
- Breathing CO blocks the ability of your blood to carry oxygen.
- The effects are cumulative. Even low levels of exposure can result in injury or death.

Factors that Increase the Effects of CO Poisoning

- Age
- Smokers or people exposed to high concentrations of cigarette smoke
- Consumption of alcohol
- Lung disorders
- Heart problems
- Pregnancy

Where & How CO Can Accumulate

Stationary conditions that increase CO accumulations include:

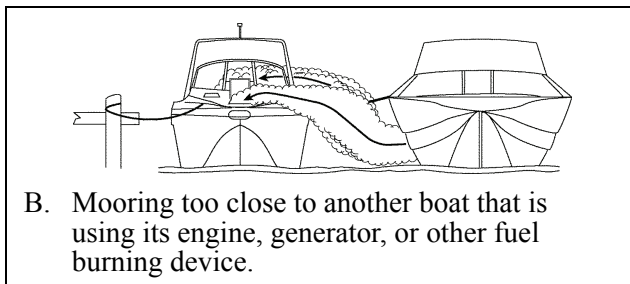
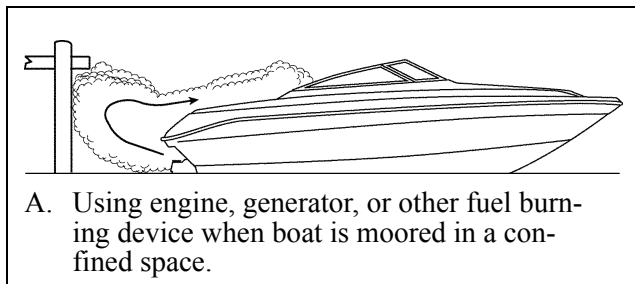

To correct stationary situations A and/or B:

- **Close all** windows, portlights and hatches.
- If possible, move your boat away from source of CO.

Running conditions that increase CO accumulations include:

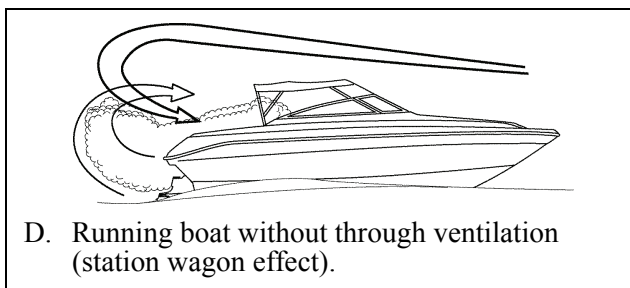
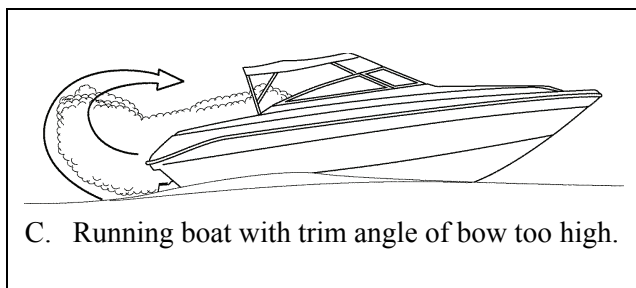

To correct running situations C and/or D:

- Trim bow down.
- **Open** windows and canvas.
- When possible, run boat so that prevailing winds help dissipate exhaust.

How to Protect Yourself & Others From CO

- Know where and how CO may accumulate in and around your boat (see above).
- **Always** maintain fresh air circulation throughout your boat.
- Know where your engine and generator exhaust outlets are located and keep everyone away from these areas.
- **Never** sit on, or hang onto, the back deck or swim platform while the engines are running.
- **Never** enter the areas under swim platforms where exhaust outlets are located.
- Although CO can be present without the smell of exhaust fumes, if exhaust fumes are detected on your boat, take **immediate** action to dissipate these fumes.
- Treat symptoms of seasickness as possible CO poisoning. Get the person into fresh air **immediately**. Seek medical attention—unless you're sure it's **not** CO.
- **Maintain the CO monitors that are installed inside your boat.** **Never** ignore any alarm. Replace monitors as recommended by the monitor manufacturer.
- Follow the checklists provided on the next page.
- Get a Vessel Safety Check.

For information on how to get a free VESSEL SAFETY CHECK, visit www.vesselsafetycheck.org or contact your local U.S. Coast Guard Auxiliary or United States Power Squadrons®.

- U.S. Coast Guard Auxiliary: 1-800-368-5647 or on the Internet at: <http://www.cgaux.org>
- U.S. Power Squadrons: 1-888-FOR-USPS (1-888-367-8777) or on the Internet at: <http://www.usps.org>

CO Checklists

Trip Checklist

- Make sure you know where the exhaust outlets are located on your boat.
- Educate *all* passengers about the symptoms of CO poisoning and where CO may accumulate.
- When docked, or rafted with another boat, be aware of exhaust emissions from the other boat.
- Listen for any change in exhaust sound, which could mean an exhaust component failure.
- Test the operation of each CO monitor by pressing the test button.

Monthly Checklist

- Make sure *all* exhaust clamps are in place and secure.
- Look for exhaust leaking from exhaust system components. Signs include rust and/or black streaking, water leaks, or corroded or cracked fittings.
- Inspect rubber exhaust hoses for burned, cracked, or deteriorated sections. *All* rubber hoses should be pliable and free of kinks.

Annual Checklist

Have a Trained Marine Technician:

- Replace exhaust hoses if cracking, charring, or deterioration is found.
- Ensure that your engines and generators are properly tuned, and well maintained.
- Inspect each water pump impeller and the water pump housing. Replace if worn. Make sure cooling systems are in working condition.
- Inspect *all* metallic exhaust components for cracking, rusting, leaking, or loosening. Make sure they check the cylinder head gasket, exhaust manifold, water injection elbow, and the threaded adapter nipple between the manifold and the elbow.
- Clean, inspect, and confirm proper operation of the generator cooling water anti-siphon valve (if equipped).

CO Monitors

NOTICE

- The stereo memory and CO monitors place a small, but constant drain on the battery.
- If your boat will be unattended for an extended amount of time, plug into shore power with the battery charger turned *On*.

- Do *not* disconnect the CO monitors.
- Read the manufacturer's instructions for your CO monitors. **If you did not get the manufacturer's instructions, call (800) 383-0269 and they will be mailed to you.**

If your boat is *not* equipped with a CO monitor, consider purchasing one from your dealer or marine supply store.

More Information

For more information about preventing carbon monoxide poisoning on recreational boats and other boating safety tips, contact:

United States Coast Guard Office of Boating Safety (G-OPB-3) 2100 Second Street SW Washington, DC 20593 www.uscgboating.org 1-800-368-5647	National Marine Manufacturers Association (NMMA) 200 East Randolph Drive Suite 5100 Chicago, IL 60601-9301 www.nmma.org 312-946-6200	American Boat & Yacht Council, Inc. (ABYC) 613 Third Street Suite 10 Annapolis, MD 21403 www.abycinc.org 410-990-4460
---	--	---

For information about free VESSEL SAFETY CHECKS, visit www.vesselsafetycheck.org or contact your local U.S. Coast Guard Auxiliary or United States Power Squadrons®.

- U.S. Coast Guard Auxiliary: 1-800-368-5647 or on the Internet at: <http://www.cgaux.org>
- U.S. Power Squadrons: 1-888-FOR-USPS (1-888-367-8777) or on the Internet at: <http://www.usps.org>

Warnings & Warning Labels

Warning Labels

⚠ DANGER
Carbon monoxide (CO) can cause brain damage or death.
Engine and generator exhaust contains odorless and colorless carbon monoxide gas.
Carbon monoxide will be around the back of the boat when engines or generators are running.
Move to fresh air if you feel nausea, headache, dizziness, or drowsiness.
NW-206-05
1811367

⚠ CAUTION
DISENFECT AND FLUSH POTABLE WATER SYSTEM BEFORE USING.
FAILURE CAN CAUSE ILLNESS.
1703699

USE UNLEADED PETROL ONLY
65745
1704248

⚠ WARNING
FUEL VAPORS MAY EXPLODE.
INSPECT FUEL SYSTEM AT LEAST ANNUALLY.
62966A
1703701

⚠ WARNING
DO NOT ATTEMPT TO BOARD OR USE THE LADDER IF MOTOR IS RUNNING.
62962
1703700

⚠ WARNING
AVOID SERIOUS OR FATAL INJURY DUE TO ROTATION OF SEAT.
LOCK SWIVEL WHEN SPEED EXCEEDS 5 MPH.
1839736
1839736 (IF EQUIPPED)

⚠ WARNING
CARBON MONOXIDE HAZARD.
KEEP CLOSED WHEN RUNNING ENGINE OR GENERATOR.
1693520

⚠ WARNING
RISK OF FALLING HATCH
ENSURE USE OF SUPPORT ROD BEFORE ACCESSING AREA BELOW
FAILURE TO DO SO CAN RESULT IN SERIOUS INJURY OR DEATH
1813021

WARNING
Carbon monoxide (CO) can cause brain damage or death.
Engine and generator exhaust contains odorless and colorless carbon monoxide gas. Signs of carbon monoxide poisoning include nausea, headache, dizziness, drowsiness, and lack of consciousness.
Get fresh air if anyone shows signs of carbon monoxide poisoning.
See Owner's Manual for information regarding carbon monoxide poisoning.
1811368 NW-204-05

WARNING
TRIM TABS SHOULD BE USED FOR PORT TO STARBOARD TRIM ADJUSTMENT. EXCESSIVE DOWN TAB MAY RESULT IN POOR HANDLING CHARACTERISTICS. DO NOT RUN TABS DOWN IN FOLLOWING SEA CONDITIONS. 1704136

WARNING
ENGINE COMPARTMENT HAS FIXED FIRE EXTINGUISHING SYSTEM. BEFORE DISCHARGING FIRE EXTINGUISHER:
1. SHUTDOWN ENGINES AND BLOWERS
2. EVACUATE THE ENGINE COMPARTMENT TO AVOID ASPHYXIATION.
AFTER DISCHARGE VENTILATE ENGINE COMPARTMENT BEFORE ENTERING. 1706555 79941

WARNING
DO NOT BOARD FOREDECK WHEN BOAT IS UNDERWAY. CAN CAUSE INJURY OR DEATH. 62960 1703698

WARNING
CARBON MONOXIDE HAZARD. KEEP CLOSED WHEN RUNNING ENGINE OR GENERATOR. 1693520

WARNING
ATTACH SHUT DOWN SWITCH LANYARD TO QUALIFIED OPERATOR WHILE ENGINE IS IN OPERATION. UNCONTROLLED BOAT MAY CAUSE INJURY OR DEATH. READ OWNER'S MANUAL BEFORE USE. 1703581

WARNING
GASOLINE VAPORS CAN EXPLODE. BEFORE STARTING, OPERATE BLOWER 4 MINUTES. CHECK ENGINE COMPARTMENT BILGE FOR FUEL VAPORS. RUN BLOWER BELOW CRUISING SPEED. 1704247

CAUTION
BEFORE PUMPING, INSURE BOAT IS IN LEGAL WASTE DISCHARGE AREA AND WASTE THRU HULL SEACOCK IS OPEN. DO NOT CONTINUE PUMPING AFTER TANK IS EMPTY. 1705252 1705252 (IF EQUIPPED)

Sliding Entry Door Warning

! WARNING!
PERSONAL INJURY and/or PRODUCT or PROPERTY DAMAGE HAZARD!
Before getting underway, make sure the entry door is closed and securely latched.

! WARNING!
PERSONAL INJURY and/or PRODUCT or PROPERTY DAMAGE HAZARD!
When the entry door is open, lock the door in the open position with the door stop to prevent the door from closing and causing injury.

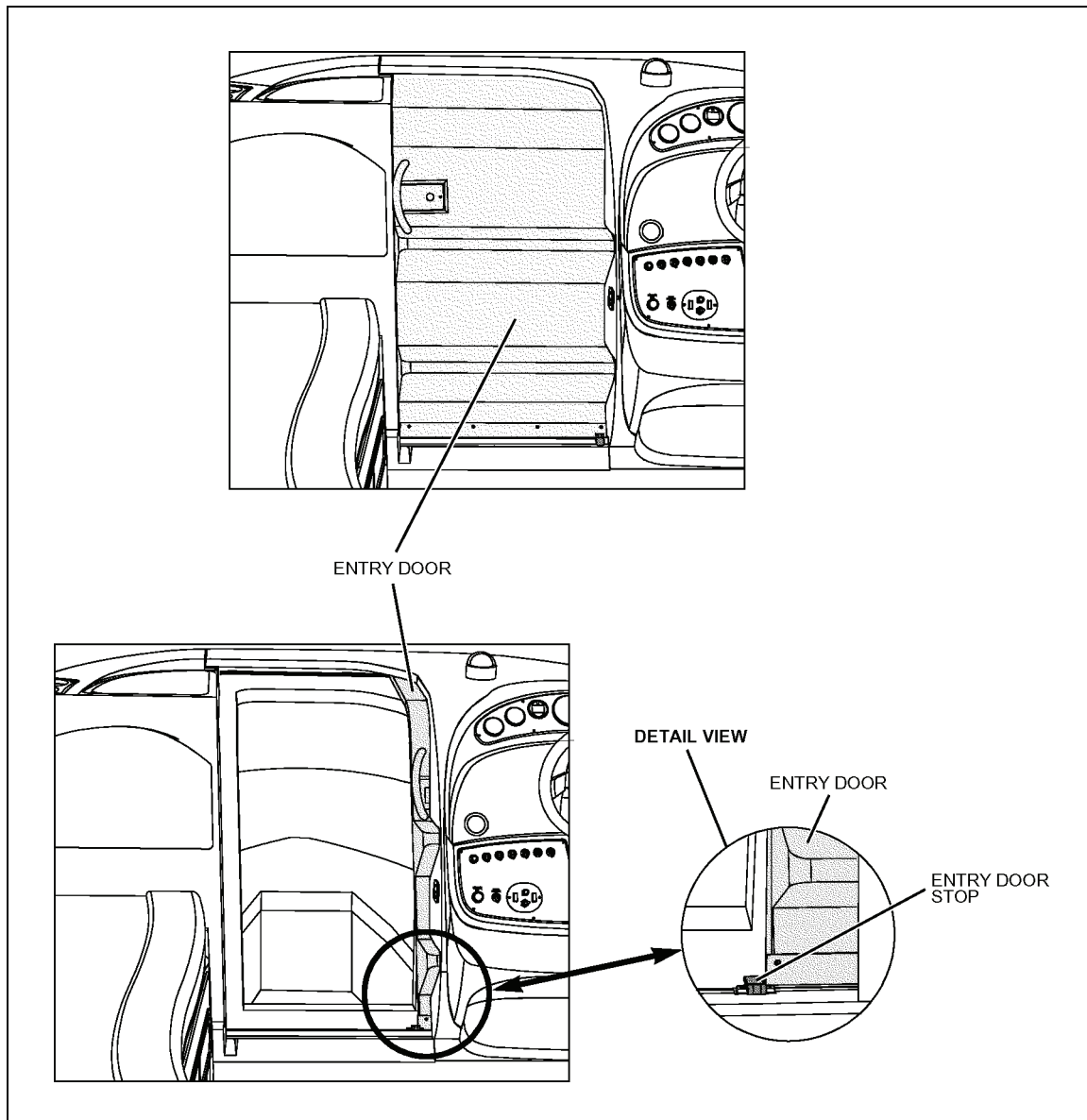

Chapter 2: Locations

Exterior Views

Hull Views

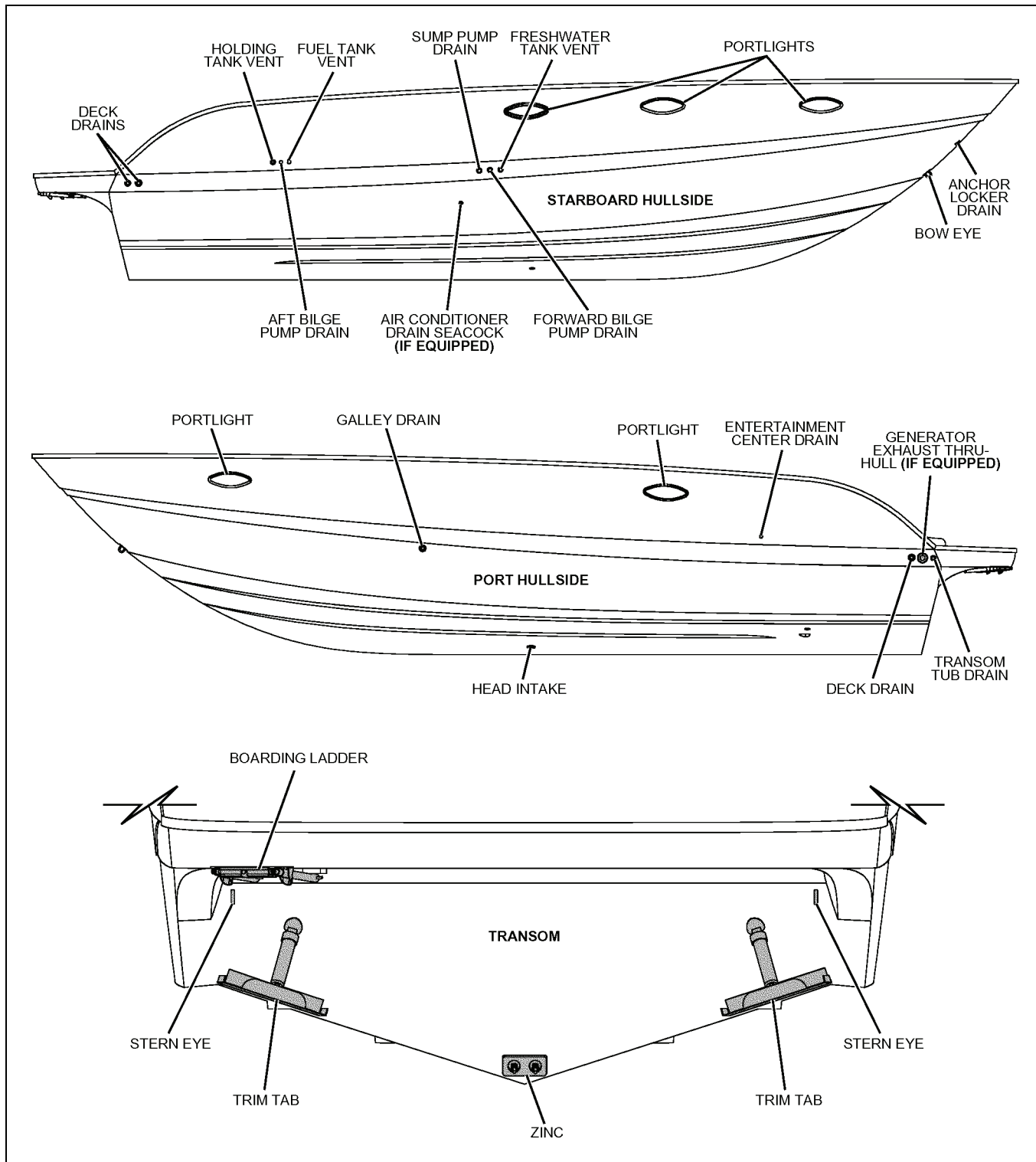

Deck Views

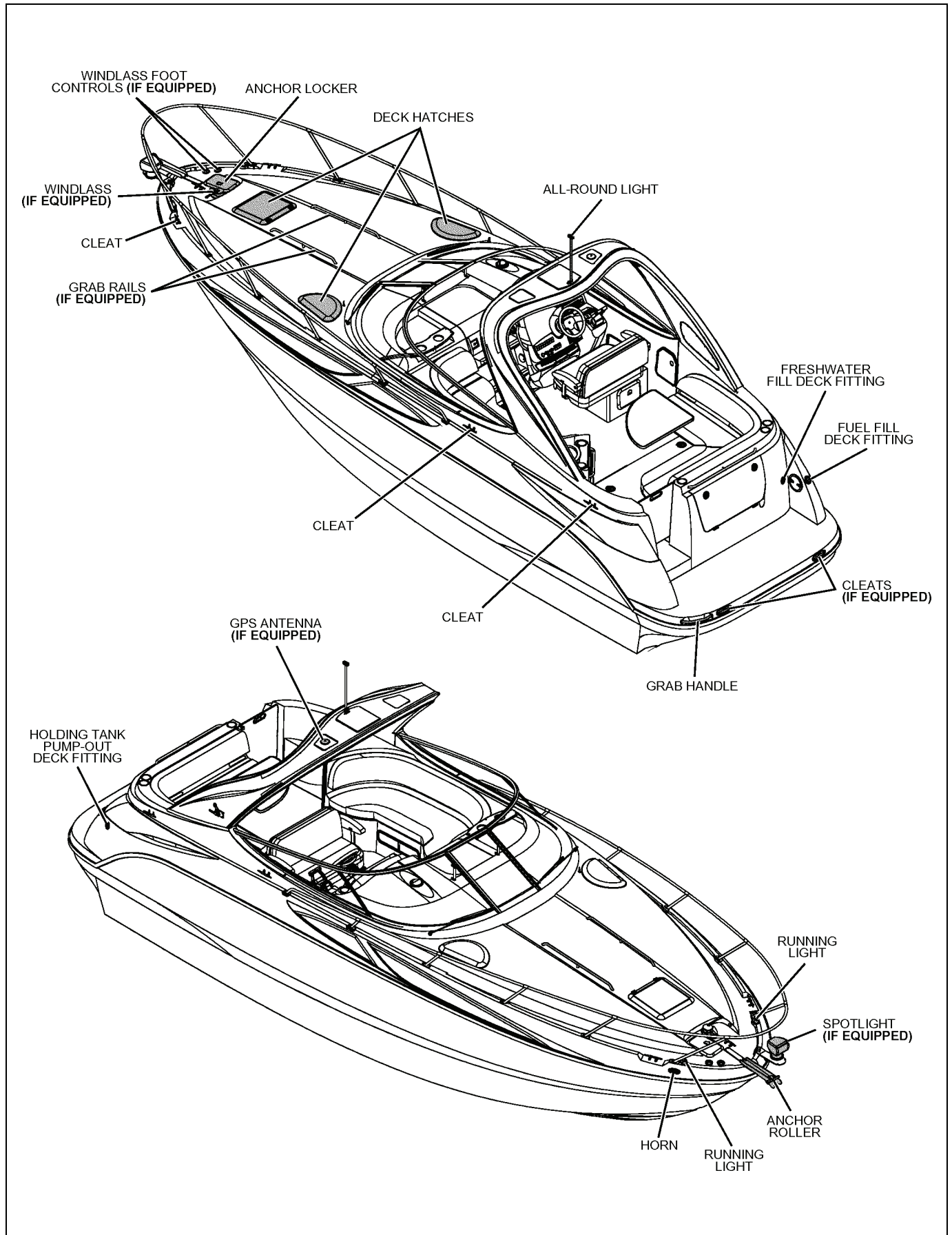

Helm

NOTE: TYPICAL HELM LAYOUT SHOWN. ACTUAL LAYOUT MAY VARY DEPENDING ON ENGINE AND ACCESSORY OPTIONS.

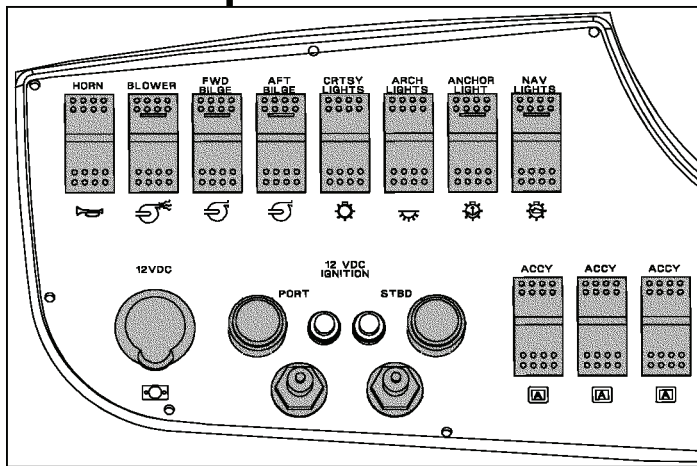
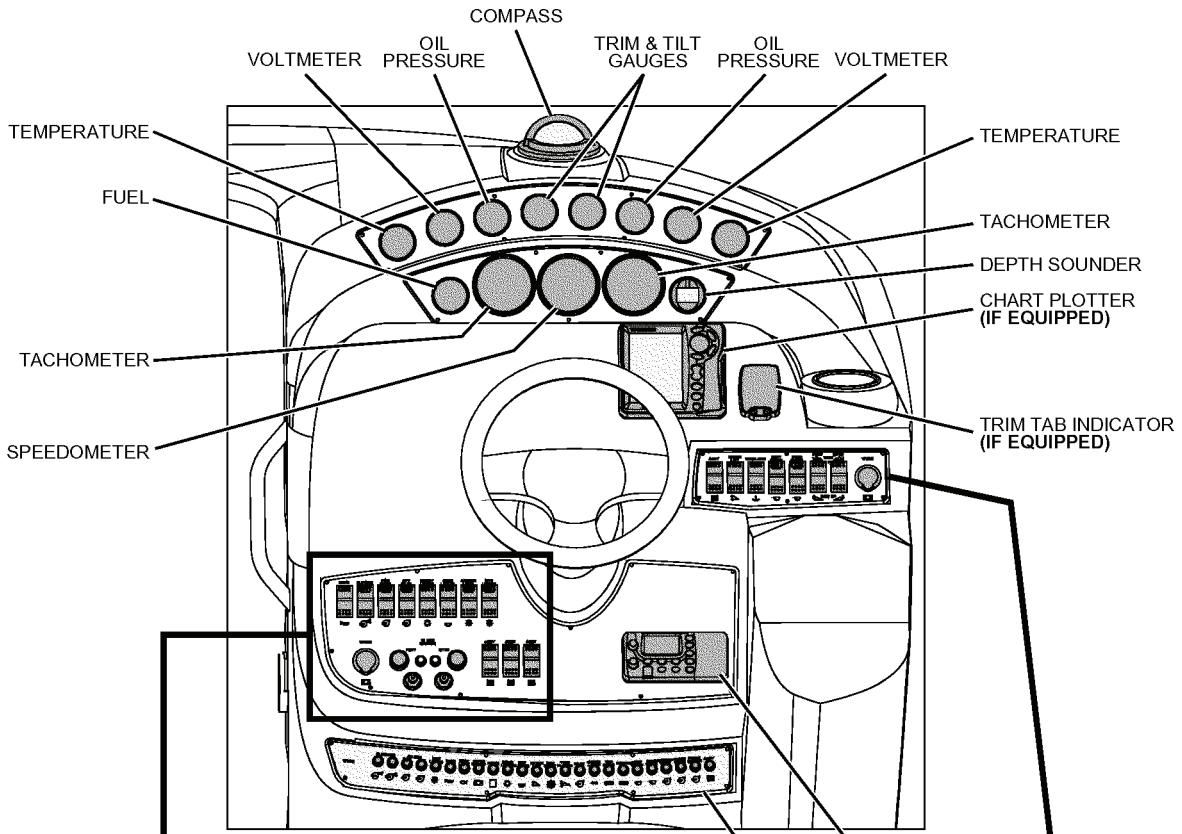

VHF RADIO (IF EQUIPPED)
12-VOLT DC PUSH-TO-REST CIRCUIT BREAKERS

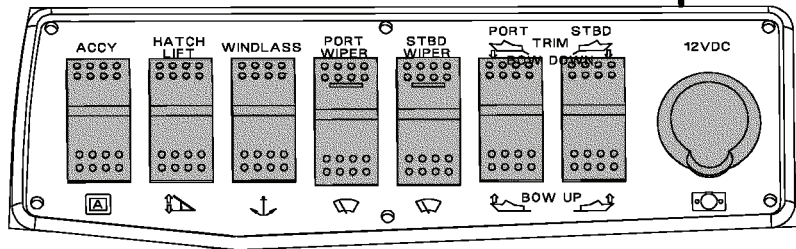

Component Locations

12-Volt DC Accessory Outlets (3 Total):

- Two are located at the helm.

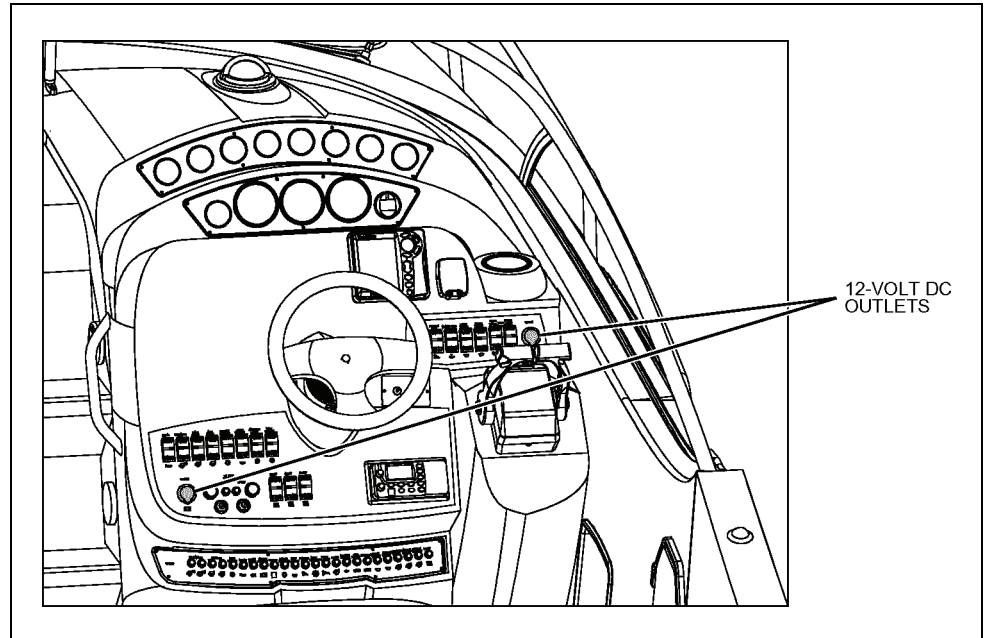

- One is located on the forward end of the galley.

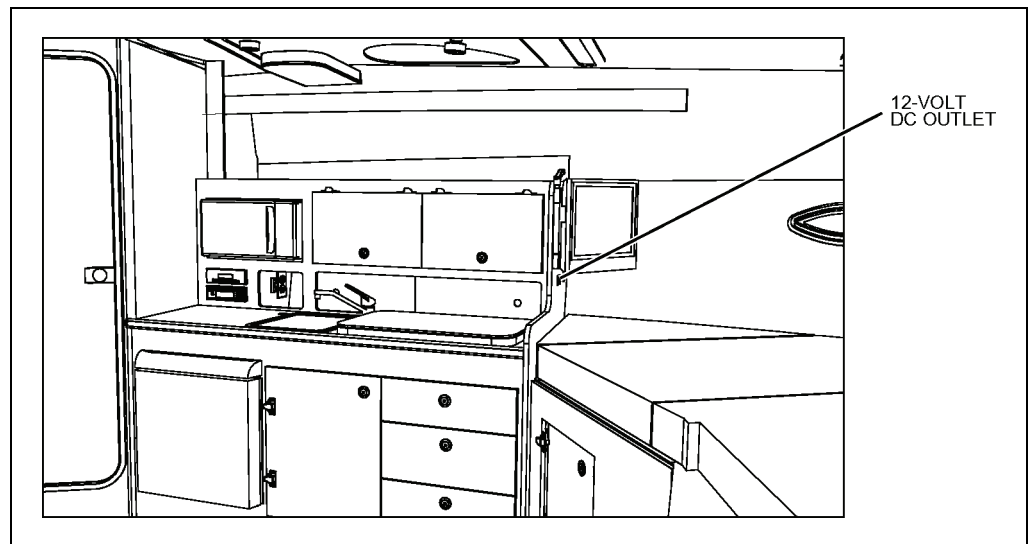

12-Volt DC Circuit Breakers (2 Locations):

- The 12-volt DC push-to-reset circuit breakers are located at the helm.

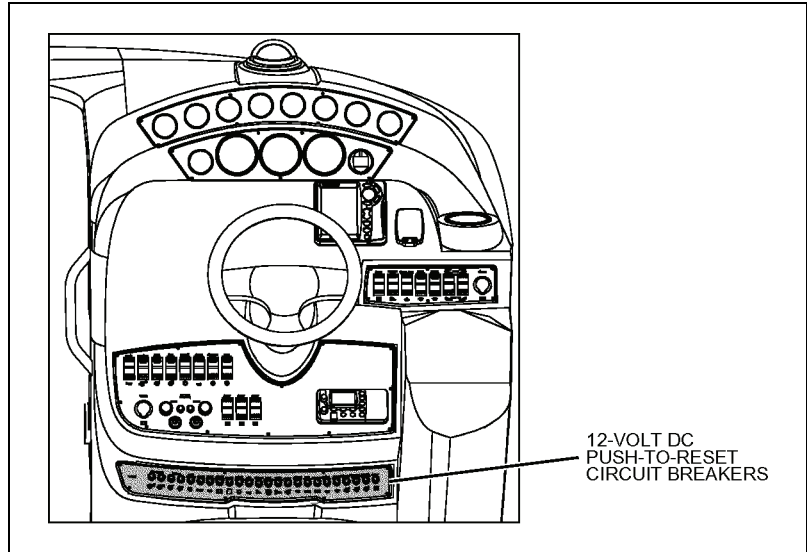

- The 12-volt DC main circuit breaker switch and standby-load push-to-reset circuit breakers are located on the battery switch panel.

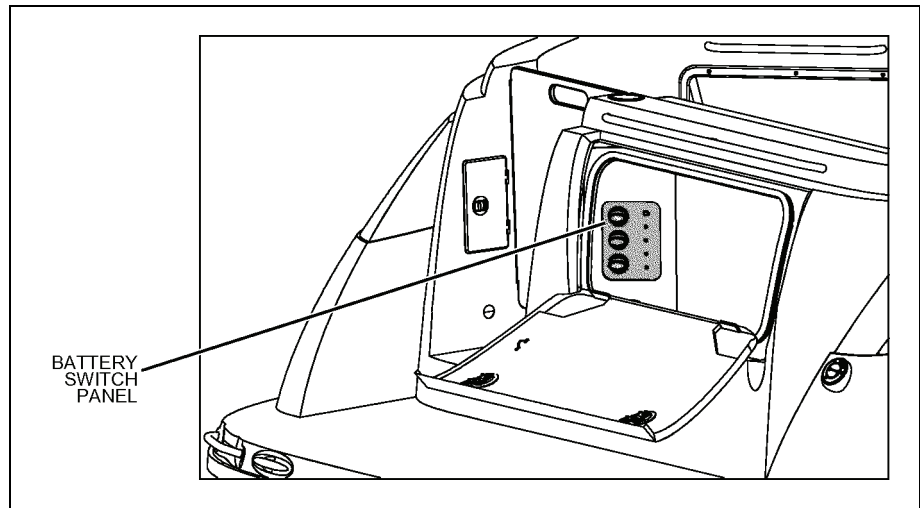

110-Volt AC Master Panel: Located just inside the aft berth.

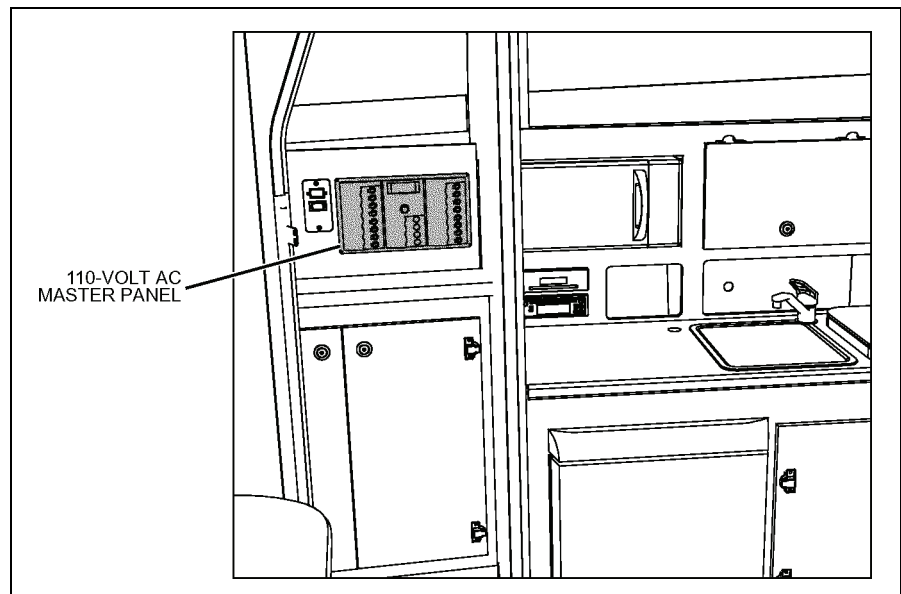

Air Conditioner (If Equipped):
Access through the starboard aft wall cutout in the aft-berth.

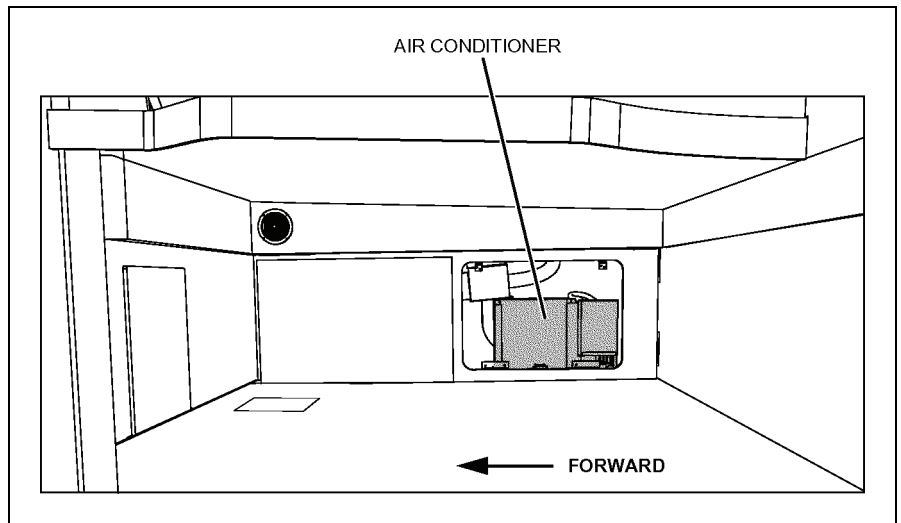

Air Conditioner Seawater Intake Seacock (If Equipped): Located in the engine room.

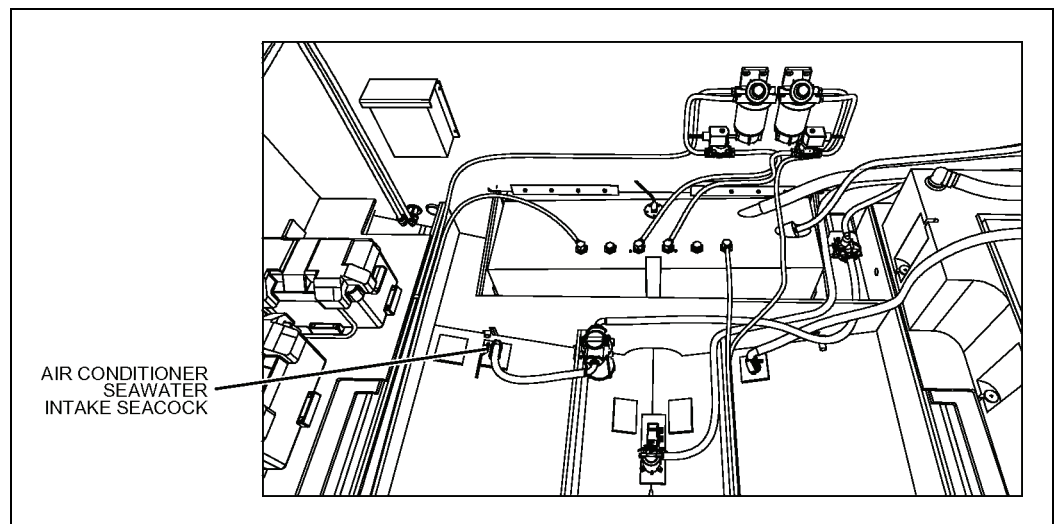

Batteries: Located on the port side of the engine room.

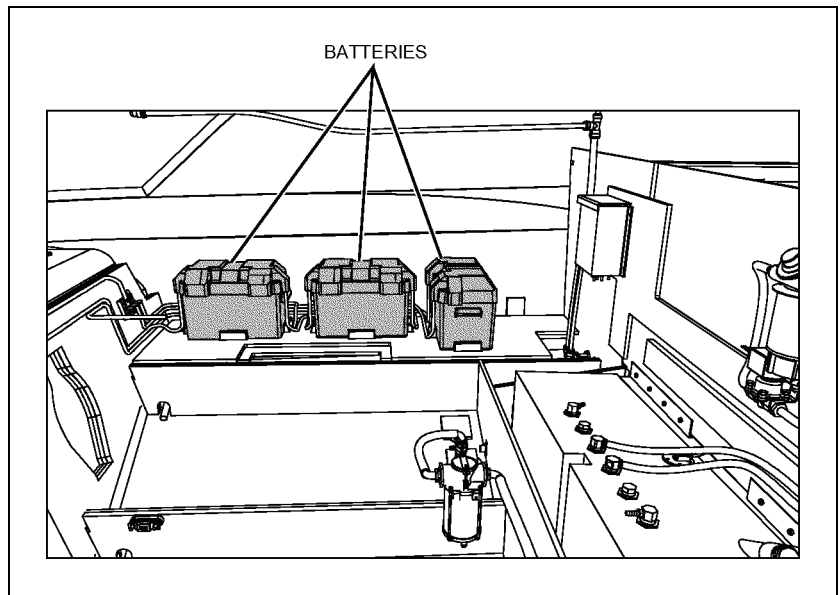

Battery Charger: Located on the port side of the engine room, on the forward wall.

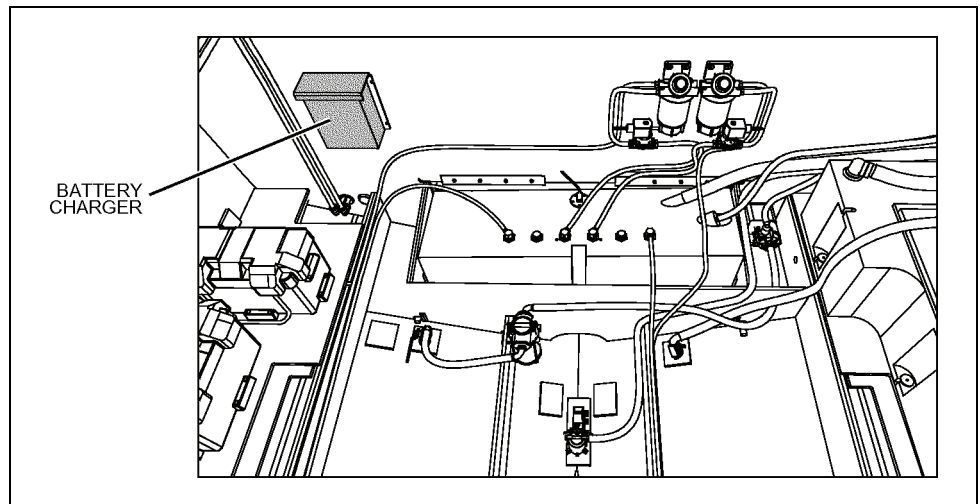

Battery Switches: Located inside the transom storage hatch.

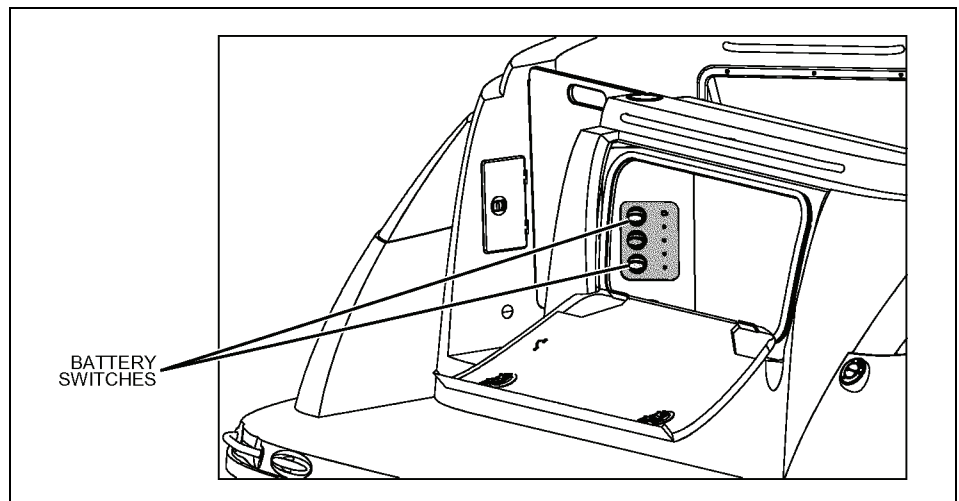

Bilge Pumps (2 Total):

- The aft bilge pump is located in the engine room bilge.

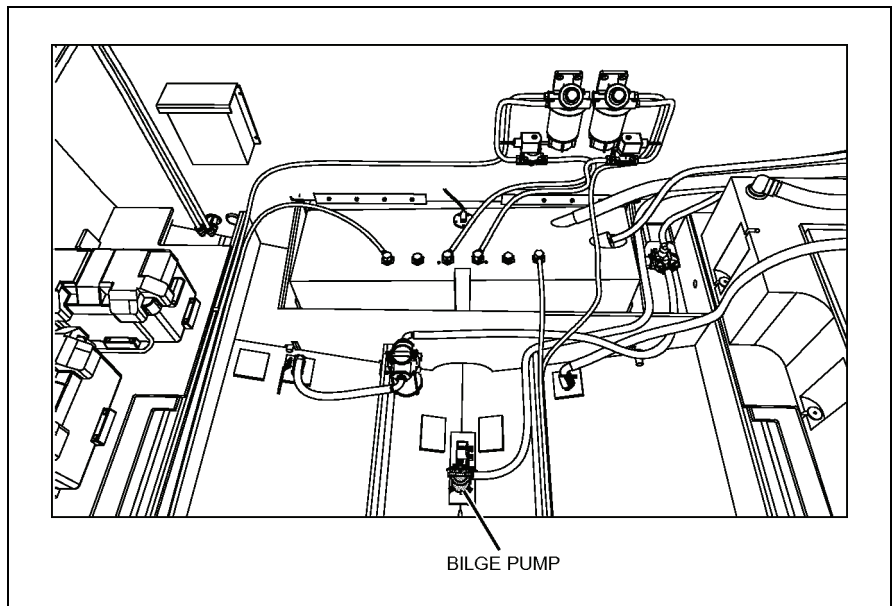

- The forward bilge pump is located under the bottom entry step.

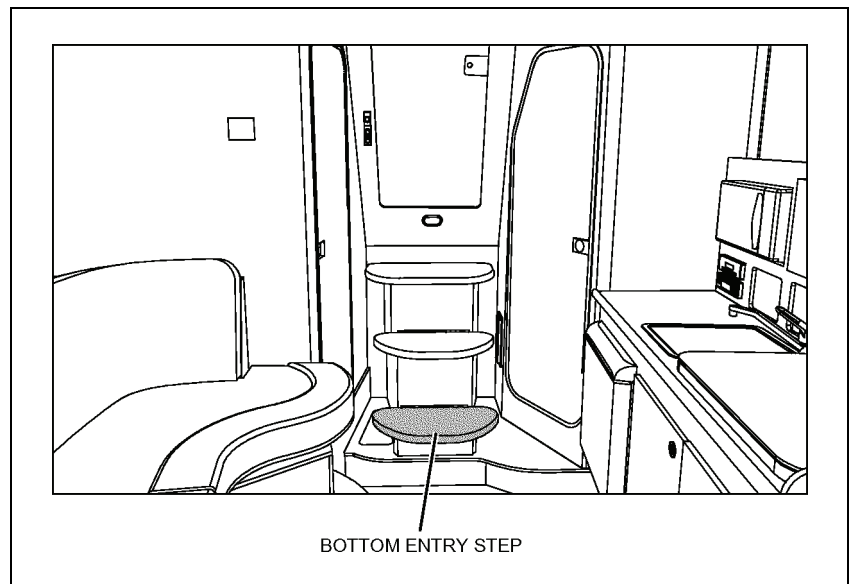

Blower Switch: Located on the lower switch panel at the helm.

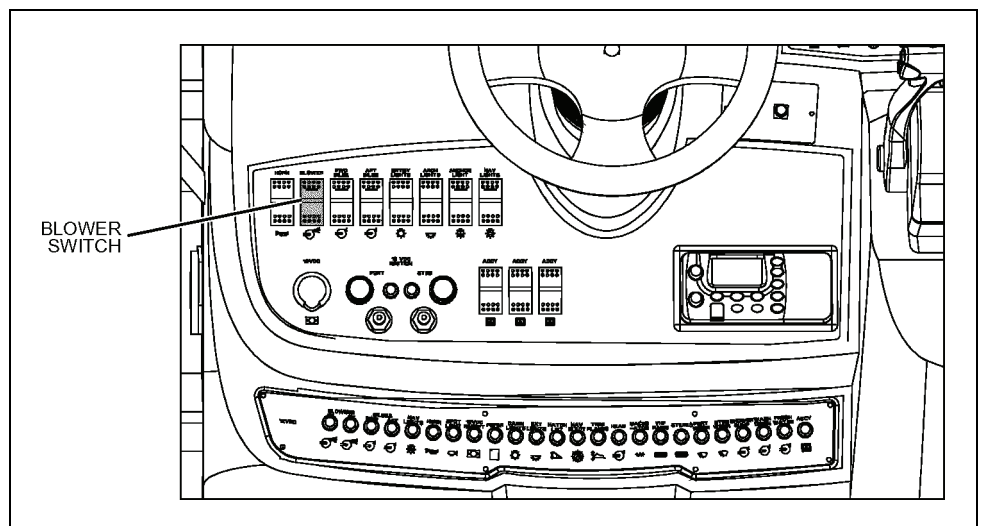

CO Monitors (2 Total):

- One is located on the ceiling above the dinette.

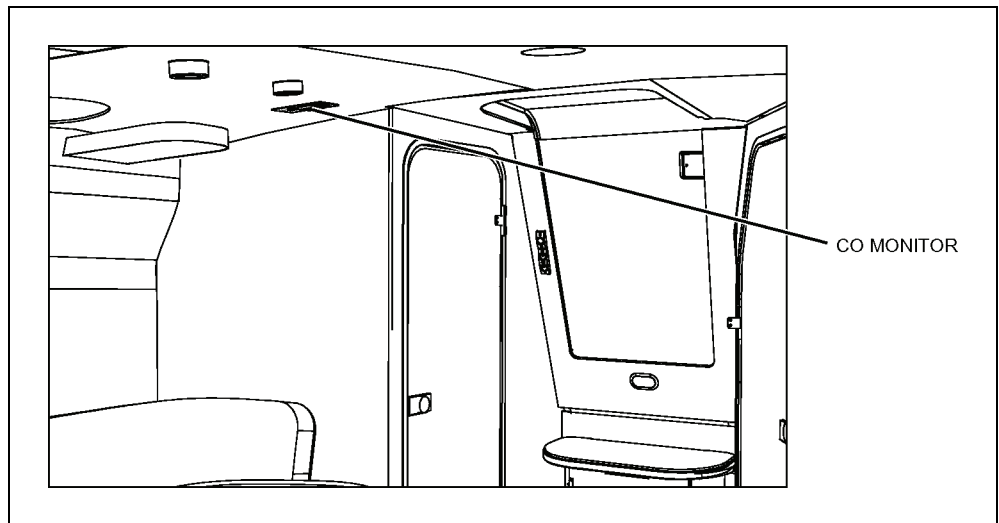

- One is located on the aft wall in the aft berth.

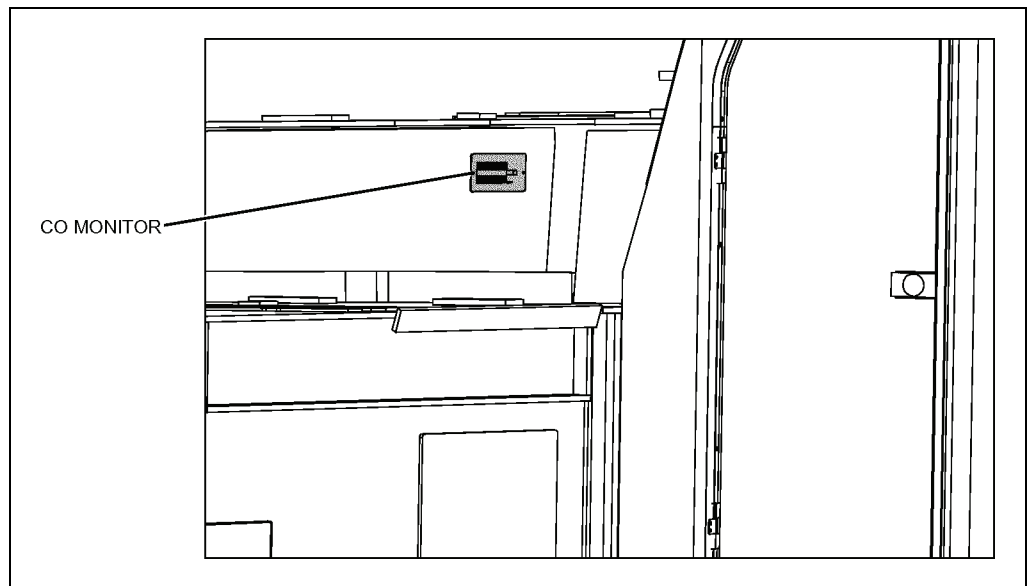

Depth Finder Transducer: Access through the forward wall hatch in the aft berth.

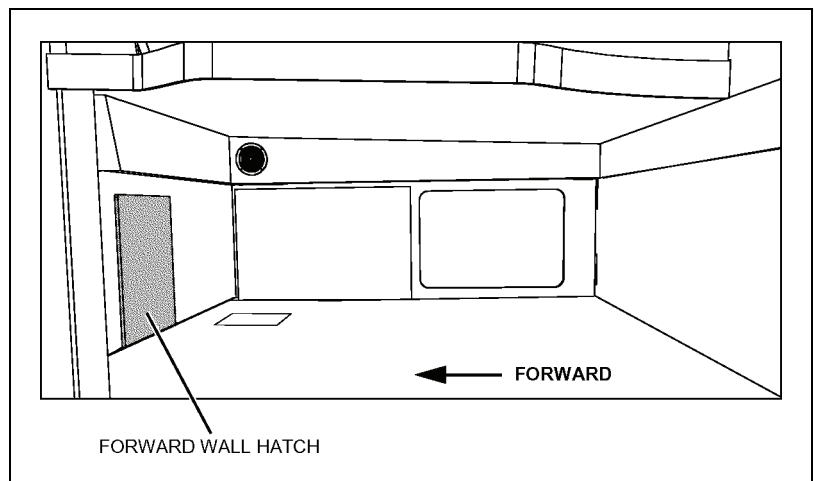

Electronic Fuel Shut-off Valves (Diesel Engines Only): Located on the forward wall of the engine room.

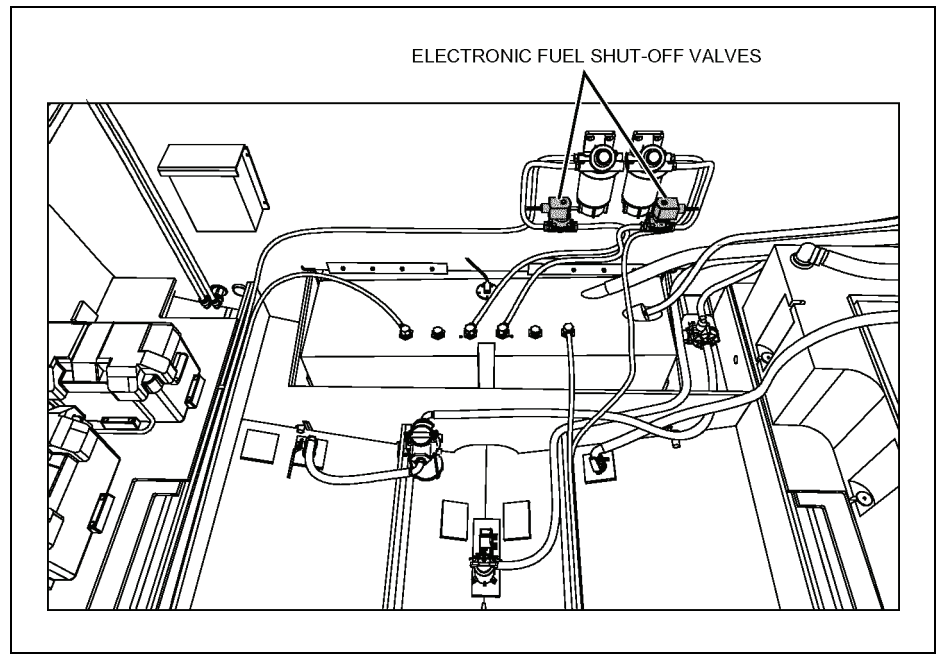

Engine Hatch Hydraulic Lift Pump & Fluid Reservoir (If Equipped): Located on the forward wall of the engine room.

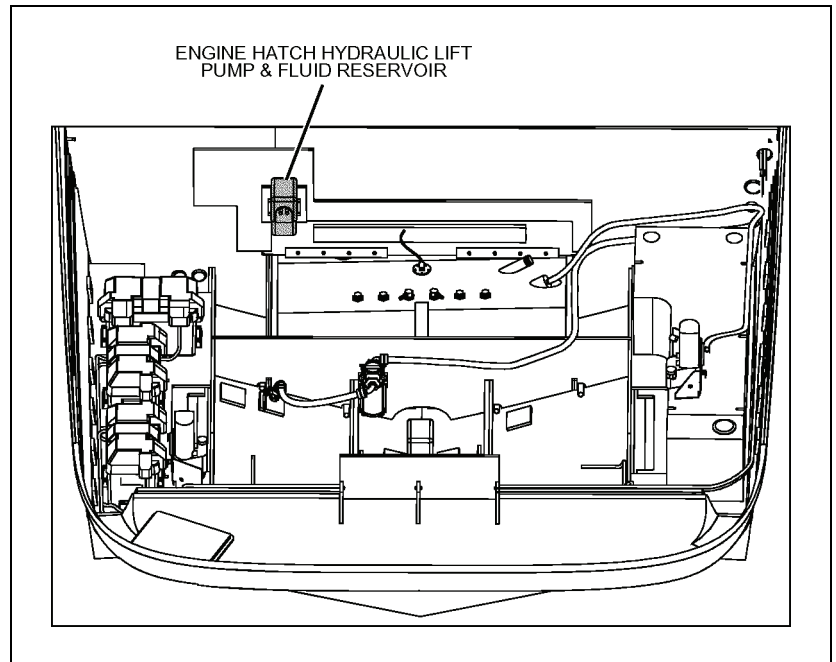

Fixed Fire Extinguisher (If Equipped):
Located in the starboard forward corner of the engine room.

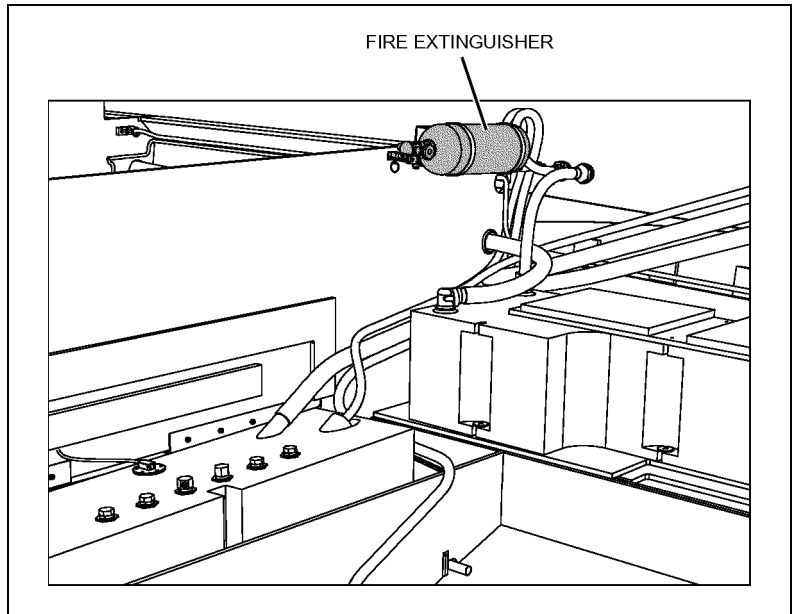

Freshwater Fill Deck Fitting (marked WATER): Located on the aft deck.

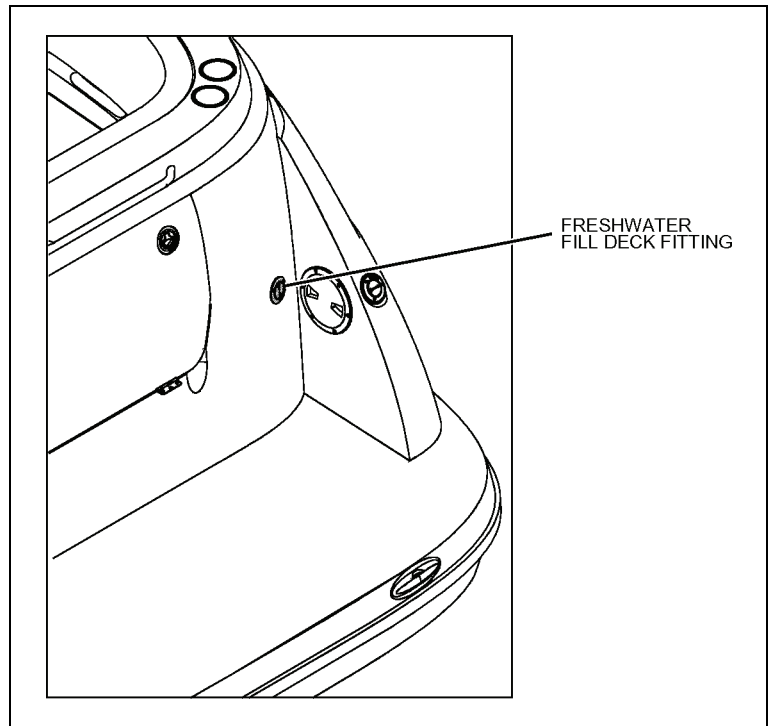

Freshwater Pump: Access through the forward wall hatch in the aft berth.

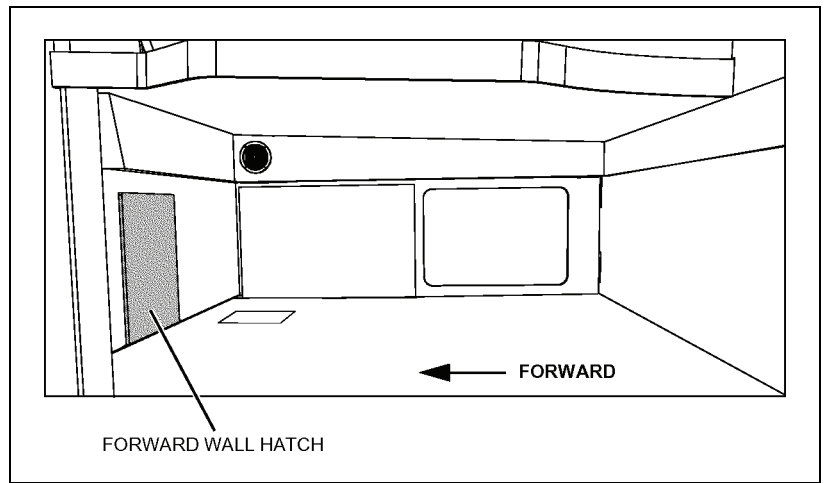

Freshwater Pump Switch: Located in the galley, just aft of the sink.

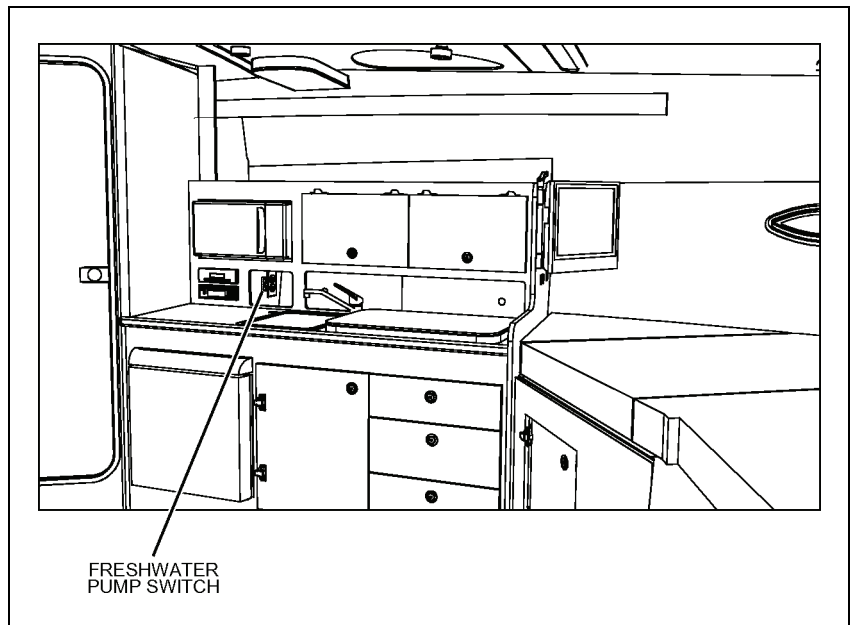

Freshwater Tank: Access through the cutout underneath the aft berth mattress.

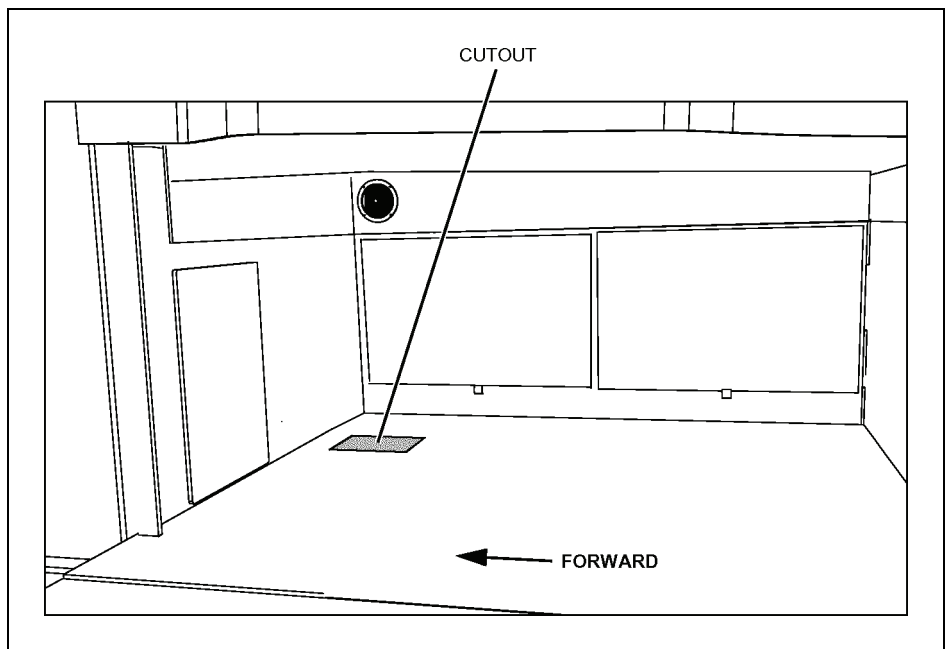

Fuel Tank: Access to the tank fittings is in the forward area of the engine room.

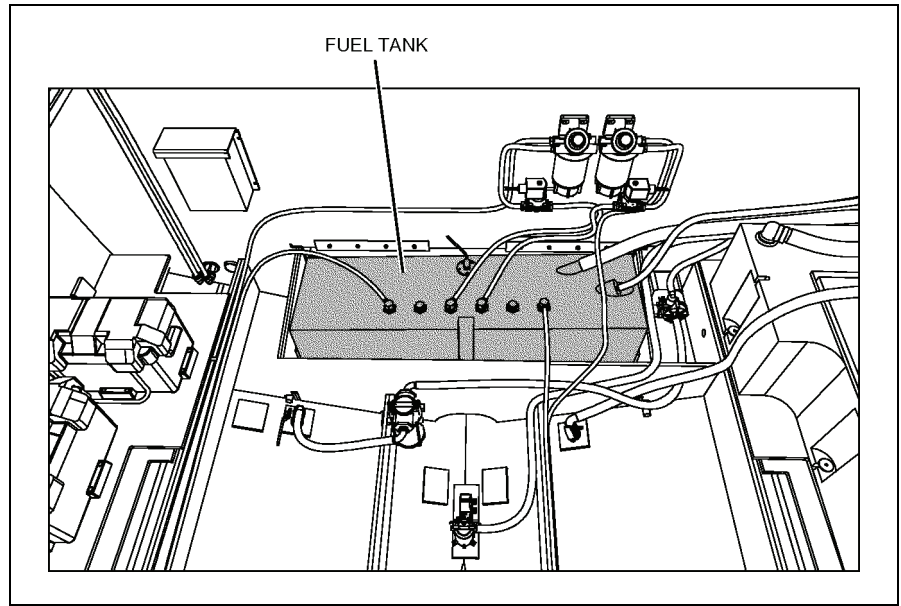

Fuel Fill Deck Fitting (marked GAS or DIESEL): Located on the starboard aft corner of the deck.

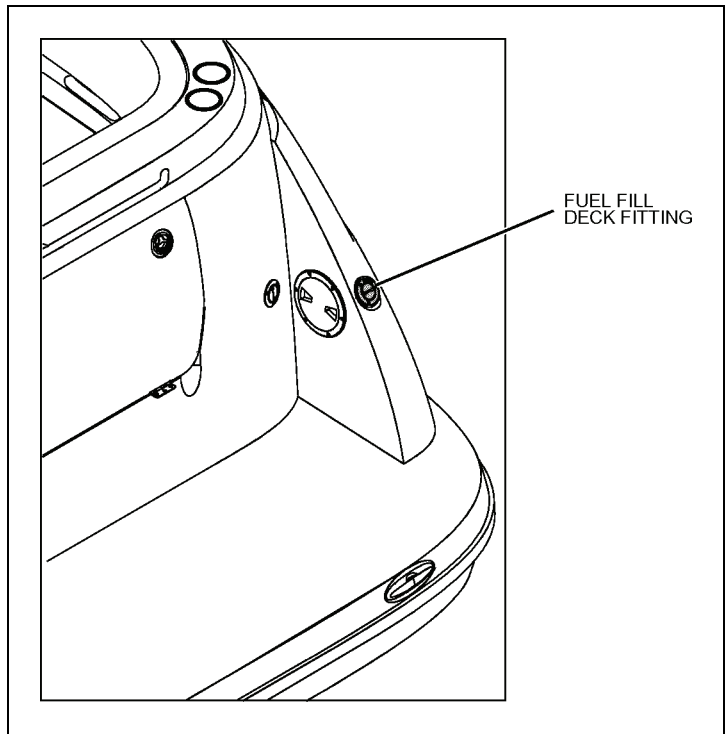

Generator (If Equipped):
Located in the engine room

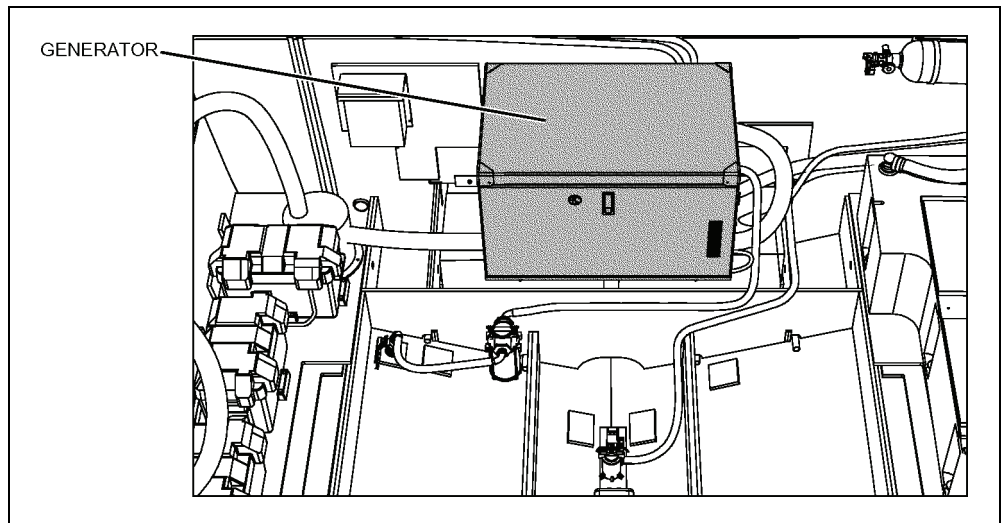

Generator Control Panel (If Equipped):
Located just inside the aft berth.

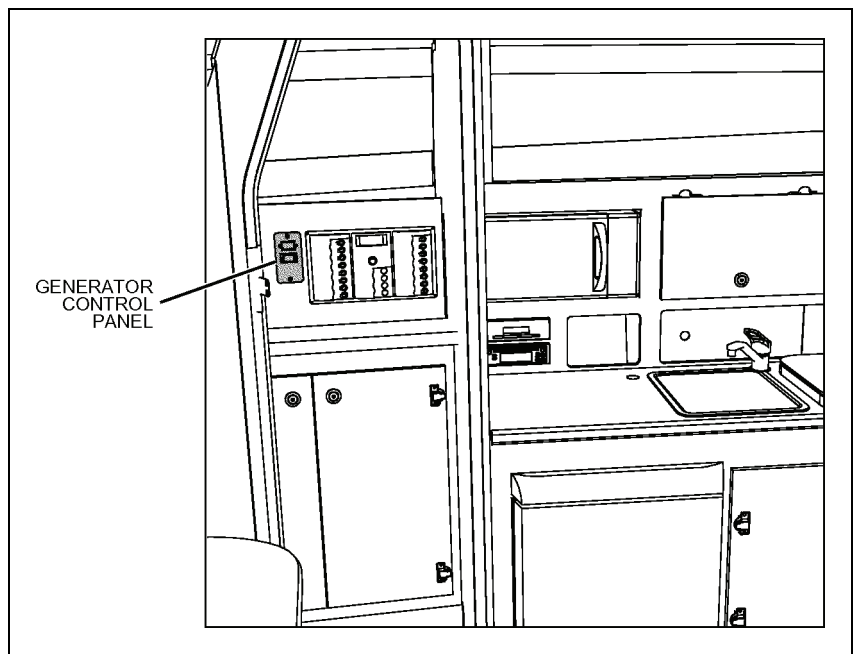

Generator Seawater Intake Seacock (If Equipped): Located in the engine room.

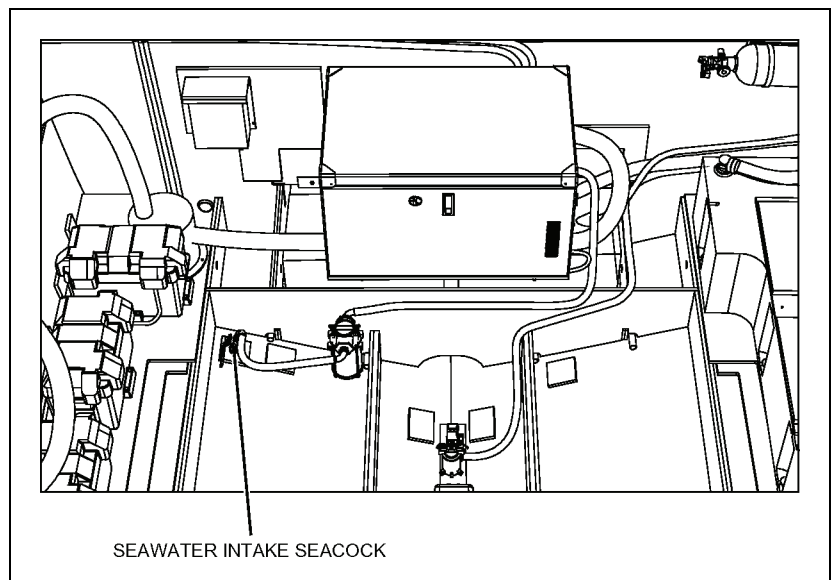

Holding Tank: Located on the starboard side of the engine room.

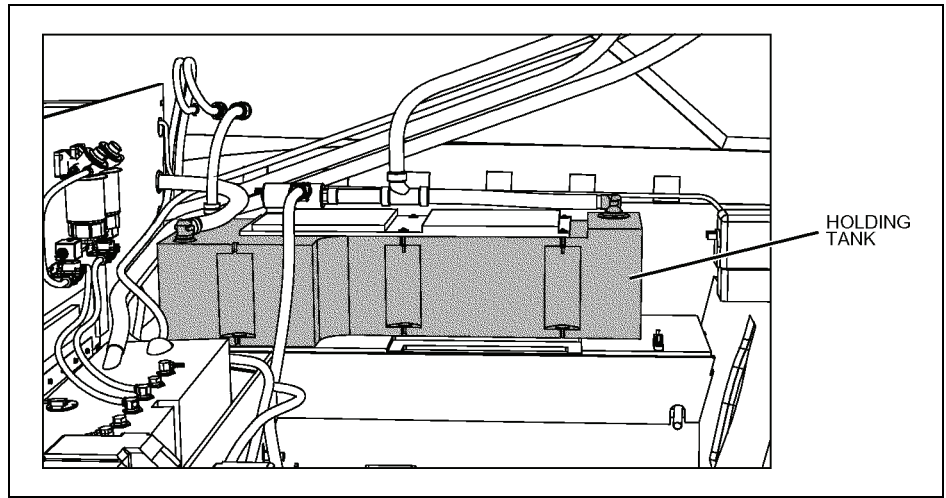

Holding Tank Pump-out Deck Fitting (marked WASTE): Located on the starboard aft corner of the deck.

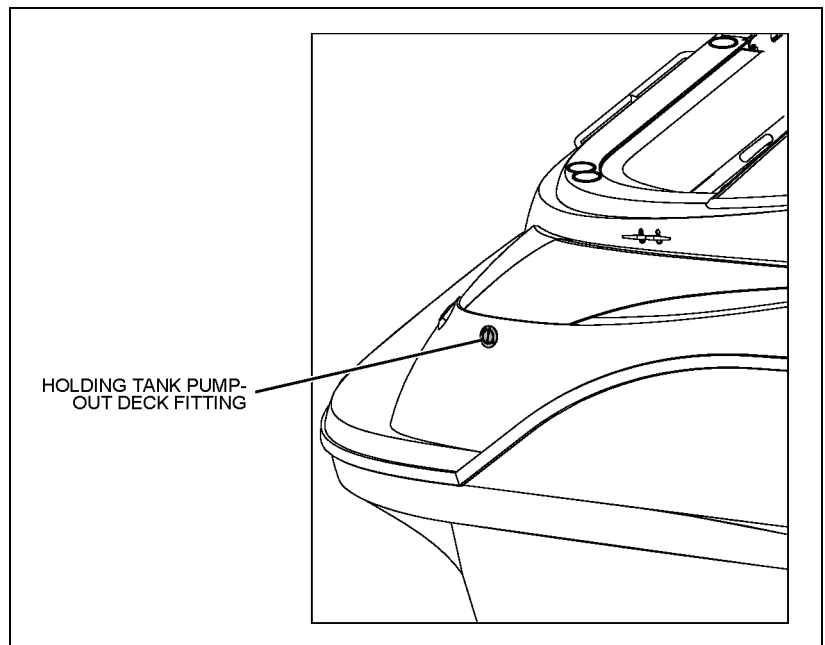

Macerator Switches (If Equipped): Located on the side panel next to the helm.

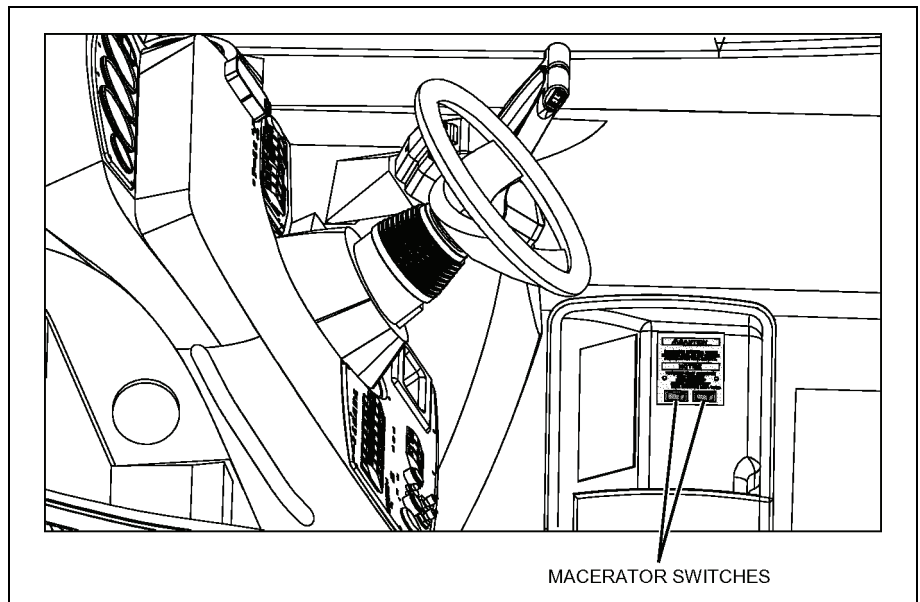

Macerator Underwater Discharge Seacock (If Equipped): Located in the engine room.

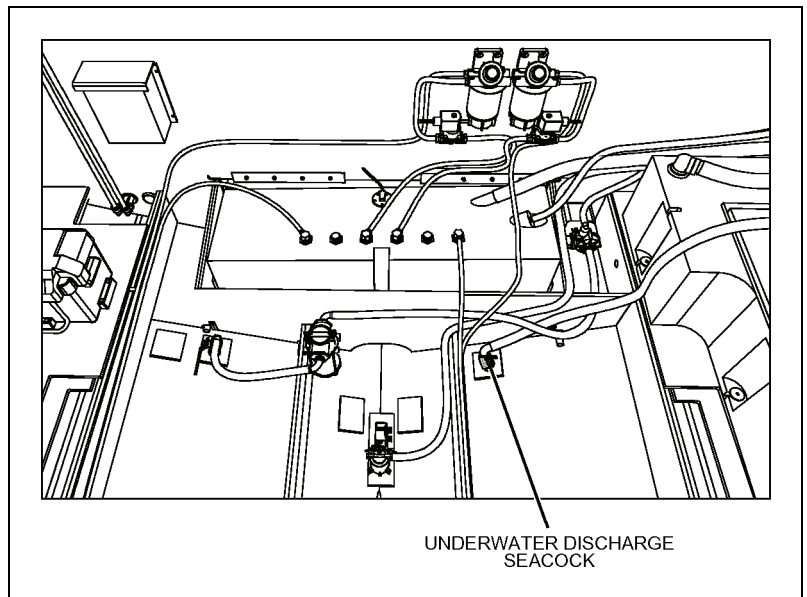

Marine Head (Electric) Seawater Intake Seacock (If Equipped): Located under the middle entry step.

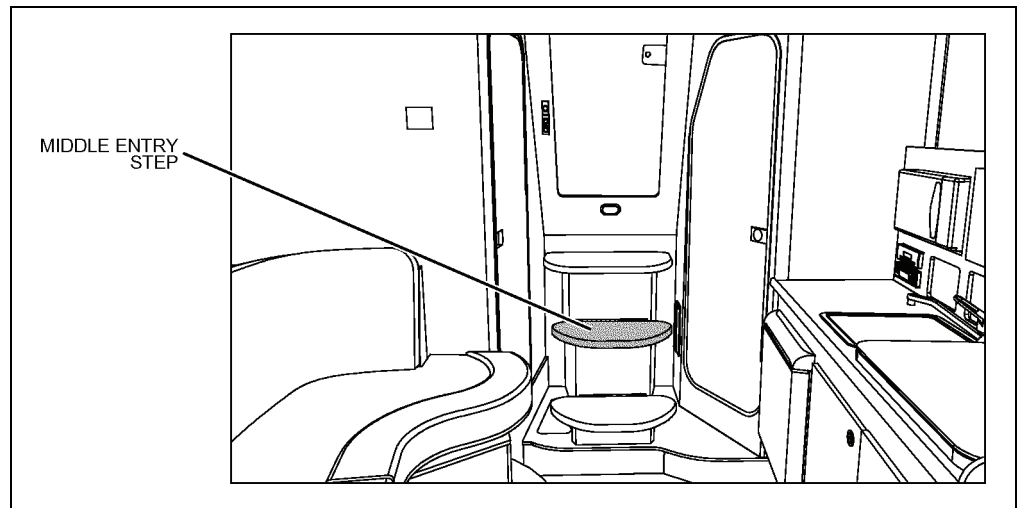

Navigation Lights: Red and green lights at the bow. White all-round light on the radar wing.

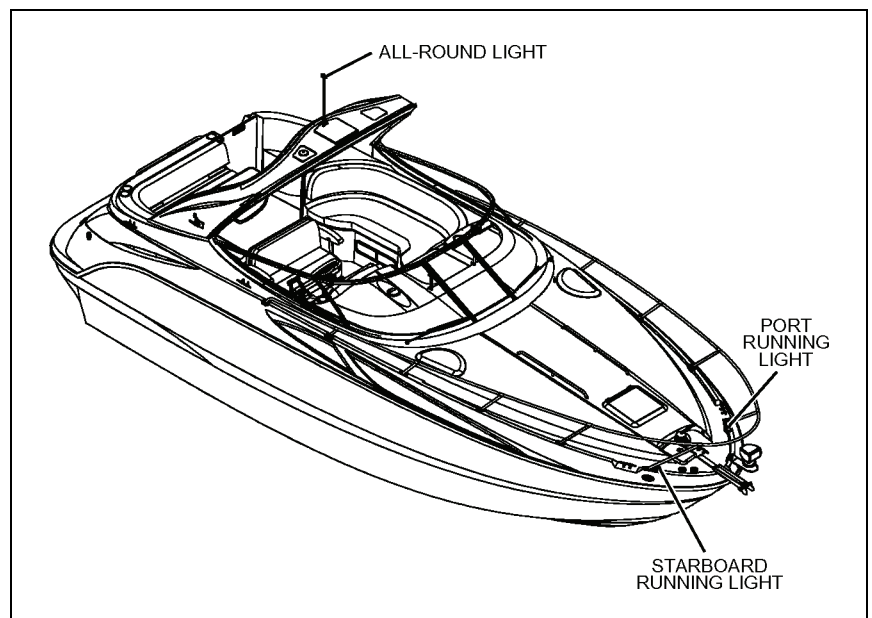

Shore Power Inlet(s): Located inside the transom storage hatch.

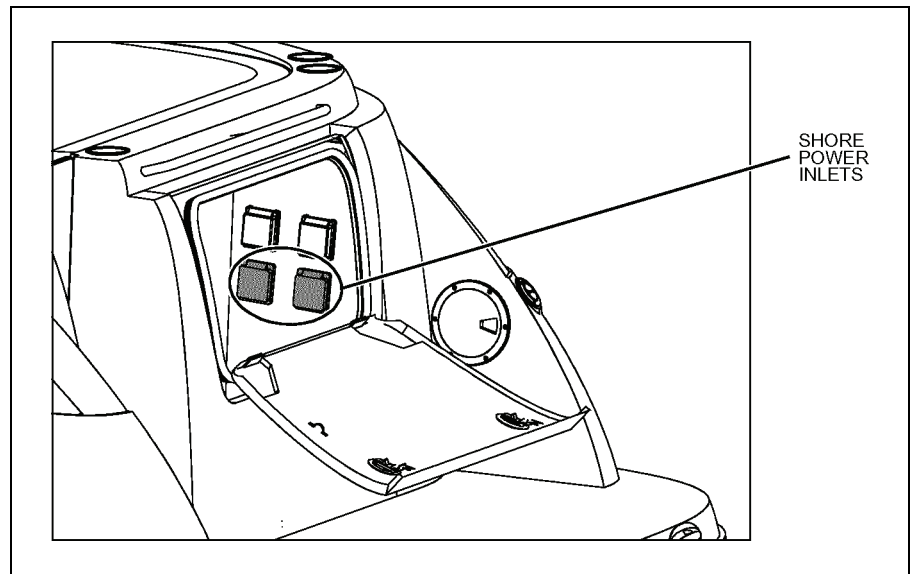

Shower Drain Sump Box: Located under the middle entry step.

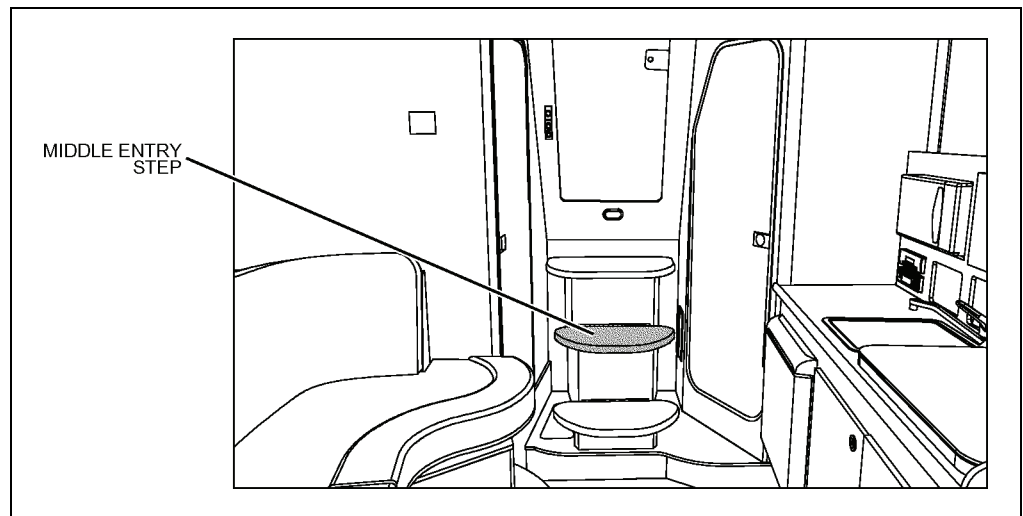

Transom Shower: Located just aft of the transom door.

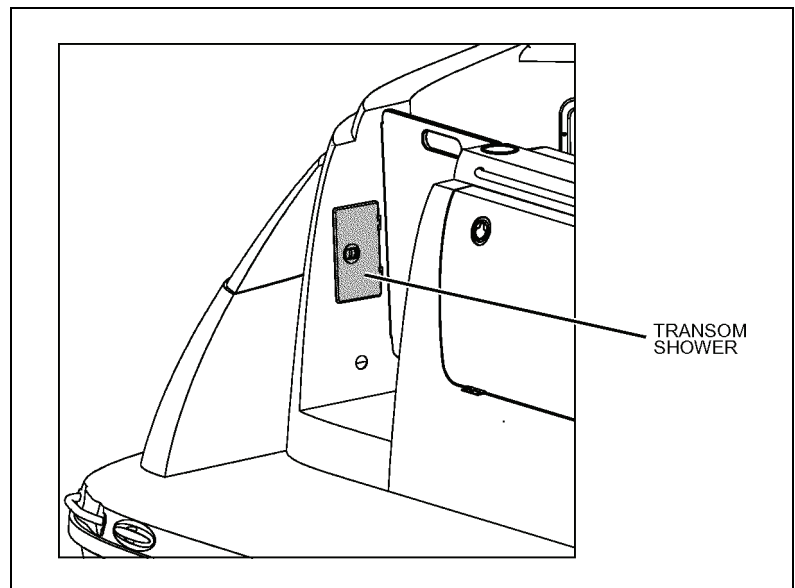

Trim Tab Hydraulic Pump & Fluid Reservoir: Located in the engine room, on the aft wall.

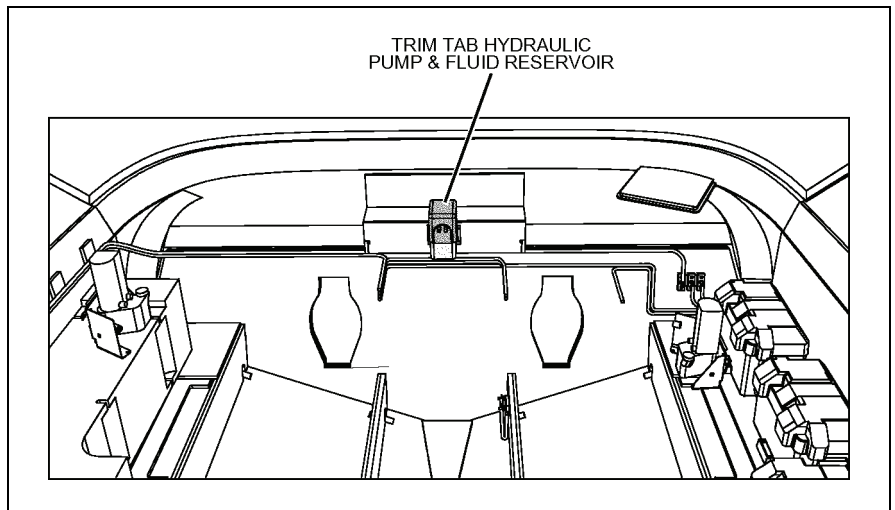

Trim Tab Switches: Located at the helm.

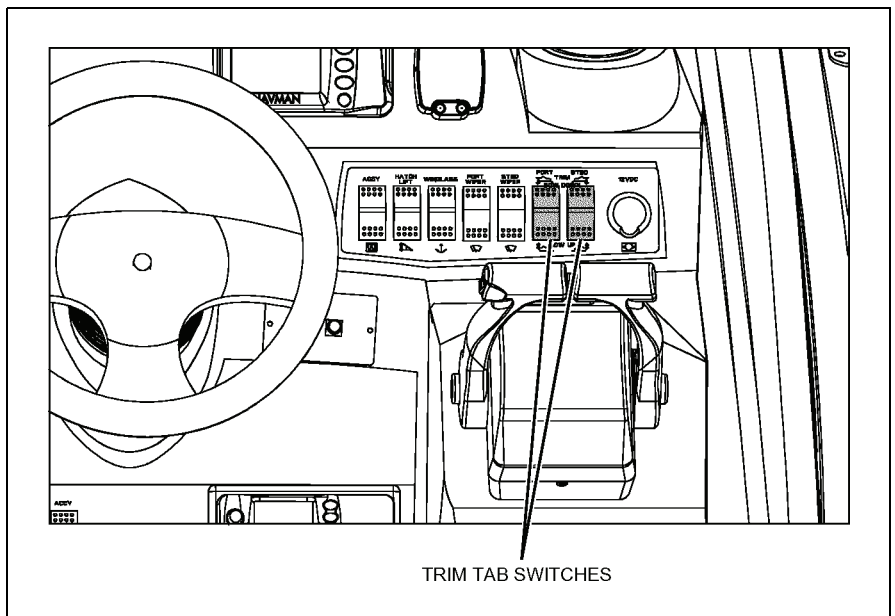

Trim & Tilt Pumps: Located on the port and starboard sides of the engine room.

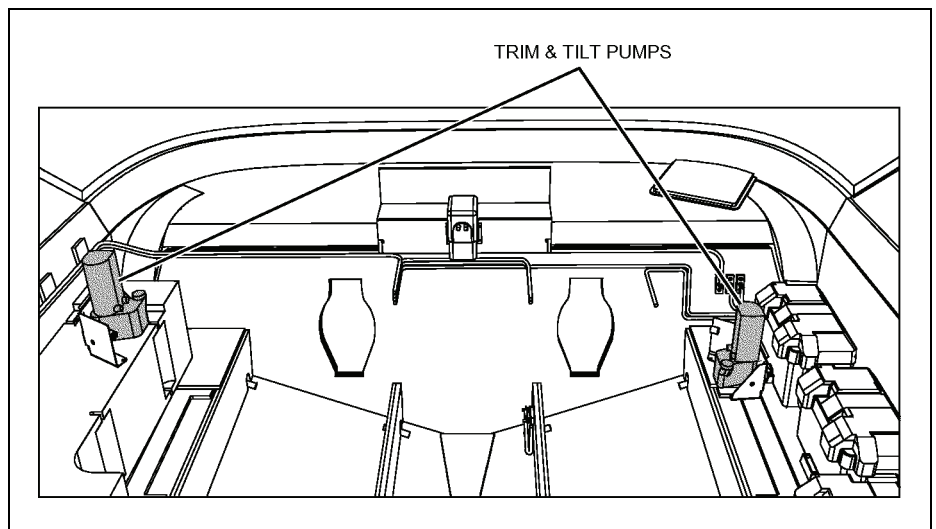

Water Heater: Access through the starboard forward wall cutout in the aft-berth.

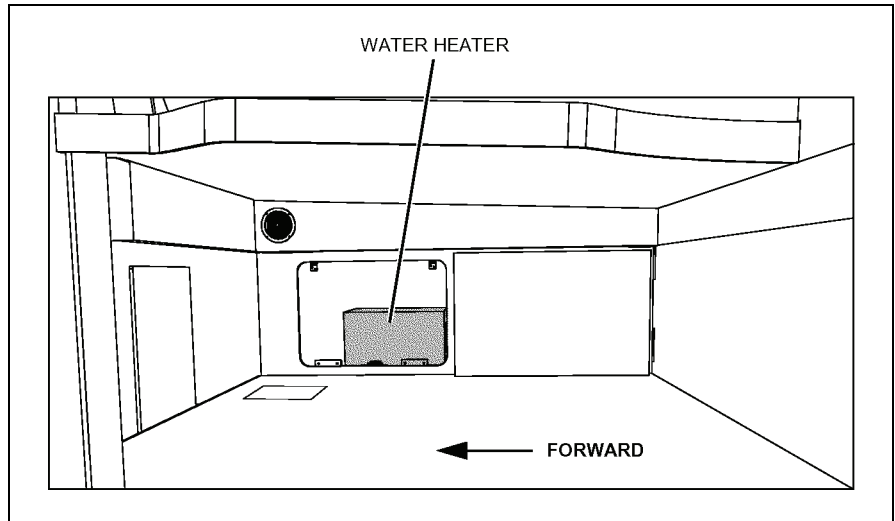

Windlass Circuit Breaker (If Equipped): Located inside the transom storage hatch.

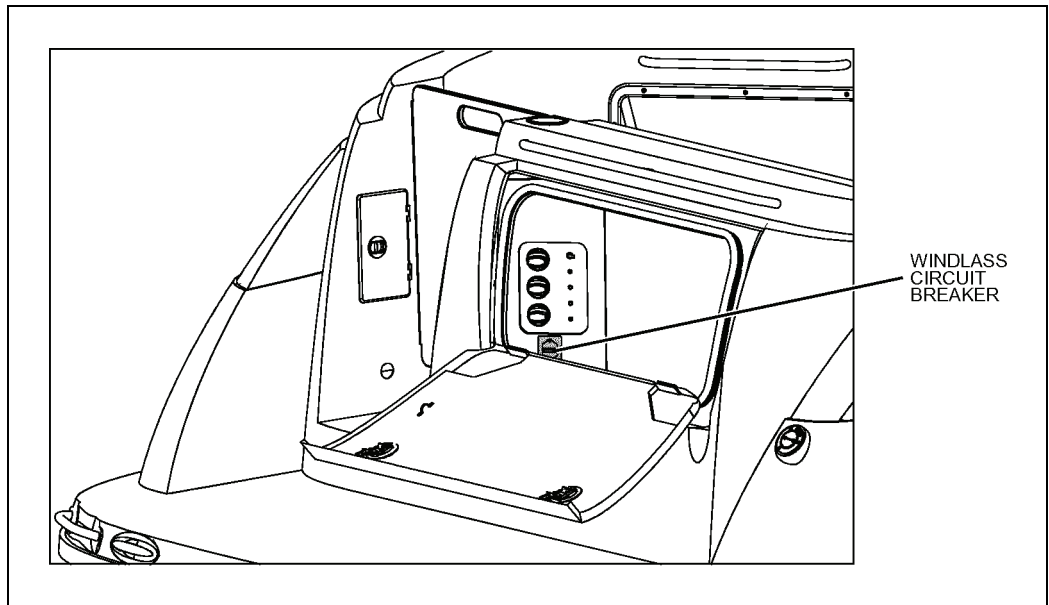

Windlass Foot Controls (If Equipped): Located in on the forward deck.

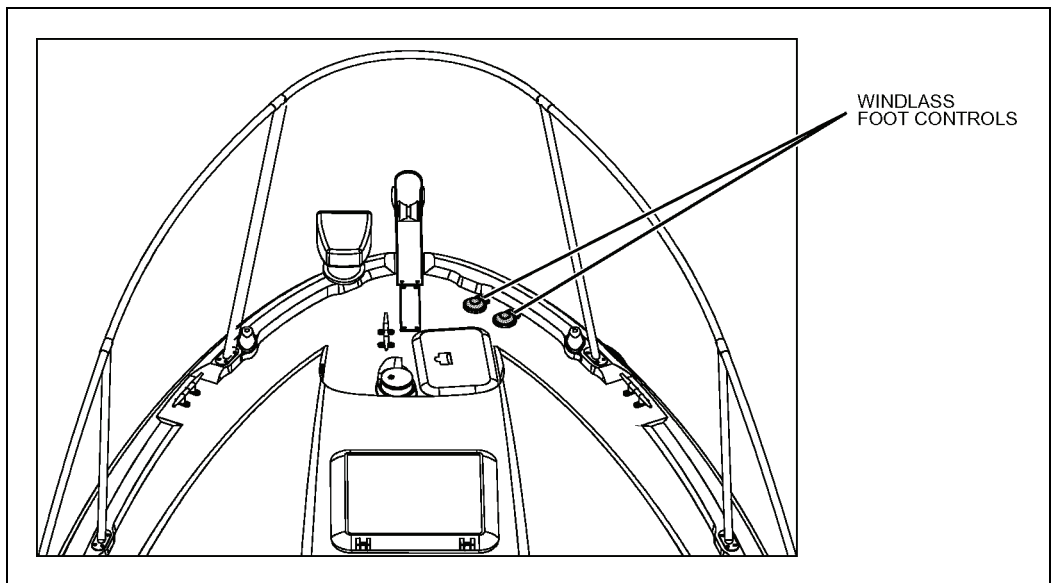

Chapter 3: Propulsion & Related Systems

Engines

NOTICE

Read the engine manual **BEFORE** starting or working on your engines.

While the topics listed below may be included in this *Owner's Manual Supplement* and in the *Cruiser & Yacht Owner's Manual*, **always** refer to the engine manual first for specific information on these important subjects:

- Engine Break-in Procedure
- Engine Starting and Stopping
- Gear Shifting
- Fuel and Oil Recommendations
- Engine Maintenance
- Engine Storage/Winterization

Bilge Blower System

⚠ **WARNING!**

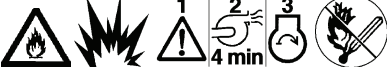

FIRE and EXPLOSION HAZARD!
Fuel vapors can explode! **BEFORE** starting the engines:

1. Check the bilge areas for fuel vapors or leaking fuel. If you see leaking fuel or smell fuel vapors:
 - a. Do **NOT** start the engines or generator, do **NOT** turn **On** any electrical devices, put out **ALL** cigarettes, cigars, and other sources of flame or ignition.
 - b. Get everyone off your boat.
 - c. Get trained help to find and fix the problem.
2. Run the bilge blowers for at least four minutes **BEFORE** engine starting, generator starting, electrical system work, or turning on electrical devices.
 - If you smell fuel vapors and the engines and/or generator are already running;
 - a. Shut **Off** the engines and/or generator, and turn **Off** **ALL** electrical devices.
 - b. Put out **ALL** cigarettes, cigars, and other sources of flame or ignition.
 - c. Get trained help to find and fix the problem.
 - **NEVER** obstruct or change the bilge blower system.

- The bilge blower system removes explosive fumes from the engine and bilge areas.
- Fresh air is drawn into the engine and bilge areas through the vents.

To make sure the engine and bilge areas are properly ventilated:

- Use the "sniff test" to check the engine and bilge areas for fuel vapors **before** starting the engines or the generator (if equipped).
- **Always** run the bilge blower system for at least four minutes **before** starting the engines or the generator (if equipped).
- Continue to run the bilge blower system until your boat has reached cruising speed.
- **Always** run the bilge blower system when running your boat below cruising speed.

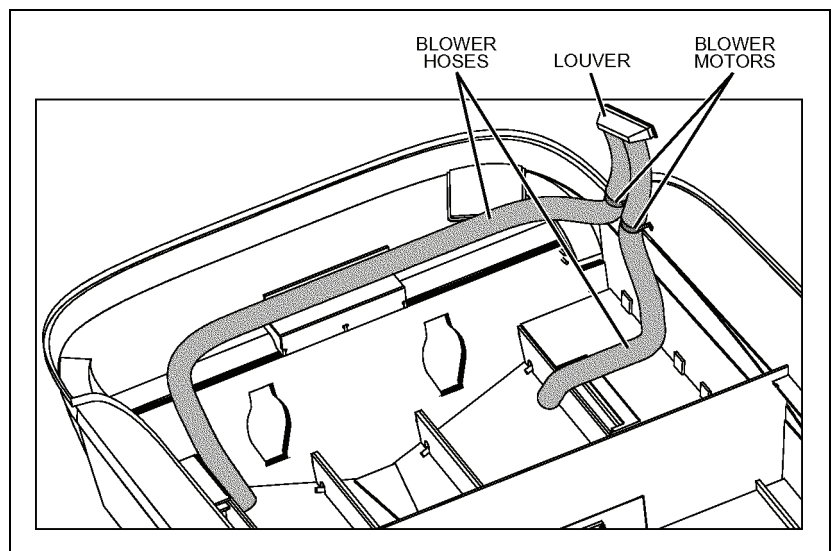

Engine Cooling Systems (If Equipped)

CAUTION

SYSTEM DAMAGE HAZARD!

- *Open* the engine cooling system's seacock or ball valve **BEFORE** starting the engine.
- Keep the engine cooling system's seacock or ball valve *Open* while the engine is running.

Gas Engine Cooling System

The gas engine cooling system circulates seawater through the engine to reduce engine temperatures.

- *Open* the seawater intake seacock *before* starting the engine.
- Keep the seacock *Open* while the engine is running.

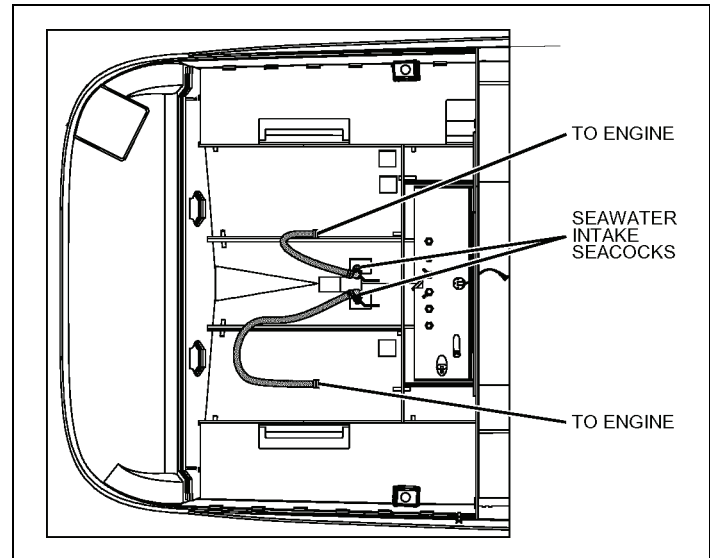

Diesel Engine Cooling System

The diesel engine cooling system circulates seawater through the engine to reduce engine temperatures.

- *Open* the seawater intake ball valve *before* starting the engine.
- Keep the ball valve *Open* while the engine is running.
- Check the cooling system's seawater strainer for leaks and debris *every time* you use your boat.
- Read the seawater strainer instruction sheet for instructions about cleaning the seawater strainer.

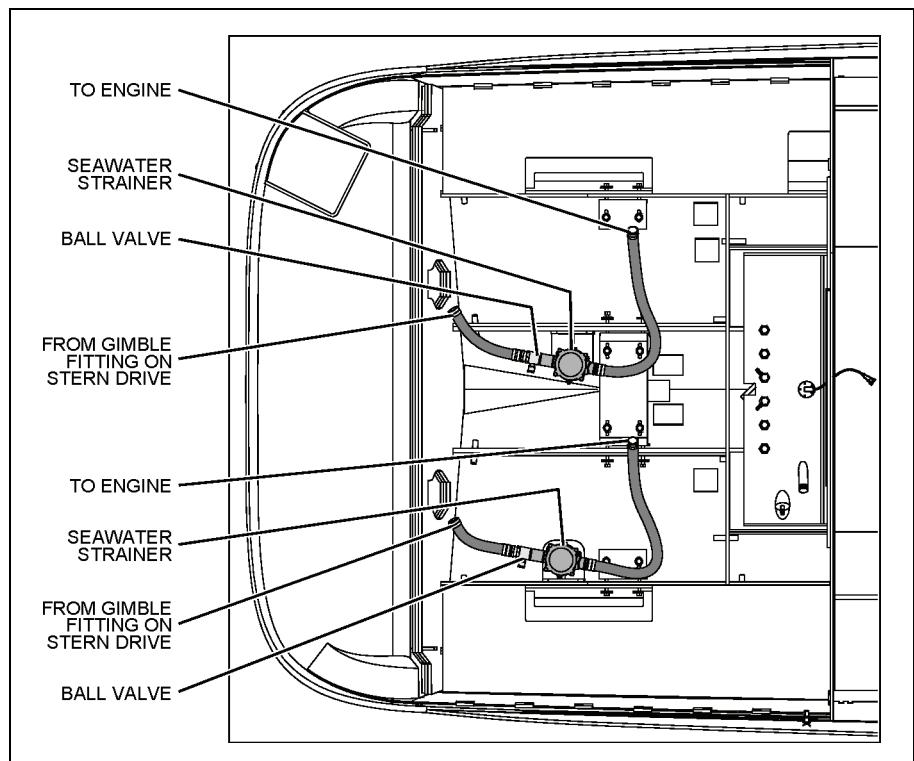

Fuel System

⚠ WARNING!

⚠ FIRE, EXPLOSION, and OPEN FLAME HAZARD!

- It is very important that the fuel system be inspected thoroughly the first time it is filled and at each subsequent filling.
- The fueling instructions in the *Cruiser & Yacht Owner's Manual* and the fuel recommendations in the engine operation manual **MUST** be followed.

⚠ CAUTION

Avoid the storage or handling of gear near the fuel lines, fittings and tank.

NOTICE

- On diesel engine models, air in the diesel supply system can stop an engine or severely restrict performance.
- If you suspect air in the fuel lines, refer to your engine operation manual for detailed instructions on how to bleed the system.

NOTICE

Carefully read the fuel section of both the *Cruiser & Yacht Owner's Manual* and the engine operation manual, paying special attention to the subject of *fuel recommendations*.

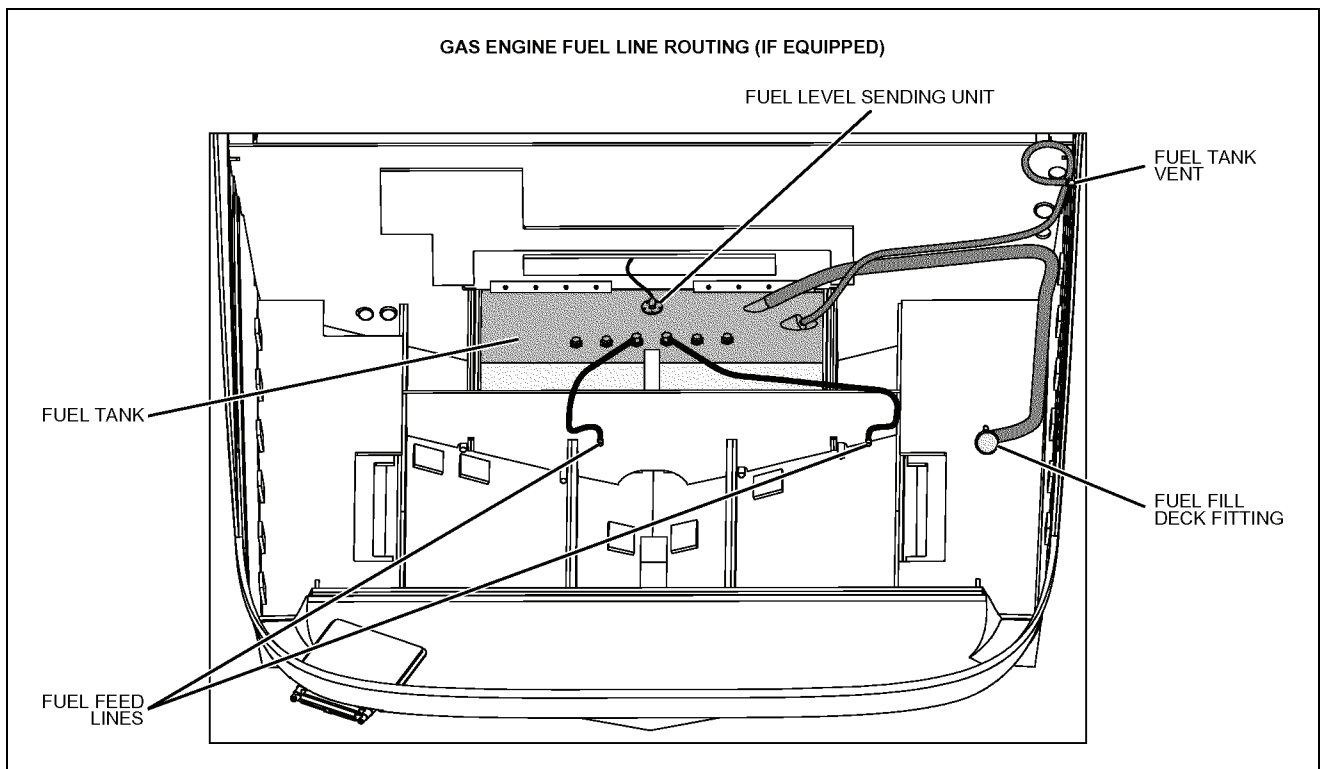

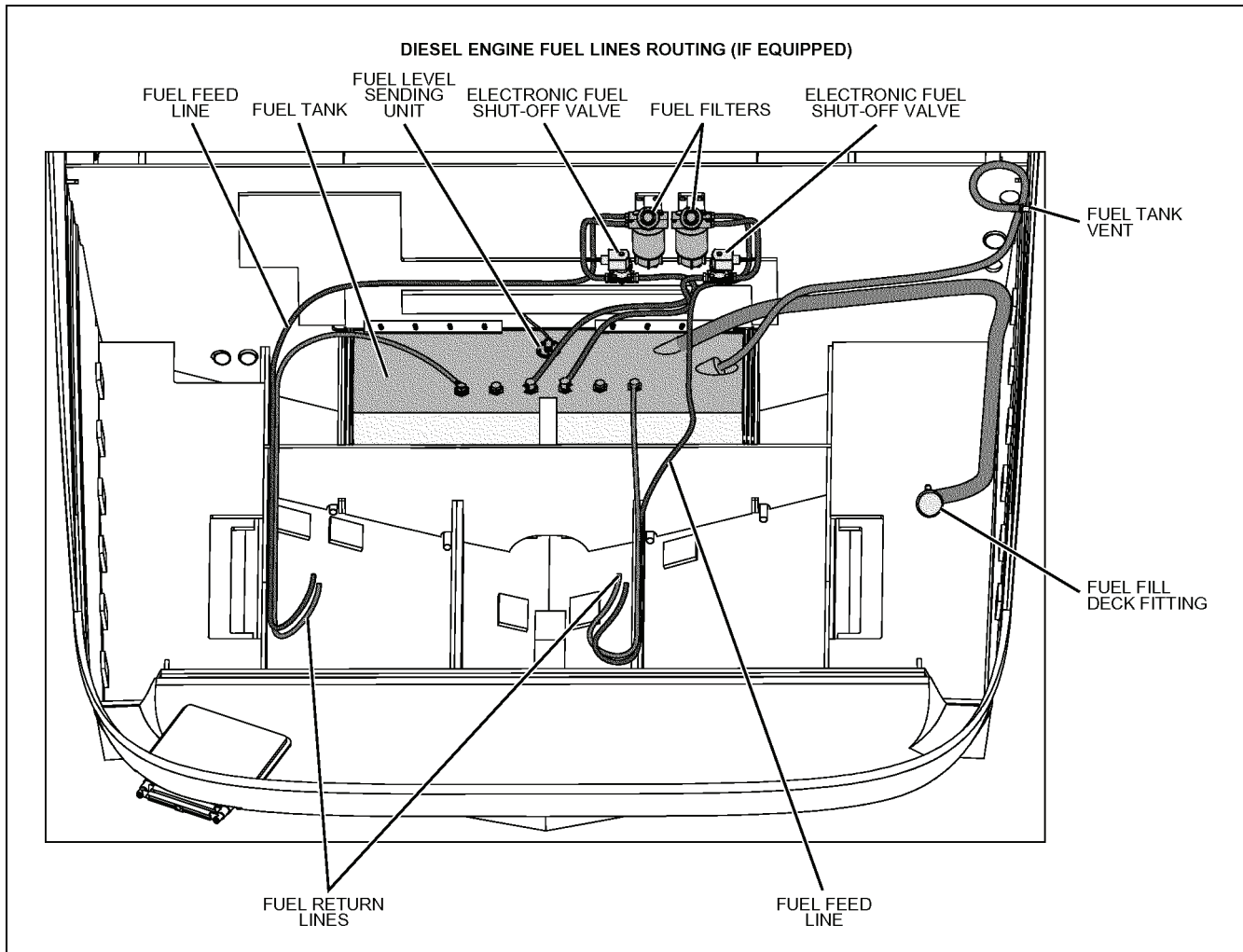

Fuel Fill & Vent

- Depending on engine type, the fuel fill deck fitting is marked either GAS or DIESEL.
- If you have problems filling the fuel tank, see if the fuel fill hose or fuel tank vent hose is kinked or collapsed.
- If there are no visible signs of a problem, contact your local dealer.

Anti-siphon Valves (Gas Engines Only)

NOTICE

- **If an engine running problem is diagnosed as fuel starvation, check the anti-siphon valve.**
- **If the valve is stuck or clogged, *ONLY* change or replace it while the engine is *Off*.**
- ***NEVER* run either engine with its anti-siphon valve removed, except in an emergency.**

- The anti-siphon valves are vital fuel system parts.
- If a fuel line ruptures, this valve prevents the siphoning of fuel from the tank.
- The valves are located on the fuel tank, where the fuel feed lines attach to the tank.
- These valves are spring loaded and are opened by fuel pump vacuum.

Gas Engine Fuel Filters

- The fuel pickup tubes, located inside the fuel tank, are equipped with fine mesh screen filters.
- Also, when supplied by the engine manufacturer, a fuel filter is installed on each engine.
- Periodically replace the fuel filters to make sure they remain clean and free of debris.
- Talk to your selling dealer or local marina about fuel additives that help prevent fungus or other buildup in your fuel tanks.

Diesel Engine Fuel Filter/Water Separators

NOTICE

- The frequency of water draining or element replacement is determined by the contamination level in the fuel.
- Inspect the collection bowls for water daily.
- Replace the elements at least once a year, or when a loss of power is noticed, whichever comes first.

- Each fuel feed line features a fuel filter/water separator.
- Service instructions for the fuel filter/water separators are provided on the filters.

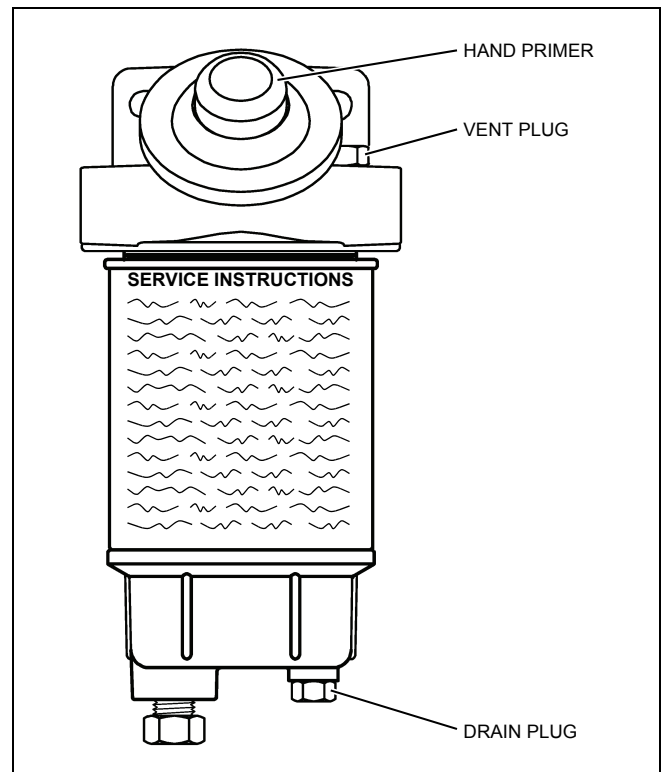

Electronic Fuel Shut-off Valves (Diesel Engines Only)

- Your diesel engines are equipped with electronic fuel shut-off valves.
- When you start your engines, the electronic fuel shut-off valves open to allow fuel to the engines.
- When you turn off the engines, the electronic fuel shut-off valves close, stopping the fuel from going to the engines.
- If one of the electronic fuel shut-off valves malfunctions, it has a manual override.
- Turn the manual override clockwise to open the electronic fuel shut-off valve.

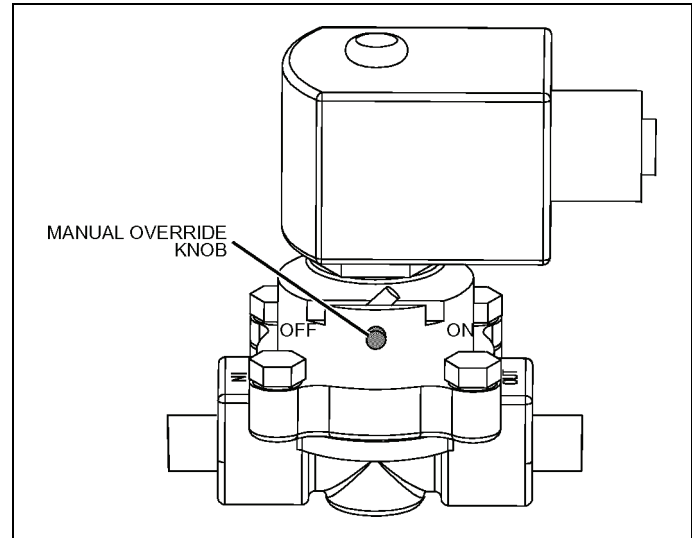

Engine Hatch Lift System (If Equipped)

NOTICE

- Remove any items from the top of the engine hatch **BEFORE** Opening.
- Close all entertainment center doors and hatches **BEFORE** Opening and/or Closing the engine hatch.

- Use the engine hatch rocker switch to open and close the engine hatch.
- At least once a year, check the fluid level in the lift pump's hydraulic fluid reservoir and refill as needed. For the location of the fluid reservoir, see the *Component Locations* section in *Chapter 2* of this supplement.

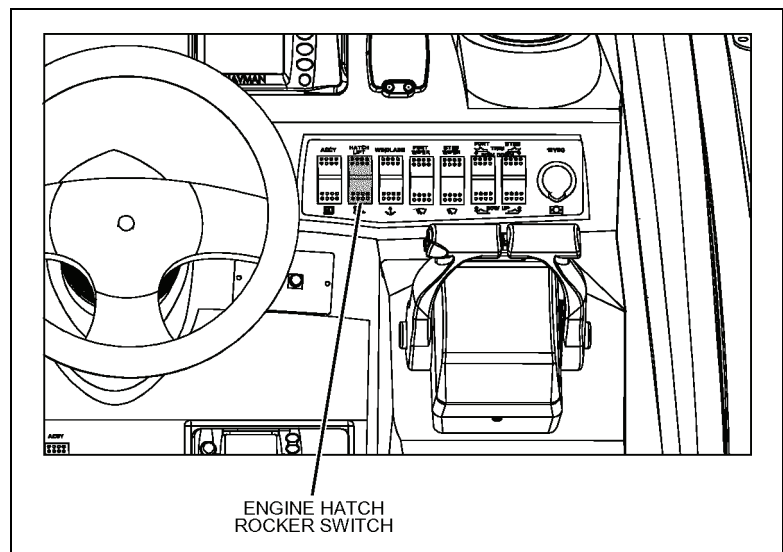

Fire Suppression System (If Equipped)

- The fire suppression system is designed to put out engine room fires.
- **Before** using your boat for the first time, read the fire suppression system's instruction and maintenance manual and follow **all** warnings.
- The system will discharge automatically whenever direct heat from a fire is detected in the engine room.
- The system can be discharged manually by pulling the T-handle (labeled FIRE) at the helm.
- The system can **only** be discharged **once**.
- After the system is discharged it **must** be refilled and refurbished **before** it can be used again.

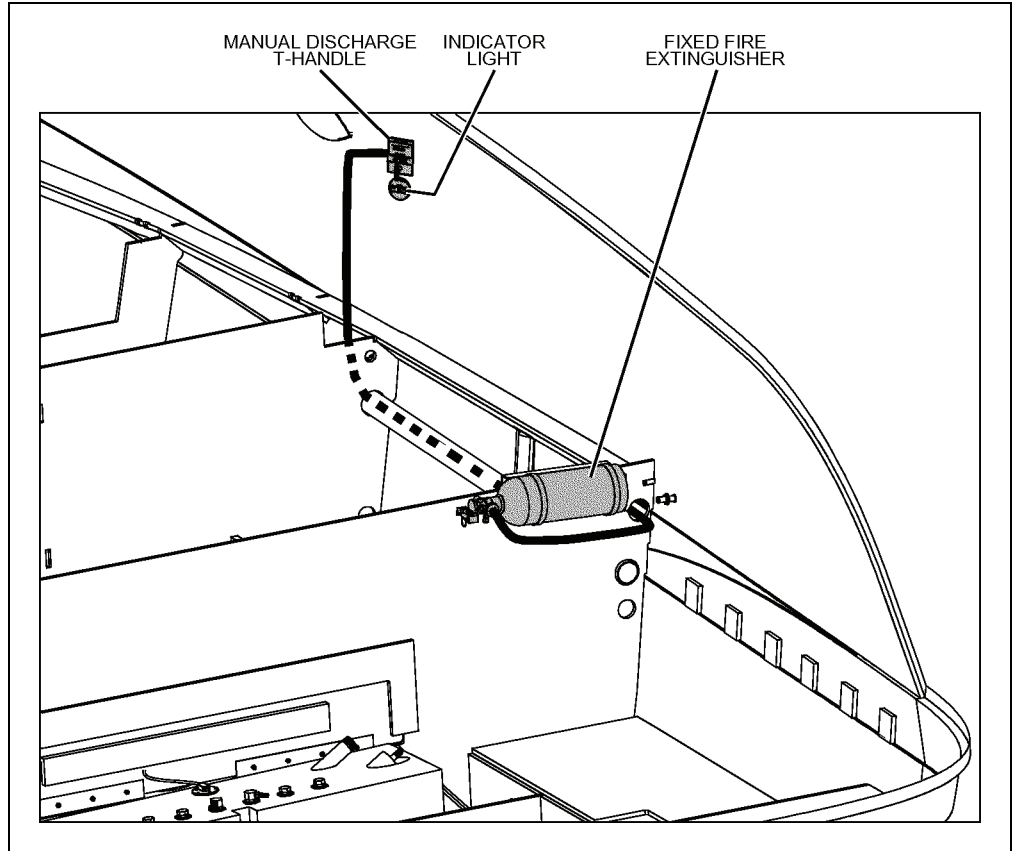

Chapter 4: Controls & Gauges

Steering

- Your boat features a power-assisted rack-and-pinion steering system.
- For information about the power-assist fluid reservoir, refer to the engine operation and maintenance manual.
- Boat steering is *not* self-centering.
- Refer to the engine manual for more steering system details.

Shift/Throttle Controls

 **WARNING!**

LOSS OF CONTROL HAZARD!

Improper maintenance of the shift/throttle hardware may cause a sudden loss of control!

Read *all* of the information about the shift/throttle controls in the shift/throttle manual, the engine operation manual, and the *Cruiser & Yacht Owner's Manual*.

Power Trim & Tilt

- The stern drives on your boat are equipped with power trim and tilt.
- Trim and tilt instructions are provided in the engine operation manual and the shift/throttle manual.

Trim Tabs

- *Before* using the trim tabs, read the trim tabs' owner's manual.
- The trim tabs are controlled by two rocker switches at the helm.
- Check and refill the trim tab hydraulic fluid reservoir as directed in the trim tabs' owner's manual. For the location of the fluid reservoir, see the *Component Locations* section in *Chapter 2* of this supplement.

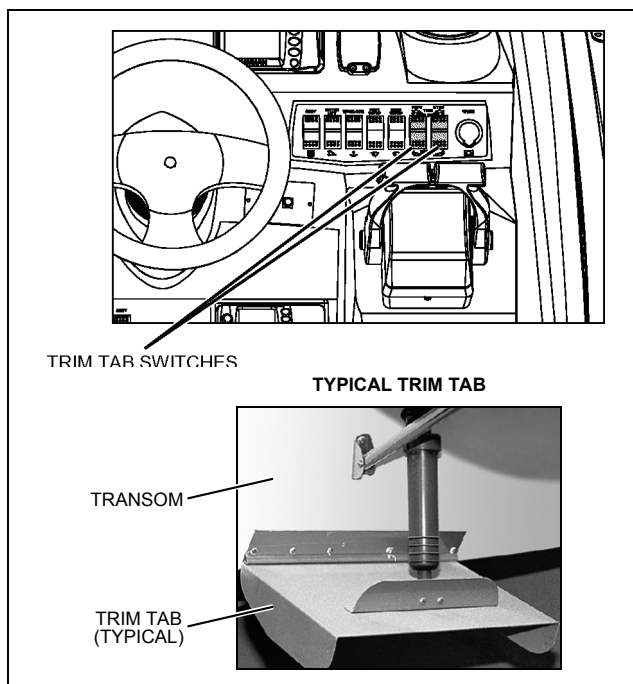

Gauges

Cleaning the Gauges



CAUTION

PRODUCT or PROPERTY DAMAGE HAZARD!

- Use only mild soap and water to clean the gauge lenses and bezels.
- Use of other cleaners, including common window cleaning solutions, may cause the lenses to crack.
- Lenses cracked in this manner will **NOT** be covered by our warranty.

Gauge Fogging

- Moisture may occasionally find its way into the gauges causing lens fogging.
- Turning **On** the gauge lights will help dry the lenses.
- Fogging will not harm the gauges.

Radio Transmission Interference

VHF or other radio transmissions may cause brief erratic readings on the tachometer. This will not damage the tachometer gauge or affect its accuracy when not transmitting.

Fuel Gauge

It is normal for the pointer on your fuel gauge to bounce as fuel sloshes back and forth in the fuel tank.

Twin Engine Readings

It is normal for tachometers and other gauges to have slightly different readings between engines.

Chapter 5: Navigation & Communication Equipment

Read the manuals for *all* navigation & communication equipment *before* using these systems.

Compass

NOTICE

- **Compass accuracy can be affected by many factors.**
- **Have a trained technician calibrate your compass.**
- **Make sure the technician gives you a deviation card which shows the corrections to apply in navigational calculations.**
- **Keep a copy of the deviation card at the helm.**

Depth Finder (If Equipped)



WARNING!

- **Do *NOT* use the depth finder as a navigational aid to prevent collision, grounding, boat damage or personal injury.**
- **When your boat is moving, submerged objects will *NOT* be seen until they are already under your boat.**
- **Bottom depths may change too quickly to allow time for your boat to react.**
- **If you suspect shallow water or submerged objects, run your boat at very slow speeds.**

VHF Radio (If Equipped)

- Your boat may include a VHF (Very High Frequency) radio.
- As permitted by the FCC (Federal Communications Commission), the VHF radio can be used to access weather reports, summon assistance, or contact other vessels.
- Contact the FCC for licensing, rules and laws concerning VHF radio usage.

Global Positioning System (GPS) (If Equipped)



WARNING!

- The GPS system should **NOT** be relied upon as the **ONLY** aid to navigation.
- An experienced operator **MUST** monitor the GPS system at **ALL** times and keep a look-out for other marine traffic and possible collision situations.

NOTICE

The GPS system is **ONLY** an aid to navigation. It's accuracy can be affected by:

- **Equipment failure or defects**
- **Environmental conditions**
- **Improper handling or use**

Chapter 6: Plumbing

Bilge Pumps

NOTICE

Discharge of oil, oil waste, or fuel into navigable waters is prohibited by law. Violators are subject to legal action by the local authorities.

- Your boat has two bilge pumps for pumping water out of the bilge.
- The autofloat switches, mounted next to the bilge pumps, will turn **On** the bilge pumps if bilge water rises above a preset level.
- You can also turn **On** the bilge pumps using the switches at the helm.
- The bilge pumps are wired directly to the batteries. Unless the batteries are dead, the bilge pump system should work even when your boat is unattended.

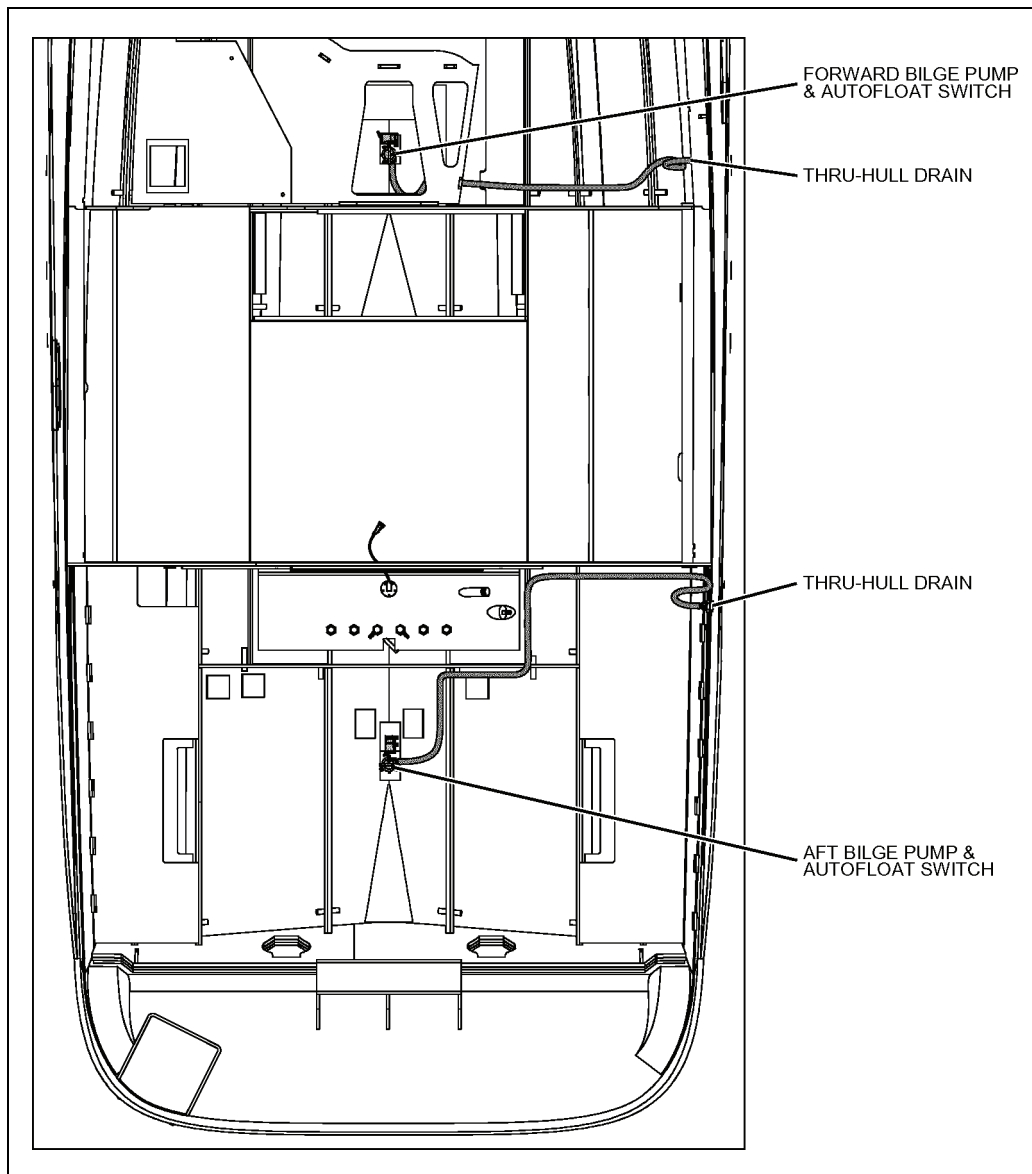

Bilge Pump Testing

- The bilge pumps are vital to the safety of your boat.
- Test the bilge pumps often by performing the following steps:
 1. One at a time, turn **On** each bilge pump switch at the helm.
 2. Make sure that water in the bilge is pumped overboard.
- If there is water in the bilge and the pump motor is running but **not** pumping, inspect the discharge hose for a kink or collapsed area.
- If the discharge hose looks okay, perform the following steps to check the bilge pump and strainer for clogging debris:

Inspecting and clearing debris from the bilge pump:

1. Squeeze the holding tabs on each side of the strainer and pull the pump housing out of the strainer.
2. Remove debris from the strainer and the bottom of the pump housing.
3. Remove the impeller guard screw and the impeller guard.
4. Remove all debris from the pump chamber, from around the impeller, and from the tab slots on the sides.
5. Make sure the impeller is firmly attached to the shaft and is not cracked or broken.
6. Reinstall the impeller guard and screw.
7. Reinstall the pump housing on the strainer, making sure both tabs lock into the slots.

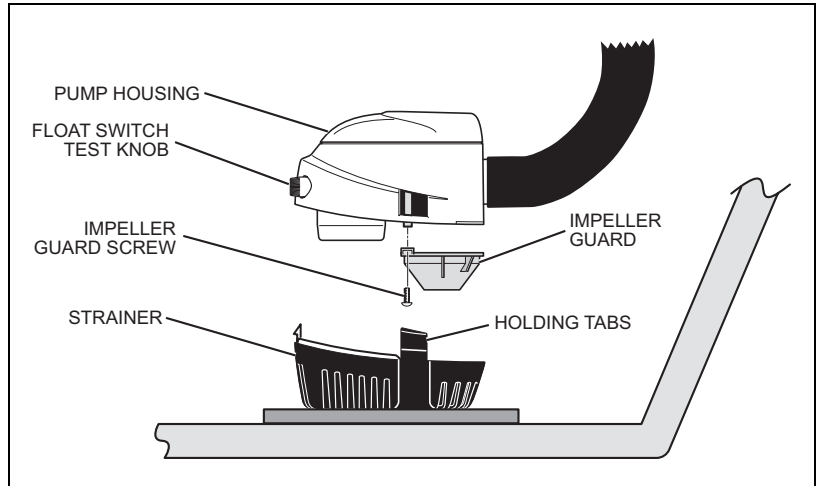

Built-in Autofloat Switch Testing

The autofloat switch turns the bilge pump **On** when water rises above a preset level. Test the autofloat switch often as follows:

- Twist the float switch test button to turn **On** the bilge pump.
- If the pump does not turn **On**, check the fuse on the fuse block.
- If the fuse is good, but the switch still does not work, it may mean the switch is bad, or the battery is dead.

Seawater Systems

Seacocks

WARNING!

FLOODING and SWAMPING HAZARD!

- *Close* the seacock(s) when leaving your boat unattended for any length of time.
- If a seacock is left open, a hose failure could flood the bilge, swamp the batteries and the engines, and even sink your boat.

CAUTION

SYSTEM DAMAGE HAZARD!

- **BEFORE** using any system that has a seacock, make sure that the system's seacock is *Open*.
- Inspect and lubricate all seacocks annually.

Thru-hull inlet or outlet fittings near or below the waterline feature seacock valves. You can close a seacock to stop water entry:

- If the hose connected to the seacock fails, or;
- To work on equipment served by the seacock.

Seacocks are used on your boat in seawater intake or liquid-discharge systems including, but not limited to:

- Generator (if equipped)
- Air conditioner (if equipped)
- Marine head (toilet)

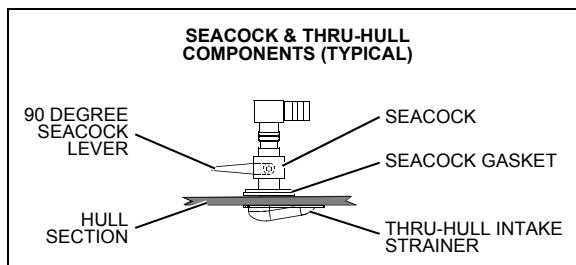

Before using any system with a seacock, make sure the seacock is *Open* and stays *Open* until the system is shut *Off*.

Seawater Strainers

CAUTION

FLOODING HAZARD!

- **BEFORE** taking apart a seawater strainer for cleaning or other work, *Close* the seacock that sends seawater to that strainer.
- Failure to close the seacock before taking apart the seawater strainer may allow large amounts of water to flood the bilge, which could swamp the batteries and the engines, and even sink your boat.
- Keep the seacock *Closed* until the seawater strainer is completely reassembled.

SYSTEM DAMAGE HAZARD!

- **After** putting the seawater strainer back together, make sure that the seacock valve is *Open* **BEFORE** using the component/system.

- Seawater strainers are used to filter incoming seawater in *some* seawater intake systems. NOTE: Not all seawater intake systems have seawater strainers.
- If equipped, the seawater strainer is located near the seawater intake system's seacock.
- Check the strainers for leaks and/or debris **every time** you use your boat.
- Refer to the seawater strainer instruction sheet for cleaning and maintenance information.

Freshwater System



WARNING!

- **ONLY** use safe drinking (potable) water in your boat's freshwater system.
- **ONLY** use FDA approved "drinking water safe" hoses when filling the freshwater tank.
- **NEVER** use common garden hoses for drinking water.

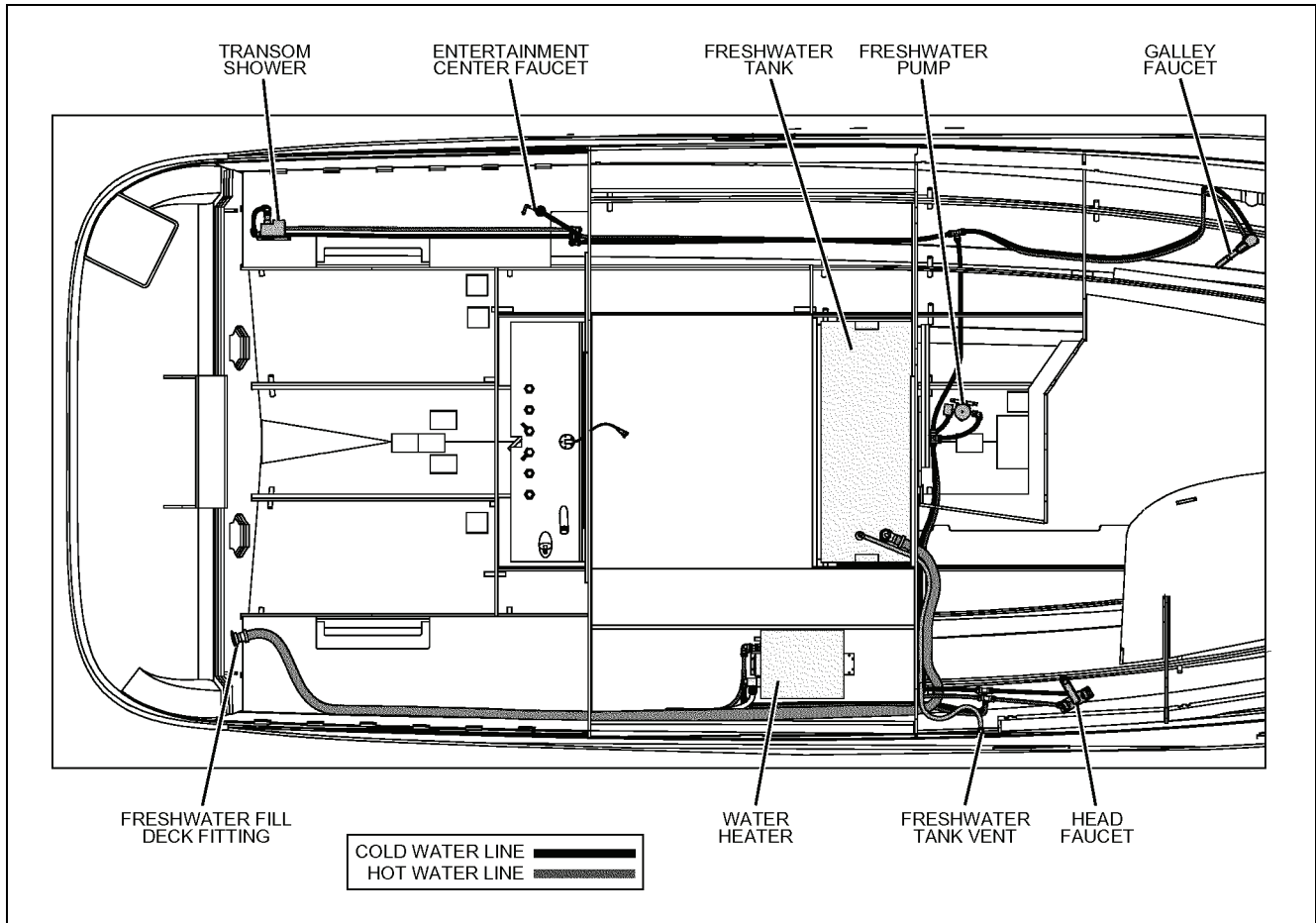

- Read the *Freshwater System* section in the *Cruiser & Yacht Owner's Manual*.
- The freshwater fill deck fitting is marked **WATER**.
- Pressurize the freshwater system by turning **On** the freshwater pump switch (the battery switch must also be **On**).
- For the location of the freshwater pump switch, see the *Component Locations* section in *Chapter 2* of this *supplement*.
- Turn **Off** the freshwater pump switch when your boat is **not** in use or when the freshwater tank is empty.
- Inspect and clean the freshwater filter often (the filter is located on the freshwater pump).
- If your boat is to be left unattended for a long period of time, pump the freshwater tank dry to prevent stored water from becoming stagnant and distasteful.
- If the freshwater system needs to be disinfected, ask your dealer about treatments available for your boat's system.

Transom Shower (If Equipped)

- Read the manufacturer's instructions *before* using the transom shower for the first time.
- The freshwater pump switch *must* be turned **On before** using the transom shower.

Freshwater System Winterization

1. Turn **Off** the water heater breaker switch.
NOTE: *Tag* or *Mark* the water heater breaker switch to prevent it from being turned **On** while the water heater tank is empty.
2. Turn **On** the freshwater pump switch.
3. **Open all** of the faucets and showers and let the freshwater system drain completely.
4. Turn **Off** the freshwater pump switch.

All of the remaining water *must* be removed from the water lines. There are two ways to remove the remaining water from the lines:

- Compressed Air
- Gravity Draining

Compressed Air

CAUTION

FRESHWATER SYSTEM DAMAGE HAZARD!

- A faucet **MUST** be *Open* when compressed air is blown through the freshwater system.
- **NEVER** blow compressed air through the water system when **ALL** of the faucets are *Closed*.

You *must* have an air compressor with an air hose and an air nozzle.

1. Remove the water line from the outlet side of the freshwater pump (opposite side from filter).
2. **Open** the faucet that is furthest away from the freshwater pump.
3. Place the air nozzle against the end of the just removed water line and blow air through the system.
4. When water stops coming out of the faucet, stop the air and **Close** the faucet.
5. One at a time, repeat this process on **all** faucets and showers.

Gravity Draining

1. **Open all** faucets and showers.
2. Remove the drain plug from the tee fitting on the freshwater tank.
3. When the water has stopped draining from the freshwater tank and the water lines, replace the drain plug.

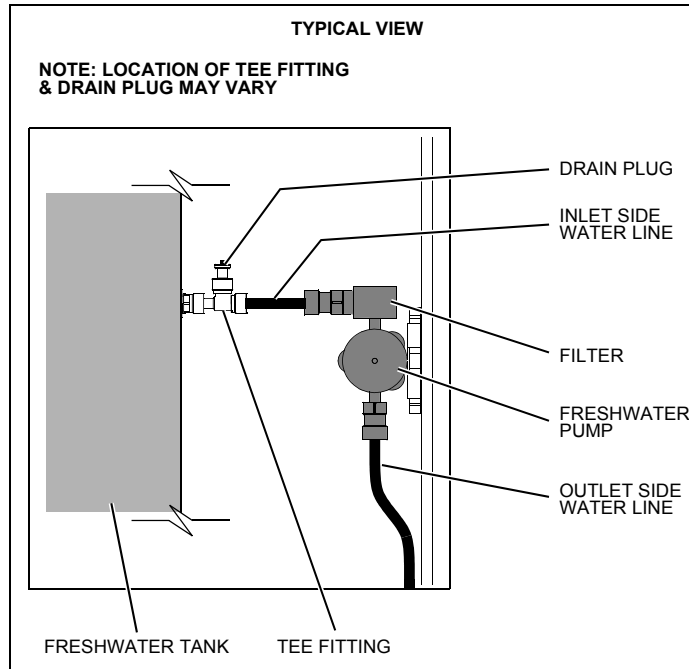

Water Heater

 WARNING!	
	SCALDING HAZARD! Water heated by the water heater can be hot enough to scald the skin.

 CAUTION	
WATER HEATER DAMAGE HAZARD!	
<ul style="list-style-type: none"> • Do NOT turn On the water heater circuit breaker on the 110-volt AC master panel until the water heater tank is COMPLETELY filled with water. • The tank is full if water flows from the tap when the hot water is turned On in the galley. • Even brief water heater operation with a dry tank WILL damage the heating elements. • Warranty replacements will NOT be made on elements damaged in this manner. • Turn the power Off and drain the water heater when the chance of freezing exists (see the winterizing instructions below). 	

NOTICE	
If 110-volt AC power is being provided by shore power or generator power, but the water heater is not working:	
<ul style="list-style-type: none"> • Make sure the water heater circuit breaker on the 110-volt AC master panel is switched On. • If the circuit breaker is On, but the water heater is still not working, ask your dealer how to check the push-to-reset circuit breaker located on the water heater. 	

- Read the water heater instruction manual and heed the warnings above.
- The water heater is connected to the 110-volt AC power system.
- To heat the water, turn **On** the water heater circuit breaker on the 110-volt AC master panel.

Winterizing the Water Heater



CAUTION

WATER HEATER DAMAGE HAZARD!

- **NEVER** turn *On* the water heater breaker on the 110-volt AC master panel while the water heater tank is empty.
- Even brief water heater operation with a dry tank **WILL** damage the heating elements.
- Warranty replacements will **NOT** be made on elements damaged in this manner.
- To prevent damage to the water heater after winterizing, always label the breaker switch on the 110-volt AC master panel as 'winterized'.

NOTICE

The freshwater system **MUST** be drained **BEFORE** winterizing the water heater (see the *Freshwater System Winterization Instructions* on the previous page).

1. Turn **Off** the water heater breaker.
 2. Disconnect the hose (A) attached to the pressure relief valve (B), and drain any water from the hose into the bilge or into a bucket.
 3. **Open** the pressure relief valve (B).
 4. **Open** the drain valve (C).
 5. Attach a tag to the water heater breaker to indicate that the tank is empty.
- NOTE: Your boat came with a tag attached to the water heater breaker. It is suggested that you keep this tag and re-use it when winterizing.
 - Leave the pressure relief and drain valves **Open** until you fit out your boat after storage.

NOTE:
TYPICAL WATER
HEATER SHOWN.
LOCATIONS OF
FITTINGS MAY
VARY BY BRAND
AND MODEL.

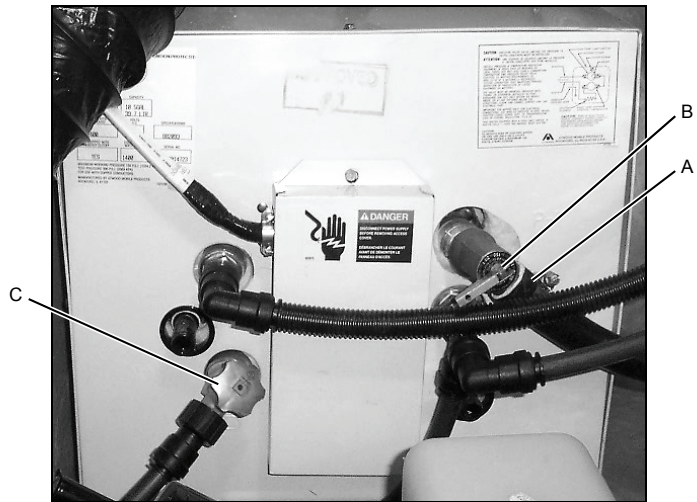

TYPICAL 110-VOLT AC MASTER PANEL

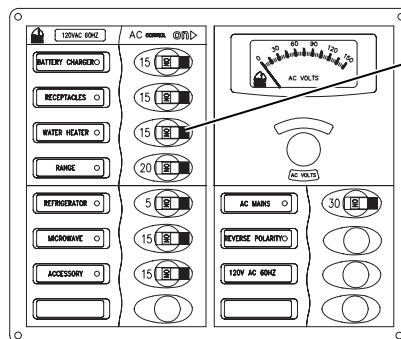

WATER HEATER
BREAKER

WATER HEATER
BREAKER TAG

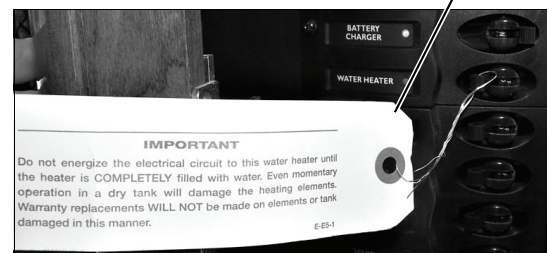

Preparing the Water Heater for Use After Boat Storage



CAUTION

WATER HEATER DAMAGE HAZARD!

- Fill the water heater tank *BEFORE* turning *On* the water heater breaker on the 110-volt AC master panel.
- *NEVER* turn *On* the water heater breaker on the 110-volt AC master panel while the water heater tank is empty.
- To test if the tank is full, turn *On* a hot water faucet. If water flows from the tap, the water heater tank is full.
- Even brief water heater operation with a dry tank *WILL* damage the heating elements.
- Warranty replacements will *NOT* be made on elements damaged in this manner.

When you are ready to resume use of your boat after it has been in storage, prepare the water heater for use as follows:

1. **Close** the drain valve (C).
2. **Close** the pressure relief valve (B).
3. Connect the hose (A) to the pressure relief valve (B).
4. Fill the water heater tank with freshwater.
5. Remove the 'winterized' tag on the water heater breaker on the 110-volt AC master panel **after** the water heater tank is **completely** filled with freshwater.
6. Turn **On** the water heater breaker.

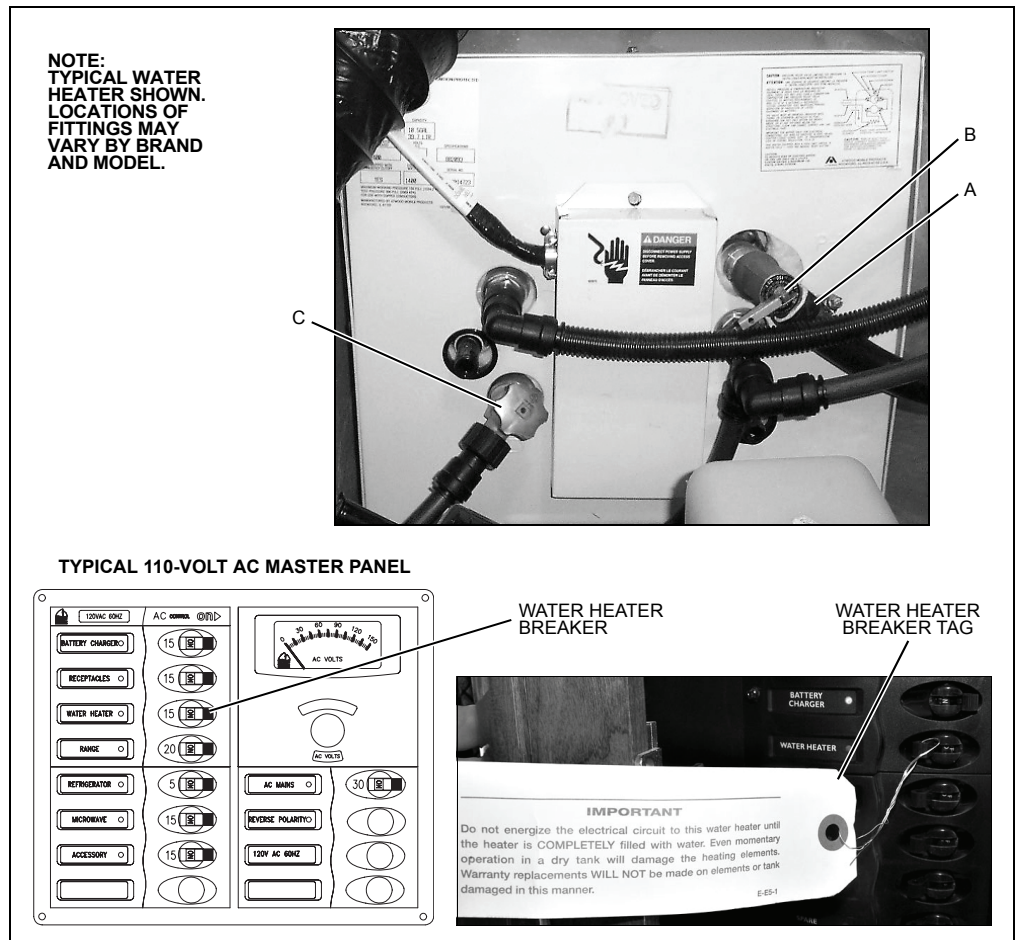

Drain Systems

Deck Drains

- Water on the deck is drained overboard through the deck drains.
- Keep the deck drains free of debris.

Galley Sink Drain

The galley sink is above the waterline and is gravity drained overboard.

Sump Pump System

- The sink and the shower in the head drain into the sump pump box.
- The air conditioner pan (if equipped) also drains into the sump pump box.
- An autofloat switch turns **On** the sump pump when the drain water rises to a preset level, and the drain water is pumped overboard.
- Read the sump system instruction sheet, paying special attention to the maintenance and cold weather instructions.

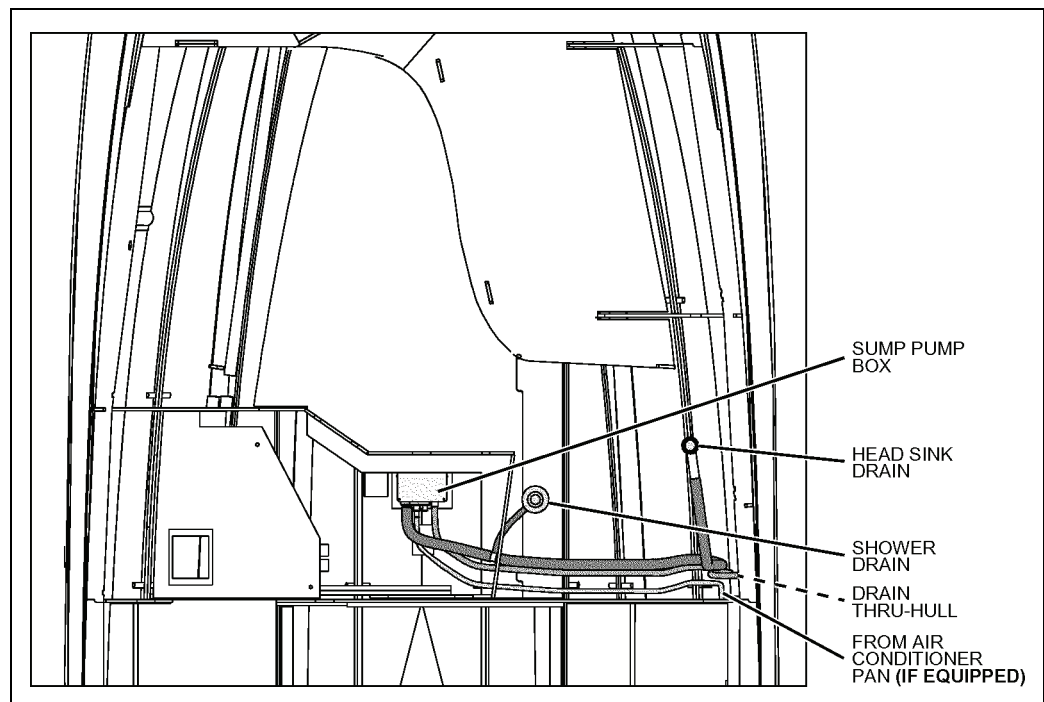

Marine Head & Holding Tank

NOTICE

Check with local authorities about the legal use of marine head systems.

Manual Flush Head (If Equipped)



WARNING!

FLOODING and SWAMPING HAZARD!

- *Close* the seawater intake seacock when leaving your boat unattended for any length of time.
- If the seacock is left open, a hose failure could flood the bilge, swamp the batteries and the engines, and even sink your boat.

- *Before* using this system, read the marine head's operation and maintenance manual.
- Look at the side of the holding tank to check the content level.
- The dockside pump-out deck fitting is marked WASTE.
- Empty the holding tank at every opportunity.

Using the Marine Head

1. *Open* the head's seawater intake seacock.
 2. *Before* using the head, pump water into the bowl to wet the sides.
 3. After use, pump until the bowl is clean.
 4. Pump a few more times to clean the lines.
 5. If excess waste causes the water to rise in the bowl, stop pumping until the water recedes.
- *Close* the intake seacock when the system will not be used for long periods of time.

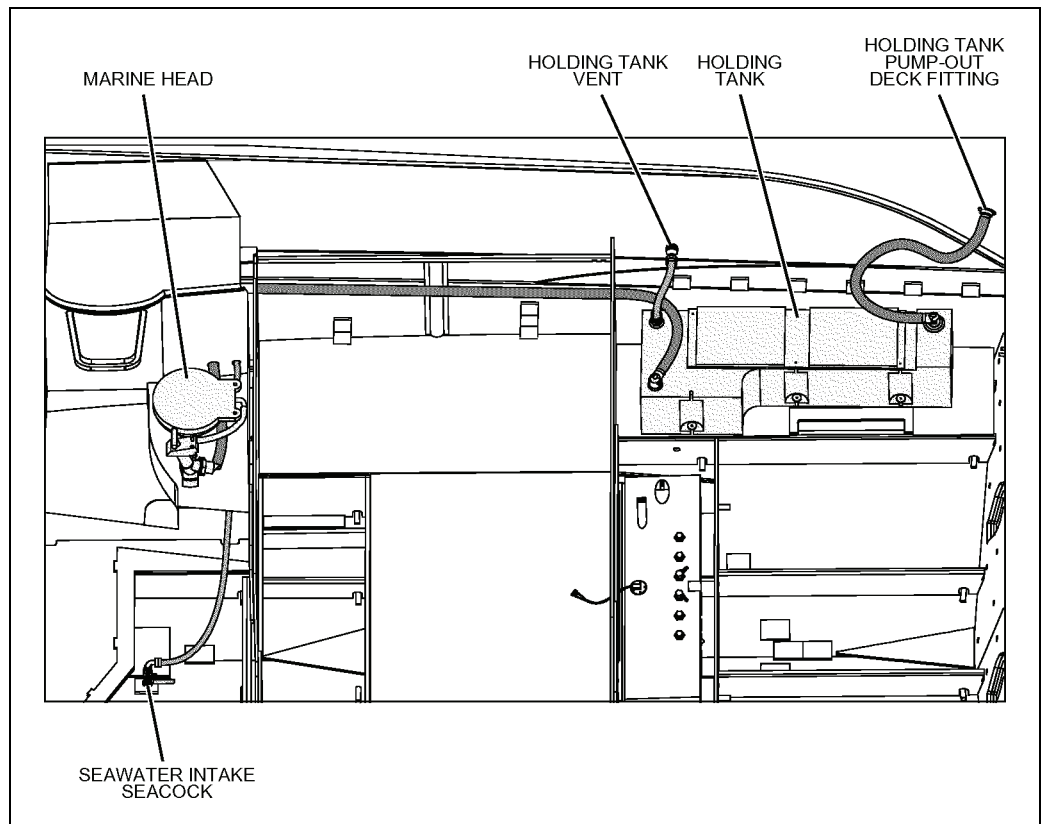

Winterizing the System

Read the marine head's operation and maintenance manual for winterizing instructions.

Electric Flush Head (If Equipped)

⚠ WARNING!

FLOODING and SWAMPING HAZARD!

- **Close** the seawater intake seacock when leaving your boat unattended for any length of time.
- **If the seacock is left open, a hose failure could flood the bilge, swamp the batteries and the engines, and even sink your boat.**

- Read the marine head operation and maintenance manual *before* using the marine head for the first time.
- The electric flush marine head uses seawater to flush waste from the toilet into the holding tank.
- The seawater intake valve (seacock) *must* be **Open** for the head to work.
- Check the content level of the holding tank often by looking at the side of tank.
- Empty the holding tank at every opportunity.
- The holding tank is plumbed to a fitting on the deck for dockside pump-out.
- Keep the intake seacock **Closed** while your boat is underway or when the system will not be used for long periods of time.

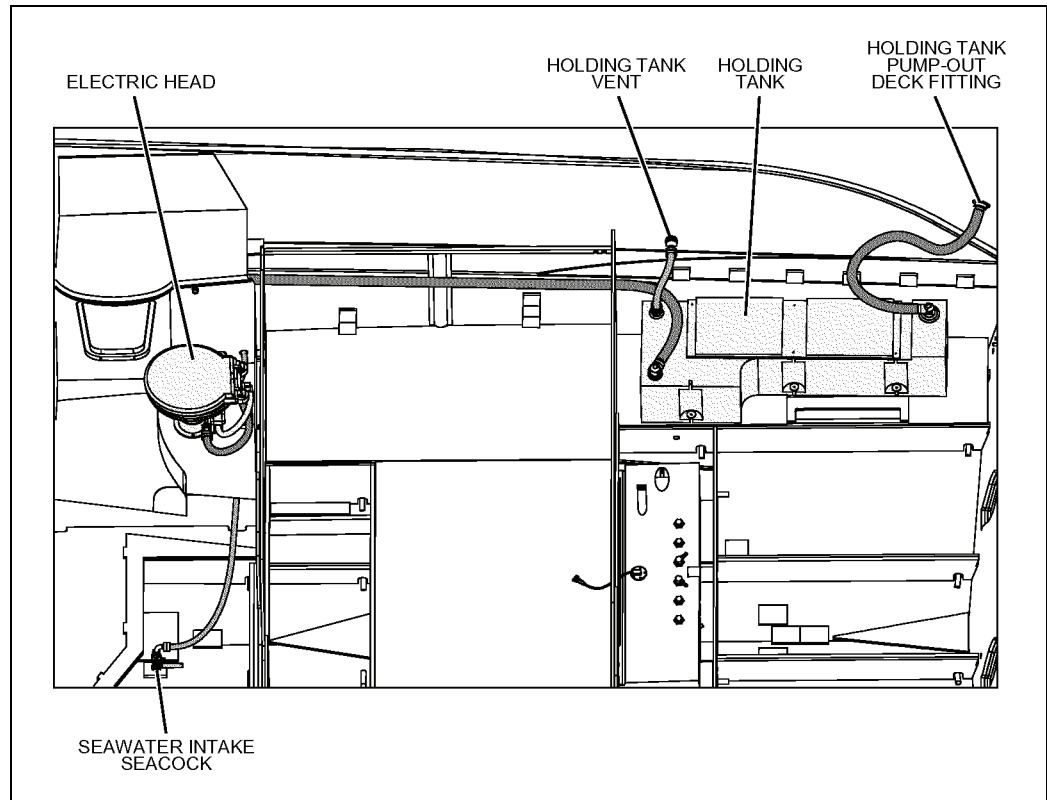

Winterizing the System

Read the marine head operation and maintenance manual for winterizing instructions.

Macerator (If Equipped)

To use the macerator to pump waste directly overboard (where laws permit):

1. **Open** the underwater discharge seacock.
2. Press both macerator switches at the same time to run the pump.
3. Stop running the macerator as soon as the holding tank is empty.
4. **Close** the underwater discharge seacock when you are done pumping.

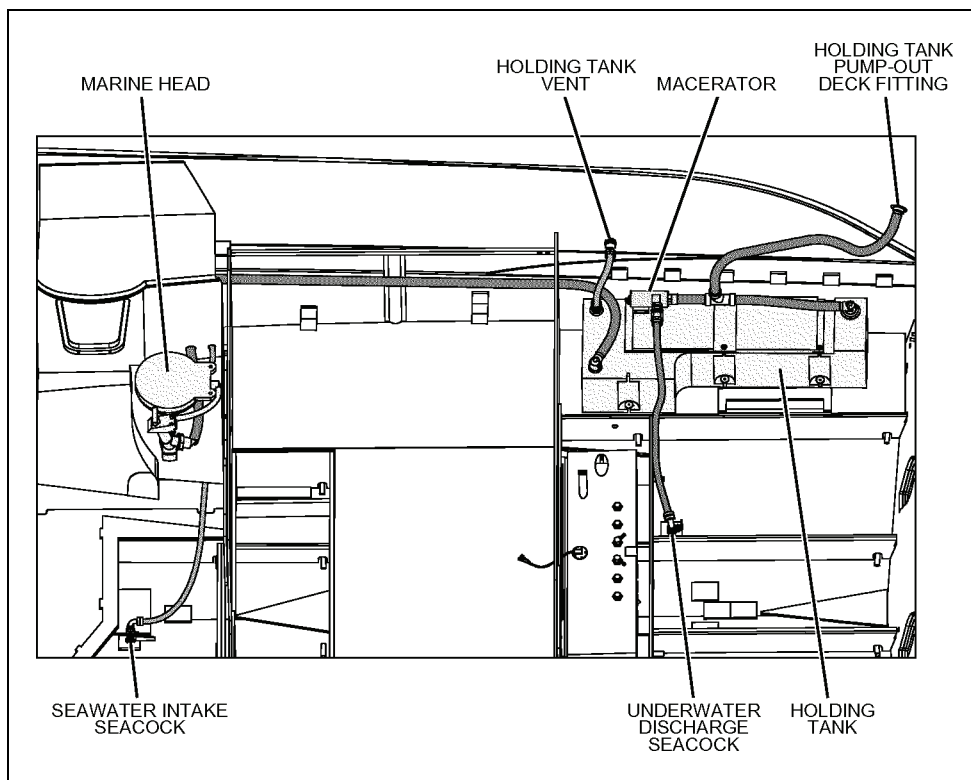

Air Conditioner (If Equipped)

⚠ **DANGER!**

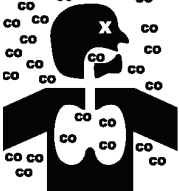

CARBON MONOXIDE POISONING HAZARD!

- Dangerous carbon monoxide gas (CO) can be brought into your boat through the air conditioning system.
- Read the *Carbon Monoxide (CO)* section in *Chapter 1* of this supplement.

⚠ **CAUTION**

SYSTEM DAMAGE HAZARD!

The air conditioning system's seawater intake seacock *MUST* be *Opened BEFORE* turning *On* the air conditioner and *MUST* stay *Open* during use.

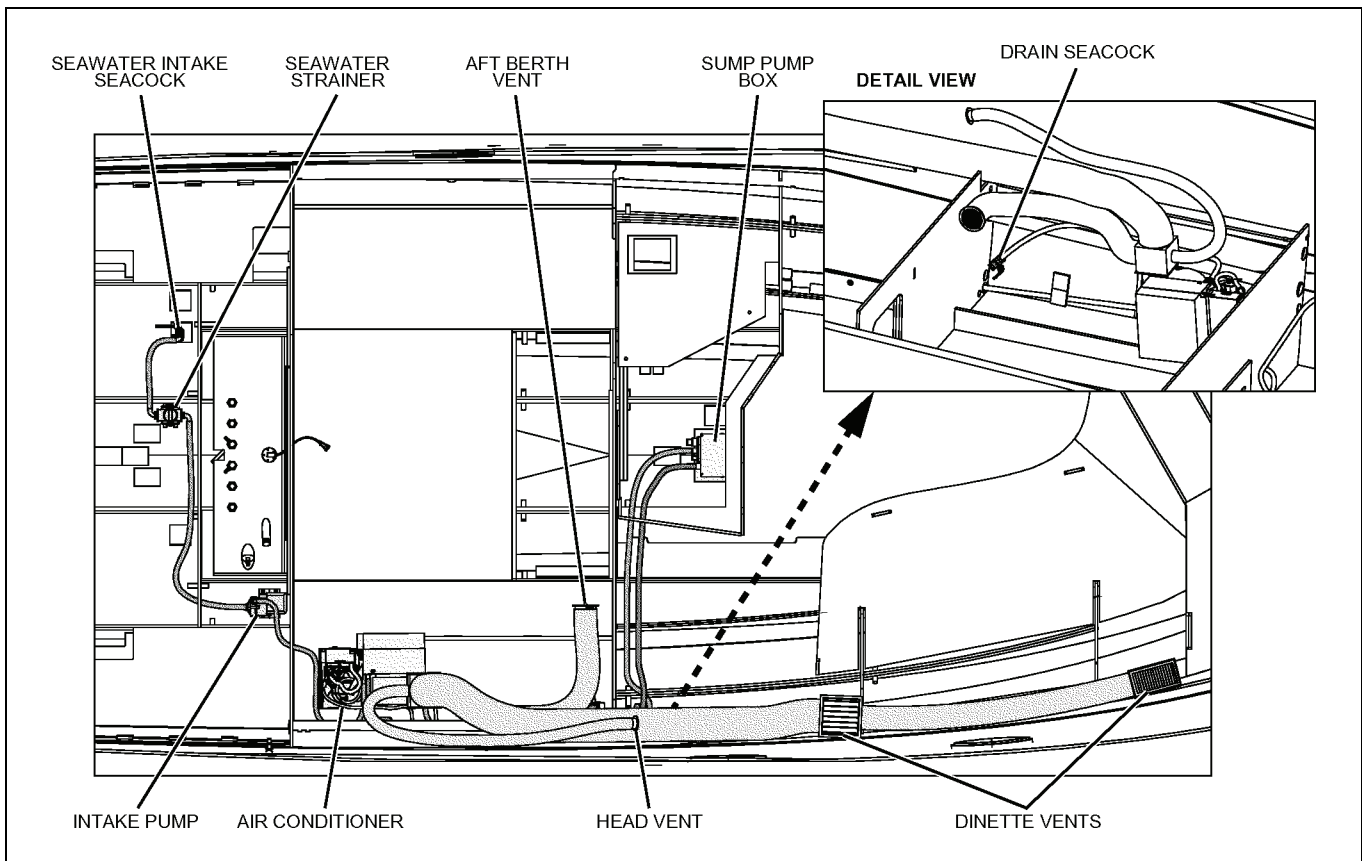

- Read the air conditioner manual *before* using the air conditioning system.
- *Before* using the air conditioning system, make sure the breakers on the 110-volt AC master panel are turned *On* and that the system's seawater intake and drain seacocks are *Open*.
- The seacocks *must* remain *Open* while the air conditioner is in use.
- Check the seawater strainer for debris *before* each use of the air conditioning system. If the strainer needs to be cleaned out, follow the directions in the *Seawater Systems* section earlier in this chapter.

Chapter 7: Deck Equipment

Cleats & Bow/Stern Eyes

 WARNING!
PERSONAL INJURY and/or PRODUCT or PROPERTY DAMAGE HAZARD!
NEVER lift your boat using the bow/stern eyes or the cleats.

Read the section on towing in the *Cruiser & Yacht Owner's Manual* **before**:

- Towing anything behind your boat.
- Being towed by another vessel.

Windlass (If Equipped)

 DANGER!
PERSONAL SAFETY & PRODUCT DAMAGE HAZARD!
An unsecured anchor could accidentally release while your boat is moving, damaging your boat and causing serious injury or death.
After retrieving the anchor:
<ul style="list-style-type: none">• Secure the anchor with an anchor safety strap, or a chain stopper.• Switch OFF the windlass circuit breaker to prevent accidental operation.

 CAUTION
PRODUCT DAMAGE HAZARD!
Do NOT rely on the windlass alone to hold your boat at anchor. After setting the anchor, tie the rode off to a cleat or equivalent strong point.
Do NOT pull your boat to the anchor using the windlass, or continue running the windlass if it has stalled or is overloaded.

- Read and follow the manufacturer's instruction manual **before** using the anchor windlass for the first time.
- The windlass can be controlled from a switch at the helm or from the deck foot switches.
- Make sure that the windlass circuit breaker is turned **On before** using the anchor windlass.
- To raise the anchor, use engine power (**not** the windlass) to move your boat to, and directly above, the anchor.
- Dislodge the anchor from the bottom by pulling it straight up with the windlass.
- **Before** getting underway, make sure the anchor is secured and the windlass circuit breaker is turned **Off**.

Canvas

Canvas & Vinyl Tops & Enclosures



CAUTION

PRODUCT or PROPERTY DAMAGE HAZARD!

Take down and securely stow *ALL* canvas & vinyl *BEFORE* your boat is transported by road.

NOTICE

BEFORE cleaning and/or stowing your canvas or vinyl, read the sections later in this chapter, *Canvas Care* and *Clear Vinyl Care*.

NOTICE

Two people are needed for most of the tasks listed in this section.

NOTICE

Some canvas and vinyl options may not be described. Make sure your dealer explains how to install all canvas and vinyl.

Bimini Top (If Equipped)

1. Insert the end eyes of the main bow (A) into the aft windshield hinges and secure them with the pins.
 2. Snap the aft edge of the canvas to the radar arch.
 3. Insert the end eyes of the braces (B) into the forward windshield hinges and secure them with the pins.
- The jaw slides should not need to be adjusted.
 - If you decide to adjust the jaw slide positions, get the correct measurements from your selling dealer.

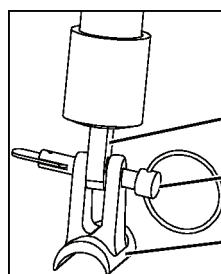
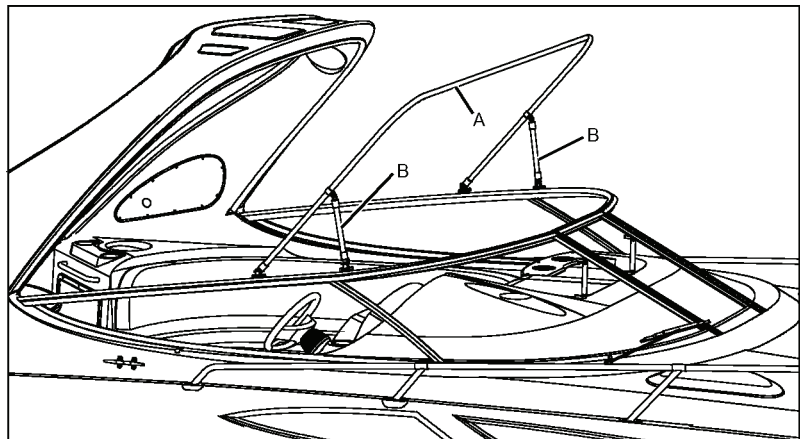

END EYE
SECURING PIN
WINDSHIELD HINGE

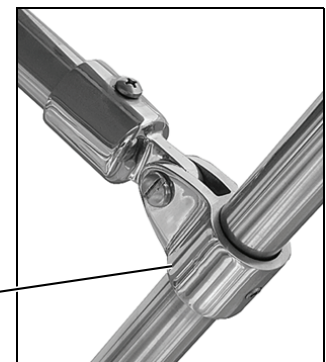

JAW SLIDE

Aft Bimini Top

1. Insert the end eyes of the main bow (A) into the hinges on the radar arch and secure them with the pins.
 2. Pull the secondary bows (B) forward and snap the forward edge canvas snaps to the radar arch.
 3. Insert the end eyes of the braces (C) into the deck hinges and secure them with the pins.
- The jaw slides should not need to be adjusted.
 - If you decide to adjust the jaw slide positions, get the correct measurements from your selling dealer.

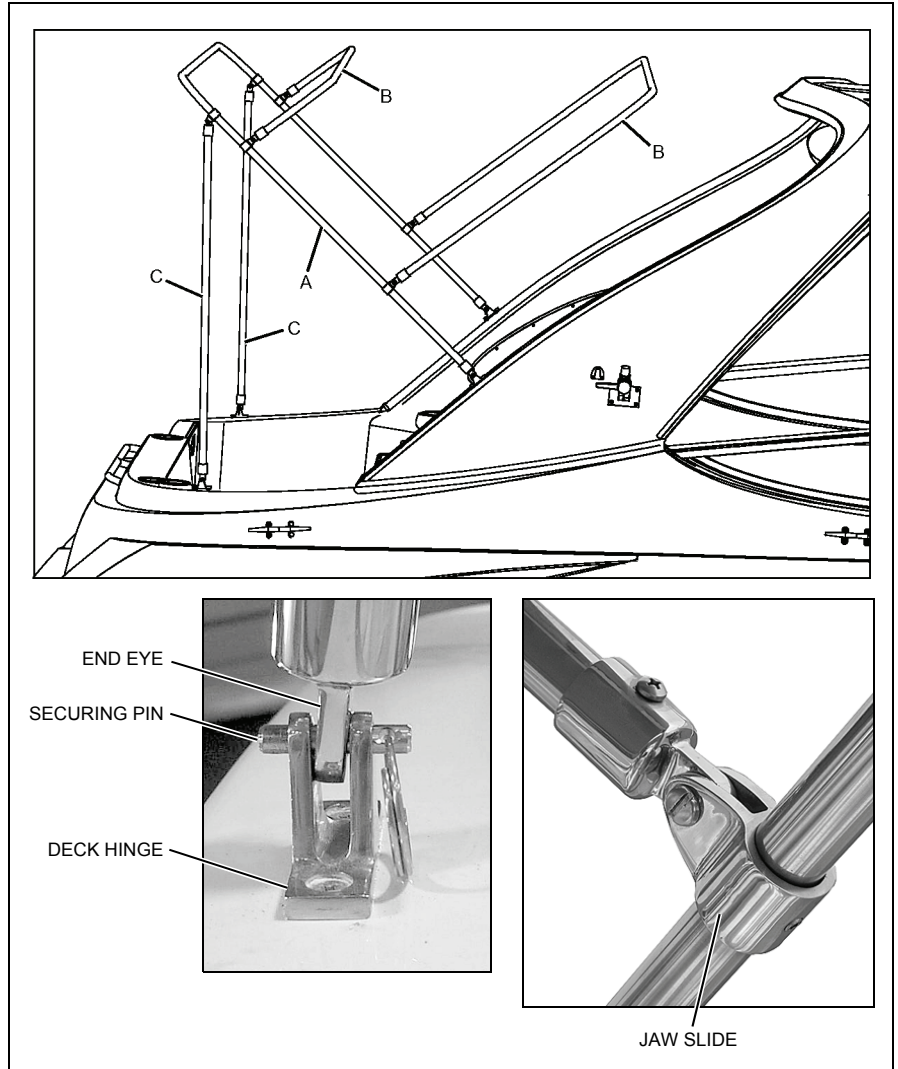

Vinyl Curtains (If Equipped)

Make sure your dealer explains how to install the vinyl.

Canvas Care (see also 'Clear Vinyl Care' on next page)

- After each use, especially in saltwater, rinse the canvas with cold freshwater.
- **Before** stowing, let the canvas air-dry completely.
- The canvas can be rolled or folded for stowage.

Cleaning the Canvas

 CAUTION
<p>NEVER use detergents when washing the canvas. Detergents can destroy the water repellency, and mildew/UV resistant finish of your canvas.</p>

Regularly clean the canvas to prevent dirt, pollen, and etc. from embedding in the fabric. Generally, it is easiest to wash the canvas while it is installed on your boat.

- Use a soft-bristled brush to remove all dust and loose dirt.
1. Hose down the canvas with freshwater.
 2. Gently wash the canvas with a solution of lukewarm water (no more than 100° F) and non-detergent mild soap, such as Ivory Snow®, Dreft®, or Woolite®.
 3. Rinse thoroughly to remove the soap.
 4. **Before** stowing, let the canvas dry completely.

Stubborn Stains

 CAUTION
<ul style="list-style-type: none"> • Soaking in bleach solutions may remove the waterproof finish of the fabric and may also decrease the life of the polyester thread used in the canvas. • If needed, a water repellent treatment should be reapplied to your canvas. Ask your dealer about the treatments available for your boat's canvas.

Some stubborn stains may resist normal washing and you can try the methods below. However, these methods may remove the waterproof finish of the fabric and may also decrease the life of the polyester thread used in the canvas. Reapply a water repellent treatment as needed.

Method 1

1. Add 1/8 cup (1 oz.) of **non-chlorine** bleach to one gallon of water and mix thoroughly.
2. Thoroughly wet the canvas and then gently scrub the stained area with the weak bleach solution.
3. Rinse with cold water to remove all of the solution.

Method 2

1. Add 1/2 cup (4 oz.) of **non-chlorine** bleach and 1/2 cup (4 oz.) Ivory Snow®, Dreft®, or Woolite® to one gallon of water and mix thoroughly.
2. Soak the canvas in this solution for about 20 minutes.
3. Rinse with cold water to remove all of the solution.

Clear Vinyl Care



CAUTION

- **NEVER** store the clear vinyl pieces wet, as this will cause a milky film to develop.
- **NEVER** fold or crease the clear vinyl pieces as cracking will occur.
- Clear vinyl is **NOT** intended for use when your boat is in storage or being moored.
- Clear vinyl does **NOT** hold up well against ultraviolet rays.
- Under direct sunlight conditions, do **NOT** let the clear vinyl touch the framework. The framework radiates heat and can burn the clear vinyl.

- After each use, especially in saltwater, rinse the clear vinyl with cold freshwater.
- **Before** stowing, the clear vinyl must be completely dry. Air-drying is best, but you can also carefully dry the vinyl with a chamois or soft cotton cloth.
- The clear vinyl can be rolled or laid out flat for stowage.
- **Never** fold or crease the clear vinyl parts as cracking will occur.

Cleaning Clear Vinyl

Regularly clean the clear vinyl to prevent dirt, pollen, and etc. from marring the surface. Generally, it is easiest to clean the clear vinyl while it is installed on your boat.

1. Hose down the clear vinyl with freshwater.
 2. Using a soft cotton cloth (**paper towels are abrasive and should never be used on clear vinyl**), gently wash the clear vinyl with soap and water.
 3. Rinse thoroughly to remove the soap.
 4. **Before** stowing, the clear vinyl must be completely dry. Air-drying is best, but you can also carefully dry the vinyl with a chamois or soft cotton cloth.
- Ask your dealer about products available to keep the clear vinyl polished and looking new.

NEVER FOLD OR CREASE CLEAR VINYL!
FOLDING OR OTHERWISE CREASING
CLEAR VINYL WILL CAUSE DAMAGE
SUCH AS CRACKING TO OCCUR

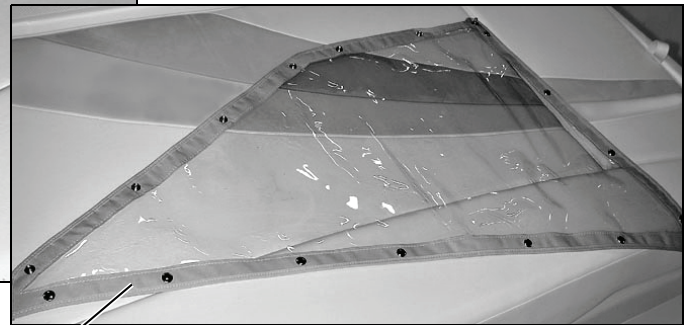
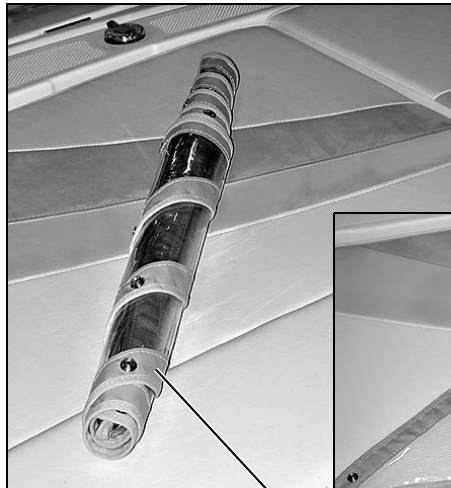
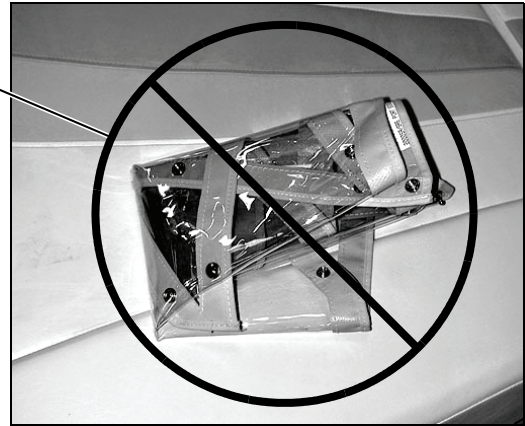

AFTER CLEAR VINYL PARTS HAVE
COMPLETELY AIR DRIED THEY CAN BE
ROLLED OR SIMPLY LAID FLAT FOR STOWAGE

Chapter 8: Appliances & Entertainment Systems

NOTICE

ALWAYS keep an approved ABC-type fire extinguisher in galley area.

- The separate instruction sheets or manuals for *all* appliances and entertainment systems contain detailed information and important safeguards.
- Read these instruction sheets and manuals *before* using your boat's appliances and entertainment systems.
- If applicable, make sure the 110-volt AC breaker is turned **On** for the appliance or entertainment system you wish to use.

Alcohol/110-Volt Electric Stove



DANGER!

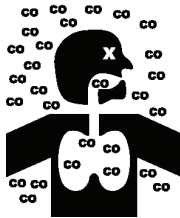

CARBON MONOXIDE POISONING HAZARD!

- The alcohol stove is a source of dangerous carbon monoxide gas (CO).
- **BEFORE** using the alcohol stove, *Open* doors and windows to make sure there is enough fresh air for ventilation.
- Read the *Carbon Monoxide (CO)* section in *Chapter 1* of this supplement.



WARNING!

- Open flame cooking appliances consume oxygen. This can cause asphyxiation or death.
- Maintain open ventilation.



WARNING!



BURN/SCALDING and/or FIRE HAZARD!

- Read the stove's instruction manual **BEFORE** using.
- **ALWAYS** keep an approved ABC-type fire extinguisher in the galley area.
- Do **NOT** use the stove while underway.
- Any non-cooking devices on or near your stove during use are potential fire hazards!
- Do **NOT** touch the burners, grates or nearby surfaces as they may be hot even when they are dark in color.
- Areas near the burners and grates may become hot enough to cause burns.
- During and after use, do **NOT** touch or let clothing or other flammable material come in contact with the heated units or the areas near the units (burner tops, main frame sides and back, sea rails and pot holders) until they have had sufficient time to cool.



CAUTION

PRODUCT DAMAGE HAZARD!

To prevent overheating which can destroy the electric burner elements, **NEVER** try to use both alcohol and electric burners at the same time.

Refrigerator

The refrigerator runs on 12-volt DC power *unless* 110-volt AC power is being supplied by shore power or generator power *and* the refrigerator's circuit breaker on the 110-volt AC master panel is ***On***.

Audio

NOTICE

AM radio reception may be impaired anytime the engine is running.

Chapter 9: Convertible Seats, Beds, & Tables

Dinette to Sleeping Berth Conversion

1. Remove the table (A) and the table leg (B).

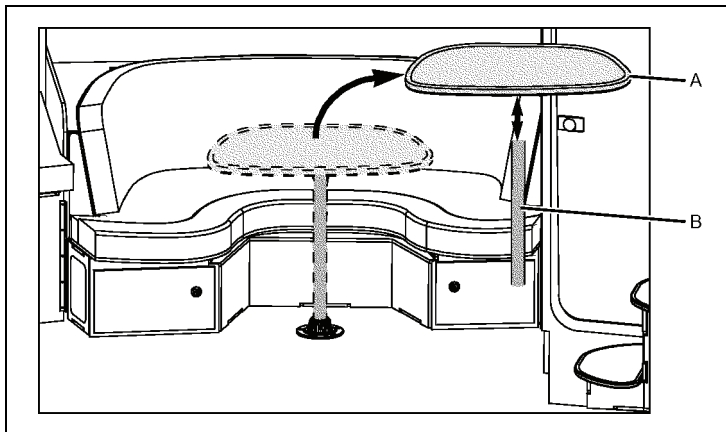

2. Securely store the table leg (B) under the v-berth mattress.

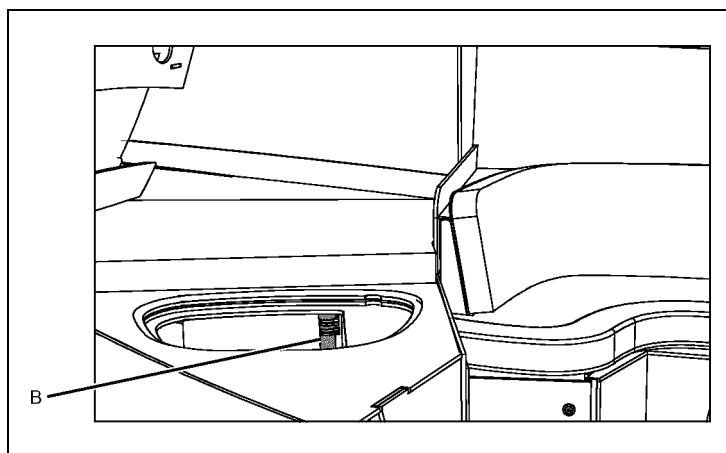

3. Place the shorter table leg (C) into the floor base.

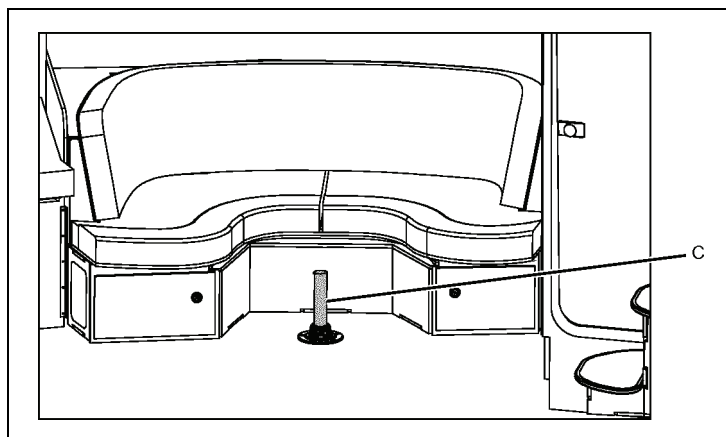

- Place the table (A) so that it fits securely on the short table leg, and on the edge lips at the front of the dinette seats..

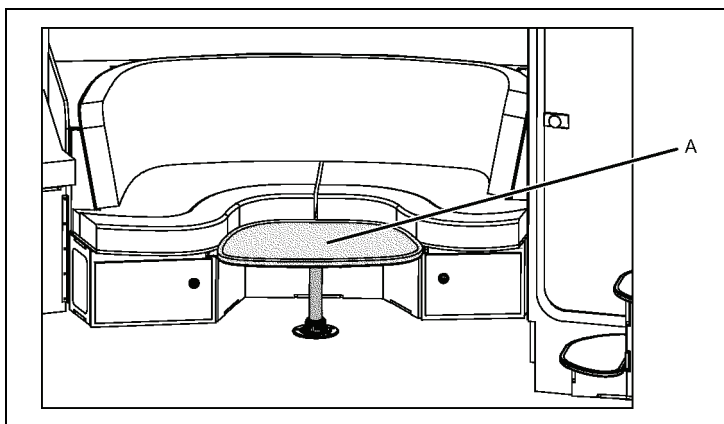

- Place the filler cushions (D) on top of the table.

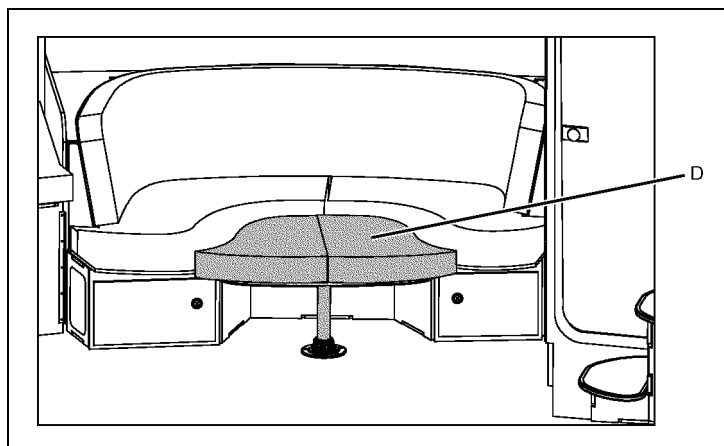

- When not in use, store the table (A) and both table legs (B) under the v-berth mattress.

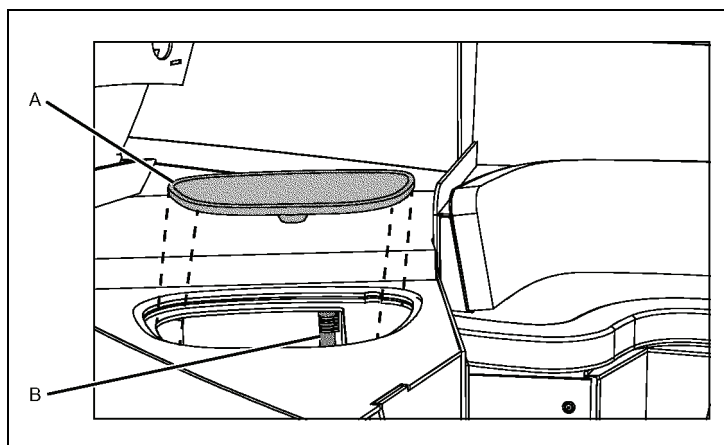

Cockpit Sunlounge Conversion

1. Remove the table (A) and the table leg (B).

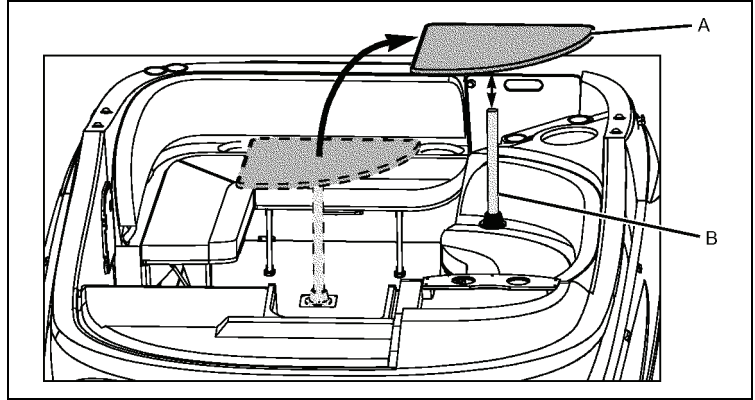

2. Securely store the table leg (B) on the underside of the engine room hatch.

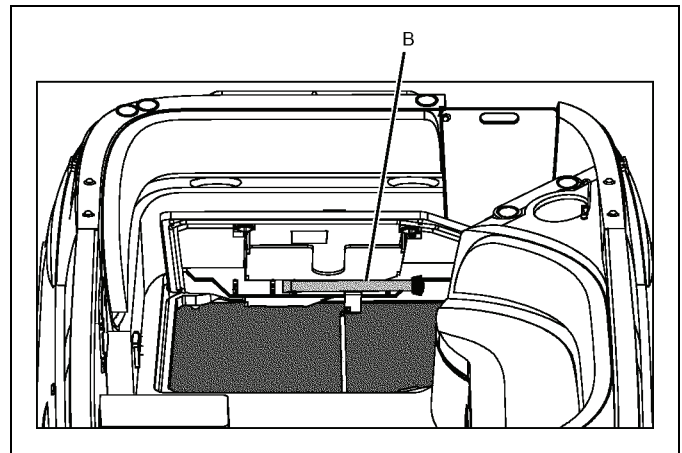

3. Rotate the table supports (C) out and place the shorter table leg (D) into the floor base.

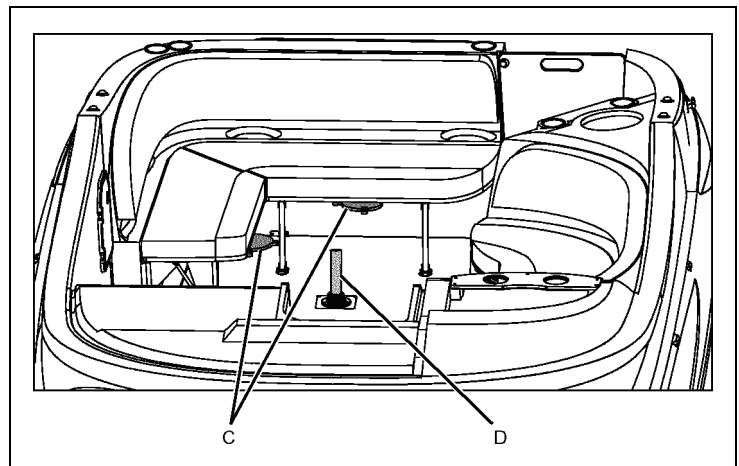

- Place the table (A) so that it fits securely on the table supports and the table leg.

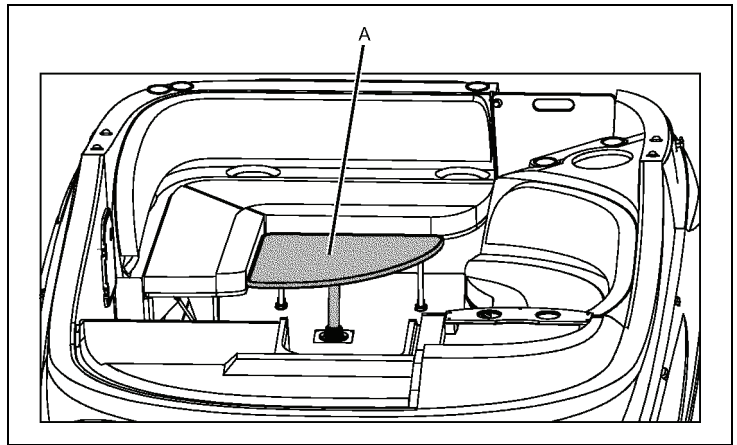

- Place the filler cushion (E) on top of the table.

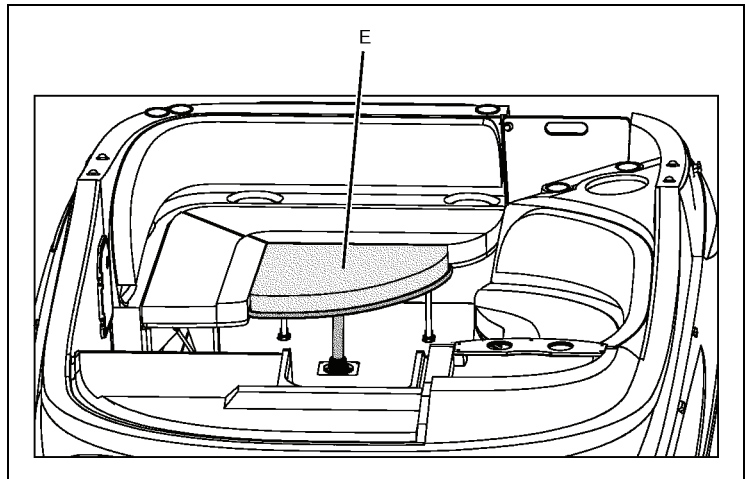

- When not in use, store the table (A) and both table legs (B) on the underside of the engine room hatch.

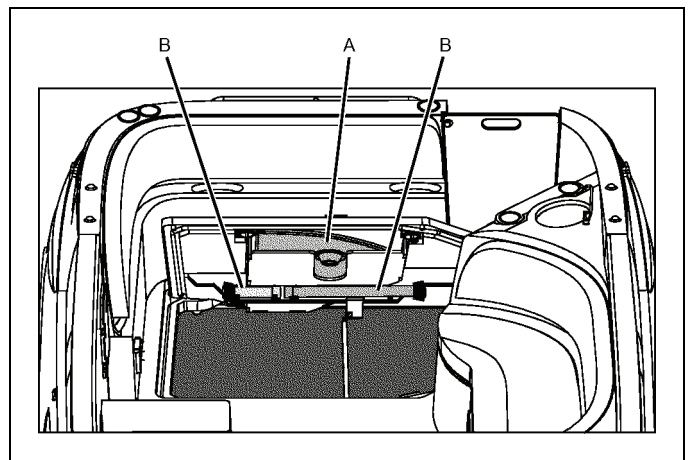

Helm Seat

NOTICE

To rotate the helm seat, it *MUST* be in the forward or center position.

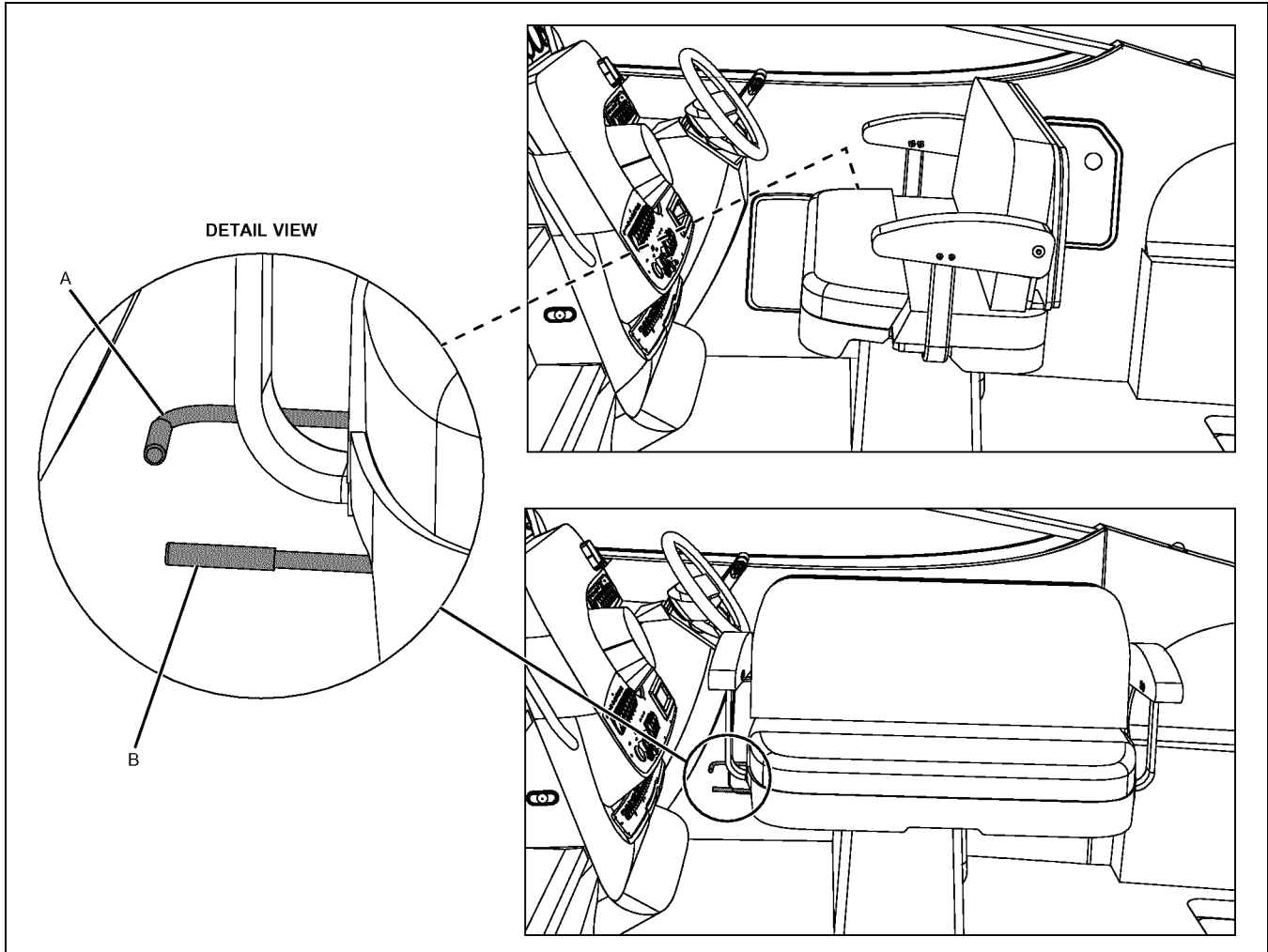

To Slide Helm Seat:

1. Pull the curved lever (A) towards the side panel.
2. Slide the helm seat forward or aft.
3. Push the curved lever back in to lock seat in place.

To Swivel Helm Seat (If Equipped):

1. Push the straight lever (B) forward.
2. Swivel seat.
3. Pull the straight lever back to lock seat in place.

Chapter 10: Lights

Care & Maintenance

All of the lights installed on your boat are of top quality, but you should be aware that failure may periodically occur for a variety of reasons:

1. There may be a blown fuse - *replace the fuse.*
2. The bulb may be burned out - *carry spare replacement bulbs, making sure the wattage is correct.*
3. A wire may be damaged or may have come loose - *repair as required.*
4. The bulb base may be corroded - *clean the base and coat it with non-conductive electrical lubricant.*

Interior & Exterior Lights

 CAUTION
<ul style="list-style-type: none">• Be conservative in the use of battery power.• Prolonged use of cabin interior lights (overnight) <i>WILL</i> result in a drained battery.

- The lights are powered by your boat's 12-volt DC system.
- The battery switch ***must*** be turned ***On*** for the lights to work.

Navigation Lights

 CAUTION
Avoid the storage of gear where it would block navigation lights from view.

NOTICE
Running lights are legally required to show boat direction and right-of-way at night.

Spotlight (If Equipped)

Read the spotlight operating instructions ***before*** using the spotlight.

Chapter 11: Electrical System

⚠ DANGER!

EXTREME FIRE, SHOCK and EXPLOSION HAZARD!



- **NEVER** install non-ignition protected switches or other arcing devices in the fuel compartment.
- **NEVER** substitute automotive parts for marine parts. Marine electrical, ignition, and fuel system parts were designed and manufactured to comply with rules and laws that minimize the risks of fire and explosion.
- **NEVER** change the electrical systems or relevant drawings.
- Allow **ONLY** trained personnel to install batteries and/or do electrical system work.
- Make sure that **ALL** battery switches are turned **Off BEFORE** working in the engine spaces.

⚠ WARNING!

FIRE and EXPLOSION HAZARD!



Fuel vapors can explode! **BEFORE** turning on electrical devices or working on the electrical system:

1. Check the bilge areas for fuel vapors or leaking fuel. If you see leaking fuel or smell fuel vapors:
 - a. Do **NOT** start the engines or generator, do **NOT** turn **On** any electrical devices, put out **ALL** cigarettes, cigars, and other sources of flame or ignition.
 - b. Get everyone off your boat.
 - c. Get trained help to find and fix the problem.
2. Run the bilge blower(s) for at least four minutes **BEFORE** engine starting, electrical system work, or turning on electrical devices.

⚠ CAUTION

SHOCK and ELECTRICAL SYSTEM DAMAGE HAZARD!



When the engines are running, **NEVER** turn **Off** the battery switches or disconnect the battery cables. Doing either could cause damage to your boat's engines and/or electrical system.

NOTICE

Electrical connections are prone to corrosion. To reduce corrosion-caused electrical problems:

- Keep **ALL** electrical connections clean.
- Apply a spray-on protectant that is designed to protect connections from corrosion.

12-Volt DC System

Batteries

- The batteries supply electricity for lights, 12-volt accessories, engine starting and, if equipped, generator starting.
- The *Electrical* section in *Chapter 8* of the *Cruiser & Yacht Owner's Manual* provides battery care and maintenance instructions.

Battery Switches

⚠ CAUTION

⚡ SHOCK and ELECTRICAL SYSTEM DAMAGE HAZARD!

When the engine is running, **NEVER** turn *Off* the battery switch or disconnect the battery cables. Doing either could cause damage to your boat's engine and/or electrical system components.

NOTICE

Make sure your selling dealer fully explains how to use the battery switches.

- Standby-loads, such as the automatic bilge pumps and the stereo memory, are not affected by the battery switch since they are wired directly to the batteries.
- Turn the battery switches to the *Off* position whenever your boat will be unoccupied for long periods of time.
- If an engine will not start because of a dead battery, the emergency battery parallel switch allows you to use the other batteries for engine starting.

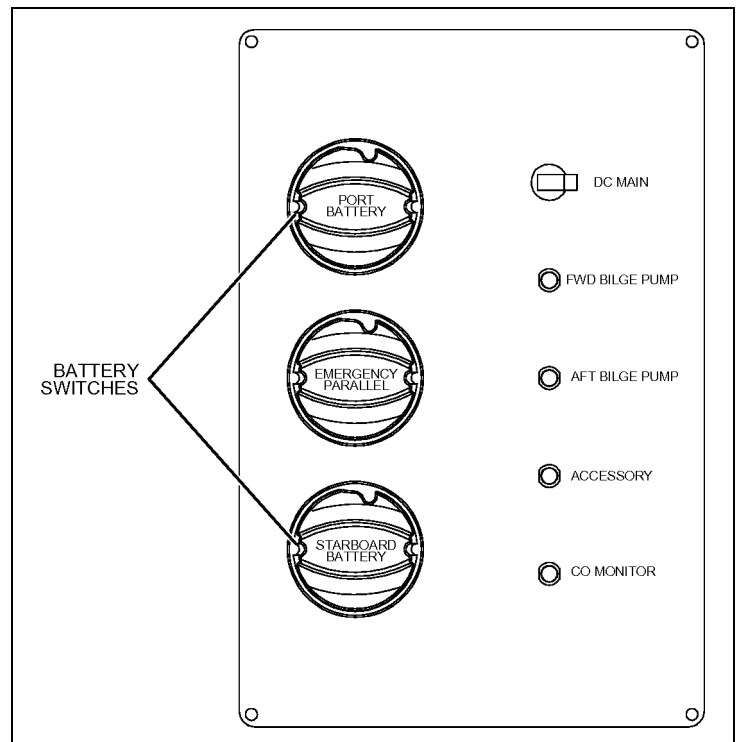

Fuses & Circuit Breakers

- Circuit breakers for engines and main accessory power are on the 12-volt DC push-to-reset circuit breaker panel and on the battery switch panel.
- For the locations of the battery switch panel and the 12-volt DC push-to-reset circuit breakers, see the *Component Locations* section in *Chapter 2* of this supplement.

NOTE: Some equipment may have secondary fuse protection at the unit, behind the battery switch panel, or at the batteries.

12-Volt DC Accessory Outlets



CAUTION

Do **NOT** use the 12-volt DC accessory outlet with a cigarette or cigar lighter. High temperatures may melt the outlet.

- The outlets can be used with any 12-volt device which draws 15-amps or less.
- Each 12-volt DC accessory outlet is protected by a 15-amp breaker on the 12-volt DC push-to-reset circuit breaker panel.
- For the locations of the 12-volt DC accessory outlets, see the *Component Locations* section in *Chapter 2* of this *supplement*.

Alternators

The alternators will keep the batteries properly charged when the engines are running at, or above, cruising speeds.

Battery Charger (If Equipped)



CAUTION

ENGINE and ELECTRICAL SYSTEM DAMAGE HAZARD!

NEVER run your boat's engines and the battery charger at the same time.



CAUTION

- The battery charging systems (alternator and battery charger) installed on your boat are designed to charge conventional lead-acid batteries.
- **BEFORE** installing gel-cell or other new technology batteries, consult with the battery manufacturer about charging system requirements.

- **Before** using the battery charger, read **all** instructions and warnings: (1) on the battery charger, (2) on the batteries, and (3) in the battery charger manual.
- The battery charger will automatically charge your boat's batteries when 110-volt AC power is being provided by shore power or generator power (if equipped), **and** the battery charger circuit breaker on the 110-volt AC master panel is **On**.
- The battery switches can be in any position during charging.
- During battery charging you may use 12-volt accessories, such as the lights and stereo, but battery charging will take longer.

110-Volt AC System

⚠ WARNING!

FIRE and ELECTRICAL SYSTEM DAMAGE HAZARD!

If equipped with a generator, **NEVER** bypass the power source lockouts. Using both shore power and generator power at the same time **WILL** cause major electrical system damage and could start a fire!

- The power source lockouts on the 110-volt AC master panel prevent the use of shore power and generator power at the same time.

⚠ CAUTION

WATER HEATER DAMAGE HAZARD!

- Do **NOT** turn **On** the water heater circuit breaker on the 110-volt AC master panel until the water heater tank is **COMPLETELY** filled with water.
- The tank is full if water flows from the tap when the hot water is turned **On** in the galley.
- Even brief water heater operation with a dry tank **WILL** damage the heating elements.
- Warranty replacements will **NOT** be made on elements damaged in this manner.

NOTICE

- Whether using shore power or generator power, the use of several 110-volt AC accessories at the same time can result in an overloaded circuit.
- You may have to turn **Off** one or more accessories to use another accessory.

- To gain a basic understanding of your boat's 110-volt AC system, read the handbook, *A Boater's Guide To AC Electrical Systems*. If this handbook is not in your owner's packet, call 360-435-8957 and the handbook will be mailed to you.
- The 110-volt AC system can be energized by shore power, or generator power (if equipped).
- Individual breakers on the 110-volt AC master panel **must** be turned **On** to supply power to the accessories you wish to use.
- The 110-volt AC master panel may contain circuit breakers for accessories that are **not** available for your boat.

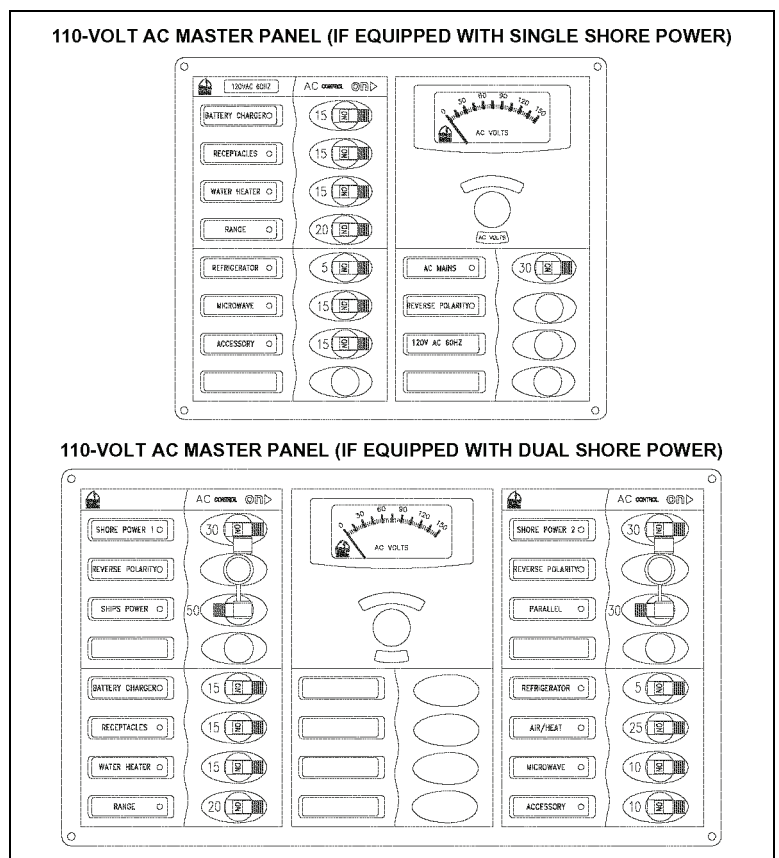



Shore Power

DANGER!



FIRE, EXPLOSION and SHOCK HAZARD!

- Use **ONLY** compatible shore power connectors and **NEVER** alter the connectors.
- Turn **Off ALL** breakers and switches on the 110-volt AC master panel **BEFORE** plugging in or unplugging the shore power cord.
- To prevent shock or injury from dropping a "hot" cord into the water:
 - a. **ALWAYS** plug the shore power cord into the boat inlet first, and then into the dockside outlet.
 - b. When unplugging from shore power, **ALWAYS** unplug the shore power cord from the dockside outlet first.
- **NEVER** leave the shore power cord plugged into the dockside outlet **ONLY**.
- **ONLY** use shore power cords approved for marine use. **NEVER** use ordinary indoor or outdoor extension cords.

WARNING!



SHOCK and ELECTRICAL SYSTEM DAMAGE HAZARD!

- Monitor the polarity indicator lights **EVERY TIME** you connect to shore power.
- If a reversed polarity light turns **On** when you are connecting to shore power, do **NOT** turn **On** the main breaker switches.
- Instead, **IMMEDIATELY** unplug the shore power cord (**ALWAYS** from the dockside outlet first) and alert marina management.

WARNING!

SHOCK and ELECTRICAL SYSTEM DAMAGE HAZARD!

- **BEFORE** each use, check the shore power cord for defects or damage.
- **NEVER** use a damaged or faulty cord since the danger of fire and electrical shock exists.
- Do **NOT** pinch the shore power cord in doors or hatches, or coil the shore power cord too tightly, since these situations can generate enough heat to result in a fire.
- If a shore power cord is dropped into the water, **COMPLETELY** dry the blades and contact slots **BEFORE** using.

CAUTION

ELECTRICAL SYSTEM DAMAGE HAZARD!

- **NEVER** connect to dockside power outside of North America unless you have the international electrical conversion option.
- Using several 110-volt AC accessories at the same time can result in an overloaded circuit. You may have to turn **Off** one or more accessories to use another accessory.
- Use double insulated or three-wire protected electrical appliances whenever possible.

- Single shore power 110-volt/60-hertz AC systems feature one 110-volt/30-amp shore power inlet.
- If your boat has an air conditioning system, a second (dual) 110-volt/30-amp inlet has been installed.
- Dual shore power inlets are labeled LINE 1 and LINE 2, which corresponds to the SHORE POWER 1 and SHORE POWER 2 master breakers on the 110-volt AC master panel.
- LINE 1 and LINE 2 are independent of each other except when the parallel switch is used.

Connecting to Shore Power

WARNING!

SHOCK and ELECTRICAL SYSTEM DAMAGE HAZARD!



- Monitor the polarity indicator lights *EVERY TIME* you connect to shore power.
- If a reversed polarity light turns *On* when you are connecting to shore power, do *NOT* turn *On* the main breaker switches.
- Instead, *IMMEDIATELY* unplug the shore power cord (*ALWAYS* from the dockside outlet first) and alert marina management.

1. Review *all* hazard information at the beginning of this section, *Shore Power*.
2. Turn *Off* the shore power master circuit breaker(s) and *all* switches and breakers on the 110-volt AC master panel.
3. Attach the shore power cord(s) to the boat inlet(s) first, then to the dockside outlet(s).
4. Turn *On* the SHORE POWER 1 and SHORE POWER 2 (if equipped) master breaker(s) on the 110-volt AC master panel.
5. As needed, turn *On* the individual component breakers on the 110-volt AC master panel.

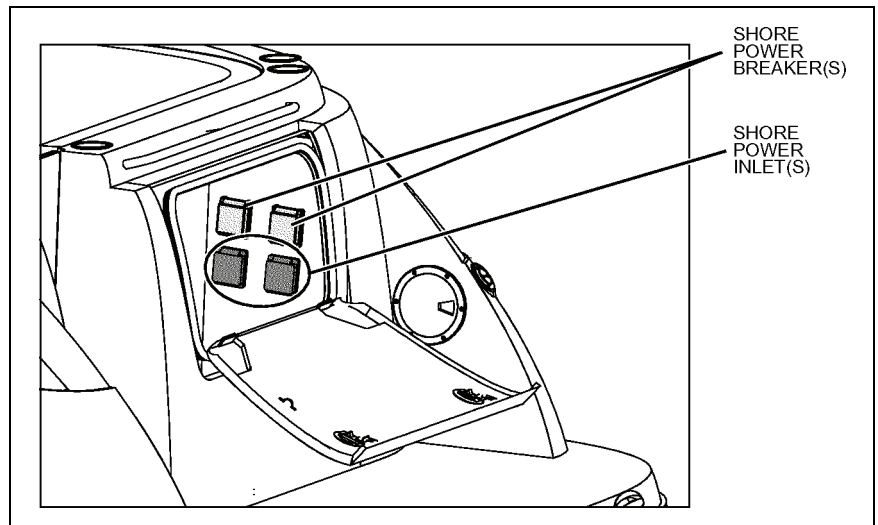

Parallel Switch (Only if Equipped with Dual Shore Power)

NOTICE



- When using the parallel switch do *NOT* exceed 30 total amps.
- The amperage of each component breaker is shown on the breaker itself.
- The voltage on each line can be read on the voltmeter on the 110-volt AC master panel.

When only one dockside outlet is available, you can use the parallel switch to provide power to both lines.

1. Connect to shore power as described in the *Connecting to Shore Power* section above.
2. Switch the parallel switch (transfers power from line 1 to line 2) *On* instead of the SHORE POWER 2 master breaker.
3. Turn *On* the individual component breakers as required.

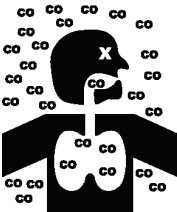
Generator (If Equipped)

 DANGER!	
	<p>CARBON MONOXIDE POISONING HAZARD!</p> <ul style="list-style-type: none"> Generators are a source of dangerous carbon monoxide gas (CO). Check the generator exhaust system for leaks <i>BEFORE</i> each use. Read the <i>Carbon Monoxide (CO)</i> section in <i>Chapter 1</i> of this supplement.

 WARNING!	
	<p>FIRE and EXPLOSION HAZARD!</p> <p>Fuel vapors can explode! <i>BEFORE</i> starting the generator:</p> <ol style="list-style-type: none"> Check the bilge areas for fuel vapors or leaking fuel. If you see leaking fuel or smell fuel vapors: <ol style="list-style-type: none"> Do <i>NOT</i> start the generator or the engines, do <i>NOT</i> turn <i>On</i> any electrical devices, and put out <i>ALL</i> cigarettes, cigars, and other sources of flame or ignition. Get everyone off your boat. Get trained help to find and fix the problem. Run the bilge blower(s) for at least four minutes <i>BEFORE</i> generator or engine starting, electrical system work, or turning on electrical devices. <ul style="list-style-type: none"> If you smell fuel vapors and the generator is already running: <ol style="list-style-type: none"> Shut <i>Off</i> the generator and turn <i>Off ALL</i> electrical devices. Put out <i>ALL</i> cigarettes, cigars, and other sources of flame or ignition. Get trained help to find and fix the problem.

 CAUTION	
<p>SYSTEM DAMAGE HAZARD!</p> <ul style="list-style-type: none"> <i>ALWAYS</i> make sure the generator's seawater intake seacock is <i>Open BEFORE</i> starting, and during running of the generator. <i>NEVER</i> run the generator starter for more than 30 seconds. If the generator does not start, wait at least 30 seconds <i>BEFORE</i> trying again. After the generator starts, let the generator stabilize <i>BEFORE</i> turning <i>On</i> the component breakers on the 110-volt AC master panel. 	

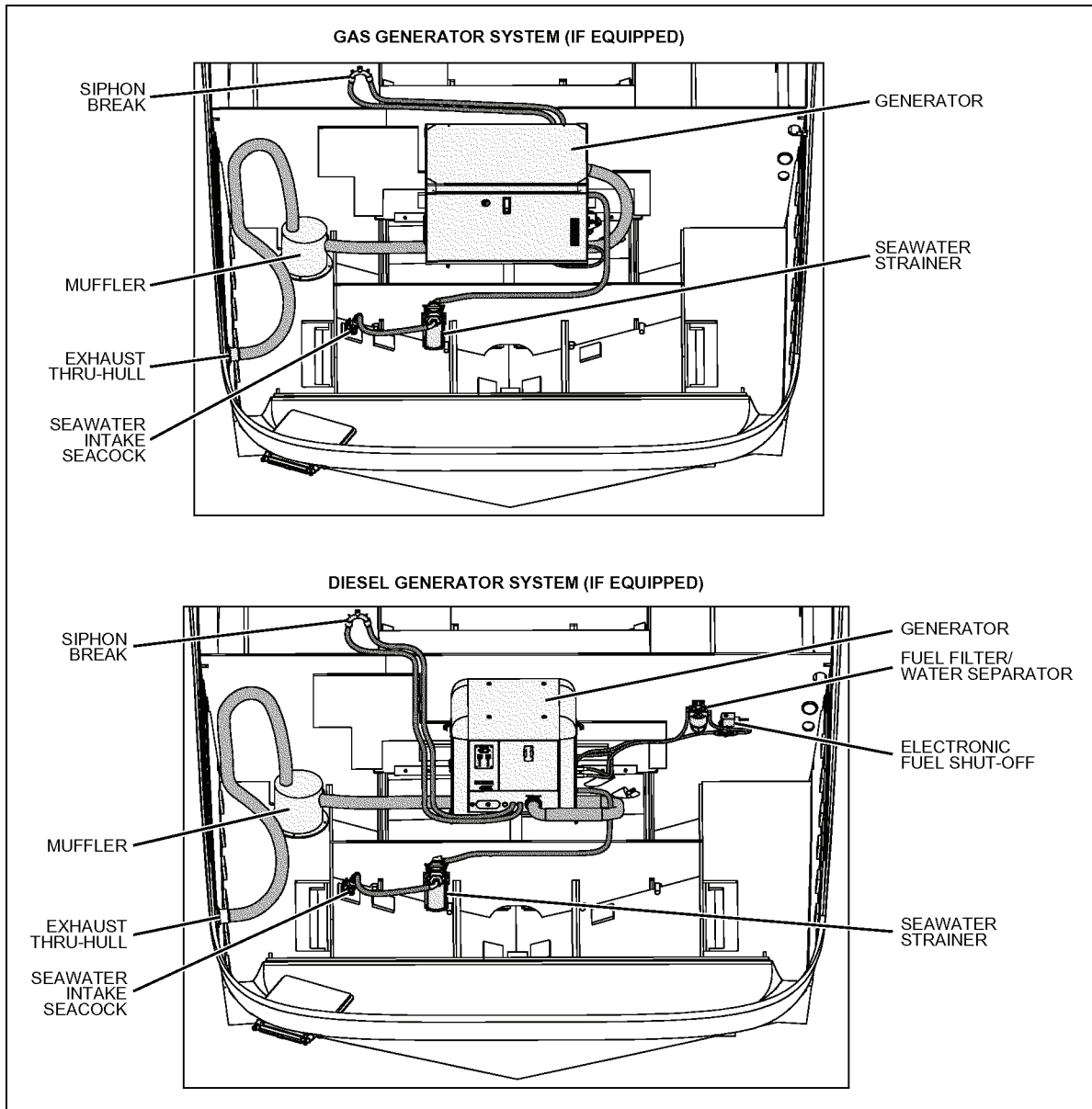

- When your boat is **not** connected to shore power, the generator can supply 110-volt/60-hertz power.
- **Before** using the generator, read the generator operation manual for pre-start checks and break-in procedures.
- **Refer to the generator manual for starting/stopping instructions.**

Important generator notes:

- Polarity has been established in the installation of the generator. Therefore the polarity lights will **not** function in this mode.
- Fuel to run the generator is supplied from the fuel tank.
- Periodically replace the fuel filter on the generator to make sure it remains clean and free of debris.
- Diesel generators also have a fuel filter/water separator. Service instructions are provided on the fuel filter/water separator.
- The coolant mixture installed at the factory consists of equal parts of water and antifreeze (Ethylene Glycol).
- Check the generator's seawater strainer for leaks and/or debris **before** each use.

Electrical Routings

12-Volt DC Hull Harness

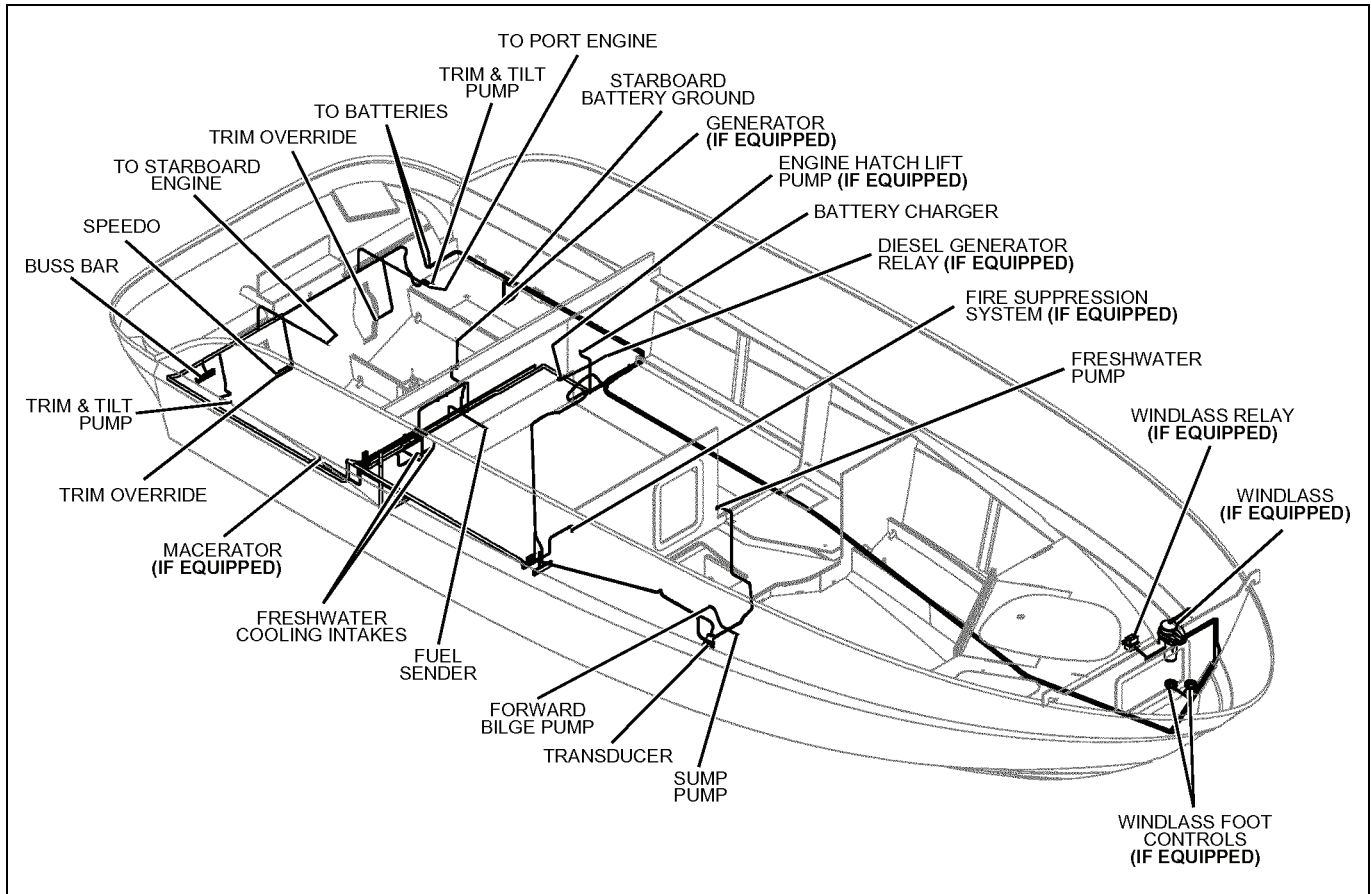

12-Volt DC Deck Harnesses

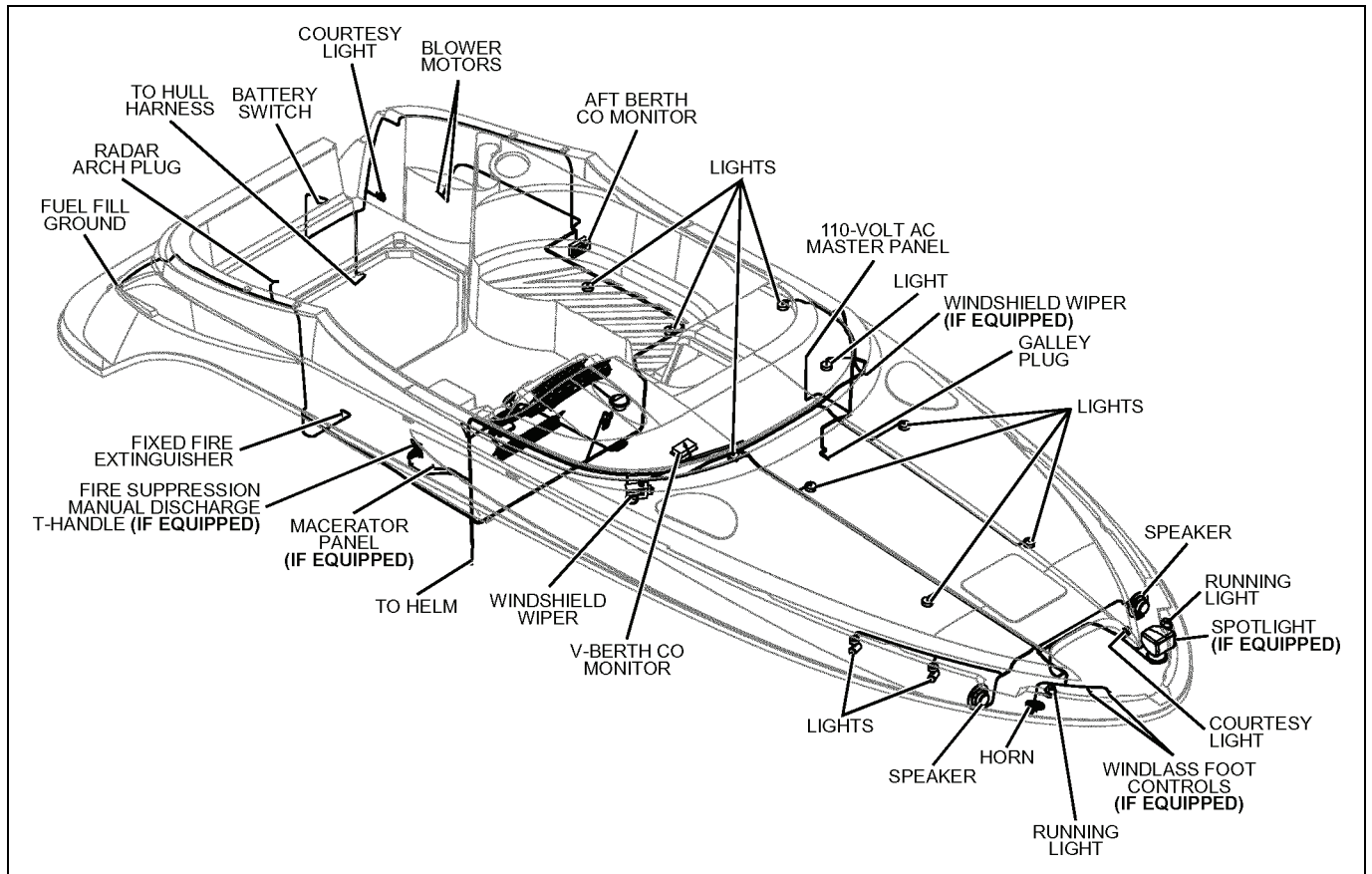

12-Volt DC Radar Arch Harness

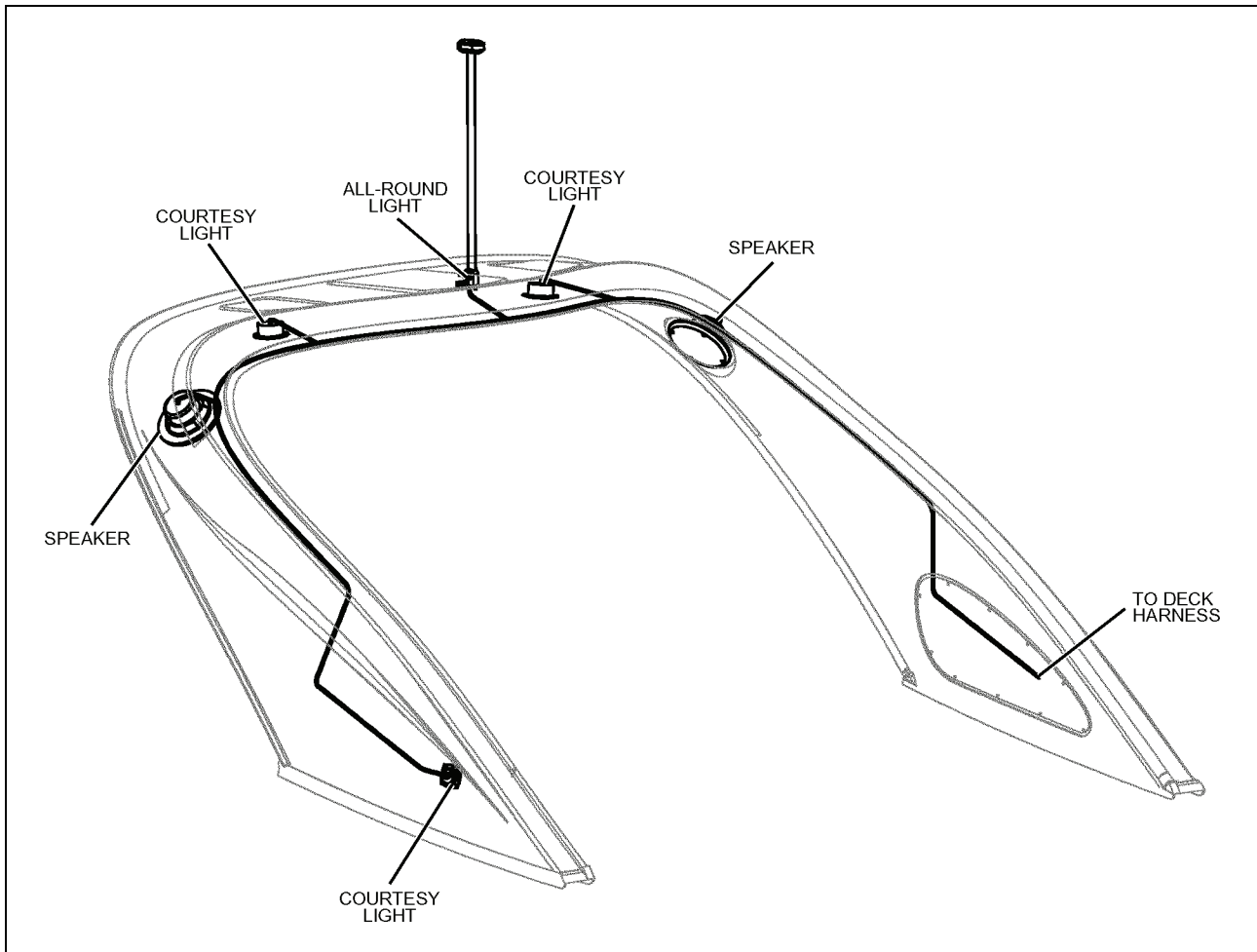

Battery Cable Routings

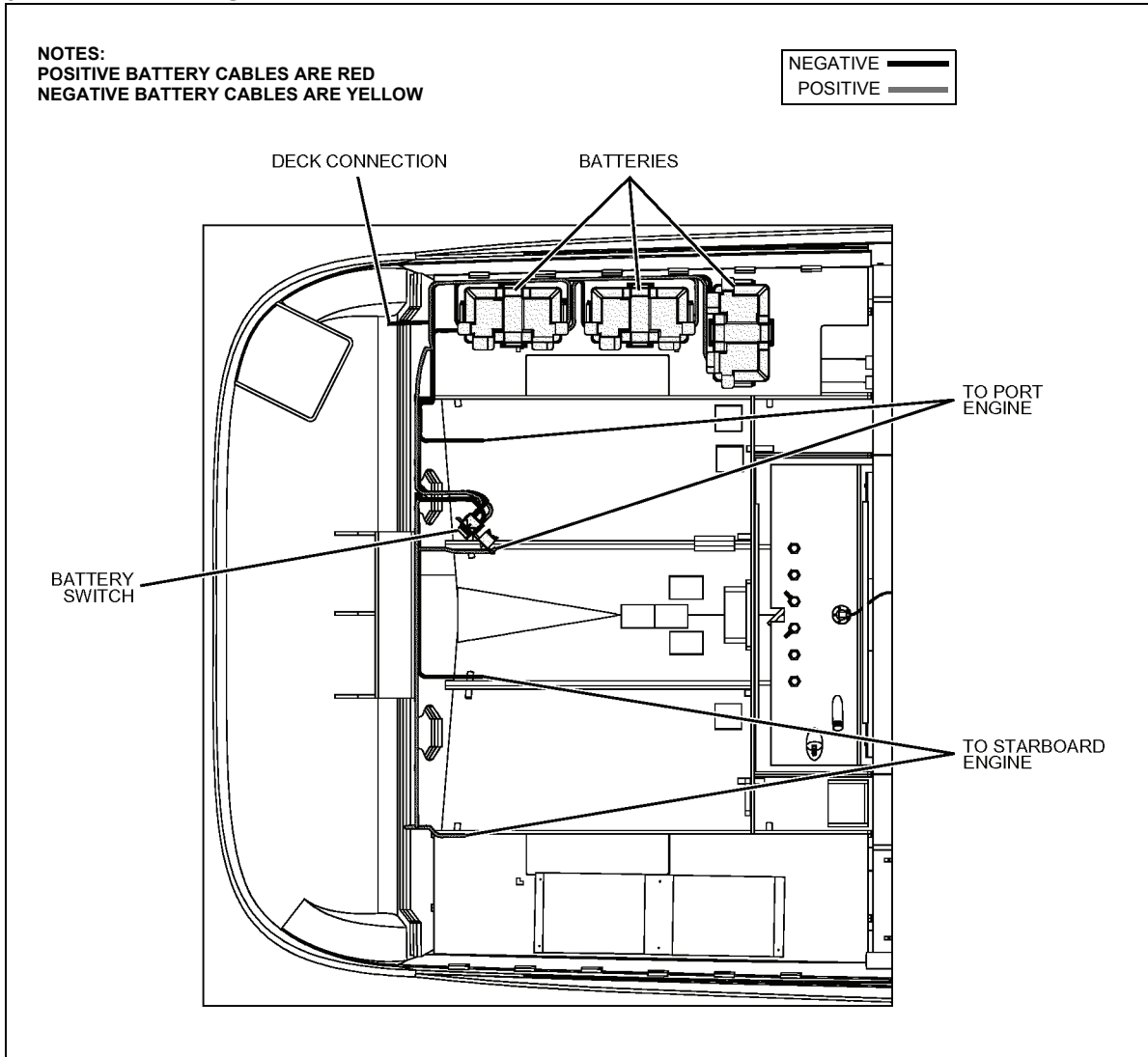

110-Volt AC Hull Harnesses

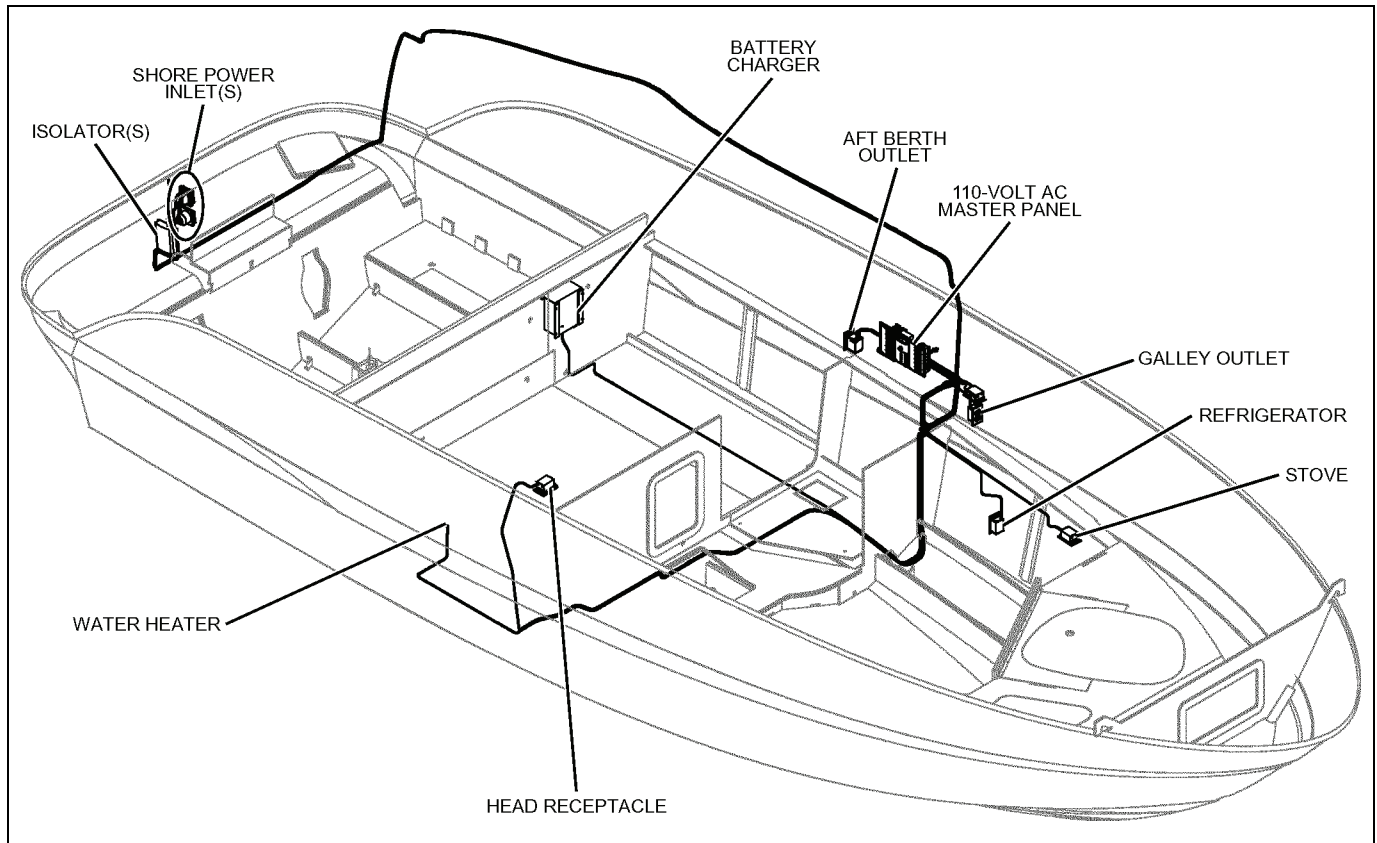

Important Records

Selling Dealer

Name Of Dealership

Address

Phone/FAX/E-mail

Sales Manager

Service Manager

Engines

Manufacturer

Model Name/Number

Port Engine Serial Number

Starboard Engine Serial Number

Oil Type/SAE

Quarts per Engine

Filter Type

Propellers

Manufacturer

Pitch

Model Number

Key Numbers

Ignition

Other

Electronics

Manufacturer

Model Name/Number

Serial Number

Manufacturer

Model Name/Number

Serial Number

Manufacturer

Model Name/Number

Serial Number

Manufacturer

Model Name/Number

Serial Number

Float Plan

Before going boating, fill out a copy of this float plan (or similar) and leave it with a **reliable** person whom you can depend on to contact the Coast Guard or other rescue organization, if you do not return as scheduled.

Description of Boat

Registration/Documentation Number		
Length	Make	Type
Hull Color		Trim Color
Fuel Capacity	Engine Type	Number of Engines
Distinguishing Features		
Distinguishing Features		

Full Name		
Age	Health	Phone Number
Full Name		
Age	Health	Phone Number
Full Name		
Age	Health	Phone Number

Operator of Boat

Full Name		
Male or Female	Age	Health
Address		
Address		
Phone/FAX/E-mail		
Operator's Experience		

Full Name		
Age	Health	Phone Number
Full Name		
Age	Health	Phone Number
Full Name		
Age	Health	Phone Number

Persons Onboard

Full Name		
Age	Health	Phone Number
Full Name		
Age	Health	Phone Number

Full Name		
Age	Health	Phone Number
Full Name		
Age	Health	Phone Number

Survival Equipment

Marine Radio (Yes/No)	Type	Frequencies
Number of PFDs	Flares (Yes/No)	Mirror (Yes/No)
Smoke Signals (Yes/No)	Flashlight (Yes/No)	Food (Yes/No)
Water (Yes/No)	Anchor (Yes/No)	Raft/Dinghy (Yes/No)
Paddles (Yes/No)	EPIRB (Yes/No)	Other
Other	Other	Other

Vehicle Description

Make	Model
Color	License Number
Where is the Vehicle Parked?	

Trip Expectations

Departing From	
Departure Date	Departure Time
Stopover 1	
Arrive No Later Than: Date	Arrive No Later Than: Time
Stopover 2	
Arrive No Later Than: Date	Arrive No Later Than: Time
Stopover 3	
Arrive No Later Than: Date	Arrive No Later Than: Time
Stopover 4	
Arrive No Later Than: Date	Arrive No Later Than: Time
Stopover 5	
Arrive No Later Than: Date	Arrive No Later Than: Time
Stopover 6	
Arrive No Later Than: Date	Arrive No Later Than: Time
Final Destination Port (If Different Than Home Port)	
Arrive No Later Than: Date	Arrive No Later Than: Time

If not returned by the date and time listed above, call the Coast Guard or other local authority.

Coast Guard Phone Number
Local Authority Phone Number

Part Number 2016134

Bayliner • 17825 59th Ave NE • Arlington, WA 98223 • 360-435-5571