

**BAYLINER<sup>®</sup>**

**2252 Classic Cruiser**

Owner's Manual *Supplement*



**Engine Serial Number:** \_\_\_\_\_

**Hull Identification Number:** \_\_\_\_\_

***Hull Identification Number***

- The Hull Identification Number (HIN) is located on the starboard side of the transom.
- Record the HIN (and the engine serial numbers) in the space provided above.
- Include the HIN with any correspondence or orders.

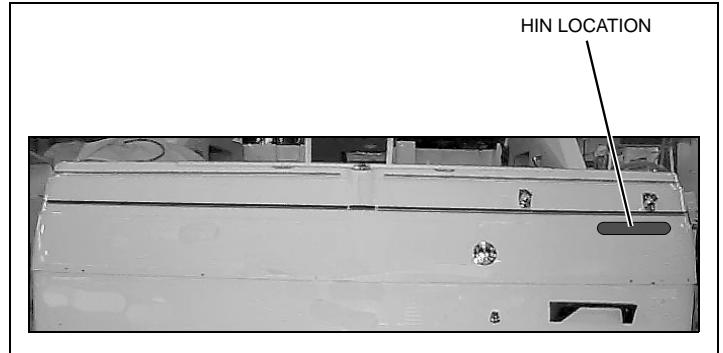

**© 2003 Bayliner Technical Publications. All rights reserved.**

No part of this publication may be reproduced, stored in any retrieval system, or transmitted in any form by any means, electronic, mechanical, photocopying, recording or otherwise, without prior written permission of Bayliner.

Printed in the United States of America.

**General Notes**

The material in this document is for information only and is subject to change without notice. While reasonable efforts have been made in the preparation of this document to assure its accuracy, Bayliner assumes no liability resulting from errors or omissions in this document, or from the use of information contained herein.

Due to our commitment to product improvement, Bayliner reserves the right to make changes in the product design, specifications, and equipment at any time without notice or obligation. Illustrations and/or photos may show optional equipment.

All Bayliner products meet or exceed USCG (United States Coast Guard) and/or NMMA (National Marine Manufacturer's Association) construction standards. Manufactured with 1,1,1 Trichloroethane, a substance which harms public health and environment during the manufacturing process by destroying ozone in the upper atmosphere.

**Proprietary Rights**

This document discloses subject matter in which Bayliner has proprietary rights. The information and design disclosed herein were originated by and are the property of Bayliner. Neither receipt nor possession thereof confers or transfers any right to reproduce, copy, alter or disclose the document or any part thereof, any information contained therein, or to construct boats or any item from it, except by written permission from or written agreement with Bayliner. This document is to be returned upon request to Bayliner.

# CONTENTS

---

## **1 Chapter 1: Welcome Aboard!**

- 1 Dimensions and Tank Capacities
- 1 Layout View
- 1 Dealer Service
- 1 Warranty Information
- 2 Boating Experience
- 2 Safety Standards
- 3 Engine & Accessories Guidelines
- 3 Engine & Accessories Literature
- 3 Qualified Maintenance
- 3 Structural Limitations
- 4 Special Care For Moored Boats
- 4 Sacrificial Anodes (Zincs)
- 5 Carbon Monoxide (CO)
  - 5 *Facts about CO*
  - 6 *Where and How CO Can Accumulate*
  - 6 *How to Protect Yourself and Others From CO*
  - 7 *Trip Checklist*
  - 7 *Monthly Checklist*
  - 7 *Annual Checklist*
  - 8 *Carbon Monoxide Alarm System*
  - 8 *More Information*

## **9 Chapter 2: Locations**

- 9 Exterior Views
  - 9 *Hull Views*
  - 10 *Deck View*
  - 11 *Helm*
- 12 Component Locations

## **13 Chapter 3: Propulsion & Related Systems**

- 13 Engine
- 13 Engine Room Ventilation System
- 14 Fuel System
  - 15 *Fuel Fill and Vent*
  - 15 *Fuel Filters*
  - 15 *Anti-siphon Valve*
- 16 Quick Oil Drain System

## **17 Chapter 4: Controls**

- 17 Steering
- 17 Shift/Throttle
- 17 Power Trim and Tilt
- 18 Trim Tabs (If Equipped)

## **19 Chapter 5: Plumbing**

- 19 Drain Systems
  - 19 *Deck Drains*
  - 19 *Galley Sink Drain*
- 20 Bilge Pumps
  - 22 *Autofloat Switches*
- 23 Seawater Systems
  - 23 *Seacocks*
  - 23 *Seawater Strainers*
- 24 Freshwater System
- 25 Marine Head with Holding Tank (If Equipped)
  - 26 *Macerator (If Equipped)*

---

**27 Chapter 6: Deck Equipment**

27 Cleats and Tow Eyes

**28 Chapter 7: Entertainment Systems**

28 Audio System

**29 Chapter 8: Convertible Seats,  
Beds, & Tables**

29 Sleeper Seat Adjustment

30 Dinette/V-Berth

**31 Chapter 9: Lights**

31 Care and Maintenance

31 Navigation Lights

31 Interior & Exterior Lights

**32 Chapter 10: Electrical System**

33 12-Volt DC System

33 *Batteries*

33 *Fuses and Circuit Breakers*

33 *Alternator*

33 *12-Volt Accessory Outlet*

34 Electrical Routings

34 *Hull Electrical Harness*

34 *Deck Electrical Harness*

35 *Hardtop Harness (If Equipped)*

36 Wire Diagram

36 *Engine Electrical System*

**37 Important Records**

**38 Float Plan**

## Hazard Boxes & Symbols

The hazard boxes and symbols shown below are used throughout this Supplement to call attention to potentially dangerous situations which could lead to either personal injury or product damage. **Read ALL warnings carefully and follow all safety instructions.**

 **DANGER!**  
This box alerts you to immediate hazards which *WILL* cause severe personal injury or death if the warning is ignored.

 **WARNING!**  
This box alerts you to hazards or unsafe practices which *COULD* result in severe personal injury or death if the warning is ignored.

 **CAUTION!**  
This box alerts you to hazards or unsafe practices which *COULD* result in minor personal injury or cause product or property damage if the warning is ignored.

**NOTICE**  
This box calls attention to installation, operation or maintenance information, which is important to proper operation but is not hazard related.



# Chapter 1: Welcome Aboard!

This *Owner's Manual Supplement* provides specific information about your boat that is **not** covered in the *Cruiser & Yacht Owner's Manual*. Please study the *Cruiser & Yacht Owner's Manual* and this *Supplement* carefully. Keep the *Cruiser & Yacht Owner's Manual* and this *Supplement* on your boat in a secure, yet readily available place.

## Dimensions and Tank Capacities

Overall Length	Bridge Clearance	Beam	Draft (Drive Up)	Draft (Drive Down)	Fuel Capacity (gal.)	Freshwater Capacity (gal.)	Waste Holding Tank Capacity (gal.)
22' 3"	7' 8"	8' 1"	1' 5"	2' 10"	55	13	13

## Layout View

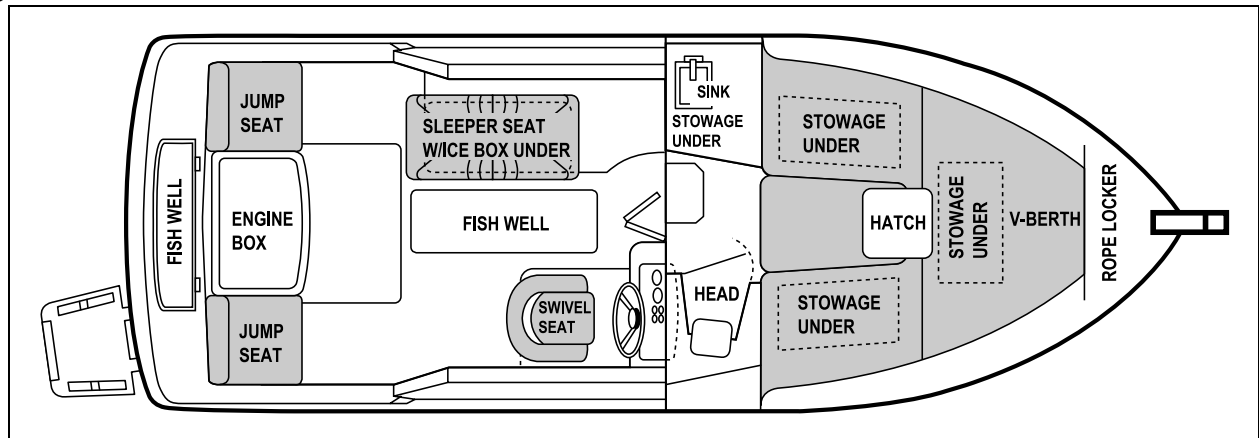

## Dealer Service

- Ask your dealer to explain **all** systems **before** taking delivery of your boat.
- Your dealer is your key to service.
- Contact your dealer if you have any problems with your new boat.
- If your dealer cannot help, call our customer service hotline: 360-435-8957 or send us a FAX: 360-403-4235.
- Buy replacement parts from any authorized Bayliner dealer.

## Warranty Information

- Bayliner offers a Limited Warranty on each new Bayliner purchased through an authorized Bayliner dealer.
- A copy of the Limited Warranty was included in your owner's packet.
- If you did not receive a copy of the Limited Warranty, please contact your dealer or call 360-435-8957 for a copy.

## Boating Experience

 <b>WARNING!</b>
<p><b>CONTROL HAZARD!</b></p> <p>A qualified operator <i>must</i> be in control of the boat at <i>all</i> times. <b>DO NOT</b> operate your boat while under the influence of alcohol or drugs.</p>



If this is your first boat or if you are changing to a type of boat you are *not* familiar with, for your own comfort and safety, obtain handling and operating experience before assuming command of the boat.



Take one of the boating safety classes offered by the U.S. Power Squadrons or the U.S. Coast Guard Auxiliary. For more course information, including dates and locations of upcoming classes, contact the organizations directly:

- U.S. Power Squadrons: 1-888-FOR-USPS (1-888-367-8777) or on the Internet at: <http://www.usps.org>
- U.S. Coast Guard Auxiliary: 1-800-368-5647 or on the Internet at: <http://www.cgaux.org>

Outside the United States, your selling dealer, national sailing federation or local boat club can advise you of local sea schools or competent instructors.

## Safety Standards

 <b>DANGER!</b>	
	<p><b>FALLING and ROTATING PROPELLER HAZARD!</b></p> <p><b>NEVER</b> allow anyone to ride on parts of the boat <i>not</i> designed for such use.</p> <ul style="list-style-type: none"> <li>• Sitting on seat backs, lounging on the forward deck, bow riding, gunwale riding or occupying the transom platform while underway is especially hazardous and <i>will</i> cause personal injury or death.</li> </ul>

 <b>DANGER!</b>	
 <p><b>DANGER</b> CARBON MONOXIDE</p>	
<p><b>ROTATING PROPELLER and CARBON MONOXIDE POISONING HAZARD!</b></p> <ul style="list-style-type: none"> <li>• <b>NEVER</b> allow anyone to occupy, or hang from, the back deck or swim platform while the engine(s) are running.</li> <li>• Teak surfing, dragging, or water skiing within 20 feet of a moving watercraft can be fatal.</li> </ul>	

 <b>DANGER!</b>	
<p><b>PERSONAL SAFETY HAZARD!</b></p> <p><b>ALWAYS</b> secure the anchor and other loose objects <i>before</i> getting underway. The anchor and other items that are <i>not</i> properly secured can come loose when the boat is moving and cause personal injury or death.</p>	

Your boat's mechanical and electrical systems were designed to meet safety standards in effect at the time it was built. Some of these standards were mandated by law, all of them were designed to insure your safety, and the safety of other people, vessels and property.

In addition to this *Owner's Manual Supplement*, please read the *Cruiser & Yacht Owner's Manual* and *all* accessory instructions for important safety standards and hazard information.



## Engine & Accessories Guidelines

### NOTICE

When storing your boat please refer to your engine's operation and maintenance manuals.

- Your boat's engine and accessories were selected to provide optimum performance and service.
- Installing a different engine or other accessories may cause unwanted handling characteristics.
- Should you choose to install a different engine or to add accessories that *will* affect the boat's running trim, have an experienced marine technician perform a safety inspection and handling test before operating your boat again.

**Certain modifications to your boat can result in cancellation of your warranty protection. Always** check with your dealer before making any modifications to your boat.

## Engine & Accessories Literature

- The engine and accessories installed on your boat come with their own operation and maintenance manuals.
- Read and understand these manuals *before* using the engine and accessories.
- Unless noted otherwise, *all* engine and accessory literature referred to in this *Supplement* is included in your owner's packet.

## Qualified Maintenance



### WARNING!

To maintain the integrity and safety of your boat, allow *only* qualified personnel to perform maintenance on, or in any way modify: The steering system, propulsion system, engine control system, fuel system, environmental control system, electrical system or navigational system.

Failure to maintain your boat's systems (listed in the warning above) as designed could violate the laws in your jurisdiction and could expose you and other people to the danger of bodily injury or accidental death. Follow the instructions provided in the *Cruiser & Yacht Owner's Manual*, this *Owner's Manual Supplement*, the engine owner's manual and *all* accessory instruction sheets and manuals included in your boat's owner's packet.

## Structural Limitations

The transom platform and bow platform are designed to be lightweight for proper boat balance. The load limit for these platforms is 30 pounds per square foot, evenly distributed.

## Special Care For Moored Boats

### NOTICE

- **To help seal the hull bottom and reduce the possibility of gelcoat blistering on moored boats, apply an epoxy barrier coating. The barrier coating should be covered with several coats of anti-fouling paint.**
- **Many states regulate the chemical content of bottom paints in order to meet environmental standards. Check with your local dealer about recommended bottom paints, and about the laws in effect in your area.**

Whether moored in saltwater or freshwater, your boat *will* collect marine growth on its hull bottom. This *will* detract from the boat's beauty, greatly affect its performance and may damage the gelcoat. There are two methods of slowing marine growth:

- Periodically haul the boat out of the water and scrub the hull bottom with a bristle brush and a solution of soap and water.
- The hull below the waterline may have anti-fouling paint applied by the factory. Occasionally you *will* need to re-paint it with a good grade of anti-fouling paint.

## Sacrificial Anodes (Zincs)

### NOTICE

***Do not* paint between the zinc and the metal surface it contacts and *do not* paint over the zincs.**



Your boat is equipped with sacrificial anodes (zincs) to protect underwater metal parts from excessive deterioration. Check the zincs regularly and replace them if they have deteriorated more than 70%.

There are many factors that affect the rate at which the zincs deteriorate, including:

- Water temperature
- Salinity
- Water pollution

Stray electrical current from the boat or dock may cause complete deterioration in just a few weeks. If there is rapid zinc deterioration, measure the electrolytic corrosion around your boat with a Corrosion Test Meter. If the zincs are *not* bonded correctly, they *will not* provide protection.

## Carbon Monoxide (CO)

 <b>DANGER!</b>	
	<ul style="list-style-type: none"> <li>• Carbon monoxide gas (CO) is colorless, odorless, tasteless, and extremely dangerous.</li> <li>• <i>All</i> engines, generators, and fuel burning appliances produce CO as exhaust.</li> <li>• Prolonged exposure to low concentrations or very quick exposure to high concentrations <i>will</i> cause BRAIN DAMAGE or DEATH.</li> <li>• Teak surfing, dragging, or water skiing within 20 feet of a moving watercraft can be fatal.</li> </ul>

### ***Facts about CO***

- CO poisoning causes a significant number of boating deaths each year.
- Called the "silent killer", CO is an extremely toxic, colorless, odorless and tasteless gas.
- CO can harm or even kill you inside or outside your boat.
- CO can affect you whether you're underway, moored, or anchored.
- CO symptoms are similar to seasickness or alcohol intoxication.
- CO can make you sick in seconds. In high enough concentrations, even a few breaths can be fatal.
- Breathing CO blocks the ability of your blood to carry oxygen.
- The effects are cumulative, even low levels of exposure can result in injury or death.

### ***Factors That Increase the Effects of CO Poisoning***

- Age
- Smokers or people exposed to high concentrations of cigarette smoke
- Consumption of alcohol
- Lung disorders
- Heart problems
- Pregnancy

## Where and How CO Can Accumulate

### Stationary Conditions That Increase CO Accumulations Include:

- A. Using engine, generator, or other fuel burning device when boat is moored in a confined space.

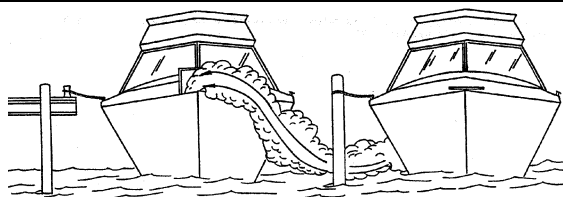
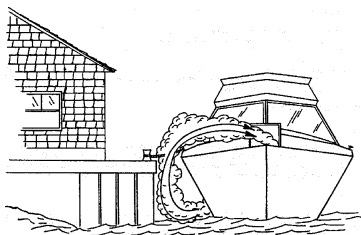

- B. Mooring too close to another boat that is using its engine, generator, or other fuel burning device.

#### To correct stationary situations A and/or B:

- **Close all** windows, portlights and hatches.
- If possible, move your boat away from source of CO.

### Running Conditions That Increase CO Accumulations Include:

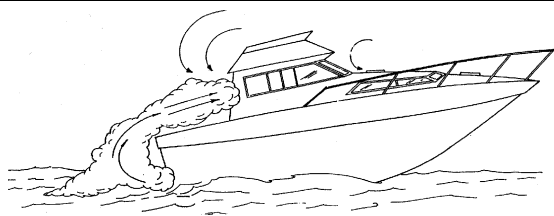

- C. Running boat with trim angle of bow too high.

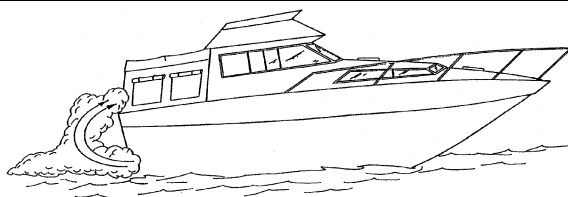

- D. Running boat without through ventilation (station wagon effect).

#### To correct running situations C and/or D:

- Trim bow down.
- **Open** windows and canvas.
- When possible, run boat so that prevailing winds help dissipate exhaust.

## How to Protect Yourself and Others From CO

- Know where and how CO may accumulate in and around your boat (see above).
- Maintain fresh air circulation throughout the boat at all times.
- Know where your engine and generator exhaust outlets are located and keep everyone away from these areas.
- **Never** sit on, or hang onto, the back deck or swim platform while the engine(s) are running.
- **Never** enter the areas under swim platforms where exhaust outlets are located.
- Although CO can be present without the smell of exhaust fumes, if exhaust fumes are detected on the boat, take immediate action to dissipate these fumes.
- Treat symptoms of seasickness as possible CO poisoning. Get the person into fresh air immediately. Seek medical attention—unless you're sure it's **not** CO.
- Install and maintain CO alarms inside your boat. **Do not** ignore any alarm. Replace alarms as recommended by the alarm manufacturer.
- Follow the checklists provided on the next page.
- Get a Vessel Safety Check.

For information on how to get a free VESSEL SAFETY CHECK, visit [www.vesselsafetycheck.org](http://www.vesselsafetycheck.org) or contact your local U.S. Coast Guard Auxiliary or United States Power Squadrons®.

- U.S. Coast Guard Auxiliary: 1-800-368-5647 or on the Internet at: <http://www.cgaux.org>
- U.S. Power Squadrons: 1-888-FOR-USPS (1-888-367-8777) or on the Internet at: <http://www.usps.org>

**Trip Checklist**

- Make sure you know where the exhaust outlets are located on your boat.
- Educate *all* passengers about the symptoms of CO poisoning and where CO may accumulate.
- When docked, or rafted with another boat, be aware of exhaust emissions from the other boat.
- Confirm that water flows from the exhaust outlet when the engines and generator are started.
- Listen for any change in exhaust sound, which could indicate an exhaust component failure.
- Test the operation of each CO alarm by pressing the test button.

**Monthly Checklist**

- Make sure *all* exhaust clamps are in place and secure.
- Look for exhaust leaking from exhaust system components. Signs include rust and/or black streaking, water leaks, or corroded or cracked fittings.
- Inspect rubber exhaust hoses for burned, cracked, or deteriorated sections. *All* rubber hoses should be pliable and free of kinks.

**Annual Checklist*****Have a Qualified Marine Technician:***

- Replace exhaust hoses if cracking, charring, or deterioration is found.
- Ensure that your engines and generators are properly tuned, and well maintained.
- Inspect each water pump impeller and the water pump housing. Replace if worn. Make sure cooling systems are in working condition.
- Inspect *all* metal exhaust parts for cracking, rusting, leaking, or loosening and check the cylinder head gasket, exhaust manifold, water injection elbow, and the threaded adapter nipple between the manifold and the elbow.
- Clean, inspect, and confirm proper operation of the generator cooling water anti-siphon valve (if equipped).

## Carbon Monoxide Alarm System

<b>⚠ DANGER!</b>	
	<b><i>CARBON MONOXIDE POISONING HAZARD!</i></b>
	<ul style="list-style-type: none"> <li>• The house battery switch <i>must</i> be in the <i>On</i> position for the CO Monitors to work.</li> </ul>

<b>NOTICE</b>
<p>The stereo memory and CO monitor(s) place a small, but constant drain on the battery. If your boat will be unattended for an extended amount of time, plug into shore power with the battery charger turned <i>On</i>, or disconnect the battery if shore power is <i>not</i> an option.</p>

- Your boat features a carbon monoxide (CO) alarm system.
- ***Do not*** disconnect the alarm system.
- Read and understand the manufacturer's instructions for your CO alarm system. If you did ***not*** receive an instruction manual, call (800) 383-0269 and one will be mailed to you.

If your boat is ***not*** equipped with a carbon monoxide alarm, consider purchasing one from your dealer or marine supply store.

### More Information

For more information about how you can prevent carbon monoxide poisoning on recreational boats and other ways to boat more safely, contact:

**United States Coast Guard**  
Office of Boating Safety (G-OPB-3)  
2100 Second Street SW  
Washington, DC 20593  
[www.uscgboating.org](http://www.uscgboating.org)  
1-800-368-5647

**National Marine Manufacturers Association (NMMA)**  
200 East Randolph Drive  
Suite 5100  
Chicago, IL 60601-9301  
[www.nmma.org](http://www.nmma.org)  
312-946-6200

**American Boat & Yacht Council, Inc. (ABYC)**  
3069 Solomon's Island Road  
Edgewater, MD 21037-1416  
[www.abycinc.org](http://www.abycinc.org)  
410-956-1050

For information on how to get a free VESSEL SAFETY CHECK, visit [www.vesselsafetycheck.org](http://www.vesselsafetycheck.org) or contact your local U.S. Coast Guard Auxiliary or United States Power Squadrons®.

- U.S. Coast Guard Auxiliary: 1-800-368-5647 or on the Internet at: <http://www.cgaux.org>
- U.S. Power Squadrons: 1-888-FOR-USPS (1-888-367-8777) or on the Internet at: <http://www.usps.org>

## Chapter 2: Locations

### Exterior Views

#### Hull Views

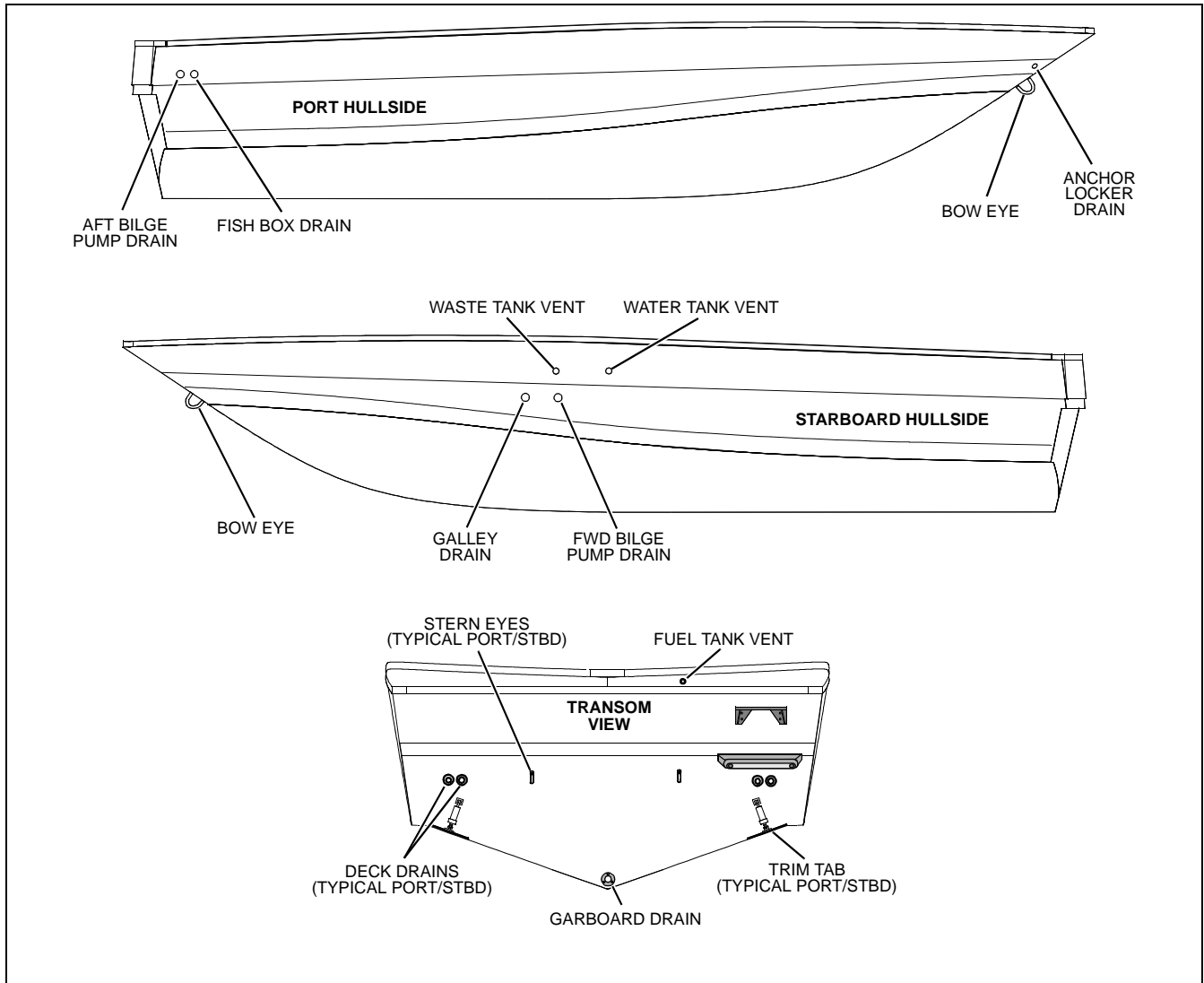

**Deck View**

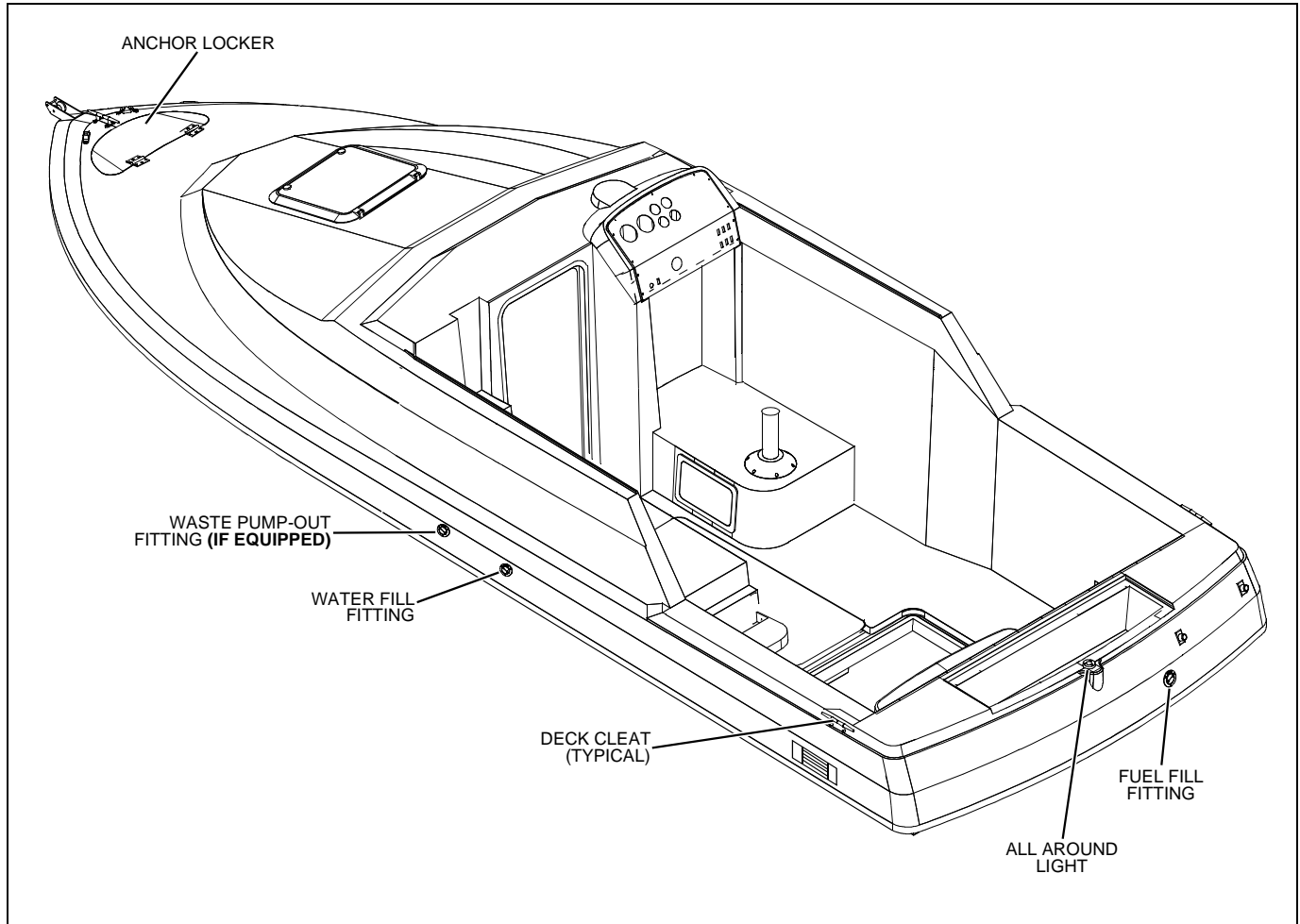



### Helm

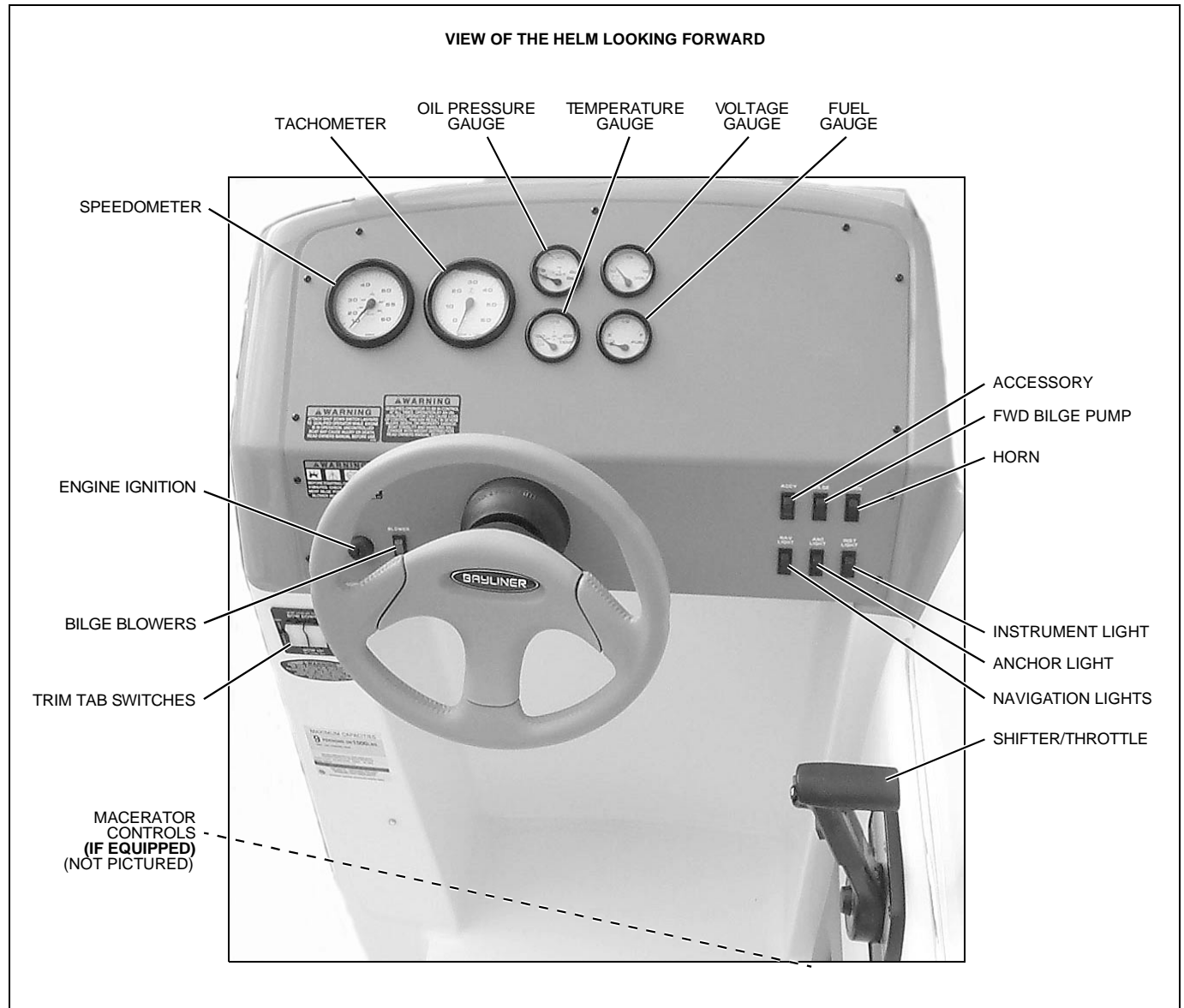

## Component Locations

**Bilge Pump - Aft:** In the engine compartment.

**Bilge Pump - Forward:** Under the cabin entry step.

**Carbon Monoxide Detector:** On the starboard aft dinette wall.

**DC Circuit Breakers:** At the helm, under the dash.

**Engine Circuit Breaker:** On the engine.

**Fuel Fill:** On the starboard aft deck above the swim step.

**Fuel Tank:** In the engine compartment forward of the engine.

**Macerator Underwater Discharge Seacock:** On the transom inside the engine room.

**Navigation Lights:** Red and green lights at the bow. White all-around light on the stern, or if equipped, on the hardtop.

**Waste Holding Tank:** Inside the port passenger seat storage compartment under the shelf.

**Water Fill:** On the port side deck trail.

**Water Pump:** Inside the port passenger seat storage compartment under the shelf, next to the water/holding tanks.

**Water Pump Switch:** Inside the cabin, at the galley, just below the galley countertop.

**Water Tank:** Inside the port passenger seat storage compartment under the shelf.

## Chapter 3: Propulsion & Related Systems

### Engine

The owner's packet contains detailed engine operation and maintenance manuals. Be sure to read and understand these manuals *before* starting or doing any maintenance on the engine.

### Engine Room Ventilation System

⚠ **WARNING!**



**FIRE/EXPLOSION HAZARD**

- Use of the blower system is *NOT A GUARANTEE* that explosive fumes have been removed.
- If you smell fuel, *DO NOT* start the engine and *DO NOT* turn On any electrical devices.
- If you smell fuel and the engine is already running, *shut Off* the engine and *turn Off all* electrical devices. Investigate *immediately*.
- *DO NOT* obstruct or modify the ventilation system.

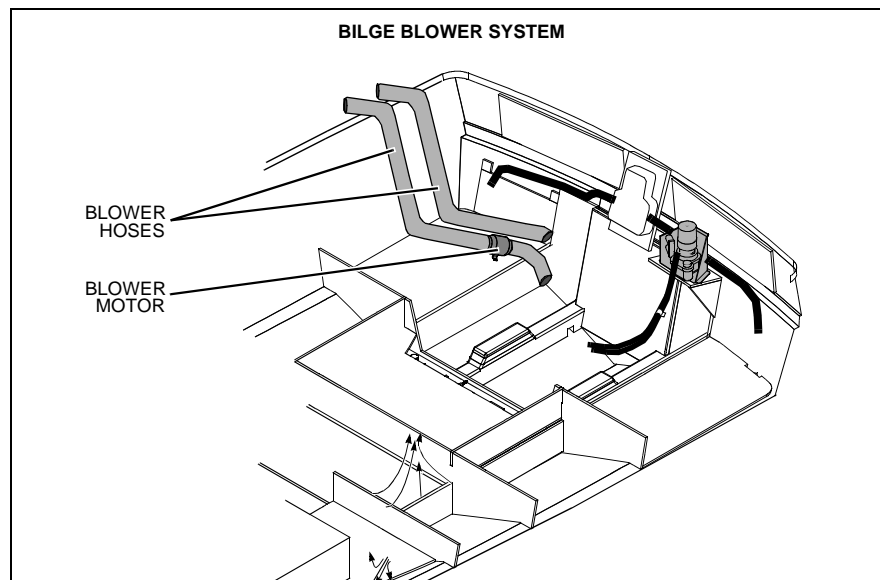

- The bilge blower removes explosive fuel fumes from the engine compartment.
- Fresh air is drawn into the compartment through the deck vents.
- The bilge blower switch is at the helm.
- If the boat is equipped with a generator, there is a second bilge blower switch on the main AC panel.

To make sure the engine compartment is ventilated with fresh air, run the bilge blower:

- For at least four minutes *before* starting the engine.
- During starting.
- Anytime your boat is running below cruising speed.

# Fuel System

**! WARNING!**

**! FIRE, EXPLOSION AND OPEN FLAME HAZARD!**

- It is very important that the fuel system be inspected thoroughly the first time it is filled and at each subsequent filling.
- The fueling instructions in the *Cruiser & Yacht Owner's Manual* and the fuel recommendations in the engine operation manual *must* be followed.

**! CAUTION**

Avoid the storage or handling of gear near the fuel lines, fittings and tank.

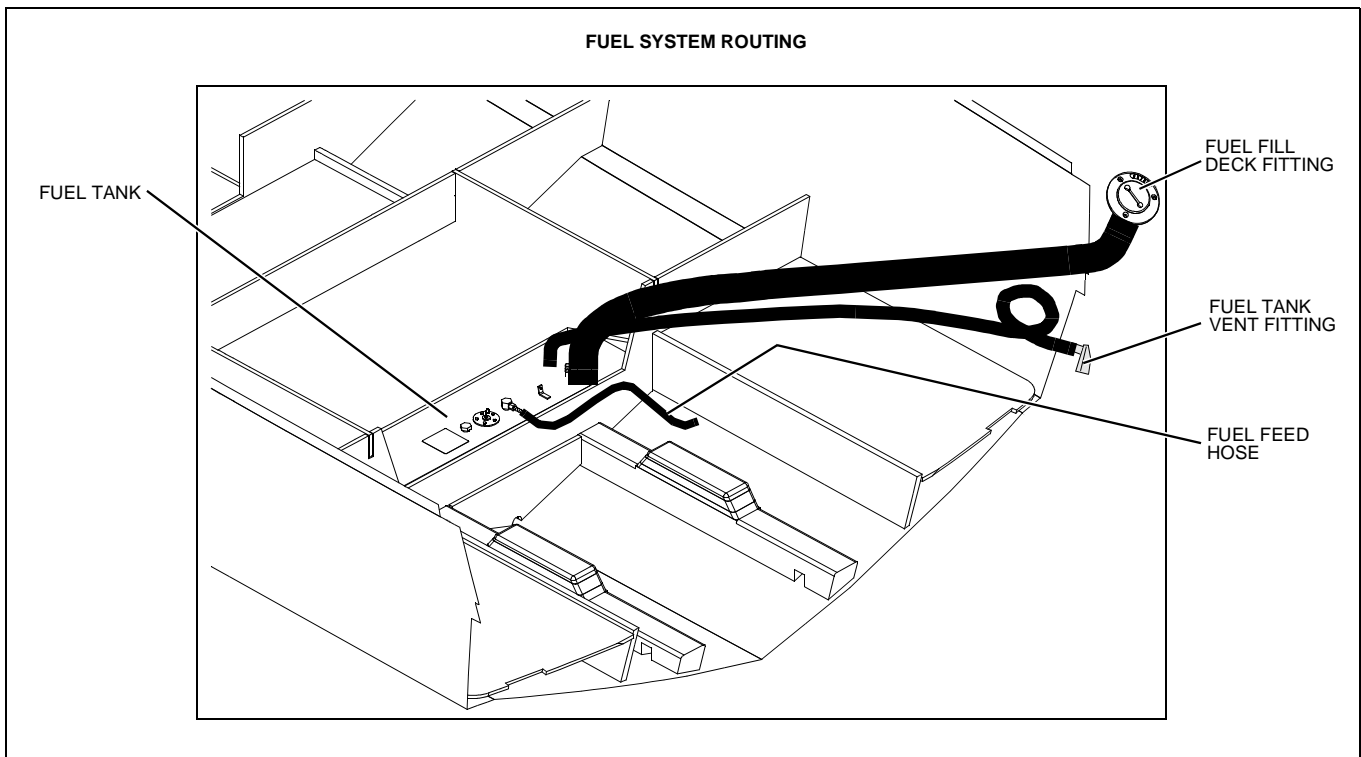

### **Fuel Fill and Vent**

- The fuel fill fitting is marked “GAS”.
- The fuel tank vent is located below the fuel fill.
- If you experience difficulty filling either fuel tank, see if the fuel fill hose or fuel tank vent hose is kinked or collapsed.
- If there are no visible signs of a problem, contact your local dealer.

### **Fuel Filters**

- The fuel pickup tube (located inside the fuel tank) is equipped with a fine mesh screen filter.
- In addition, when supplied by the engine manufacturer, a fuel filter is installed on the engine.
- Periodically replace the fuel filters to make sure they remain clean and free of debris.
- Consult with your selling dealer or local marina concerning fuel additives that help to prevent fungus or other buildup in your fuel tank.

### **Anti-siphon Valve**

#### **NOTICE**

- **If an engine running problem is diagnosed as fuel starvation, check the anti-siphon valve. If the valve is stuck or clogged, change or replace it while the engine is shut down.**
- **NEVER run the engine with the anti-siphon valve removed, except in an emergency.**

- Your boat is equipped with an anti-siphon valve, which is an integral part of fuel system.
- The valve is located at the point where the fuel feed line attaches to the fuel tank.
- The valve is spring loaded and is opened by fuel pump vacuum.
- This valve *will* prevent fuel from siphoning from the tank in the event of a fuel line rupture.

## Quick Oil Drain System

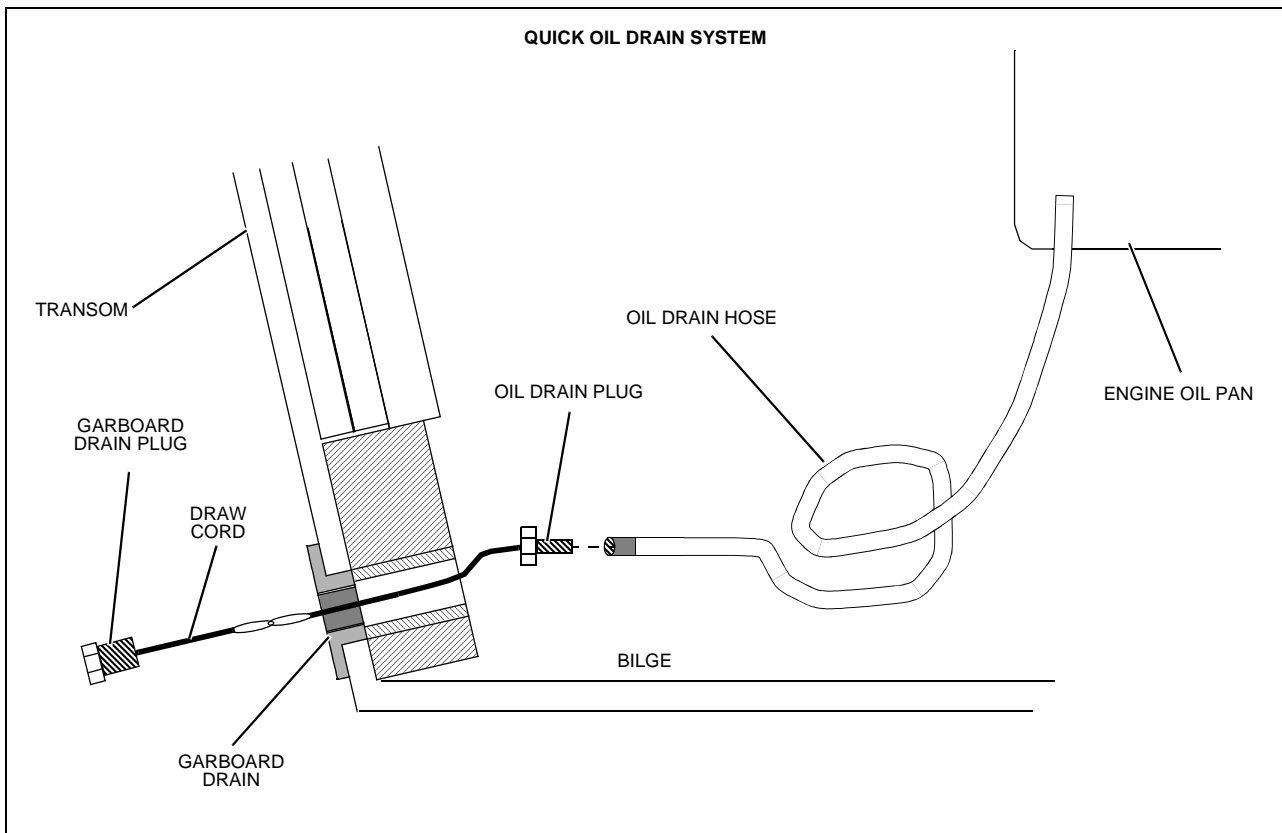

### *To drain the engine oil:*

1. Remove the boat from the water.
2. Unscrew the garboard drain plug.
3. Pull the draw cord until the oil drain plug and the oil drain hose slide out of the garboard drain.
4. Place the end of the oil drain hose into a suitable container.
5. Unscrew the oil drain plug and drain the engine oil.
6. Replace the oil drain plug.
7. Push the drain hose back into the bilge.
8. Replace the garboard drain plug.

***Always dispose of waste oil in accordance with local regulations.***

## Chapter 4: Controls

---

### Steering

- This boat features a power assisted rack-and-pinion steering system.
- Check the fluid level in the power steering reservoir *every time* you use your boat.
- Boat steering is *not* self-centering.

### Shift/Throttle

 <b>WARNING!</b>
<b><i>LOSS OF CONTROL HAZARD!</i></b>
<b>Improper maintenance of shift/throttle hardware may cause a sudden loss of control!</b>

- Carefully read and understand *all* of the information about the shift/throttle in the *Cruiser & Yacht Owner's Manual*.
- Also, read and understand the shifter/throttle and engine manuals included in your owner's packet.

### Power Trim and Tilt

- The stern drive on your boat is equipped with power trim and tilt.
- Trim and tilt instructions are provided in the engine operation manual and the shifter/throttle manual is included in your owner's packet.

## Trim Tabs (If Equipped)

⚠ **WARNING!**

***LOSS OF CONTROL HAZARD!***

**Improper use of trim tabs *will* cause loss of control!**

- ***Do not*** allow anyone unfamiliar with trim tabs to use them.
- ***Do not*** use trim tabs in a following sea as they ***will*** cause broaching or other unsafe handling characteristics.
- ***Do not*** use trim tabs to compensate for excessive unequal weight distribution.

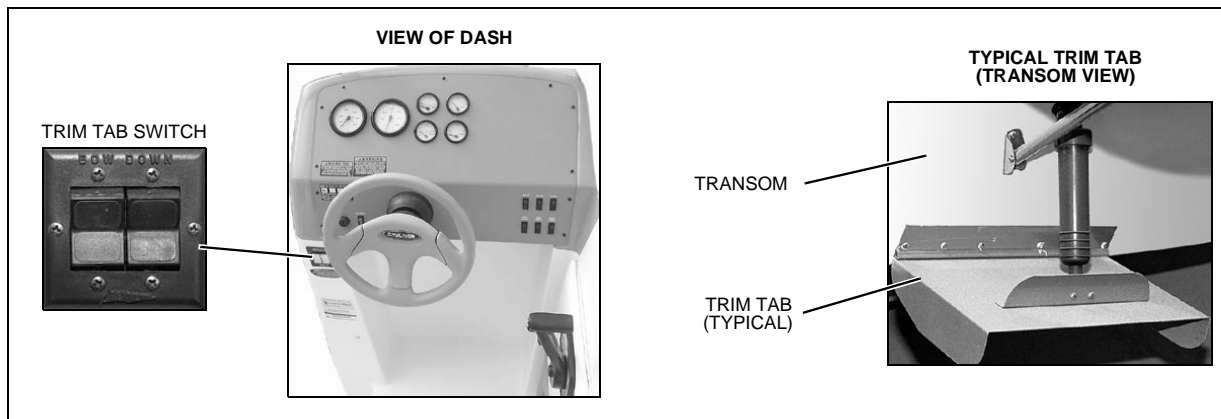

- The trim tabs may be used to help keep your boat level at cruising speeds.
- The trim tabs are controlled by two rocker switches at the helm.
- ***Before*** using the trim tabs read and understand the trim tab operation manual included in your boat's owner's packet.

Observe the following:

1. Once cruising speed is reached, the port or starboard trim switch may be used (one at a time) to level the boat.
2. Perform trim tab adjustment with several short touches to the switch rather than one long one.
3. After each short touch allow several seconds for the hull to react.
4. The trim tab hydraulic fluid reservoir is located in the engine compartment. The fluid level ***must*** be checked periodically (*at least once a year*) and refilled as necessary.



## Chapter 5: Plumbing

---

### Drain Systems

#### *Deck Drains*

Water on the deck is drained overboard through the deck drains. Keep the deck drains free of debris.

#### *Galley Sink Drain*

The galley sink is above the water-line and is gravity drained overboard.

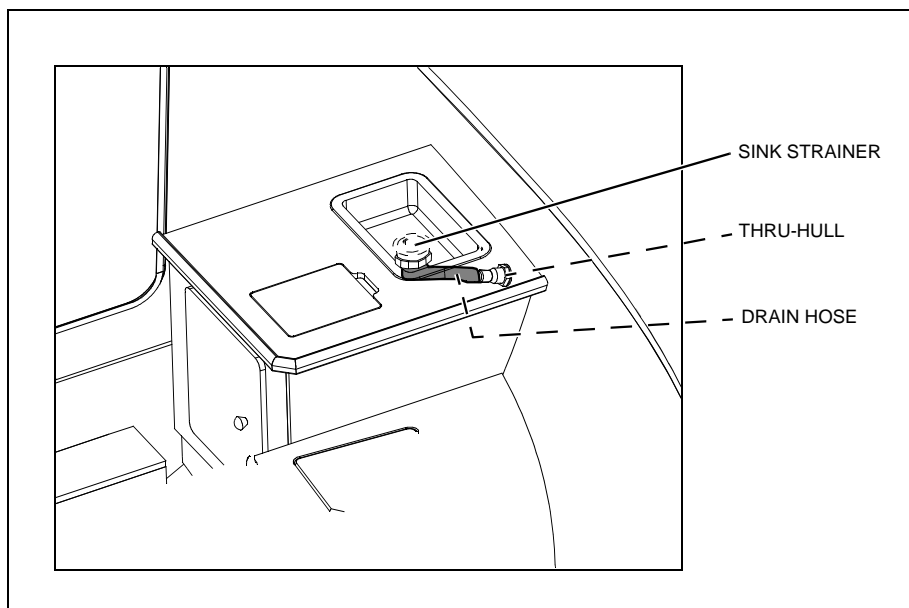

## Bilge Pumps

### NOTICE

Discharge of oil, oil waste or fuel into navigable waters is prohibited by law. Violators are subject to legal action by the local authorities.

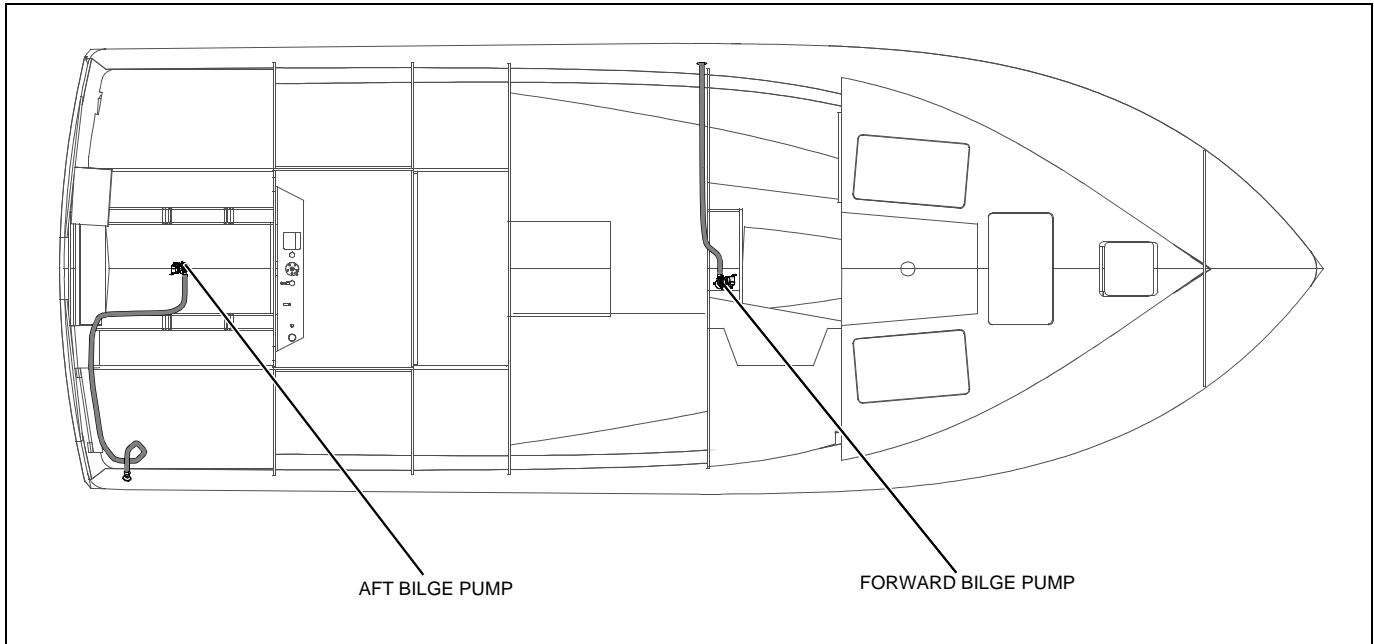

- Your boat is equipped with two automatic impeller-type bilge pumps which are used to pump water out of the bilge.
- The bilge pumps are controlled by automatic bilge pump float switches (autofloat switches) and/or switches at the helm.
- The bilge pumps are wired directly to the battery so they *will* normally function even when the boat is completely shut down and left unattended.

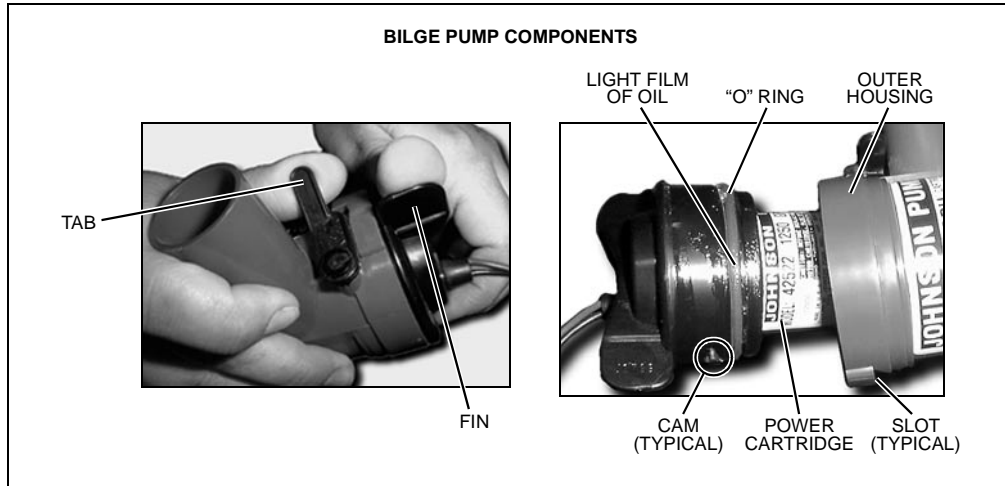
**Bilge Pump Testing**

- The bilge pumps are critical to the safety of your boat.
- Check the bilge pumps often to make sure they are working.

Test each pump often as follows:

1. Turn **On** the bilge pump switch at the helm.
2. Any water in the bilge should pump overboard.

- If the pump motor is running but **not** pumping inspect the discharge hose for a kink or collapsed area.
- If **no** problems are found, check the bilge pump housing for clogging debris as follows:

1. Remove the power cartridge:
  - a. Lift the tab while rotating the fins counter-clockwise.
  - b. Lift out the power cartridge.
  - c. Clear the outer housing of debris.
2. Reinstall the power cartridge:
  - a. Make sure the "O" ring is properly seated.
  - b. Coat the "O" ring with a light film of vegetable or mineral oil.
  - c. Align the cams on either side of the power cartridge with the two slots on the outer housing
  - d. Press the power cartridge into the housing while twisting clockwise.
3. Check the reinstallation by trying to twist the fins counter-clockwise without lifting the tab; the cartridge should stay in place.

### Autofloat Switches

- The automatic bilge pumps use electromagnetic float switches (autofloat) to turn **On** the pumps whenever water rises above a preset level in the bilge.
- One autofloat switch is mounted next to each automatic bilge pump.
- The autofloat switches are wired directly to the battery and **will** normally function even when the boat is completely shut down and left unattended.

Test the autofloat switches often as follows:

1. Push the float switch test button up to turn **On** the bilge pump.
  - If the pump does **not** turn **On**, check the inline fuse.
  - If the fuse is good but the switch still does **not** work, it may mean the switch is bad or possibly the battery is low.
2. Push test button **all** the way **down** to return the float switch to auto mode.

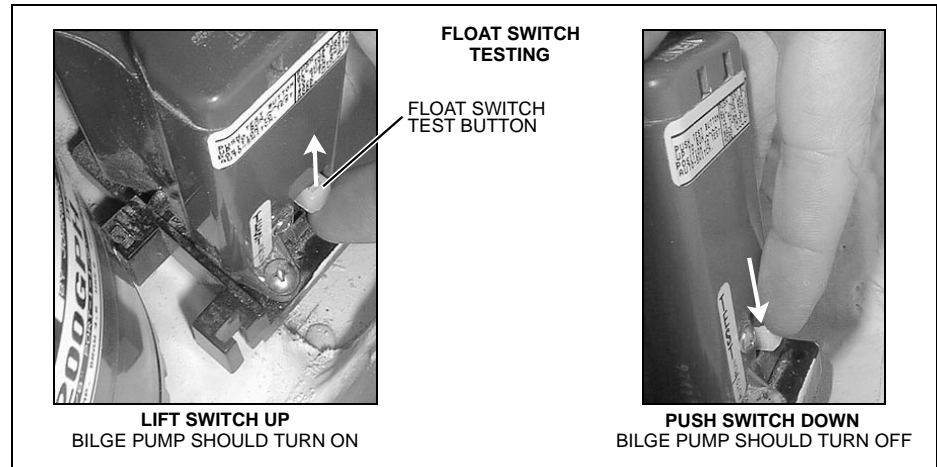

## CAUTION!

When the test is completed on each float switch, you **MUST** push the test button *all the way down* to the auto position to return the switch to auto mode!

## Seawater Systems

### Seacocks



### CAUTION!

#### SYSTEM DAMAGE HAZARD!

- **Before using a seawater intake system, make sure that the system's seacock is in the *Open* position before the system is started and keep the seacock *Open* until the system is shut *Off*.**
- **Close the seacocks whenever the systems *will not* be used for long periods of time.**

A seacock is a valve, controlled by a 90° lever, used to manage the intake of seawater through the hull and below the water line. Seacocks are typically used on your boat in the following seawater intake systems:

- Marine head (toilet)
- Air conditioning system (if equipped)

**Before** using any of these systems, make sure that the system's seacock is **Open** and remains **Open** until the system is shut **Off**.

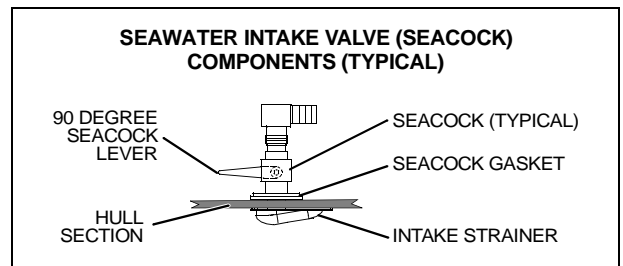

### Seawater Strainers

- Seawater strainers are used in water pickup systems to filter incoming seawater.
- A seawater strainer is located near each system's seacock.
- Check the strainers for leaks and/or debris **every time you use your boat**.
- If debris is found, clean the seawater strainer as follows:



### CAUTION!

#### FLOODING HAZARD!

- **The seacock that sends seawater to the strainer *must* be *Closed* before disassembling the seawater strainer to prevent the boat from taking on water through the seawater strainer assembly.**
- **Keep the seacock *Closed* until the seawater strainer is completely reassembled.**

#### SYSTEM DAMAGE HAZARD!

- **After reassembling the seawater strainer, make sure that the seacock valve is *Open* before using the component/system.**

1. Turn **Off** the component or system that the strainer is connected to.
2. **Close** the seacock that sends seawater to the strainer you are about to clean. The seacock **must** remain **Closed** until the strainer is completely reassembled.
3. Take apart the seawater strainer.
4. Remove the debris.
5. Flush the strainer with water.
6. Reassemble the seawater strainer.
7. **Open** the seacock and check for leaks around the strainer.
8. If no leaks are found, you may use the component or system.

## Freshwater System



### WARNING!

- **Only** use safe drinking (potable) water in your boat's freshwater system.
- **Only** use a sanitary drinking water hose to fill the water tank or connect to city water.
- **Never** use a common garden hose for drinking water.

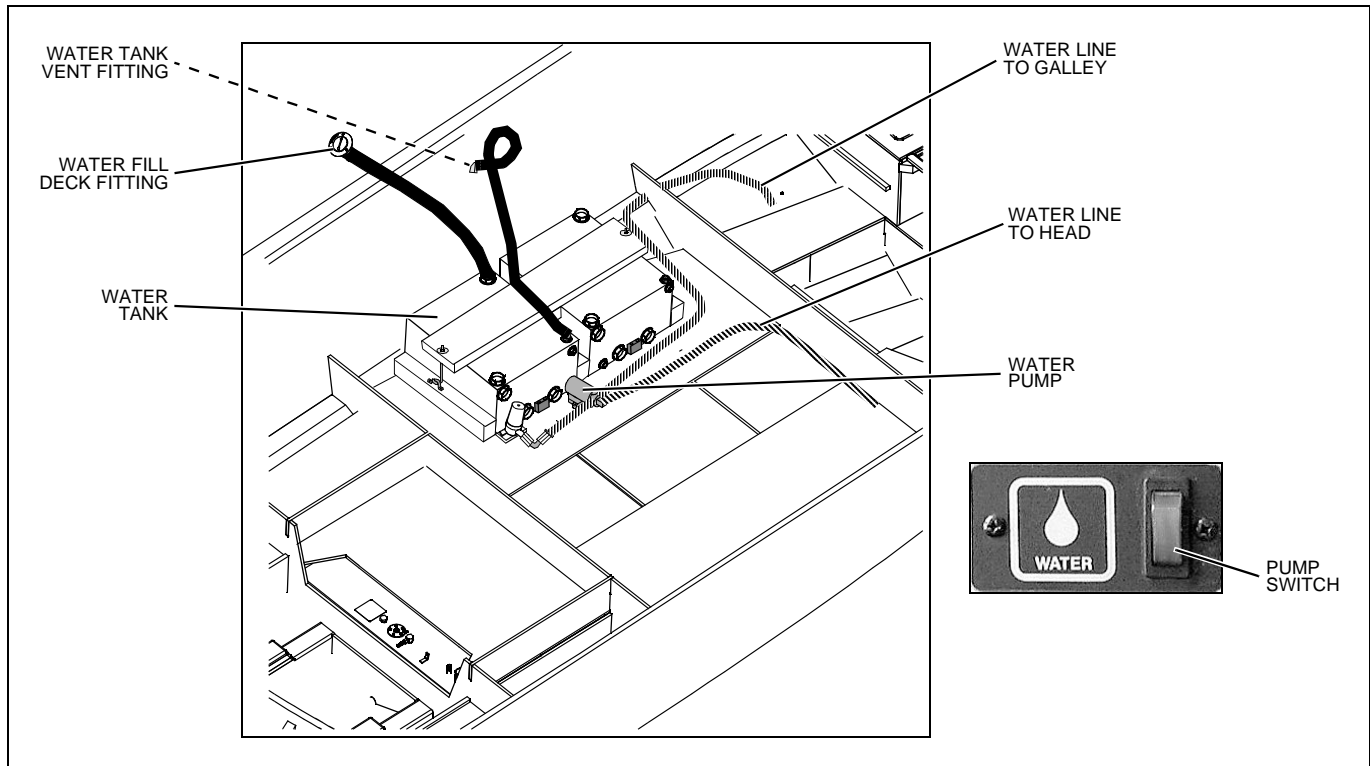

- Read the *Freshwater System* section in the *Cruiser & Yacht Owner's Manual*.
- Your boat is equipped with a pressure type (demand) freshwater (potable) system.
- This system can be pressurized by turning **On** the water pump.
- See the *Component Location* section of this *Supplement* for the location of the water pump switch.

Observe the following about the freshwater system:

- Turn **Off** the water pump when the boat is not in use or the water tank is empty.
- Inspect and clean the water filter often (located on the water pump).
- When your boat is to be left unattended for long periods of time, pump the water tank dry to prevent stored water from becoming stagnant and distasteful.
- To winterize the freshwater system, pump the water tank dry and drain the system by opening the water filter.
- If the freshwater system needs to be disinfected, ask your dealer about treatments available for your boat's system.

## Marine Head with Holding Tank (If Equipped)

### NOTICE

Check with local authorities for regulations regarding the legal use of marine head systems.

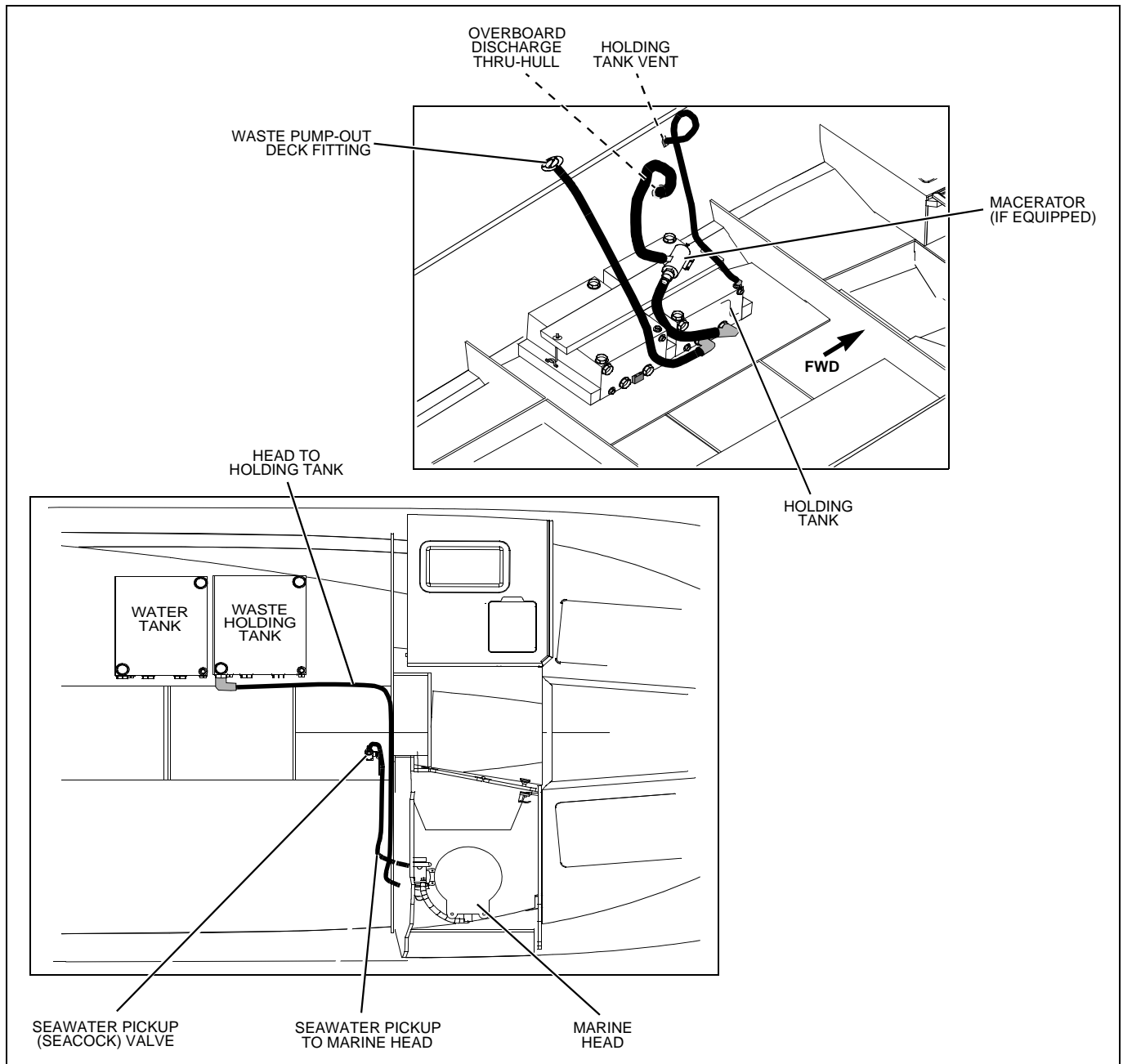

- Read the marine head operation and maintenance manual (included in your boat's owner's packet).
- The holding tank is plumbed to a waste fitting on the deck for dockside pump-out.
- Check the content level of the holding tank by looking at the side of the tank.
- Empty the holding tank at every opportunity.

**Operating the manual flush marine head:**

1. **Open** the head's seawater intake valve (seacock).
2. **Before** using the head, pump enough water into the bowl to wet the sides.
3. After use, pump until the bowl is thoroughly cleaned. Continue pumping a few more times to clean the lines.
4. If excess waste causes the water to rise in the bowl, stop pumping until the water recedes.

**Winterizing The Marine Head**

1. Shut **Off** the seawater intake seacock.
2. Pump the water out of the bowl until the bowl is dry.
3. Remove the drain plug in the base and pump again to remove **all** of the water.
- **Do not** fill the bowl with anti-freeze.
- **Close** the intake seacock while the boat is underway or whenever the boat is left moored in the water.

**Macerator (If Equipped)****NOTICE**

**Check with local authorities for regulations regarding the legal use of marine head systems.**

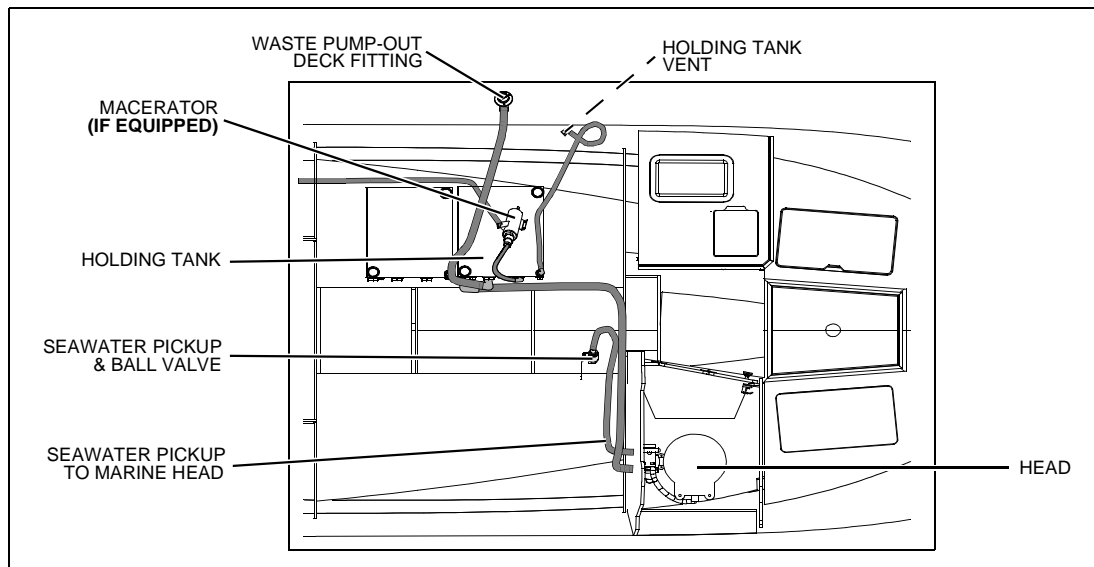

To use the macerator to pump waste directly into the water (where regulations permit):

1. **Open** the underwater discharge seacock.
2. Press both macerator switches at the same time to run the pump. **Do not** continue running the macerator if the waste holding tank is empty.
3. **Close** the underwater discharge seacock when you are done pumping.



## Chapter 6: Deck Equipment

---

### Cleats and Tow Eyes



#### **WARNING!**

***PERSONAL INJURY and /or PRODUCT or PROPERTY DAMAGE HAZARD!***

- ***NEVER*** lift the boat using the bow and stern eyes or the cleats.

Carefully read the section on towing in the *Cruiser & Yacht Owner's Manual* **before**:

- Towing anything behind the boat.
- Being towed by another vessel.

## Chapter 7: Entertainment Systems

---

### Audio System

#### **NOTICE**

**AM radio reception may be impaired anytime the engine or generator is running.**

## Chapter 8: Convertible Seats, Beds, & Tables

### Sleeper Seat Adjustment

Your boat may be equipped with adjustable sleeper seats. These seats can be adjusted fore and aft in the upright position. The seat bottoms of these models also adjust into backrests while the seats are in the lounge position.

#### Fore-aft positions:

To slide a seat forward or backward:

1. Lift up on the front edge of the seat bottom (A).
2. Move the seat forward until the locking mechanism engages in one of the three different positions.
3. Lift the aft seat at point (B) and slide the aft seat towards the forward seat.

#### Lounge positions:

To put the seat into the lounge position:

1. Lift up on the front edge of the seat (A) and pull the seat all the way forward.
2. Lift the aft seat at (B) and pull the aft seat away from the forward seat until the seat is laid out flat.
3. Lift up on the forward or aft seat bottom at point (C) until the seat bottom drops into the locked position.

To lower the seat bottom:

1. Lift the seat at points (C) and (D) at the same time.
2. Drop the seat bottom flat while holding the seat up at point (D).

To return the seat to the operating position:

1. Lift the seat back at point (E).
2. Push the seat bottom toward the center of the seat until it locks into place.

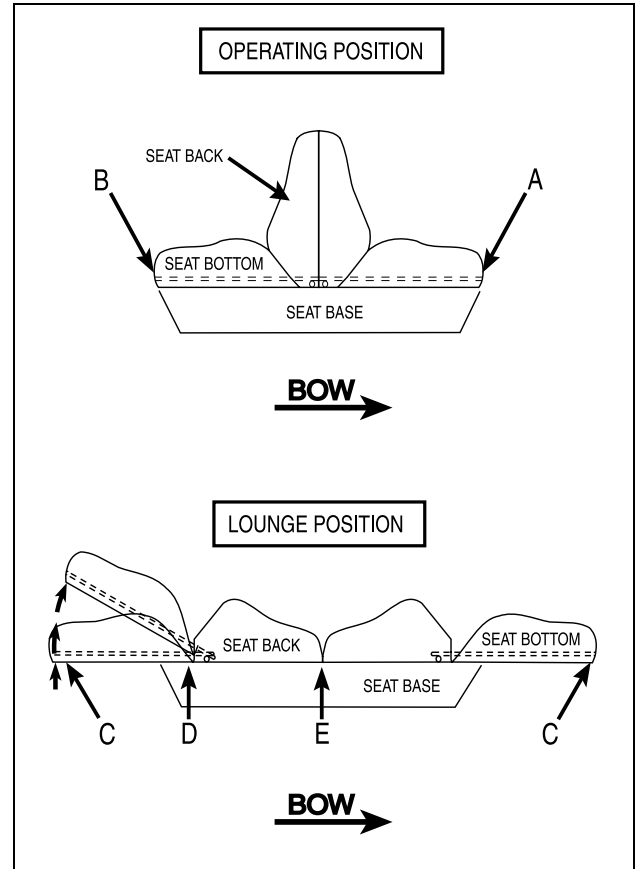

## Dinette/V-Berth

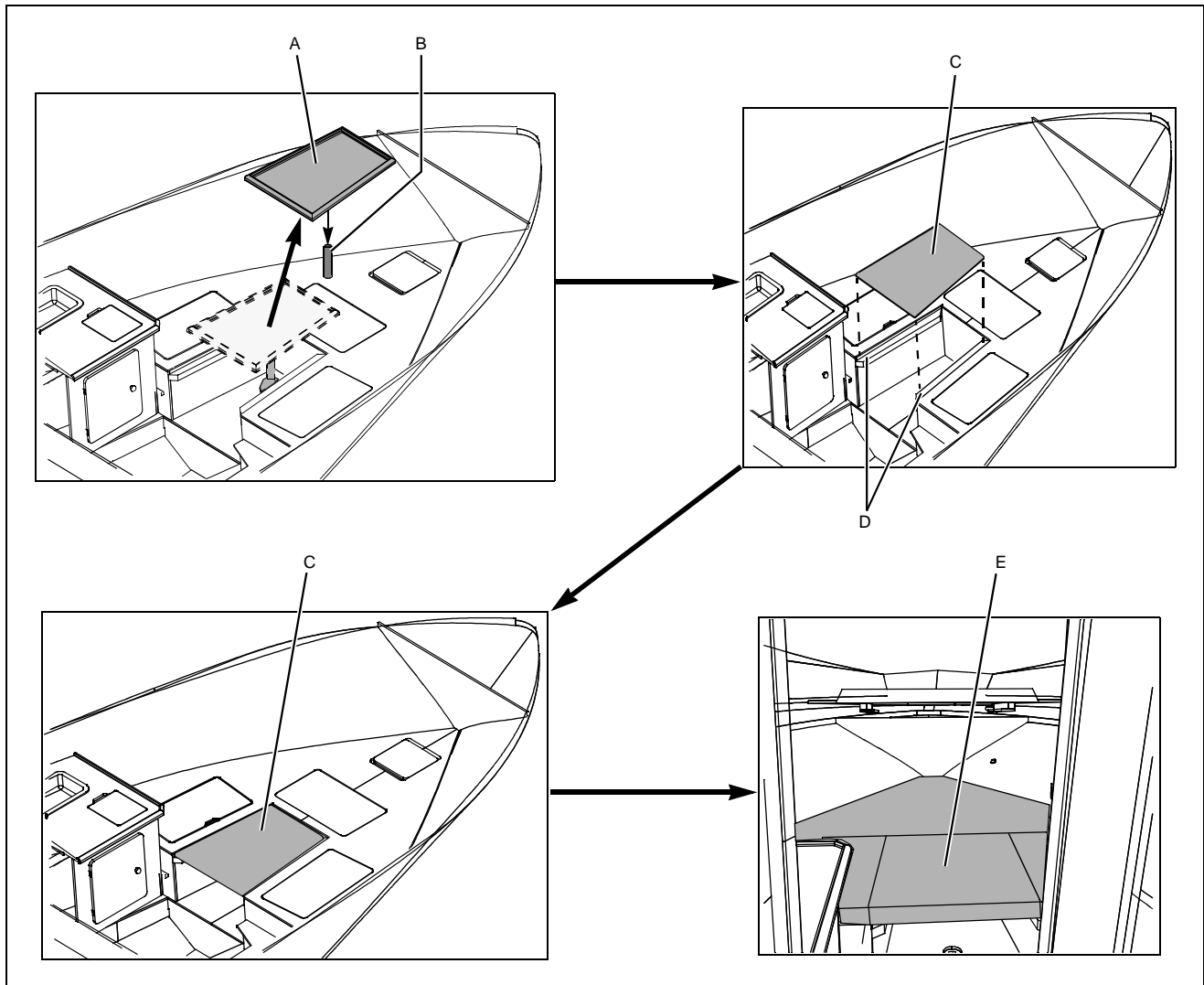

The dinette table can be removed and the dinette area can be converted into a berth.

1. Lift the table (A) and remove the table leg (B).
2. Place the filler board (C) so that it fits securely on the edge lips (D) at the front of the dinette seats.
3. Place the filler cushion (E) on top of the filler board (C).

## Chapter 9: Lights

---

### Care and Maintenance

All of the lights installed on your boat are of top quality, but you should be aware that failure may periodically occur for a variety of reasons:

1. There may be a blown fuse - *replace the fuse.*
2. The bulb may be burned out - *carry spare bulbs for replacement.*
3. A wire may be damaged or may have come loose - *repair as required.*
4. The bulb base may be corroded - *clean the base and coat it with non-conductive electrical lubricant.*

### Navigation Lights

 <b>CAUTION!</b>
<b>Avoid the storage of gear where it would block navigation lights from view.</b>

Read and understand the navigation light section of *Cruiser & Yacht Owner's Manual*.



### Interior & Exterior Lights

 <b>CAUTION!</b>
<ul style="list-style-type: none"><li>• <b>Be conservative in the use of battery power.</b></li><li>• <b>Prolonged use of cabin interior lights (overnight) will result in a drained battery.</b></li></ul>

- The lights are powered by the boat's 12-volt DC system.
- Some individual lights also have a switch on the light.





## Chapter 10: Electrical System

**DANGER!**





**EXTREME FIRE, SHOCK & EXPLOSION HAZARD!**

- To minimize the risks of fire and explosion, *NEVER* install knife switches or other arcing devices in the fuel compartments.
- *NEVER* substitute automotive parts for marine parts. Electrical, ignition and fuel system parts were designed and manufactured to comply with rules and regulations that minimize risks of fire and explosion.
- *DO NOT* modify the electrical systems or relevant drawings.
- Have qualified personnel install batteries and/or perform electrical system maintenance.

**WARNING!**





**FIRE & EXPLOSION HAZARD!**

- Fuel fumes are heavier than air and *will* collect in the bilge areas where they can be accidentally ignited.
- Visually and by smell (sniff test), check the engine and fuel compartments for fumes or accumulation of fuel.
- *ALWAYS* run the bilge blowers for at least four minutes *before* turning on electrical devices, starting the engine, or electrical system maintenance.
- Minimize the danger of fire and explosion by *not* exposing the batteries to open flame or sparks. *NEVER* smoke anywhere near the batteries.

**CAUTION!**

**SHOCK & ELECTRICAL SYSTEM DAMAGE HAZARD!**

*NEVER* disconnect the battery cables while the engine is running since it can cause damage to your boat's electrical system components.

### NOTICE

Electrical connections are prone to corrosion. To reduce corrosion caused electrical problems, keep *all* electrical connections clean and apply a spray-on protectant that is designed to protect connections from corrosion.

## 12-Volt DC System

### **Batteries**

The batteries supply electricity for lights, accessories, engine and generator (if equipped) starting.

The Electrical section of Chapter 8, in the *Cruiser & Yacht Owner's Manual*, provides battery, care and maintenance instructions.

### **Fuses and Circuit Breakers**

- Fuses and circuit breakers for engines and main accessory power are on the DC main distribution panel.
- Some equipment may have secondary fuse protection at the unit, or at the batteries.
- Electronics power is provided at the helm station.

### **Alternator**

The engine alternator *will* keep the batteries properly charged when running at cruising speeds.

### **12-Volt Accessory Outlet**



## **CAUTION!**

***DO NOT* use the 12-volt accessory outlet with a cigarette or cigar lighter. High temperatures may melt the outlet.**

- Your boat is equipped with a 12-volt accessory outlet at the helm.
- The outlet can be used with any 12-volt device which draws 15 amps or less.
- The 12-volt accessory outlet is protected by 15 amp circuit breakers on the main circuit breaker panel.

# Electrical Routings

## Hull Electrical Harness

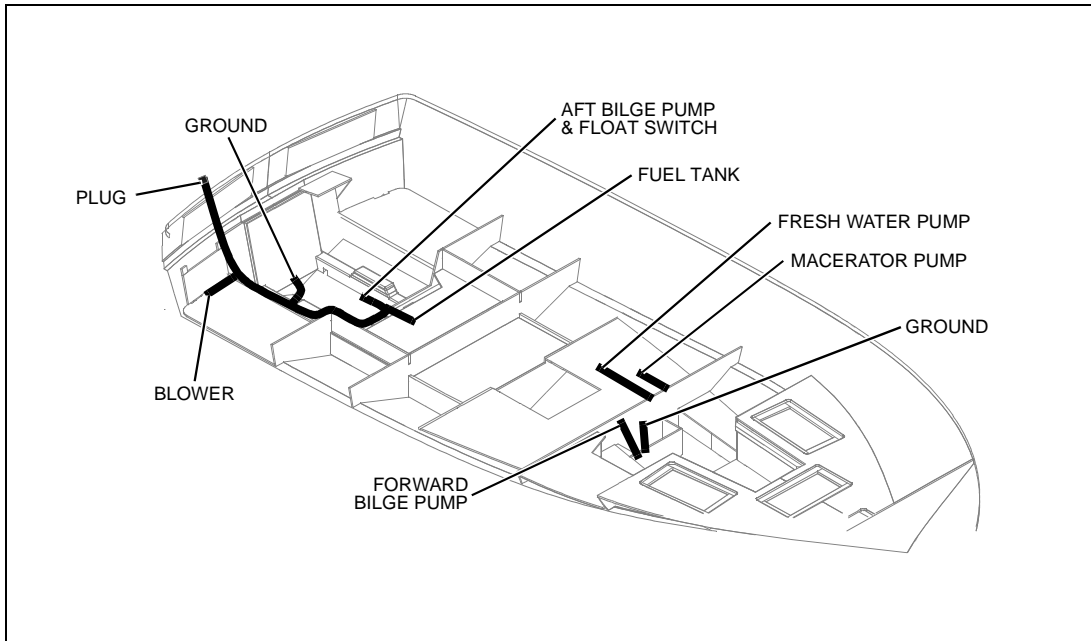

## Deck Electrical Harness

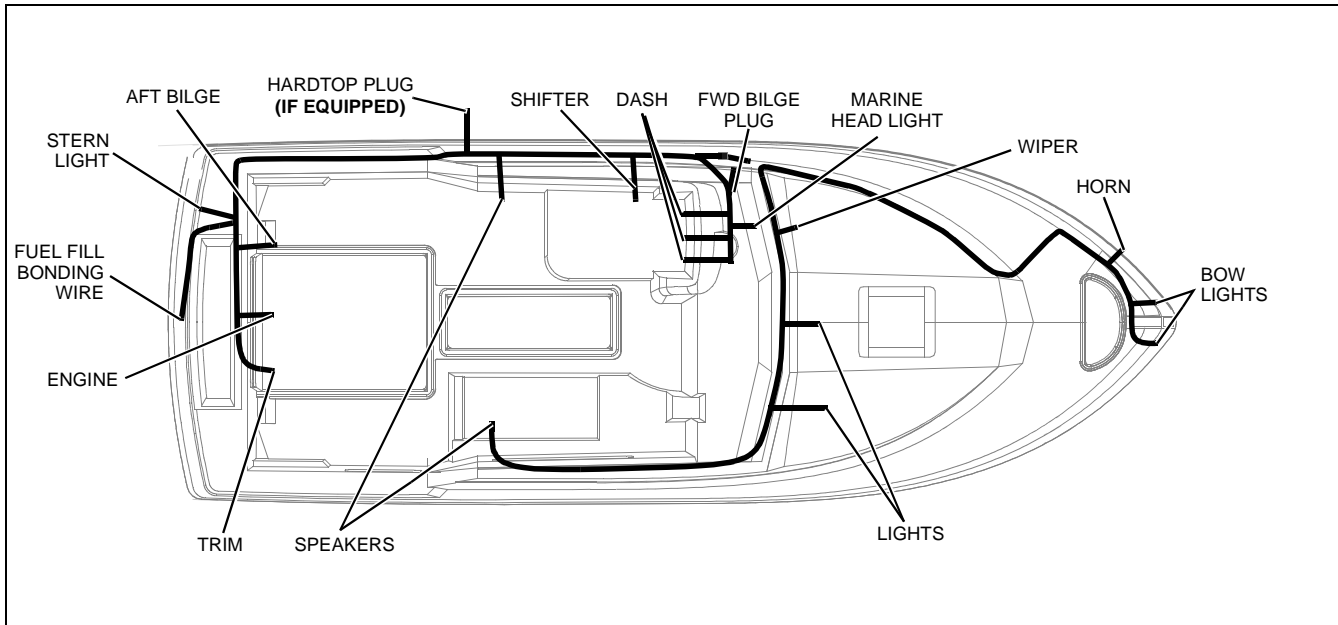



### Hardtop Harness (If Equipped)

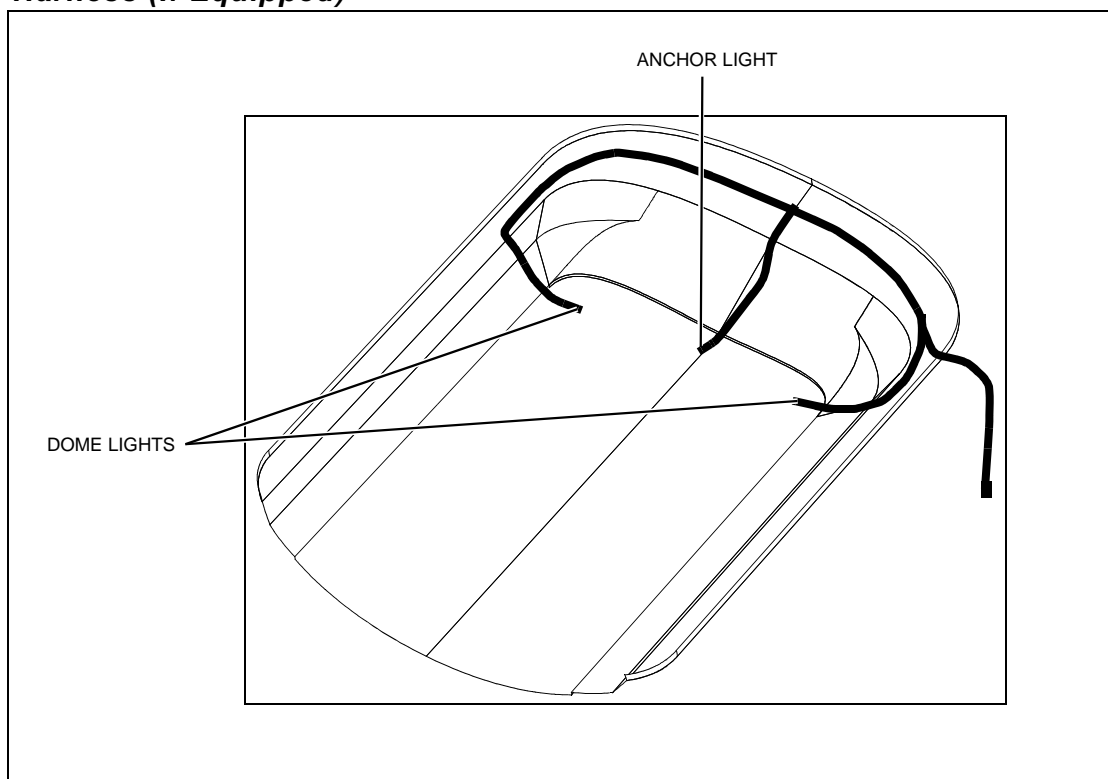

# Wire Diagram

## Engine Electrical System

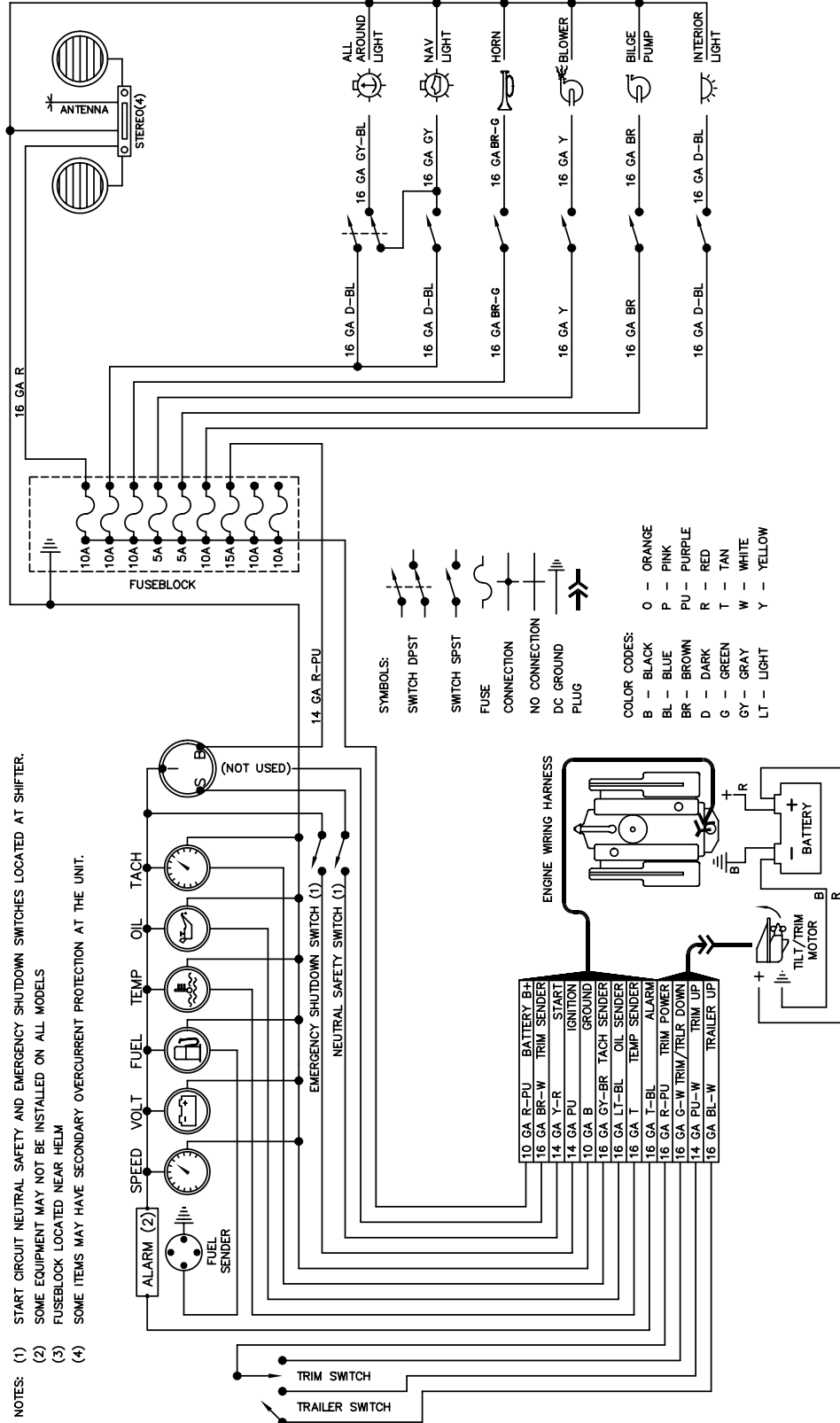

## Important Records

---

### Selling Dealer

\_\_\_\_\_  
Name Of Dealership

\_\_\_\_\_  
Address

\_\_\_\_\_  
Phone/FAX/E-mail

\_\_\_\_\_  
Sales Manager

\_\_\_\_\_  
Service Manager

### Engine

\_\_\_\_\_  
Manufacturer

\_\_\_\_\_  
Model Name/Number

\_\_\_\_\_  
Engine Serial Number

\_\_\_\_\_  
Oil Type/SAE

\_\_\_\_\_  
Quarts per Engine

\_\_\_\_\_  
Filter Type

### Propeller

\_\_\_\_\_  
Manufacturer

\_\_\_\_\_  
Pitch

\_\_\_\_\_  
Model Number

### Key Numbers

\_\_\_\_\_  
Ignition

\_\_\_\_\_  
Other

### Electronics

\_\_\_\_\_  
Manufacturer

\_\_\_\_\_  
Model Name/Number

\_\_\_\_\_  
Serial Number

\_\_\_\_\_  
Manufacturer

\_\_\_\_\_  
Model Name/Number

\_\_\_\_\_  
Serial Number

\_\_\_\_\_  
Manufacturer

\_\_\_\_\_  
Model Name/Number

\_\_\_\_\_  
Serial Number

\_\_\_\_\_  
Manufacturer

\_\_\_\_\_  
Model Name/Number

\_\_\_\_\_  
Serial Number

# Float Plan

Before going boating, fill out a copy of this float plan (or similar) and leave it with a *reliable* person whom you can depend on to contact the Coast Guard or other rescue organization, if you do not return as scheduled.

## Description of Boat

Registration/Documentation Number		
Length	Make	Type
Hull Color		Trim Color
Fuel Capacity	Engine Type	Number of Engines
Distinguishing Features		
Distinguishing Features		

## Operator of Boat

Full Name		
Male or Female	Age	Health
Address		
Address		
Phone/FAX/E-mail		
Operator's Experience		

## Persons on Board

Full Name		
Age	Health	Phone Number
Full Name		
Age	Health	Phone Number
Full Name		
Age	Health	Phone Number
Full Name		
Age	Health	Phone Number
Full Name		
Age	Health	Phone Number
Full Name		
Age	Health	Phone Number

## Survival Equipment

Marine Radio (Yes/No)	Type	Frequencies
Number of PFDs	Flares (Yes/No)	Mirror (yes or no)
Smoke Signals (Yes/No)	Flashlight (Yes/No)	Food (Yes/No)
Water (Yes/No)	Anchor (Yes/No)	Raft/Dinghy (Yes/No)
Paddles (Yes/No)	EPIRB (Yes/No)	Other
Other	Other	Other

## Vehicle Description

Make	Model
Color	License Number
Where is the Vehicle Parked?	

## Trip Expectations

Departing From	
Departure Date	Departure Time
Stopover 1	
Arrive No Later Than: Date	Arrive No Later Than: Time
Stopover 2	
Arrive No Later Than: Date	Arrive No Later Than: Time
Stopover 3	
Arrive No Later Than: Date	Arrive No Later Than: Time
Stopover 4	
Arrive No Later Than: Date	Arrive No Later Than: Time
Stopover 5	
Arrive No Later Than: Date	Arrive No Later Than: Time
Stopover 6	
Arrive No Later Than: Date	Arrive No Later Than: Time
Final Destination Port (If Different Than Home Port)	
Arrive No Later Than: Date	Arrive No Later Than: Time

**If not returned by the date and time listed above, call the Coast Guard or other local authority.**

Coast Guard Phone Number

Local Authority Phone Number





**Part Number 1717029**

**Bayliner • P.O. Box 9029 • Everett, WA 98206 • 360-435-5571**