

SKI CHALLENGER

*The International
World Class
Ski Leader*



1990 Owner's Manual



Welcome Aboard

This manual has been prepared to assist you in the operation and care of your Ski Challenger. Please read through it completely, as familiarization with its contents can contribute to the more effective operation of your boat.

Your Ski Challenger is part of a carefully engineered tournament ski package. It has been paired with a motor and trailer designed to provide optimum performance and utility. Please be aware that any changes you might make to this boat, motor and trailer combination may result in handling and performance qualities that differ from those experienced with the original package.

Your boat's mechanical and electrical systems were designed to meet safety standards in effect at the time the boat was constructed. Some of these standards were mandated by Federal law, others are considered industry norms. All of them were designed to insure your safety, and the safety of other people, vessels and property around you. To maintain the integrity and safety of your boat, only qualified people should perform maintenance on, or in any way modify, the steering system, engine control system, fuel system or electrical system. Failure to maintain these systems as designed could violate Federal

law, and could expose you and other people to the danger of bodily injury or accidental death. We recommend that you follow the instructions provided in this handbook, in the engine owner's manual, and in the accessory instruction sheets included with your boat, motor and trailer package. We also recommend that you perform the following steps:

1. Make certain that you receive a full explanation of all systems from the dealer before taking delivery of your boat.
2. Read this manual thoroughly, paying particular attention to the subjects of **fueling, checking for fumes, starting, carbon monoxide, loading limits, recommendations for safety, and warranty.**
3. Practice—all members of the family should be familiar with the operation and systems of your boat.
4. Participate in a safe boating course. Call the local office of the United States Power Squadrons or the United States Coast Guard Auxiliary for the date and location of their next class.

The hazard warning symbols shown below are used throughout this manual to call attention to potentially dangerous situations which could lead to either personal injury or product damage. We urge you to read these warnings carefully and follow all safety recommendations.

⚠ DANGER

The symbol shown above alerts you to immediate hazards which **WILL** cause *severe personal injury or death* if the warning is ignored.

⚠ WARNING

The symbol shown above alerts you to hazards or unsafe practices which **COULD** result in *severe personal injury or death* if the warning is ignored.

⚠ CAUTION

The symbol shown above alerts you to hazards or unsafe practices which **COULD** result in *minor personal injury, or cause product or property damage* if the warning is ignored.

NOTICE

The symbol shown above calls attention to installation, operation or maintenance information which is important to proper operation, but is not hazard-related.

There is information in this manual related to the following **Ski Challenger boats:**

Ski Challenger 2081

Due to our ongoing commitment to product improvement, we reserve the right to change, without notice or other obligation, the specifications or other information contained in this publication.

⚠ WARNING

A qualified operator must be in control of the boat at all times. Do not operate your boat while under the influence of alcohol or drugs. Never operate your boat at speeds which exceed your ability to react if an emergency develops. At night, turn on the appropriate running lights and cruise at a reduced speed that will allow you plenty of time to avoid dangerous situations.



Table of Contents

PREPARATION

Recommendations for Safety	4
Safety Equipment	6
Tool Chest	7
Miscellaneous Items	7
Static Float Attitude	7
Other Tips	8

TRAILERING

8

OPERATING

Fueling Procedures	10
Launching	11
Starting	12
Before You Leave	13
Maneuvering	13
Boat Performance	16
Boat Running Attitude	16
Instruments	17

COMPONENTS/SYSTEMS

Electrical System	18
Fuel System	19

Shaft-Transmission Alignment	20
Shaft Log Stuffing Box Packing	21
Rudder Stuffing Gland	22
Starter Motor	22
Bilge Blower	22
Bilge Pump	22
Running Lights	23
Hot Air Hose and Heater	23
AM/FM Cassette Stereo	23
Depth Sounder	24

GENERAL MAINTENANCE AND REPAIRS

Bilges/Engine Compartment	24
Cabin and Topside Areas	25
Hull	27

STORAGE

29

NAUTICAL TERMS

31

WIRING DIAGRAMS

32

WARRANTY

33



PREPARATION

Prior to leaving on your first outing (or, for that matter, any outing) there are certain items to check and activities to perform. Familiarize yourself with your boat while dockside, and consider the following suggestions:

Recommendations for Safety

1. Personal Flotation Devices:

One Coast Guard approved personal flotation device (PFD) of suitable size is required for each person aboard a recreational boat. New PFDs bearing Coast Guard approval are now identified as Types I, II, III, or IV.

Requirements for boats sixteen feet (16') or over in length: One (1) Type I, II, or III (wearable) PFD for each person on board, and one (1) Type IV (throwable) PFD in each boat.

Requirements for boats less than sixteen feet (16') in length: One (1) Type I, II, III, or IV PFD for each person on board.

2. Always have children wear PFDs. Always check those devices intended for young children for fit and performance in the water. Never hesitate to have "all hands" wear lifesaving devices whenever circumstances cause the slightest doubt about safety.
3. Do not overload or improperly load your boat. Maintain adequate freeboard at all times. Consider the sea conditions, the duration of the trip, the weather and the experience of the personnel on board. **Do not allow anyone to ride on parts of the boat that were not designed for such use. Sitting up on seat backs, bow riding, gunwale riding, or lounging on forward sundeck cushions while underway can be especially hazardous.**
4. Falls are the greatest cause of injury both afloat and ashore. Eliminate tripping hazards where possible, make conspicuous those that must remain, and require that everybody on board wear proper footwear.
5. Understand the meanings of navigation buoys, and never moor to one. (It is a Federal offense.)

- 
6. Know the various distress signals. A recognized distress signal used on small boats is to slowly and repeatedly raise and lower the arms outstretched to each side.
 7. Storm signals are for your information and safety. Learn them and be guided accordingly.
 8. A special flag (red flag with a white diagonal stripe) flown from a boat or buoy means skin diving operations are underway nearby. Approach with caution and stay clear by at least 25 yards.
 9. Be especially careful when operating in any area where there might be swimmers.
 10. Watch your wake. It might capsize a small craft. You are responsible for damage caused by your wake. Pass through anchorages at a minimum speed.
 11. Learn and abide by common boating "rules of the road".
 12. Always have up-to-date charts of your cruising area on board.
 13. Keep an alert lookout. Serious accidents have resulted from failure in this respect.
 14. Always instruct at least one person on board in the rudiments of boat handling in case you are disabled or fall overboard.
 15. Consider what action you would take under various emergency conditions such as a person overboard, fog, fire, a damaged hull or other bad leaks, motor breakdown, severe storm or collision.
 16. If your boat ever capsizes, remember that if it continues to float, it is usually best to remain with it. You are more easily located by a search plane or boat.
 17. Keep firefighting and lifesaving equipment in good condition and readily available at all times.
 18. Do not test fire extinguishers by squirting small amounts of the agent. The extinguisher might not work when needed. Always follow approved instructions when checking fire extinguishers.

- 
19. Have an adequate anchor and sufficient line (at least six times the depth of the water) to assure a secure hold in all types of weather and sea conditions.
 20. Boat hooks are valuable when docking or when needed to retrieve objects that have fallen overboard.
 21. Keep electrical equipment and wiring in good condition. No knife switches or other arcing devices should be installed in fuel compartments. Allow ample ventilation around batteries.
 22. Good housekeeping in your boat is important. Cleanliness diminishes the probability of fire.
 23. Know your fuel tank capacity and cruising range. If it is necessary to carry additional fuel, do so only in proper containers. Take special precautions to prevent the accumulation of fuel vapors in confined spaces.
 24. Before departing on a boat trip, advise a responsible friend or relative about where you intend to cruise. Be sure to give that person a good description of your boat. Keep them advised of any changes in your

cruise plans. These precautions will enable your friend or relative to tell the Coast Guard where to search for you and what type of boat to look for if you fail to return. Be sure to advise the same person when you complete your trip to prevent any false alarms about your safety.

25. Your local United States Coast Guard Auxiliary and the United States Power Squadrons offer safe boating classes several times a year. These are comprehensive courses, and are generally of minimal cost to you. Call your local U.S. Coast Guard Auxiliary or Power Squadron Flotilla for the time and place of their next class.

Safety Equipment

The following safety-related items should be considered as part of your standard equipment:

1. Fire extinguishers (correct number and type, located for easy access)
2. Personal flotation devices
3. Fenders, lines and boat hook

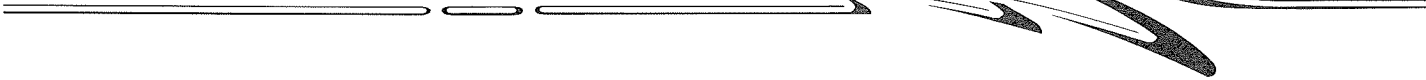
- 
4. Flares (night and day type)
 5. Flashlight(s) with extra batteries
 6. Charts of your intended cruising area
 7. First aid kit

Tool Chest

1. Assorted screwdrivers (Phillips and flat blade)
2. Pliers (regular, vise-grip, and water pump)
3. Wrenches (box, open-end, allen, and adjustable)
4. Socket set (metric and U.S. standard)
5. Hacksaw with spare blades
6. Hammer
7. Battery jumper cables
8. Electrical tape
9. Assorted fasteners
10. Gear grease and penetrating oil
11. Feeler gauges

Miscellaneous Items

1. Engine and accessories manual
2. Spare propeller with fastening hardware
3. Propeller shaft packing material
4. Spare shaft and strut
5. Extra V-belts
6. Engine lubricating oil
7. Transmission lubricant
8. Spare fuel and oil filters
9. An extra cooling pump impeller
10. Portable fuel can
11. Replacement light bulbs
12. Spare set of spark plugs and other ignition parts

Static Float Attitude

The static floating attitude of your boat can be affected by many variables. Optional equipment and loading of



gear are the biggest contributors to a boat's list. After launching, the floating attitude of any new boat can be adjusted. If your boat lists to one side, load heavy items on the opposite side until the boat floats more level. Load the remainder of your gear evenly after that.

Other Tips

1. When commissioning a new boat, do not plan an extensive trip or party until you have had a shakedown cruise to make sure all equipment on your boat is functioning properly and you are familiar with its operation.
2. Use big fenders or fender boards to protect your boat's hull whenever mooring next to floats, piers, or other boats.
3. Carry plenty of line that is properly sized to your boat. We suggest at least two 30' lengths of 3/8" nylon line.

TRAILERING

An Escort trailer, specifically designed for your Ski Challenger, should be used for trailering your boat. Use of

any other trailer requires careful checking to insure that capacity and support points are correct.

1. Before using your trailer, read the trailer owner's manual thoroughly.
2. Check your trailer's brakes for proper operation prior to departure on each trip. (Consult your state laws for trailer brake requirements and equip your trailer accordingly.)
3. Frequently check your trailer's wheel lug nuts for security.
4. Check the tires for proper inflation. Underinflated tires heat up rapidly and tire damage is likely to occur.
5. Wheel bearings should be checked at least every 90 days and before putting your boat away for the season.
6. Make it a habit to check the wheel hubs every time you stop for gas or refreshments. If the hub feels abnormally hot, the bearings should be inspected before continuing.

-
7. On extended trips, carry spare wheel bearings, seals and races.
 8. Check to be sure the taillights and turn signals work when attached to the towing vehicle. Some automobiles require heavy-duty flasher units to make turn signals work properly.
 9. Check your trailer's springs and undercarriage for loose parts.
 10. Your boat should be fastened to the trailer by a line from the bow eye to the winch, PLUS a safety chain or cable from the bow eye to the winch stand or trailer tongue. The stern of your boat should be tied down to the trailer from the stern eyes. Note that the boat transom-to-trailer tie-down straps and winch lines are designed for *normal* towing conditions on paved roadways and moderately rough secondary roads (at slow speeds only). They **should not** be relied upon for *any* lifting application. Also, we recommend the use of additional straps or rope tie-downs for securing the boat to the trailer, particularly for longer trips or whenever you expect to encounter rough roads.
 11. Too much or too little tongue weight will cause difficult steering and tow vehicle sway. A rough rule of thumb is that 5% to 10% of the boat and trailer weight should rest on the tongue.
 12. Close all hatches and doors. Store all loose equipment so that it cannot slide or fall.
 13. Carry a spare wheel and tire, along with the tools needed to change them.
 14. Before backing your trailer into the water, disconnect the light plug from the car. This will greatly reduce the chance of blowing out your trailer lights when they become submerged.

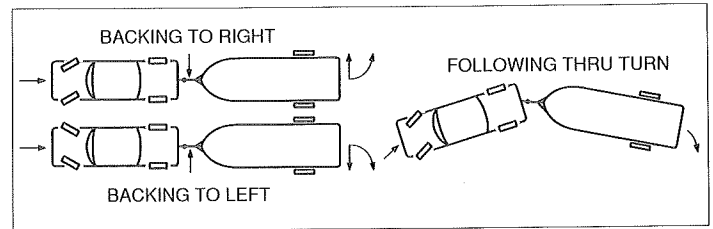

PRACTICE—PRACTICE—PRACTICE

Before attempting that first launch, tow your boat to a nearby empty parking lot and practice backing your trailer. Whenever you are backing up, be sure to have a lookout to help direct you.

If it is not already so equipped, consider installing a right side mirror on your tow vehicle.

When rounding sharp turns, remember to swing wide to avoid cutting the corner with the trailer.

OPERATING

Fueling Procedures

⚠ WARNING

Fuel vapors are explosive and can become trapped in the lower portions of a boat where they might be ignited accidentally. While fueling, all doors and hatches must be closed.

⚠ WARNING

Do not use fuels that incorporate any form of alcohol or alcohol derivatives. Alcohol destroys marine fuel system hoses and components, which could lead to hazardous leaks, fire or explosion.

Internal Fuel Tank

1. If you're going to fuel your boat while it's in the water, be sure it's securely moored to the dock.
2. Turn off all electrical equipment including the engine, appliances, bilge blower, lights, etc.
3. Extinguish all cigarettes, cigars or other items that may produce a spark or flame.
4. Close all hatches and doors.
5. Through-deck fittings are provided for fuel tank filling. Remove the cap and insert the fuel supply nozzle,

allowing the nozzle to maintain contact with the fitting; this will prevent possible static sparking.

6. Allow for thermal expansion of the fuel on very hot days. Do not fill the fuel tank completely.
7. If, when filling the tank, you can't put fuel in at a reasonable rate, check the fuel vent line to see that it's not kinked or plugged.
8. When you have finished fueling, replace the fill cap and wash off any fuel spillage.
9. Open the engine compartment and all doors and hatches; inspect, both visually and by smell, for fuel fumes or leakage. Any sign of fuel leakage, or any indication of fumes, must be investigated and corrected prior to starting the engine.
10. Operate the bilge blower for at least four minutes prior to starting the engine. Leave the blower on until the boat is underway and up to cruising speed.

Fuel Capacity Table

Ski Challenger Models	Tank Capacity (Gallons)
Ski Challenger 2081	25

Launching

1. Your Ski Challenger is equipped with a drain plug located amidships in the engine compartment. Make sure this plug is tightly in place.

⚠ CAUTION

Failure to install the drain plug securely will result in the boat filling with water when it is launched.

2. Once your boat is in the water, immediately board it and inspect the lower compartments for signs of leakage.

- 
3. If any leaks are noted, immediately remove the boat from the water. The selling dealer should be notified so the leaks may be repaired before relaunching the boat.

Starting

The engine operating and maintenance manual furnished with your boat describes prestart and starting procedures. The following notes are basic reminders, and are not intended to cover every detail of starting. We urge you to thoroughly read and understand your engine manual.

1. Check the lubricating and cooling fluid levels.
2. Visually check for fuel, oil, coolant, and exhaust leaks.
3. Make sure the emergency engine shutdown switch cap is in place and the lanyard is attached to the operator.

WARNING

A serious accident can occur if the emergency engine shutoff switch lanyard is not fastened to the boat operator. In order for the emergency engine shutdown system to operate correctly, the lanyard must be physically attached to the operator (around the wrist or securely fastened to a stout piece of clothing, such as a belt, etc.).

WARNING

Gasoline vapors are highly explosive. To prevent a possible explosion and fire, check the engine and fuel compartments before each engine start for fumes or accumulation of fuel. Always operate the bilge blower for at least four minutes before engine starting, during the starting process and anytime you are operating your boat below cruising speeds.

4. **Do not** continuously operate the starter for more than 15 seconds at a time. Allow at least three minutes for cooling between start attempts.

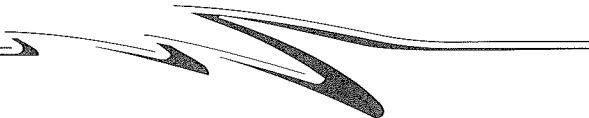
-
- 
5. On boats so equipped, check the oil pressure, voltmeter and temperature gauges immediately after the engine starts.
 6. Check the steering operation by turning the steering wheel full port and starboard while observing the rudder movement.
 7. While the boat is still securely moored to the dock, advance the shift control to forward, to reverse, and into neutral to check the shifting operation.

WARNING

Carbon monoxide is a poisonous gas that is colorless, odorless and heavier than air. It can accumulate in the lower regions of the boat in dangerous concentrations if proper ventilation is not provided. A person breathing these fumes could become seriously ill or even suffocate. Always run the bilge blower and open windows or hatches whenever the engine is idling. Also, never operate the engine when either the slant cover or the camper cover is installed.

Before You Leave

Provided you have not encountered any problems, you are almost ready to go. (If you did encounter problems, **do not** attempt to operate your boat until they are corrected.) Before you leave, perform the following steps:

1. Check the operation of equipment such as bilge pumps, running lights, radios, etc.
2. Instruct passengers in the use and location of flotation devices and fire extinguishers.
3. Obtain a reliable weather forecast and plan accordingly for everyone's comfort and safety.
4. Notify a responsible friend or relative of your cruise plans. Upon your return or a change in your cruise schedule, notify that person again in order to avoid unnecessary concern.

Maneuvering

With all of your predeparture checks now completed, you are ready to leave the dock.

Basic Maneuvering

Remember that all boats steer by the stern (the feeling is much like steering your automobile in reverse). For example, when you turn the steering wheel to the left, the stern of the boat will swing to the right as the boat goes into a left turn. This is especially important to keep in mind when docking, or when operating in close quarters with other boats.

There are no brakes on a boat. Stopping is accomplished by allowing the boat to slow down (under 5 mph) and then putting the engine in reverse. Gently increasing reverse power will allow you to stop the boat in a very short distance. A boat does not respond to steering in reverse nearly as well as it does when going forward, so do not expect to accomplish tight turning maneuvers when backing up.

Once you are away from the dock, devote some time to learning how to maneuver.

- Practice docking by using an imaginary dock.
- Practice stopping and reversing.
- When operating in close quarters or docking, all maneuvering should be done at idle speed. Proceed with caution in congested areas.
- Gradually increase your speed. Get used to the boat before attempting any full throttle operation.

Docking

Preparation:

Proper docking requires preparation. Start by making sure you have adequate mooring gear, and that it is stowed correctly and ready for use. Your dealer is the best source for information concerning the amount and type of equipment you should carry.

Approaching the Dock:

When approaching a mooring area, lower your speed within a reasonable distance to allow your wake to subside before it reaches other boats or docks. As you get close to your moorage, check for any wind or current action that may affect your maneuver; then make a conservative approach with these factors in mind. Try to use the elements to your advantage. Allow them to carry the boat into the dock. If there are high winds or strong currents, it is best to approach the moorage from the lee side. With a mild current and little or no wind, it is best to approach from the windward side. While approaching, check to see that all lines are attached to the cleats on the side facing the moorage. Also insure that fenders are lowered on that side. Be sure to check that the fenders are hung at the proper height.

As you approach your moorage, it is desirable to have

one person at the bow and one at the stern of the boat, each with a boat hook and a mooring line attached to a cleat. Approach at idle RPM at an angle approximately 45 degrees to the dock. When the bow is within a few feet of the dock (starboard side) the stern can be brought alongside the moorage by turning hard to port. Next, turn to starboard and at idle RPM put the boat into reverse. This will stop the boat and bring the stern even closer to the dock. These steps are reversed for docking to port.

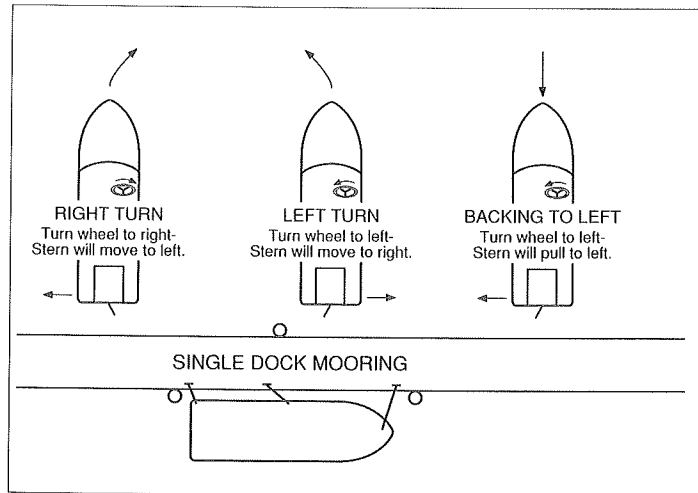

Mooring:

To attach lines to deck cleats, make a loop in one end of the line and pass it through the hole in the base of the cleat; then pass the loop back over the entire cleat. The line can now be used to secure your boat. Lines may be kept this way while underway as long as they are coiled and cannot become fouled in deck gear or props. In heavy sea conditions, all lines should be removed from the deck.

TIP: To tie up, run the line from your boat around the dock cleat and then back to your boat. This way you can untie the line without jumping from your deck to the dock and back again. Instead, just cast off one end of the line and bring the whole length back on board.

⚠ WARNING

Whenever you are towing another boat, or having your boat towed, make sure the towline is fastened securely to the bow or transom towing eyes only. Never attach a towline to deck cleats, as serious injury may result if the cleats pull free from the deck. Also, to reduce the danger created by a potential failure of the towline, everyone should stay well clear of the towline attachment points on both the towing and the towed boats.



Leaving the Dock:

Take into account wind, tide, current, and other forces that affect your maneuvering as you leave the dock. Most maneuvering to and from a dock is best accomplished at idle speeds.

Do not forget to release the mooring lines and stow the fenders.

When leaving a moorage on your starboard side and your bow cannot be pushed away from the dock first, start forward with the steering wheel turned to starboard for two or three feet. Then shift to reverse with steering full to port. Repeat if necessary to get the stern far enough away from the dock so you can back clear of any other boats that may be moored ahead of you. (Reverse steering wheel directions when leaving a dock located to port.)

Boat Performance

Boat speeds are affected by a great many factors. Some, such as temperature and altitude, you cannot change, but some factors you can:

1. Loading: Take only necessary equipment with you. Keep weight low in the boat and balanced.

2. Propeller: Keep it in good repair and at the correct pitch for your particular situation. The factory standard equipment propeller may not be the best for your particular boat and load conditions. If the engine RPM at full throttle is less than its maximum rating, try a prop of less pitch. If the engine RPM exceeds the maximum rating, try a prop of greater pitch.

A slightly bent or nicked propeller will adversely affect the performance of your boat.

3. Weeds, barnacles and other growth: Keep your boat's bottom clean. When your boat starts "growing grass", it will slow down greatly.

Boat Running Attitude

If your boat runs with its bow too high or too low at cruising speeds, try redistributing the extra gear you have loaded aboard. If the bow is too high, move some gear forward. If the bow digs in, causing steering difficulty or veering off course, move more weight aft.



Instruments

While under way, instruments should be checked frequently for possible indications of trouble.

1. *Tachometer*—A tachometer is an electrical instrument that indicates engine revolutions per minute (RPM). The tachometer is useful for monitoring engine speed to avoid exceeding the maximum RPM rating. In addition, it can be used to detect performance changes by comparing speedometer readings at various RPMs.
2. *Temperature Gauge*—The temperature gauge indicates engine coolant temperature by monitoring a signal from a sending unit installed in the engine water jacket. When the gauge reads in the danger area, shut off the engine and diagnose the problem. A common cause of overheating is picking up a foreign object in the seawater intake. Usually, backing up in reverse gear, then pulling ahead in forward gear for 10-15 feet will help to remove the blockage.
3. *Oil Pressure Gauge*—The oil pressure gauge indicates engine lubricating oil pressure. Low oil pressure readings are generally caused by low oil quantity.
4. *Fuel Gauge*—The fuel gauge indicates fuel level. Since boats are exposed to rough water conditions and varying degrees of trim, fuel gauges may provide inaccurate readings at times. It is always good to keep track of your running time as a double check against an inaccurate gauge.
5. *Compass*—You may want to equip your boat with a compass for use in marine navigation. Many factors affect the operation of your compass, such as local magnetic variation and deviation (induced needle deflection caused by metal components and the operation of electrical equipment aboard your boat). Each compass must be "swung" (compensated) to adjust for individual boat characteristics, and for the particular compass installation. It is vitally important, therefore, that you have your compass professionally swung before using it for marine navigation. Your Ski Challenger dealer can refer you to local shops that perform this work.

In any case, immediately shut down the engine and diagnose the problem.



COMPONENTS/SYSTEMS

Electrical System

⚠ WARNING

To reduce the risk of electric shock, only qualified personnel should install batteries and perform electrical system maintenance. You can minimize the danger of fire and explosion by not exposing the batteries to open flame or sparks. It is also important that no one smoke anywhere near the batteries. Because fuel fumes are heavier than air, they will collect in the bilge areas where they can be accidentally ignited. Operating the bilge blower for at least four minutes prior to engine starting, electrical system maintenance, or activation of electrical devices will decrease the danger of fire and explosion.

1. *Battery:*
The key to a good marine electrical system is the battery (the batteries are dealer-installed items).

Ski Challenger makes the following recommendations on battery rating:

Inboard Models — 500 cold cranking amps minimum

On some models the condition of the battery can be read on the voltmeter when the ignition switch is in the ON position.

With the engine not running, voltmeter readings in the 11.5 to 12.5-volt range are considered normal. Readings in the 10 to 11.5-volt range indicate a marginal charge condition. Readings below 10 volts indicate a seriously discharged condition.

With the engine running (over 1500 RPM), voltmeter readings of 13 to 14 volts are considered normal. Readings below this indicate a severely discharged battery or a nonfunctioning charging system.

Check the battery electrolyte level regularly.

Remove the caps on top of the battery and observe the level of the fluid inside. If the zinc plates are exposed, add distilled water until they are covered again. Corroded terminals can impair battery performance and charging ability. Clean them with baking soda and

water; then coat them with a preservative or a light film of grease. Be sure all battery connections are tight. When storing the boat, it is best to remove the battery, give it a full charge, and store it inside away from extreme temperatures.

2. *Fuses and Circuit Breakers:*

The engine and accessory circuits are protected by a large circuit breaker or fuse located on the engine.

The fuse block is located behind the instrument panel. Wires are color coded to indicate which accessory each fuse services. Some items, such as radios, may be fused individually at the unit.

Fuel System

CAUTION

It is very important that the fuel system be inspected thoroughly the first time it is filled and then at each subsequent filling. For your safety and the safety of your passengers, the fueling instructions in this manual must be followed.

1. *Fuel Fills and Vents:*

The fuel fill is located on the aft deck. Fuel receptacle caps are marked "Fuel" or "Gas". Fuel vents are normally located in the hull or transom below and in the same general area as the fill. If you experience difficulty filling the fuel tank, check to see that the fuel fill and vent lines are free of obstructions and kinks.

2. *Antisiphon Valves:*

As required by the U.S. Coast Guard, the fuel system on your boat is equipped with an antisiphon valve. This valve is an integral part of the barb fitting on the fuel tank to which the neoprene fuel line attaches. The valve is spring loaded and is opened by fuel pump pressure. These valves will prevent gasoline from siphoning from the fuel tank in the event of a fuel line rupture.

NOTICE

If an engine running problem is diagnosed as fuel starvation, the antisiphon valve should be checked. In the event the valve is stuck or clogged, it should be cleaned or replaced while the engine is shut down. Under no circumstances should it be removed except in an emergency.

3. *Fuel Filters:*

All fuel tanks are equipped with a fine mesh screen filter on the fuel pick-up tube in the tank. In addition, when supplied by the motor manufacturer, an additional filter is installed on the engine. Fuel filters should be checked periodically to see that they are clean and free of debris.

CAUTION

Avoid the storage or handling of gear near the fuel lines, fittings and tank.

Shaft-Transmission Alignment

Alignment between your engine transmission output shaft and the propeller shaft is very critical. Although this alignment has been performed at the factory, it should be checked again after the boat has been in the water for 48 hours. Alignment inspection should be performed as part of the routine maintenance program (after the initial 30 hours of operation, then every 60 hours) and whenever unusual noise or vibration is noticed. To insure proper

alignment when the boat has been launched after a haul-out or dry storage, wait for 48 hours before making final adjustments.

Proper alignment is usually achieved by moving the engine. We recommend that alignment be performed by an experienced marine mechanic. However, checking alignment is relatively simple when these procedures are followed:

1. Remove the flange bolts at the transmission-to-shaft coupling and slide the shaft aft until the flanges are about 1/4" apart.
2. Rotate the shaft to see if there is obvious "wobble" of the shaft flange; if there is, it may indicate that the shaft has been damaged.
3. Move the shaft up and down and from side to side to determine, as closely as possible, the central position where the shaft is normally located. At this position, the transmission flange should align with the shaft flange without moving the shaft to either side or raising it more than 1/8". If this is not the case, a misalignment condition exists.

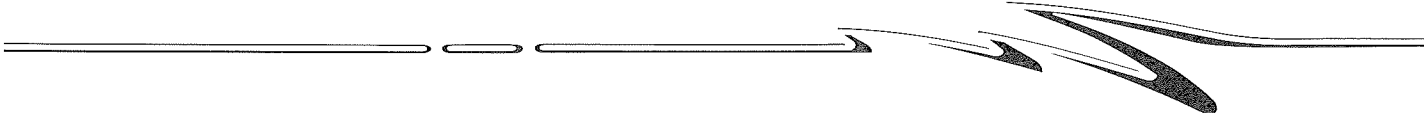
- 
4. Move the shaft flange into contact with the transmission flange. Check the gap between flange faces by attempting to insert a .003" feeler gauge at the top, bottom and each side. Repeat this operation after rotating the shaft flange 1/4 turn (3 times). Misalignment is indicated when the feeler gauge can be inserted easily at any point.

Shaft Log Stuffing Box Packing

The propeller shaft emerges from the bottom of the boat through an opening called the shaft log. The shaft stuffing box is connected to the shaft log by a short length of special flexible hose. Packing rings are compressed around the shaft by the packing nut. The stuffing box prevents excessive amounts of water from leaking around the shaft and into the boat.

Normal wear can cause stuffing box leakage to increase. It usually can be stopped by loosening the locknut, tightening the packing nut slightly, and then resetting the locknut tightly. Do not overtighten the locknut. Bear in mind that a **slight leak** (up to 10 drops per minute while running) helps to lubricate the packing and is therefore **desirable**.

When stuffing box leakage becomes excessive, even after following the above steps, packing replacement can be performed as follows:

1. Remove the boat from the water.
2. Loosen the locknut; then back the packing nut off the sleeve. Remove the old packing.
3. Wrap new packings around the shaft; then cut the rings with a razor blade at an angle approximately 30 degrees to the long axis of the shaft. Stagger the ends of each ring around the shaft and insure that the rings are fully seated in the packing nut recess.
4. Tighten the packing nut by hand only until resistance of the packing contacting the stuffing box is felt. Then tighten the locknut securely.
5. When initially launched, the packing must be allowed to leak at a rate of about 5 to 30 drops a minute, as it will expand and seal from water contact and friction heat from the turning shaft. Failure to allow this leakoff will result in packing burnout after running for only a short period of time.

Rudder Stuffing Gland

As in the case of the shaft log stuffing box, the rudder stuffing gland is part of the assembly where the rudders emerge from the bottom of the boat.

It is very similar to the propeller shaft stuffing box and will require the same maintenance. Since it obviously does not receive the same wear as the propeller shaft, repacking is seldom required. This shaft stuffing gland should not leak water.

Starter Motor

The engine starter motor is designed to deliver high horsepower for only very short periods of time. Avoid operation for more than 15 seconds at a time. Due to its high horsepower, this motor builds up considerable heat and can be permanently damaged with prolonged use. If it does not operate, check the battery charge and all direct wiring for shorts or loose connections. If excess bilge water is allowed to accumulate, the starter can be damaged. Automatic bilge pumps are recommended for boats left in open moorage.

Bilge Blower

The bilge blower removes fumes from the engine compartment and draws fresh air into the compartment through the deck vents.

To insure fresh air circulation, the bilge blower is to be used before starting the engine, during starting, and while the boat is operating below cruising speed. Operate the blower for at least four minutes before starting the engine.

⚠ WARNING

Operation of the blower is NOT A GUARANTEE that explosive fumes have been removed. If you smell any fuel, shut off the engine and all electrical accessories and investigate immediately.

Bilge Pump

The electric bilge pump supplied with your Ski Challenger is an impeller-type pump. If bilge water is present and the pump motor is running but not pumping, check to see if it is clogged by debris. If it is clear but still does not pump, check the discharge hose for kinks or a collapsed area.

NOTICE

The Federal Water Pollution Control Act prohibits the discharge of oil or oil waste into or upon the navigable waters and contiguous zone of the United States if such discharge causes a film or sheen upon, or discoloration of, the surface of the water, or causes a sludge or emulsion beneath the surface of the water. Violators are subject to a penalty of \$5000.

Running Lights

Although the night lights or navigation lights supplied with your Ski Challenger are of top quality, failure may occur for a variety of reasons:

1. There may be a blown fuse. (Replace the fuse in the switch panel.)
2. The bulb may be burned out. (Carry spare bulbs for replacement.)
3. The bulb base may be corroded. (Clean the base periodically and coat it with nonconductive grease.)
4. A wire may have come loose or may be damaged. (Repair as required.)

NOTICE

Prolonged operation of lights (overnight) will result in a dead battery. Be conservative in the use of battery power.

Hot Air Hose and Heater

Hot water from the engine cooling system is routed through a heat exchanger mounted in the bow of the boat. When you activate the heater switch on the dash panel, warm air is delivered through flexible ducting to two vents mounted near the floor. The starboard vent provides heat for the boat's operator. The center vent is attached to an expandable hose which can be pulled out and used for warming observers and skiers, or for drying wetsuits, hair, etc.

AM/FM Cassette Stereo

The AM/FM cassette stereo that comes standard with your Ski Challenger has a separate brochure that explains its operating features. Note that AM/FM radio reception will be impaired anytime the engine is running, and therefore it is suggested that you turn the radio off while underway.

Depth Sounder

You may wish to equip your Ski Challenger with an electronic depth sounder. It will provide you with measurements of water depth beneath the boat. In many cases it also will help you locate schools of fish. The depth sounder comes with its own owner's manual. We suggest that you read it carefully before turning on the unit.

WARNING

The depth sounder should not be used as a navigation aid to prevent collision, grounding, boat damage or personal injury. When the boat is moving, submerged objects will not be seen until they are already under the boat, or bottom depths may change too quickly to allow time for the boat operator to react. Always operate the boat at very slow speeds if you suspect shallow water or submerged objects.

GENERAL MAINTENANCE AND REPAIRS

In addition to instructions found elsewhere in this manual and in the literature specific to certain components, the following information is provided for general maintenance and repair.

Because conditions vary widely in different areas, and the frequency and type of use can differ greatly between owners, intervals for maintenance are not listed here. Common sense should determine the frequency of maintenance.

Bilges/Engine Compartment

1. Pump the bilges dry and remove all loose dirt. Be sure that all limber holes are open. If there is oil in the bilge and the source is not known, look for leaks in engine oil lines or engine gaskets. Oil stains can be removed by using a bilge cleaner available from your dealer or a marina. **DO NOT** use flammable solvents.
2. Check all wiring to be sure it is properly supported, that its insulation is intact, and that there are no loose or corroded terminals. If there are corroded terminals,

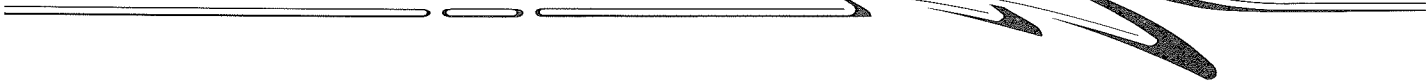

they should be replaced or thoroughly cleaned with sandpaper. Tighten all terminals securely and spray them with WD-40 or similar preservative.

3. Inspect the entire fuel system (including fill lines and vents) for any evidence of leakage. Any stains around joints could indicate a leak. Try a wrench on all fittings to be sure they are not loosening, but do not over-tighten them. Clean fuel filters and vent screens.
4. Inspect the entire bottom for evidence of seepage, damage or deterioration, paying particular attention to hull fittings, hoses and clamps. Straighten kinked hoses and replace any that do not feel pliable. Tighten loose hose clamps and replace those that are corroded. Tighten any loose nuts, bolts or screws.
5. Refer to your engine operating manual for engine maintenance details. Wipe off engines to remove accumulated dust and grease. If a solvent is used, make sure it is nonflammable. Go over the entire engine and tighten nuts, bolts, and screws, including the mounts. Inspect the wiring on the engine and clean and tighten the terminals. Inspect the belts and tighten them if needed. Replace any belt that is

cracked or frayed. Clean and lubricate the battery terminals; fill the battery cells with distilled water as needed.

Cabin and Topside Areas

1. Check bow rails, ladders and grab rails for loose screws, breaks, sharp edges, etc., that might be hazardous in rough weather. Inventory and inspect life jackets for tears and deterioration. Check your first aid kit to make sure it is complete. Check the signaling equipment. Inspect anchor, mooring and towing lines and repair or replace as required. **DO NOT** stow wet lines or they may mildew and rot.
2. Salt and brackish water are capable of etching and damaging window glass. Keeping windows clean is the best preventive measure you can take. When window cleaning, flush with plenty of fresh water.

Exercise caution when cleaning windows and doors made of plexiglass because it tends to scratch easily.

First, use generous amounts of water to wash off as much dust as possible. Use your bare hands with plenty of water to dislodge any caked dirt. Then use a

- 
- soft, grit-free cloth or soft, clean sponge with a cleaner made especially for plexiglass. Never use a glass cleaning solution or a duster as they will scratch the surface. **DO NOT** use solvents such as acetone, kerosene, benzene, carbon tetrachloride, fire extinguisher fluid, dry cleaning fluid, or lacquer thinner since they will attack the surface. When you are finished, rinse with fresh water and dry with a clean, damp chamois using a blotting action.
3. To keep teak looking fresh, it should be treated with teak oil at least twice a year (more often if exposure is severe). If the teak is in particularly bad condition, the teak oil should be rubbed in using 220 grit wet-or-dry sandpaper.
 4. Stainless steel railings and fittings should be cleaned with soap and water or household glass cleaner. Because irreversible pitting will develop under rust that remains on stainless steel for any period of time, it is best to remove rust spots immediately with brass, silver or chrome cleaner. Then coat the railing or fitting with a good automobile or boat wax. Never clean with mineral acids or bleaches. Also, do not allow stainless steel to come into continuous contact with iron, steel or other metals which could cause contamination leading to rust or corrosion.
 5. A variety of high quality fabrics have been used in the construction of your boat. Proper care and cleaning of all fabrics will contribute to their long life.

Prior to cleaning any fabric, we suggest that you **test your cleaning solution and method on a hidden or inconspicuous area.**

Canvas covers and vinyl upholstery can be cleaned using a mild soap and water solution. Vinyl cleaners and conditioners are **NOT** recommended for use on Ski Challenger upholstery. To prevent rainwater seepage at the seams, a coating of "Scotch Guard" can be applied on the inside of the vinyl. Mildew can occur if your boat does not have adequate ventilation. Heat alone will not prevent mildew. If mildew does occur, it can often be removed using a solution of hot water and laundry bleach (one cup of bleach to one gallon of hot water). Brush the solution into the affected area, let it sit for 10 to 15 minutes and rinse with plenty of fresh water. If at all possible, your boat's vinyl seats should be stored indoors in a fairly warm, dry place. This will greatly extend the life of the material.

Dry cleaning should be considered for interior fabrics other than vinyl.

-
- 
6. When instruments are exposed to a saltwater environment, salt crystals may form on the bezel and the plastic covers. These salt crystals should be removed with a soft, damp cloth; never use abrasives or rough, dirty cloths to wipe plastic parts. Mild household detergents or plastic cleaners can be used to keep the instruments bright and clean.

Hull

1. The finish on a fiberglass boat is similar to that of an automobile and will respond to the same system of care and cleaning. Car waxes and cleaners are often used to maintain a sparkling finish. Also, a variety of polishes and cleaners for fiberglass are now on the market. We suggest that you experiment with different brands to determine what you like best.
2. Almost unavoidable during the life of your boat is damage to the gelcoat or colored surface. This is not as serious as you might think. Repair is not costly and can be done by the novice.

Scratches: If the scratch does not penetrate the gelcoat surface, it can be repaired with automotive rubbing compound. Dampen a soft rag and apply the compound by rubbing in a circular motion. The scratch may not disappear completely; however, its noticeability will decrease.

Gouges and Chips: To repair, obtain "patch paste" from your Ski Challenger dealer and follow this recommended procedure:

- Clean the area to be repaired of wax and oil. Acetone is a good solvent.
- Mix a small portion of patch paste and catalyst on a piece of cardboard (two or three drops of catalyst to a tablespoon of paste).
- Apply the paste to the gouge with a putty knife or flat-edged stick; try to match the paste to the surface contour of the area being repaired. It is better to have an excess of paste, rather than not enough.
- Allow the paste to harden thoroughly. In most climates, one to two hours should be sufficient.
- Shape the patch as desired using fine wet sandpaper.
- Finish by using automotive rubbing compound in the same manner as you did for small scratches.



⚠ WARNING

Teak oil, acetone and catalyst are hazardous materials and should be used only in well ventilated areas. Follow the manufacturer's instructions. Also, never store rags that have been wetted with acetone, teak oil, fuel or any other solvent aboard your boat. Immediately remove them from the boat and discard them to prevent spontaneous combustion and fire.

3. Special Care for Boats That Are Moored

If permanently moored in saltwater or fresh water, your boat will collect marine growth on its bottom. This will detract from the boat's beauty and greatly affect its performance. There are two methods of preventing this:

- Periodically haul the boat out of the water and scrub the bottom with a bristle brush and a solution of soap and water.
- Paint the hull below the waterline with a good grade of antifouling paint.

NOTICE

Ski Challenger recommends the application of an epoxy barrier coating, such as International Paint Company's Interlux "Interprotect 2000 System", to help seal the hull bottom and reduce the possibility of gelcoat blistering on any boat that is permanently moored. The barrier coating should be covered with several coats of antifouling paint. Note that many states regulate the chemical content of bottom paints in order to meet environmental standards. Check with your local Ski Challenger dealer about recommended bottom paints, and about laws that are in effect in your area.

4. Whenever your boat is out of the water you should check all metal parts for stray current corrosion. Stray current corrosion, or electrolysis, can be prevented several ways. The following are the most common causes and the simplest cures:
- Wiring may leak a certain amount of electricity. Keep a clean, dry bilge.

- 
- A poorly grounded zinc anode: Check the ground wire and clean all contact surfaces.
 - The zinc anode may be deteriorated beyond effectiveness. Replace it when it has deteriorated 50% or more.
 - Do not use a copper-based bottom paint as it can cause electrolysis on some metal parts. If your boat is permanently moored, we recommend that you contact someone in your area specializing in corrosion control and have them check your boat in its moorage to see that it is properly protected.
5. Propellers should be inspected often for damage. Every attempt has been made to equip your boat with a propeller that will optimize performance. However, your boating needs may dictate a propeller change. Your Ski Challenger dealer can help you in the selection of propellers better suited to your needs.

On those high performance Ski Challenger models capable of speeds in excess of 50 mph, "cavitation burn" may be experienced on the propeller. Propellers on these boats should be checked frequently for cavitation burn if the boat is continuously operated at high speeds. Replace propellers as necessary when severe burn occurs. High performance propellers

constructed of bronze or stainless steel are available from the propeller manufacturers, but using these could void your warranty.

STORAGE

The following suggestions are offered for storage at the end of your boating season.

1. Your boat should be stored under cover if possible. If covered storage isn't available, a temporary winter cover is recommended. A proper winter cover should keep weather off the boat, but still provide adequate ventilation. Wrapping a boat up in a tight plastic cover can do more damage than good. Dampness and lack of air circulation provide ideal conditions for fungi that cause mildew and dry rot.
2. If you are storing your boat on its trailer:
 - Now is a good time to repack the trailer's wheel bearings. Your local auto service center can help you.

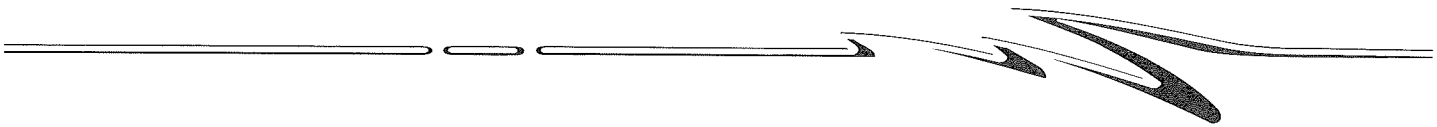
- 
- Block the trailer wheels off the ground to avoid tire deterioration.
 - Loosen the stern tie-downs to avoid stress on the hull.
3. Refer to your engine manual for engine storage instructions.
 4. Remove the marine battery from the boat. Fill the cells to the proper level and store your battery in a warm place. A fully charged battery will survive storage better.
 5. Fuel tanks should be filled so there is little air space, thereby minimizing condensation.
 6. Thoroughly clean your boat. If possible, remove cushions, blankets, towels, and other items that can hold moisture and cause mildew. Such items left on board should be positioned for maximum air circulation. It helps to stand cushions on edge.
 7. Clean all deck hardware; then coat the hardware with rust inhibitor.
 8. Lubricate the steering mechanism and throttle control linkage.

We hope these preventive measures will help make getting ready again in the spring easier. Should you have any questions, your Ski Challenger dealer is eager to provide assistance.



NAUTICAL TERMS

ABEAM:	On either side of the boat.	KNOT:	Nautical mile per hour; one nautical mile is 6,076 ft.; a land mile is 5,280 ft.
AFT:	To the rear, or near the stern.	LEE:	Opposite side from which the wind blows.
BEAM:	The width of the hull.	MAYDAY:	International spoken distress signal for radiotelephone communications.
BILGE:	The lowest portion inside a boat (in a fiberglass boat, generally the underdeck and lower portion of the engine compartment).	PORT:	To the left side of the boat.
BOW:	The forward portion of the boat.	PORTLIGHT:	A hinged window in the boat's cabin or hull.
CHINE:	The intersection of the side and bottom of a V-bottom boat.	SCUPPER:	An opening in a deck or cockpit permitting water to drain overboard.
DRAFT:	Vertical distance from the waterline of the boat to the lowest point of the boat.	STANCHION:	A fixed, upright post used for support (of rails or lifelines).
FATHOM:	A measurement of six feet, generally used to measure water depth.	STARBOARD:	To the right side of the boat.
FREEBOARD:	Vertical distance from the deck to the waterline.	STERN:	The rear of the boat.
GUNWALE:	The point where the hull and deck meet.	STERN DRIVE:	Inboard/outboard propulsion unit.
HATCH:	A covered opening in the deck.	TRANSOM:	The vertical part of the stern.
HEAD:	Toilet or toilet room.	WINDWARD:	The direction from which the wind is blowing.
HELM:	Steering wheel.		
KEEL:	The lowest external portion of the boat.		

WIRING DIAGRAM

2081 Ski Challenger

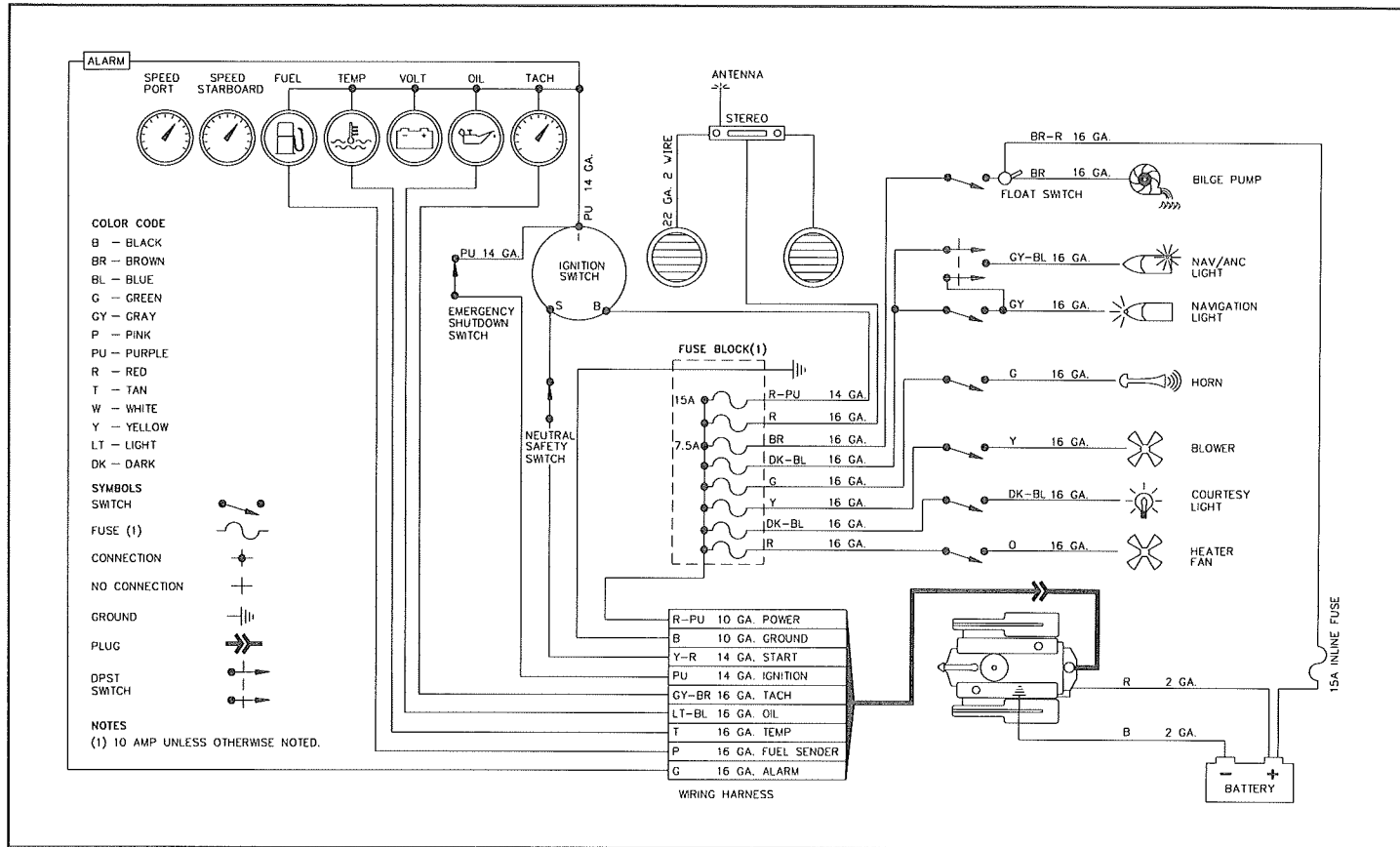

LIMITED WARRANTY

Ski Challenger warrants to the original purchasers of its 1990 model boats, purchased from an authorized Ski Challenger dealer, operated under normal, noncommercial use that the Selling Dealer will: (A) Repair any structural hull defect which occurs within five (5) years of the date of delivery; and (B) Repair or replace any parts found to be defective in factory material or workmanship within one (1) year of the date of delivery.

What Is Not Covered

This warranty does not apply to: (1) Engines, drive trains, controls, props, batteries, or other equipment or accessories carrying their own individual warranties; (2) Engines, parts or accessories not installed by Ski Challenger; (3) Window breakage or leaks; cosmetic gelcoat finish, i.e., discoloration, blisters, cracks or crazing; (4) Hardware, vinyl tops, vinyl and fabric upholstery, plastic, metal, wood or tape trim; (5) Any Ski Challenger boat which has been altered, subjected to misuse, negligence or accident, or used for racing purposes; (6) Any Ski Challenger boat which has been overpowered according to the maximum horsepower specifications on the capacity plate provided on each Ski Challenger outboard boat; (7) Any Ski Challenger boat used for commercial purposes; (8) Any defect caused by failure of the customer to provide reasonable care and maintenance.

Other Limitations

THERE ARE NO OTHER EXPRESS WARRANTIES ON THIS BOAT. TO THE EXTENT ALLOWED BY LAW:

1. Any implied warranty of merchantability is limited to the duration of this written warranty.
2. Neither Ski Challenger nor the Selling Dealer shall have any responsibility for loss of use of the boat, loss of time, inconvenience, commercial loss or consequential damages.
3. Some states do not allow limitations on how long any implied warranty lasts, so the above limitation may not apply to you. Some states do not allow the exclusion or limitation of incidental or consequential damages, so the above limitation or exclusion may not apply to you. This warranty gives you specific legal rights, and you may also have other rights which vary from state to state.

Your Obligation

In order to comply with Federal regulations, it is essential that your warranty registration card be submitted within 30 days of delivery of your boat. Return of this card is a condition precedent to warranty coverage. Before any warranty work is performed, we require that you contact your Selling Dealer to request warranty assistance.

We require that you return your boat, at your expense, to your Selling Dealer or, if necessary, to the Ski Challenger factory. You will be responsible for all transportation, haulouts and other expenses incurred in returning the boat for warranty service.

Challenger Marine
PO Box 9019
Everett, WA 98206
Phone (206) 435-6534

SKI CHALLENGER

Challenger Marine, P.O. Box 9019, Everett, WA 98206 USA
Telephone (206) 435-6534 Fax (206) 435-8034 Telex 474-0071

An affiliate of US Marine, a Brunswick Company