

BAYLINER®



OWNER'S MANUAL

Welcome Aboard

The purpose of this manual is to inform and familiarize both the novice and seasoned skipper with his new equipment. It will not tell you everything there is to know about boating, but will assist with the operation of equipment built and supplied by Bayliner. (Equipment, specifications and price subject to change without notice.) When your Bayliner needs service, see your authorized Bayliner dealer.

Understanding your new boat and how it works is essential to boating enjoyment and your safety. We recommend a four-step program for full boating pleasure.

1. Make certain you get a full explanation of all systems from your dealer before taking delivery.
2. Read this manual thoroughly, with particular emphasis on these points:
Fueling, Checking for Fumes, Starting, Carbon monoxide, Alcohol stoves, Loading limits, Trim tabs, Recommendations for Safety, and Limited warranty.
3. Practice. All members of the family should be familiar with boat operation and how all systems work.
4. Register for local power squadron safe boating course or equivalent.

Table of Contents

SECTION I

Recommended Procedures:

Launching	4
FUELING AND CHECKING FOR FUMES	4
STARTING	5
CARBON MONOXIDE	6
Controls	7
Safety Inspections	8
Trailer	9
How to Back Up Your Trailer	10
Getting Away From the Dock	11
Practice Maneuvers Under Power	11
Docking	12

SECTION II

Parts and Systems—Operations and Maintenance

Electrical Systems	14
Battery	15
Fuses and Circuit Breakers — 12V	15
Dockside Power	17
110/12V Refrigeration	18
Hot Water Heater	18
Generator (3250 - 3870 models)	18
Battery Charger (2450 - 2860 models)	19
Battery Charger (3250 - 3870 models)	19
Wiring Diagrams	20-29
Fuel Systems	30
Freshwater System	31
Starter Motor	33
Bilge Blower	33
Bilge Pump	33
Running Lights	33
Windshield Wiper	34
Head Operation:	
Marine Head with Holding Tank	34
Portable Heads:	
Passport	35
VIP 3	36
Holding Tank Valve Chart	37
Alcohol Stoves	38
Electric Alcohol Stoves	39
Electric Stove Operation	39
Propane Stoves	39
LOADING LIMITS, HARDTOPS, CABIN TOPS,	
COMMAND BRIDGES	40
Transom Platforms	40
Stuffing Box Packing	40

SECTION III

Underway Operation Instructions:

Instruments 41
Boat Performance 41
Boat Running Attitude 42
TRIM TABS (optional) 42
Operating Dual Station Boats 43
Steering Wheel Pressure 43
Static Float Attitude 43
Tips for Boat Owners 44
Boating Safety Courses 44

SECTION IV

General Maintenance and Repairs:

Fiberglass Staining and Discoloration 45
Hardware Cleaning 45
Vinyl Upholstery 45
Vinyl Flooring 45
Textured Vinyl Wall Coverings 45
Structafoam Transom Platforms and Steps 45
Teak 46
Repairing Fiberglass, Gelcoat Chips, Gouges and Scratches 46
Special Care for Boats That Are Moored 47
Underwater Corrosion 47
Cabin Windows 48
Window Leakage 48
Convertible Tops and Back Covers 48
Instruments — Care and Service 48

SECTION V

Winterizing 49

SECTION VI

Propeller Recommendations 50

SECTION VII

RECOMMENDATIONS FOR SAFETY 52

SECTION VIII

Nautical Terms 55

LIMITED WARRANTY FOR BAYLINER BOATS 56

YOUR OBLIGATION 56

Section I

Recommended Procedures for Launching, Fueling, Operating, Safety Inspecting, Trailering and Docking Your Boat.

IMPORTANT: At the time of the first launching of your new Bayliner, it is very important that the procedure noted below be followed. Bayliner power boats in the 2150 through 2850 series are water-tested at our factories on a random sample basis only. Therefore, your new Bayliner must be checked closely when first launched.

Launching

1. Each Bayliner power boat is equipped with a transom drain plug. Make sure this plug is in place and tight.
2. Inspect the bottom of your new Bayliner and make a mental note of all fittings below the waterline. Then proceed with the launching.
3. Once in the water, immediately board your boat and inspect the motor compartment for signs of leakage. Check the area of any other through-the-hull fittings for signs of leakage.
4. If any leaks are noted, the boat should be removed from the water. If the selling dealer is not present, he should be notified so the leaks may be repaired before relaunching the boat.

FUELING AND CHECKING FOR FUMES

1. **CAUTION: Prior to fueling, extinguish all open lights, close all hatches, windows and other doorways, stop all engines, motors, fans, and other devices liable to produce sparks.**
2. Inboard models are fitted with a through-the-deck fitting marked "Fuel". Remove the cap and insert the fuel nozzle, allowing the nozzle to make contact with the through-the-deck fitting. This contact will protect against static electricity.
3. Open the motor box or deck hatch, exposing the motor/fuel tank area, and proceed with filling the tank. After 10 or 15 gallons have been pumped in, stop to inspect the area of the engine and fuel tank for signs of leakage or fumes. If nothing is detected, proceed with fueling. When the tank is full, again check the motor/fuel tank area.
4. Install the fuel cap.
5. Wash down the area around the fuel-fill with fresh water.
6. On very hot days allow for expansion. Do not fill the fuel tank completely.
7. If, when filling the tank, you can't put fuel in at a reasonable rate, check the fuel vent line to see that it's not kinked or plugged.

8. A periodic check should be made of the engine/fuel tank area. Any sign of fuel seepage or fumes should be investigated and the cause repaired prior to operating the boat.

STARTING

1. Single Lever (Sidemount) Control

With the engine cover or floor hatch still open, proceed as follows to start the engine.

- a. Check the engine oil level, test alternator/water pump belts for tension and check entire engine area to see that everything is in its proper place.

CAUTION: Check entire area visually as well as by sniffing to insure that no fuel vapors are present.

WARNING: Gasoline Vapors Are Highly Explosive. To prevent explosion and fire, check engine and fuel compartments before each use for fumes or accumulation of fuel. Always operate blower for at least four minutes before starting, during starting and when operating below cruising speeds.

- b. Turn on blower and run it for four minutes. Do not turn blower off until you are underway and at cruising speed.
- c. Put throttle in neutral position. Pull base of throttle out and away from throttle side mount or throttle binnacle to disengage shift mechanism. Depress tab on underside of throttle handle to permit advancement.
- d. Advance throttle lever to max throttle position 2-3 times and return it to $\frac{1}{4}$ throttle position.
- e. Turn key to start position. Note engine will not turn over unless shift mechanism is in the neutral position or has been disengaged as described in step c.
- f. If engine fails to turn over, wait one minute and follow step d with the one difference being only advance the throttle handle once to max position.
- g. As soon as the engine starts, set the engine speed at 2000 r.p.m.'s and check your oil pressure. Oil pressure will vary from one engine to another, but it should come up immediately. If it doesn't, shut the engine off.
- h. When the oil pressure checks "OK", check the engine again for fuel vapors or fuel leakage. Give particular attention to all fuel fittings. Also check for any sign of water. Water leaking from the engine might indicate the blockdrain plugs are open.
- i. If everything checks "OK", close the engine cover.
- j. Return to the helm and check the volt meter. The volt meter should be in the green at 12-14 volts. The temperature gauge should start coming up.

- k. Now bring the engine back to an idle. Idle r.p.m. should be 600-800 when the engine is warm.

WARNING: CARBON MONOXIDE IS A POISONOUS GAS.

IDLING AT THE DOCK FOR LONG PERIODS OF TIME, OR RUNNING YOUR BOAT WITH THE CAMPER BACK COVER OR SLANT COVER INSTALLED WITHOUT ADEQUATE VENTILATION CAN RESULT IN DANGEROUS ACCUMULATIONS OF CARBON MONOXIDE GAS INSIDE THE BOAT. ALWAYS REMOVE THE CANVAS OR OTHERWISE VENTILATE THE BOAT WHEN OPERATING THE ENGINES.

2. Dual Lever Controls

With the motor box or floor hatch still open, proceed as follows to start the engine.

- a. Check the engine oil level, test alternator/water pump belts for tension and check entire engine area to see that everything is in its proper place.

CAUTION: Check entire area visually as well as by sniffing to insure that no fuel vapors are present. Check transmission oil level on inboard models.

WARNING: Gasoline Vapors Are Highly Explosive. To prevent explosion and fire, check engine and fuel compartments before each use for fumes or accumulation of fuel. Always operate blower for at least four minutes before starting, during starting and when operating below cruising speeds.

- b. Turn on blower and run it for four minutes. Do not turn blower off until you are underway and at cruising speed.
- c. Advance the throttle fully to set the automatic choke, then pump the throttle two or three times and turn the ignition key to the start position.
- d. As soon as the engine starts, set the engine speed at 1200 r.p.m.'s and check your oil pressure. Oil pressure will vary from one engine to another, but it should come up immediately. If it doesn't, shut the engine down.
- e. When the oil pressure checks "OK", check the engine again for fuel vapors or fuel leakage. Give particular attention to all fuel fittings. Also check for any sign of water. Water leaking from the engine might indicate the blockdrain plugs are open.
- f. If everything checks "OK", close the motor box floor hatch.
- g. Return to the helm and check the volt meter. The volt meter should be in the green at 12-14 volts. The temperature gauge should start coming up.
- h. Now bring the engine back to an idle. Idle r.p.m. should be 600-800 when the engine is warm.

WARNING: CARBON MONOXIDE IS A POISONOUS GAS.

IDLING AT THE DOCK FOR LONG PERIODS OF TIME, OR RUNNING YOUR BOAT WITH THE CAMPER BACK COVER OR SLANT COVER INSTALLED WITHOUT ADEQUATE VENTILATION CAN RESULT IN DANGEROUS ACCUMULATIONS OF CARBON MONOXIDE GAS INSIDE THE BOAT. ALWAYS REMOVE THE CANVAS OR OTHERWISE VENTILATE THE BOAT WHEN OPERATING THE ENGINES.

3. Diesel Engines

Be sure to read carefully and follow manufacturer's instructions provided with engine.

- a. Move the battery switch on.
- b. Insert the key into the starter switch. Turn the key to ON and check the meter to work properly. If there is anything wrong, switch off the starter switch and determine the cause of malfunction.
- c. To start engine when the engine is cold pre-heat the engine pushing glow plug button for about 15-30 seconds. This procedure must be repeated several times in cold weather.
- d. Set the accelerator lever (fuel and speed control lever) to the "START" position, then start the engine by turning the key to the "START" position. As soon as the engine starts, leave off your hand from the key. It will automatically return to the "ON" position.
- e. After the engine starts, set the accelerator lever to the proper position.
- f. If the initial firing does not occur though above starting action is repeated two times, check fuel and electric systems.
- g. Do not operate the starter continuously for more than 15 seconds at a time. When the engine does not start on the first attempt, wait more than 30 seconds before trying again.

4. Diesel Stopping Instruction

- a. Let engine idle 4-5 minutes.
- b. Depress kill switch(es).
- c. Turn Key(s) to off position.

Controls

With the boat tied securely to the dock, advance the shift control to forward. Bring back to neutral, hesitate and bring the shift lever back to reverse. Return lever to neutral. The boat thrust should correspond to the shift lever position. When shifting in or out of gear, move the shift lever firmly and quickly.

On inboard and stern drive models, have someone watch the rudder or lower unit while you turn the steering wheel to port and to starboard.

When you turn to port, the rudder or outdrive should swing to port. The same is true for outboard powered boats.

If you have followed the procedures above, then the most important functions of your boat have been checked. Any discrepancies noted should be reported to your dealer immediately. **WARNING: DO NOT ATTEMPT TO OPERATE YOUR BOAT UNTIL THE PROBLEM IS CORRECTED.** If everything checks out OK, you're ready to go boating. Have Fun!!!

For maximum safety and fun afloat, the procedures above should be followed each time you operate your boat. They are not just for beginners. Seasoned skippers, like airplane pilots, perform these checks each time they launch, fuel or operate their boats.

Safety Inspection

1. You should check to make sure you have the following safety items, tools and spare parts on boats.

- Fire extinguisher
- Life preservers—one for each person aboard, one throwable flotation device, all with a Coast Guard approval tag.
- Boat hook or paddle
- Fenders
- Lines
- Chart for intended operation area
- Flashlight
- Flares, night and day types
- Small tool box with:

Philips head screwdriver, slot head screwdriver, pliers, vise-grip, regular open-end wrenches, electrical tape, Allen wrenches, jack-knife, hacksaw, hammer, feeler gauges, lubricating oil, battery jumper cables, friction tape, water pump pliers, ratchet, sockets, extension, hose clamps, screws, bolts, nuts, washers, waterproof matches.

NOTE: Metric tools are required for diesel engines.

Spare Parts

- Alternator belt and/or water pump belt
- Gear lubricant
- Cabin lights, courtesy bulb number GE94 or GE90
- WD-40 (rust inhibitor)
- Navigation light bulb number GE-90 or GE1004
- Dome lights number GE-1141
- Propeller nut and washer
- Drive pin, if required
- Spare propeller
- Fuse numbers—AGC10/12/15/30

2. Instruct passengers in the use and location of life jackets and fire extinguishers.
3. Check your self-contained head. It should be charged with a fresh chemical solution before starting a trip.
4. Check your water system. It should be filled and the operation of the manual or pressure pump should be tested. On those models with a pressure system, there is an off/on switch located in the galley that activates the pressure pump. Your pressure pump system has a switch in the galley area that activates the pressure pump. When your water tank runs dry, you should shut off the pump as continuous running when dry will damage the pump.
5. Bilge pumps work well if their intakes are kept clear of debris and the outlet hose is kept free. Occasional checking of operation is advised. Don't run your pump dry. Add a little water to the bilge and pump out to make certain it is operating properly.

Trailer

Before using trailer provided with Bayliner boat, read trailer owner's manual thoroughly.

1. Purchase a trailer with the proper capacity rating. A trailer that is sprung to carry more weight will ride too roughly and can damage your boat. Too little trailer capacity will be unsafe on the freeway, and will not meet legal requirements.
2. Consult your state laws as to brake requirements, and check brakes for proper operation prior to departure on each trip.
3. Check tires for proper inflation. Under-inflated tires heat up rapidly and tire damage is likely to occur.
4. Wheel bearings should be checked at least every 90 days and before putting your boat away for the season.
5. When on a trip, make it a habit to check the wheel hubs every time you stop for gas or refreshments. If the hub feels abnormally hot, the bearing should be inspected before continuing your trip.
6. Your boat should be fastened to the trailer by a line from the bow eye to the winch line PLUS a safety chain or cable to the winch stand or trailer tongue. The stern of your boat should be tied down to the trailer from the stern eyes.
7. Check to be sure the taillights and turn signals work when attached to the towing vehicle. Some automobiles require heavy duty flasher units to make turn signals work properly.
8. Your trailer should support your new boat in as many places as possible and be adjusted so the load is well divided among the supporting rollers or pads. Occasional lubrication of the rollers aids in launching and retrieving your boat.

9. Too much or too little tongue weight will cause difficult steering and tow vehicle sway. A rough rule of thumb is 5% to 10% of boat and trailer weight on the tongue.
10. Close and secure all cabin windows and doors. Store equipment so that it cannot slide or fall.
11. **IMPORTANT: Convertible tops are not designed to stay on boats at highway speeds. Before towing, take down the convertible top, side curtains and back cover. They can be damaged.**
12. Check springs and under carriage for loose parts.
13. Carry a spare wheel with tire to fit the trailer with tools sufficient to change it.
14. On extended trips, carry spare wheel bearings, seals and races. Due to the immersion necessary to launch your boat the trailer bearings and packing will not last the mileage they will in your auto.
15. Before backing your trailer into water, disconnect the light plug from the car. This will greatly reduce the chances of blowing out your trailer lights when they become submerged.

How to Back Up Your Trailer

We will attempt to show you how it is done in pictures. However, practice makes perfect, so we suggest using an empty supermarket parking lot for practice.

CAUTION: When backing, be sure to have a lookout; your visibility may be severely impaired. Also, make certain the rudder will clear obstacles.

1. Turn the front wheels of the car in the opposite direction from which you want the trailer to go.
2. Once the turn is started, follow the trailer as you would normally backing the car.
3. When rounding turns on highways or streets, don't cut corners.
4. Equip your vehicle with a right hand mirror, a real benefit when passing and parking.

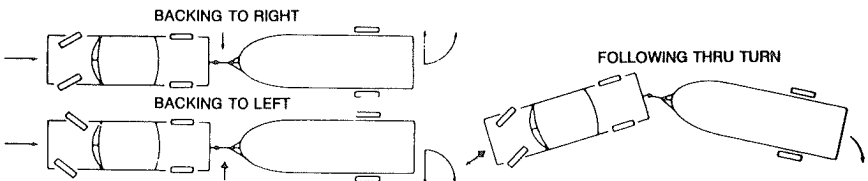

Getting Away From the Dock

Now comes the big moment. Piloting a boat is a lot like learning to drive a car. Extra caution and slow speeds cause fewer accidents. The diagram will help you to understand how your new Bayliner steers. After leaving the dock, secure and store any fenders or mooring lines.

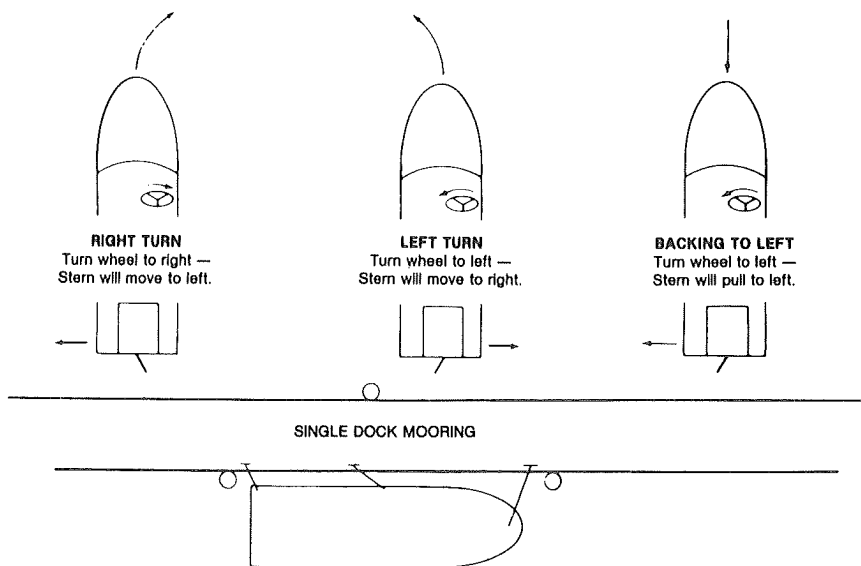

Practice Maneuvers Under Power

Once you are away from the dock, devote some time to learning how to maneuver.

1. Practice docking by using an imaginary dock.
2. Practice stopping. You have no brakes, but reverse works well at low speeds.
3. Remember your boat is heavy. When operating in close quarters or docking, all maneuvering should be done at idle speed. Proceed with caution in congested areas. Deep-V boats do not track straight at slow speeds. Proceed with caution in congested areas.
4. Gradually increase your speed. Get used to the boat before any full throttle operation.

Docking

Proper docking begins with proper preparation. Start by making sure you have adequate equipment, and that it is stowed correctly and ready for use. Your dealer is the best source for the amount and type of equipment you should carry.

1. Attach lines to deck cleats by making a loop in one end, large enough to pass through hole in the base of cleat and back over entire cleat. Pull line tight. Done this way, the line will not come off the cleat. The line now can be used to secure your boat. Lines may be kept this way while running as long as they are coiled and cannot become fouled in gear or props. In heavy sea conditions, all lines should be removed from decks.

TIP: Tie up by running line from boat, around dock cleat, and back to boat. This way you can untie without jumping from deck to dock and back aboard. Just cast off one end and then bring the whole line on board.

2. Be aware of wind, tide, current or other forces that effect your direction when leaving the dock and account for this in your maneuvering. Most maneuvering to and from a dock is best accomplished at 600 to 800 r.p.m.

When approaching a mooring situation where there is a wind, tide or current, try to use these elements to your advantage. Allow them to carry the boat into dock. If there are high winds or strong currents, it is best to approach the moorage from the lee side. With a mild current or little or no wind it is best to approach from the windward side. When approaching check to see that all lines are attached to the cleats on the side that you will be mooring and that fenders are lowered on that side. Be sure to check that the fenders are hung at the proper height.

3. **SINGLE SCREW BOATS:** When leaving a mooring on your starboard side and your bow cannot be pushed away from the dock first, start forward with wheel to starboard in idle for 2' or 3'. Then shift to reverse with steering full to port. Repeat if necessary to get the stern far enough away from the dock so you can back clear of any other boats that may be moored ahead of you. (Reverse wheel directions when leaving port docking.)

NOTE: Most anchoring and mooring areas have restricted speeds; as a matter of common boating courtesy, watch your wake.

4. **TWIN SCREW BOATS:** The same procedure should be followed with the exception of maneuvering the boat away from the dock. For dual engines you have a choice of swinging the bow or the stern out away from the dock. If the mooring is to your starboard side (right) for the bow to be moved away from the dock, the starboard engine should be in forward and the port engine in reverse at the same r.p.m. This will give you a counterclockwise rotation. When maneuvering the bow

out first you should watch to see that your swim platform and/or dinghy won't be forced into the dock or a piling. Another maneuver to pull away from the dock is done by moving away stern first. This is done with the starboard engine in reverse, the port engine in forward and using a bumper between the bow and the dock as a pivot point. The stern will then move away from the mooring far enough so the engine can be reversed and the bow brought out away from the dock. Both engines can then be switched forward and steering started when the boat becomes parallel with the mooring and clear of other objects.

NOTE: When maneuvering with twin engines, control is best accomplished by shifting with the engine throttles at idle. The out-drives or rudders should be straight fore and aft.

When approaching a mooring area, lower your speed within a reasonable distance to allow your wake to subside before it reaches other boats or docks. As you get close to your moorage check the wind and any tide current action that may affect your maneuver and make a conservative approach with these factors in mind.

5. **SINGLE SCREW BOATS:** When possible, as you approach your mooring it is desirable to have a person on the bow and the stern of the boat with a boat hook and a mooring line attached to a cleat. When approaching on the starboard side, approach at idle r.p.m. in forward at approximately 45 degrees to the dock. When your craft is 1/2 to 1/4 of a boat length away, turn hard to port, and stern will swing into the mooring. Now turn to starboard and at idle r.p.m. put the boat into reverse. This will stop the boat and bring the stern even closer to the dock. At this time, the boat can be put into neutral.
6. **TWIN SCREW BOATS:** Approach the dock in the same manner as a single screw boat. When the bow is within a few feet of the dock (starboard side) the stern can be brought alongside the mooring by reversing the port engine, starboard engine in forward. These procedures are reversed for docking to port.

Section II

Parts and Systems—Operations and Maintenance

Electrical Systems

Although Bayliner manufactures many different model power boats the electrical systems on all models operate on the same basic theory. The key to a good marine electrical system is the battery. The batteries on Bayliners 1400 through 2860 are a dealer installed item. Bayliner makes the following recommendations on battery rating:

The 1400 through 2860—minimum 70 amp/hour rating (4 Cylinder I/O and Outboard).

Models 1950 through 2860—minimum 85 amp/hour rating (8 Cylinder I/O).

Models 2450 through 2860—minimum 105 amp/hour rating (Diesel Powered).

In addition Bayliner recommends, as an added safety factor, that all models 2150 - 2860 be equipped with an extra starting battery and a vapor proof battery selector switch. Consult your dealer about this option.

On all models 3250 - 3870 the batteries are part of the standard equipment supplied by Bayliner. Gas powered models are equipped with one 85 amp/hour battery and one 105 amp/hour battery. The 85 amp/hour battery is used for starting and ignition on both engines and is charged by the port engine. The 105 amp/hour battery is used for accessories and is charged by the starboard engine.

Each battery is connected to a vapor proof OFF/ON battery switch. The isolating of the charging circuit on the starboard engine is accomplished through a special alternator exciter circuit. This circuit is fused in line (AGC 10 amp) adjacent to the main battery switches. The fuse is marked "battery charger" and is not to be confused with the 110V battery charger. The exciter circuit is activated by an oil pressure controlled switch on the starboard engine. When the starboard engine is started, the oil pressure comes up, the pressure switch closes, the exciter circuit is energized and the alternator charges the accessory battery.

On the 3870 Model three on-off battery switches and two batteries are provided. A 225 amp/hour battery is used for starting and ignition on both engines and is charged by the port engine. A 225 amp/hour battery is used for accessories and is charged by the starboard engine. The third battery switch is a cross over switch between the start and accessory battery and is used to start the engines if the start battery goes dead. The cross over switch should be turned on only in emergencies. It should not be left on. Leaving this switch on can result in all onboard batteries being exhausted.

On those models 2150 through 2860 the condition of the battery can be read on the volt meter when the ignition is in the "ON" position. On

models 3250 through 3870 the condition of the main starting battery can be read on the volt meter marked "ENGINE CIRCUIT", when the engine battery switch and the port ignition switch are in the "ON" position. The condition of the accessory battery can be read on the volt meter marked "ACCESSORY CIRCUIT" when the accessory battery switch is in the "ON" position. The starboard ignition switch does not have to be on to read the accessory battery condition.

With the engine(s) not running, volt meter readings in the 11.5 to 12.5 volt ranges are considered normal. Readings in the 10 to 11.5 volt range indicate a marginal charge condition. Readings below 10 volts indicate a serious discharge condition.

With the engines running (over 1,500 r.p.m.) volt meter readings of 13 to 14 volts are considered normal. Readings below this indicate a severely discharged battery or a non-functioning charging system.

Battery

The marine battery has a big job; it supplies you with lights, engine starting power and power to run many accessories. Don't neglect it! Check the water level regularly by removing the caps. If the zinc plates are exposed, add distilled water. Corroded battery terminals can also let you down. Clean them with baking soda and water, and coat them with a preservative or a light film of grease. Be sure all battery connections are tight. When storing the boat, it is best to remove the battery, give it a full charge, and store it inside where there are not extreme temperatures.

Fuses and Circuit Breakers—12V

On all inboard/outboard powered models 2150 through 2860 the engine and accessory circuits are protected by a large circuit breaker located on the engine(s): 40 amp. In addition, the power tilt motors on all Volvos are protected by a 20 amp fuse AGU (20).

On all inboard/outboard or inboard powered models 3250 through 3870 the engine circuit(s) are protected by a large circuit breaker located on the engine(s): 40 amp (Volvo and USM Diesel) - 25 amp (Chrysler Diesel). The accessory circuits are separate from the engine circuit(s) and are protected by a large circuit breaker (70 amp) located at the main battery switches. The ignition circuits on all inboard and inboard/outboard powered models are protected by an AGC 12 amp fuse located on the back of the instrument panel in an in-line fuse holder at the ignition switch or in the main fuse block. On the outboard models the accessory panel is protected by an AGC 20 amp fuse in-line fuse holder at the battery.

1650 - 2860 Standard Equipment—Fuse blocks on these models are located behind the instrument panel (at both stations on bridge model boats). The fuses are marked as to which accessory they protect. AGC 10 amp fuses are used on all standard equipment accessories.

The standard equipment on the 2750, 2850 and 2860 models includes

a pressure demand water pump (fresh water system), a sump pump (shower) and a 110V/12V refrigerator. The power for these accessories is taken off the back of the instrument panel and the fuses are located there.

2110-2860 Optional Accessories—Electric hydraulic trim tabs; the power taken directly off battery and is fused in-line at the battery (AGC 20 amp).

Electric refrigerator—The 12 volt power for this accessory is taken off the fuse block (AGC 10 amp).

Spotlight—The power for this accessory is taken off the instrument panel where the remote control is located. There are two in-line fuses at the remote control. The motor drive for the light is protected by an AGC 1.5 amp fuse and the light by an AGC 10 amp fuse.

Hot water cabin heater—The power for the hot water cabin heater is taken off the main fuse block behind the instrument panel (AGC 10 amp).

Electronics—The stereo, C.B. radio and depth sounder are fused at the main fuse panel with an AGC 10 amp fuse. These items are also individually fused. See electronic owner's manual for details.

Macerator Pump—Macerator holding tank discharge pumps are fused at the main fuse panel with AGC 20 amp fuses.

3250 - 3870 Standard Equipment—The fuses for these models are located on the face of the instrument panel, except model 3270, which has two fuse blocks behind the instrument panel. All fuses used are AGC 10 amp with the exception of the blowers and bilge pumps, which use AGC 15 amp fuse and cabin lights which use AGC 15 amp fuses. The main power supply for the accessories is protected by a 70 amp circuit breaker which is located at the main battery switch(es). Also located at the main battery switch(es) are in-line fuses for the accessory battery charging circuit and the automatic switch for the bilge pump. The main battery switch panel is located in the engine compartment. On the 3250 models, the blower and Volvo drive lift controls are fused in-line behind the instrument panel and receive power from the engine circuit.

3250 - 3870 Optional Accessories—All accessories are fused at the instrument panel with the exception of the power windlass. This accessory has its own control switch panel and is protected by a 150 amp circuit breaker. The shower sump pump shares a fuse with the demand fresh water pump. The spotlight, trim tabs and stereo have their own fuses and the hot water cabin heater and holding tank pump are fused to the two extra accessory fuses.

Dockside Power

Listed below are those models 2450 through 3870 equipped with 110V dockside power as standard or optional equipment.

<u>Model</u>	<u>Dockside STD/OPT</u>	<u>Dockside Cord Lght/Adpt</u>	<u>Breaker Box Location</u>
2450 Ciera Sunbridge	OPT	50'/30amp	Galley Face
2450 Ciera Command Bridge	OPT	50'/30amp	Galley Spice Rack
2550 Ciera Designer's Edition	STD	50'/30amp	Aft End of Galley
2750 Ciera Sunbridge	STD	50'/30amp	Aft End of Galley
2850 Contessa Designer's Edition	STD	50'/30amp	Hanging Locker Top
2850 Contessa Command Bridge	STD	50'/30amp	Lower Helm
2860 Trophy Cuddy	STD	50'/30amp	Cabin Cabinet
3250 Conquest Sunbridge	STD	50'/30amp	Galley Spice Rack
3270 Motoryacht	STD	50'/30amp	Lower Helm
3870 Motoryacht	STD	50'/30amp	Lower Helm

The 110 volt circuit breakers are marked as to which accessory(s) they protect. In addition to the individual breakers, all models are equipped with a main breaker. On those models 2850 through 3870 equipped with a generator, dual 30 amp inlets or air conditioning, two main circuit breakers are supplied.

The main circuit breaker(s) is located at the top of the circuit breaker panel. With the dockside power cord plugged in and all the breakers in the "ON" position, the 110 volt accessories on the boat can be used.

NOTE: A phase test warning light is installed on each panel. When connecting to shore power the phase tester should be checked to see that the shore power is in phase with the boat. An out of phase condition can result in electrical shock. It is also recommended that 15 amp and 20 amp adapters be purchased for the 30 amp cord. Not every shore installation has 30 amp service.

The simultaneous operation of several 110V accessories i.e. electric stove, electric heat, refrigerator, etc. can result in an overloaded 110 volt circuit on the boat or on the shore. It might be necessary to shut one accessory off while operating another.

All models with a 110 volt receptacle in the head are equipped with a ground fault interrupter to protect users from electric shock. This device will protect other labeled outlets also.

110V/12V Refrigerator

The Norcold refrigerator used by Bayliner operates on 110V AC and 12V DC power. When the 110V system is not hooked to an AC source, the refrigerator operates on 12 volts. When an AC source is supplied, by a generator or dockside power, the refrigerator automatically switches to 110V.

The refrigerator is the heaviest continuous draw on the 12 volt system. While operating, the refrigerator draws 8 amps. If no other 12 volt accessories are used, the refrigerator can draw a 100 amp battery dead in less than 24 hours. For this reason it is recommended that when operating on 12 volts, the cold setting on the refrigerator should not be set higher than position 2. It is also advisable to turn the refrigerator off at night. If you are going to be out more than one day and cannot connect to dockside power or do not have a generator, you should plan to run the main engine(s) each day to keep the battery(s) up.

NOTE: It is recommended that the owner's manual supplied by the manufacturer of this equipment be read before operating the equipment.

Hot Water Heater (Fresh Water System)

On the 2450 - 3250 models equipped with standard or optional hot water heater, the heater is hooked up to the 110 volt dockside power system only. If the engine is equipped with fresh water cooling, either optional or standard, the hot water system heater may also be plumbed to the engine cooling system.

On the 3270 - 3870 models, the hot water heater operates on 110 volts and is also plumbed to the main engine cooling system. Hot water from the engine cooling system circulating through a heat exchanger in the hot water tank will heat the water in the tank. The hot water tank which holds approximately 6 gallons is equipped with a thermostat and a reset button.

CAUTION: When operating the hot water tank on 110 volts, if the water supply runs dry, the hot water tank must be shut off immediately or the 110 volt heating element will burn out.

NOTE: It is recommended that the owner's manual supplied by the manufacturer of this equipment be read before operating this equipment.

Generator 3250 - 3870

To operate the generator the following procedure should be followed:

1. Check the oil level.
2. Check to see that seawater valve is open.
3. Open fuel valve.
4. Inspect engine and bilge for fuel leakage. Do not start engine if any fuel is present.

5. Operate blower for 4 minutes.
6. Turn generator switch to start. When generator starts, turn the A.C. source selector to "Generator".

NOTE: It is recommended that the owners manual supplied with the generator be read before operating the equipment.

Battery Charger 2450 - 2860

On these models with dockside power, an automatic battery charger is provided. This charger is normally connected to the main power lead at the fuse block behind the instrument panel. If a battery selector switch is installed the battery charger output should be reconnected to the common terminal of this switch or no charging will occur when the switch is OFF.

Battery Charger 3250 - 3870

All 3250 - 3870 models are equipped with an automatic battery charger. The battery charger operates when the 110 volt dock side power is connected and the battery charger circuit breaker is on. On those models equipped with a generator, the battery charger operates when the AC source selector switch is on "Generator", the generator is running, and the battery charger circuit breaker is on. The battery charger will charge the batteries regardless of the battery switch position. The battery charger has two isolated outputs and charges both batteries simultaneously, as required.

Schematic Wiring Diagram

1400 Capri and 1410 Trophy

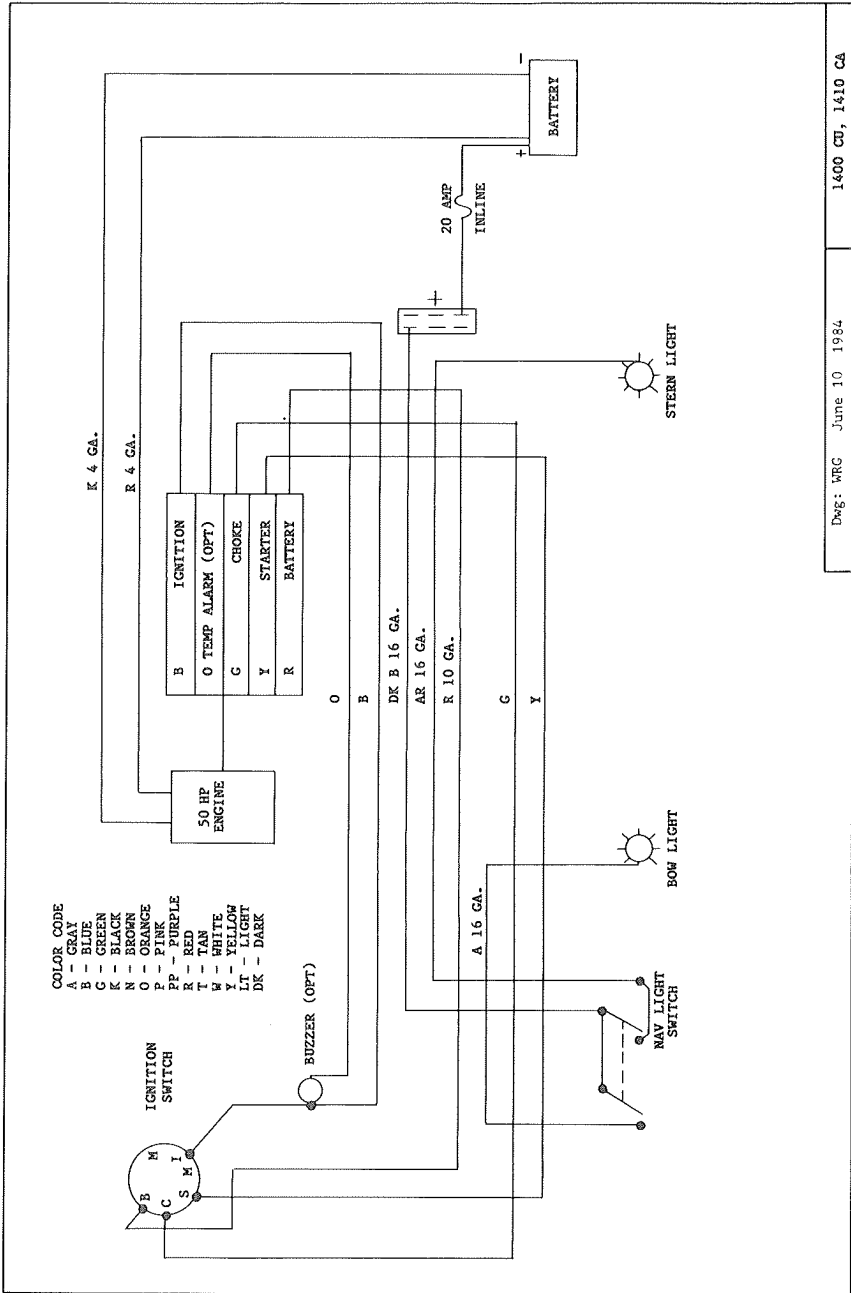

1400 CU, 1410 CA

Des: WRC June 10 1984

Schematic Wiring Diagram

1710 Trophy

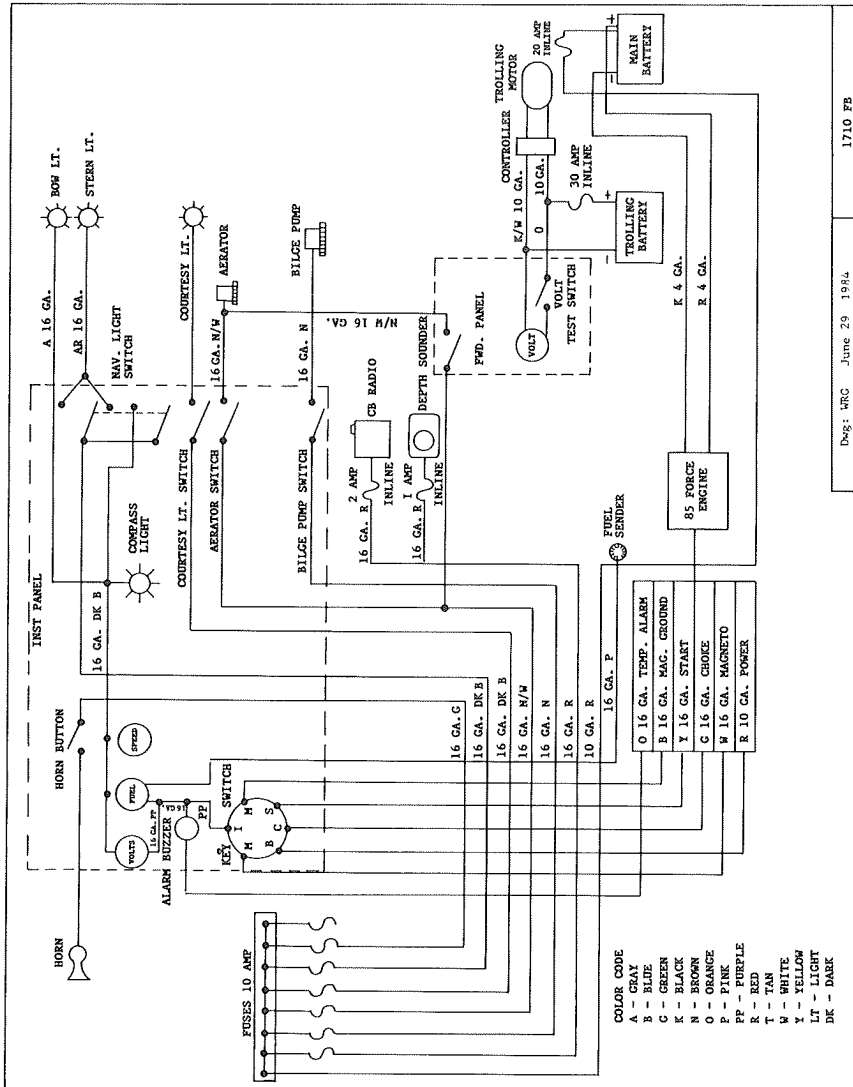

Schematic Wiring Diagram

Model 3870

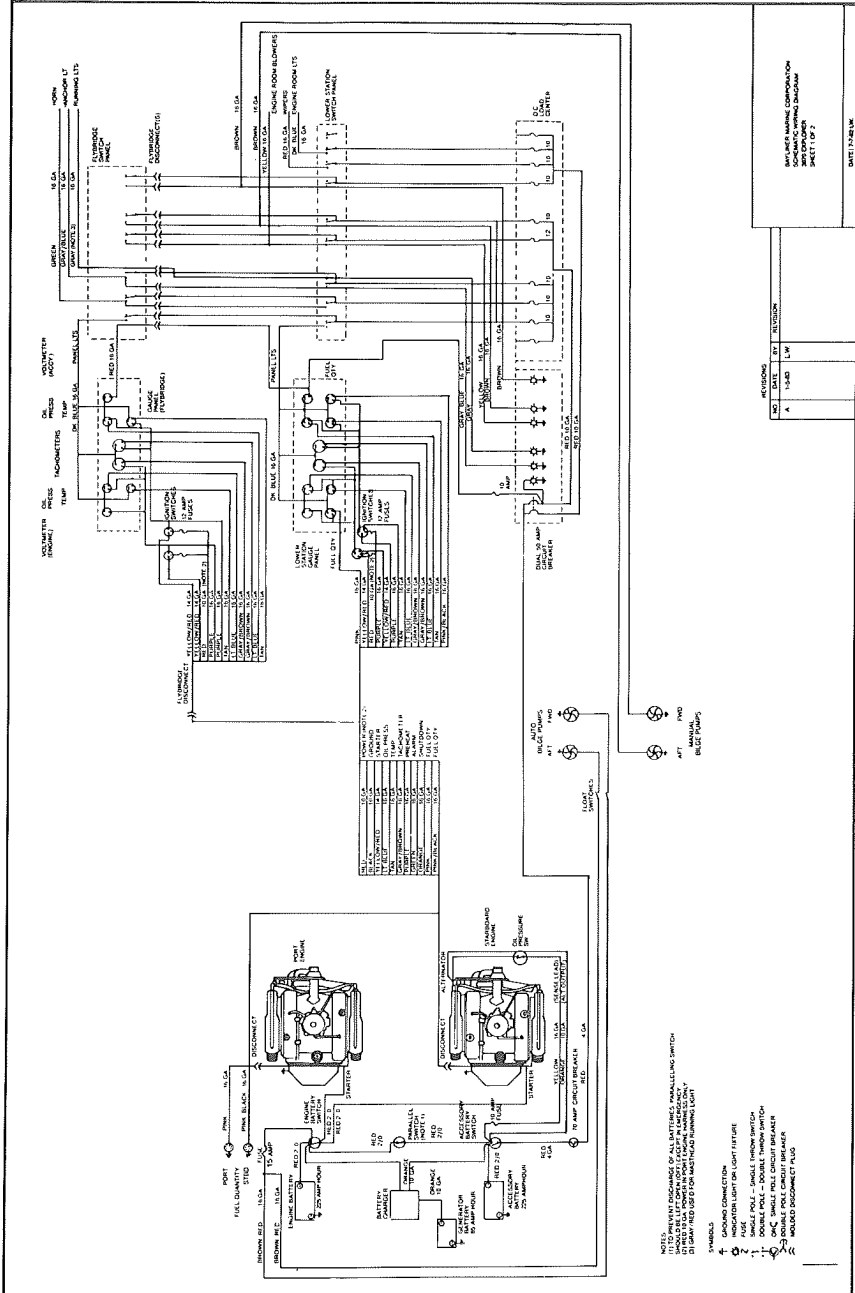

Fuel Systems

CAUTION: It is very important that the fuel system be inspected thoroughly at the time it is first filled and then at each subsequent filling. We recommend for your safety and the safety of your passengers that the “fueling” instruction in Section I of this manual must be followed.

1. *Fuel Fills and Vents:*

Fuel fills are located either on the aft deck or on the side decks adjacent to the aft cockpit and are marked “Fuel” or “Gas”. Fills are located so that fuel spilled from the fill will flow overboard. Fuel vents are normally located in the hull or transom below and in the same general area as the fill. If you experience difficulty filling the fuel tank, you should check to see that the fuel fill and vent lines are free from obstructions and kinks.

2. *Anti-Siphon Valves:*

As required by the U.S. Coast Guard, the fuel systems on all gas powered boats manufactured by Bayliner are equipped with an anti-siphon valve. This valve is an integral part of the barb fitting on the fuel tank to which the neoprene fuel line attaches. The valve is spring loaded and is opened by fuel pump pressure. These valves will prevent gasoline from siphoning from the fuel tank in the event of a fuel line rupture.

CAUTION: If an engine running problem is diagnosed as fuel starvation, the anti-siphon valve should be checked. In the event the valve is stuck or clogged it should be cleaned or replaced with engine off. Under no circumstances should it be removed except in an emergency.

3. *Fuel Filters:*

All fuel tanks installed by Bayliner are equipped with a fine mesh screen filter on the fuel pick-up tube in the tank. In addition, when supplied by the motor manufacturer, an additional filter is installed on the engine. Fuel filters should be checked periodically to see that they’re clean and free of debris.

4. On those models 3270 - 4550 equipped with inboard engines, two fuel tanks are used. The fuel lines from these tanks are run to a manifold made up of two OFF/ON valves and a crossover valve. If the boat is equipped with the optional generator there is also a valve on the manifold for the generator fuel line. Under normal conditions, the boat should be run with the main valves open and the crossover valve closed. If for some reason one of the tanks runs dry, the valve to that tank can be shut, the crossover opened and both engines run off the tank with fuel. When running two engines off one tank, you should not run the engines in excess of 3,000 r.p.m. The fuel manifold is located inside the aft cockpit hatch.

CAUTION: Avoid the storage or handling of gear near the fuel lines, fittings and tanks.

5. Diesel Fuel:

The diesel fuel systems utilized in Bayliner boats are similar in many ways to the gas system. Diesel engine operation requires a return fuel line from the engine to the tank. Thus, the fuel system has two lines between the engine and the tank instead of one. The diesel fuel tanks are not fitted with anti-siphon valves. Fuel valves are included in diesel systems between the tank and engine and on the return line. In some applications a crossover valve is used. Fuel filters are utilized in every diesel installation. It is very important that the filters be checked and cleaned regularly.

FUEL CAPACITY TABLE

<u>Model</u>	<u>Power</u>	<u>Tank No.</u>	<u>Capacity (gallons)</u>
2150 Ciera Sunbridge	I/O	7535	54
2450 Ciera Sunbridge	I/O	7536	64
2450 Ciera Command Bridge	I/O	7501	70
2550 Ciera Designer Edition's	I/O	9541	105
2750 Ciera Sunbridge	I/O	8139	124
2850 Contessa Designer Edition's	I/O	7207	120
2850 Contessa Command Bridge	I/O	6878	129
3250 Conquest Sunbridge	I/O	4318	205
3270 Motoryacht	I/B	Port 7135 Stb 7136	100 100
3870 Motoryacht	I/B	Port 7312 Stb 7311	152 152
4550 Pilothouse Motoryacht	I/B	Port 9399 Stb 9400	250 260
2160 Trophy Cuddy	I/O	9393	65
2460 Trophy Cuddy	I/O	7901	92
2860 Trophy Cuddy	I/O & I/B	8162	144

Freshwater System

The freshwater systems in Bayliner cruiser models vary in tank size and location.

Manual pumps work on a push-pull basis.

FRESH WATER LOCATION AND CAPACITY

<u>Model</u>	<u>Pt.No.</u>	<u>Location</u>	<u>System</u>	<u>Water Fill Location</u>	<u>Capacity (gallons)</u>
2150 Ciera Sunbridge	3915	underliner midship	hand pump	on the tank	13
2450 Ciera Sunbridge	P-324	port-engine box	hand pump	port-deck aft	21
2450 Ciera Command Bridge	P-324	port-engine box	hand pump	port-deck aft	21
2550 Ciera Designer Edition's	P-324	under-salon sole	demand pump	stb-side aft	21
2750 Ciera Sunbridge	324	port-engine box	demand pump	port-deck aft	21
2850 Contessa Designer Edition's	7826	V-berth	demand pump	bow-deck	30
2850 Contessa Command Bridge	3469	under cabin sole midship	demand pump	stb-deck midship	36
3250 Conquest Sunbridge	4341	engine room sole	demand pump	port-deck aft	45
3270 Motoryacht	4474	under cabin sole	demand pump	stb-deck midship	75
3870 Motoryacht	7313	under galley sole	demand pump	stb-deck midship	86
4550 Pilothouse Motoryacht	9401	upper V-berth	demand pump	bow-deck	125
	9702	lower V-berth	demand pump		75
2160 Trophy Cuddy	3915	underliner midship	hand pump	stb-deck midship	13
2460 Trophy Cuddy	8188	underliner midship	hand pump	stb-deck midship	26
2860 Trophy Cuddy	8894	under aft berth	demand pump	port-deck midship	30

Pressure systems operate at any time the electrical switch is on. When not using the boat, or when tank is dry, be sure the switch is off. Pressure pump switches are located in the galleys on all models. On those models with showers, the shower sump switch is located in the head. Because the shower floor is below the waterline, a sump pump must be used to remove shower water.

Starter Motor

The engine starter motor is different from most 12V electric motors. It is designed to deliver high horsepower for very short intervals only. Avoid operation for more than 30 seconds at one time. Due to its high horsepower this motor builds up considerable heat and can be permanently damaged with prolonged use. If it does not operate, check battery for charge and all direct connections for shorts or loose connections. The starter motor is located very near the bilge of your Bayliner. If bilge water is allowed to accumulate to a depth of more than 6", the starter can be damaged. Automatic bilge pumps are recommended for boats left in open moorage.

Bilge Blower

The bilge blower is designed to draw fumes out of the engine compartment and causes fresh air to circulate into the compartment through the deck vents.

The bilge blower is designed to be used before starting the engine(s), during starting and while boat is operating below cruising speed, to insure fresh air circulation. Operate blower for 4 minutes before starting engine.

WARNING: The blower will not prevent explosion. If you smell any fuel, shut off all electrical accessories and engine and investigate immediately.

Bilge Pump

The electric bilge pump supplied with your Bayliner is of an impeller type. If you see water and the pump motor is running but not pumping, check to see that it is not clogged by debris. If it still does not pump, check the discharge hose for kinks or a collapsed area.

NOTE: The federal water pollution control act prohibits the discharge of oil or oil waste into or upon the navigable waters and contiguous zone of the United States if such discharge causes a film or sheen upon, or discoloration of, the surface of the water, or causes a sludge or emulsion beneath the surface of the water. Violators are subject to penalty of \$5000.

Running Lights

If failure occurs, check the following:

1. You may have blown a fuse. (Replace fuse in switch panel.)
2. The bulb may be burned out. (Carry spare bulbs for replacement.)
3. The bulb base may be corroded. (Clean periodically as required and coat with non-conductive grease or vaseline.)
4. A wire may be loose due to vibration or mis-stowed gear. (Repair where break occurred.)

NOTE: Prolonged operation of cabin interior lights (overnight) will result in a dead battery. Be conservative in the use of battery power.

Windshield Wiper

The wiper motor supplied with your Bayliner, like all good equipment, requires some maintenance. Do not increase the size of the wiper arm. The manufacturer has engineered the motor for that exact load. If the wiper does not operate: 1) Check the fuse, 2) Check the switch, and 3) Make sure wiper arm is securely attached to motor.

Head Operation

MARINE HEAD WITH HOLDING TANK (OPTIONAL)

The marine head with holding tank is designed so waste may be flushed into the holding tank or, for those traveling offshore and beyond Federally regulated waterways, flushed overboard. This is accomplished by routing the head discharge hose through a "Y" connector to the holding tank and also overboard. There are valves in each of these lines. To flush waste overboard the gate valve to the tank must be closed and the thru-hull seacock should be open. To flush into the holding tank, close the through-hull seacock and open the gate valve to the holding tank. To empty the holding tank the boat must be taken to a pump out station.

To operate the marine head, open the seacock on the seawater intake. Before using, pump some water in to wet the bowl. After using, pump until thoroughly cleaned. Pump a few more times to clean lines. If excess waste should cause water to rise in bowl, stop pumping till water recedes. If at any time you are unable to pump water into the bowl, the probable reason is debris sucked into the pump diaphragm. To remedy, shut inlet seacock and dismantle pump. Pump is generally held together with six screws. The design is simple and the problem will be obvious when pump body is split open. To winterize toilet, shut off intake valve. Pump until dry. Remove drain plug in base and pump again to remove all water. Do not use antifreeze. The inlet seacock should be closed while the boat is underway or when the boat is left moored in the water.

Portable Heads

NOTE: Use only white toilet tissue as colored dyes may impair the effectiveness of the chemical. Use regular ply tissue. Do not use disintegrating tissue as this may clog the entire pump system.

NOTE: There are many brands of toilet chemicals, any of which will work very well in any of the portable toilets supplied by Bayliner.

1. PASSPORT

Be sure to read and carefully follow manufacturer's instructions.

a. *To Fill Fresh Water Tank:*

Remove upper section from lower section. Remove fill cap and fill to maximum water line on side of tank. **DO NOT OVERFILL.**

b. *To Flush:*

PULL holding tank flush valve handle straight out. To rinse bowl, stroke the pump several times. Next, "slowly" push valve handle straight in. This will ensure a leakproof seal.

c. *To Add Chemical Deodorizer:*

Pull flush valve handle straight out so bowl clapper seal is completely open. Add 2 oz. of Liquid Gold® concentrate or Royal Gold® powder directly into tank. Pump sufficient water through bowl opening to cover bottom surface of lower tank.

NOTE: Do not add holding tank chemical to upper fresh water tank.

NOTE: Do not add odor control chemical into bowl with bowl clapper seal closed.

Before use, always check the pressure build-up by pulling out the flush handle slowly with the lid closed.

Before using, it is necessary to pump liquid into the basin. Keep the basin dry when running.

d. *Cleaning:*

Use only mild cleansers, detergents or soaps. Avoid using abrasive cleaners and clean the toilet periodically as you would your own household toilet.

e. *To Empty:*

To empty the portable model into another toilet, remove the pour-spout cap in the middle rear side and connect the hose adapter with an adequate length of three inch (7.62cm) flexible sewer hose clamped on to submerge the hose below the waterline in an existing toilet bowl.

Gradually tilt the unit to drain out.

After emptying, flush a half pail of clear water into the holding tank and swirl contents to rinse out. Repeat if necessary.

f. *Cold Weather Usage:*

Add a non-toxic winter protector anti-freeze to the fresh water supply tank to prevent freezing.

g. *Storage:*

Empty water tank and holding tank. Rinse out holding tank.

2. VIP 3

Be sure to read and carefully follow manufacturer's instructions.

a. *To Fill Fresh Water Tank:*

Remove the water fill cap located at the rear right hand corner of upper unit. Add water to maximum fill level indicated on side of the water tank. DO NOT OVERFILL.

b. *To Flush:*

To add water to bowl before using, operate hand pump in an up and down motion. To flush, pull holding tank valve handle at front of toilet straight out and stroke pump once or twice to rinse bowl. To close and seal holding tank, slowly push valve handle in all the way.

c. *To Add Chemical Deodorizer:*

PULL open holding tank valve and pour chemical through bowl into waste holding tank. Pump water into tank to cover bottom of tank.

NOTE: Do not add holding tank chemical to upper fresh water tank.

NOTE: Do not add odor control chemical into bowl with bowl clapper seal closed.

d. *To Empty:*

Empty when contents of bottom tank are within 1 inch below bowl clapper seal. Detach unit from floor. Remove upper water tank. Lower unit may now be carried to permanent toilet facility. Unscrew holding tank cap in a horizontal position. Slowly tilt to empty. If necessary, rinse out with clear water and replace cap. Reattach tanks.

e. *Cleaning and Maintenance:*

To clean the toilet use a mild bowl cleaner, soap or cold water detergent. Avoid using abrasive cleaners or wire brushes.

f. *Cold Weather Usage:*

Add a non-toxic winter protector anti-freeze to fresh water supply tank to prevent freezing.

g. *Storage:*

Empty water tank and holding tank. Rinse out holding tank.

HOLDING TANK AND VALVE LOCATION TABLE

<u>Model</u>	<u>Pt. No.</u>	<u>Cap. (gal.)</u>	<u>Location of Hold. Tank</u>	<u>Location of Inlet Seacock</u>	<u>Location of Discharge thru Hull</u>	<u>Location of Y-valve</u>
2150 Ciera Sunbridge (SJ)	3195	13	stb side engine well	stb side under dinette seat	stb side aft	on the holding tank
2450 Ciera Sunbridge (SB)	3195	13	stb side engine well	stb side under dinette	stb side aft	on the holding tank
2450 Ciera Command Bridge (SC)	3195	13	stb side engine well	forward side engine well	stb side aft	on the holding tank
2550 Ciera Designer Edition's (ST)	3195	13	stb side engine well	forward side engine well	stb side aft	on the holding tank
2750 Ciera Sunbridge (SG)	3195	13	aft side engine well	forward side engine well	stb side transom	on the holding tank
2850 Contessa Designer Edition's (CD)	3195	13	stb side aft berth access	head compartment	stb side midship	stb side aft berth access
2850 Contessa Command Bridge (CM)	3195	13	port side beneath dinette	beneath cabin sole thru access hatch	beneath cabin sole thru access hatch	beneath dinette thru access hatch
3250 Conquest Sunbridge (CB)	3195	13	stb side engine well	under head access	stb side aft	stb side aft access
3270 Motoryacht (EK)	3195	13	beneath salon stb side access	beneath salon stb side access	beneath salon stb side access	beneath salon stb side access
3870 Motoryacht (EL)	3469	36	beneath forward cabin sole	beneath galley sole	behind galley stb side	beneath galley sole
4550 Pilothouse Motoryacht (EM)	9678	48	under aft head sink	under forward shower	aft head access	aft head access
2160 Trophy Cuddy (FD)			N/A	N/A	N/A	N/A
2460 Trophy Cuddy (FG)			N/A	N/A	N/A	N/A
2860 Trophy Cuddy (FH)	3195	13	aft of head under mid berth floor	aft head bulkhead	stb side midship	aft of head head under berth floor

ALCOHOL STOVES (pressurized)

The alcohol stove supplied with your Bayliner is the finest available. Read carefully and follow the operating instructions. Use only stove alcohol labeled specifically for marine use. Do not operate stove while underway.

To Fill:

Unscrew filler cap. Fill tank with denatured alcohol using a funnel. Replace cap. The filler cap is equipped with a safety valve and must not be replaced by any other type of cap.

To Start:

Pump approximately 20 times to pressurize fuel tank. Pump is located at front of stove.

To Operate:

Burners must be preheated to produce vaporized alcohol. Slowly open one burner at a time to allow alcohol to flow into priming cup below the burner body. Fill priming cup 3/4 full (about 1/4 oz). Shut off burner and ignite priming alcohol. When this alcohol is fully consumed, turn control knob toward open position and light burner.

CAUTION: All alcohol spilled while filling tank or as a result of priming cup being filled to overflowing should be cleaned up prior to lighting alcohol stove. Follow starting instructions above carefully. Flare-up may occur during preheating, particularly if burner valve is opened before preheating is completed. If flare-up occurs, shut off burner and restart per instructions. DO NOT PUT COOKING UTENSILS ON STOVE UNTIL BURNERS ARE FUNCTIONING PROPERLY.

To shut off burner, turn control knob to the extreme right and then release pressure in tank by loosening filler cap.

ALCOHOL STOVES (non-pressurized)

Read carefully and follow the operating instructions. Use only denatured stove alcohol. Do not operate stove while underway.

To Fill:

Open the stove. Lift the cutting board away if used. Close both burners. Slacken the retaining screw in the middle of the front completely. Pull the top forward (against you) to enable the pegs to disengage at the rear of the stove. Lift the top at the middle of the grid to ensure that it is kept horizontal while raised.

Tank must not be filled near an open flame or hot object. The stove top must only be lifted when the burner openings are completely covered by the regulating plates (burners closed). Lift out tank unit. It is essential that not only has the flame been completely extinguished, but that there is no heat glow on top of the tank.

During use, the tanks are heated and the fuel requires space to expand. It is therefore important to avoid overfilling the tanks.

The tank openings are recessed to facilitate filling. Hold the tank with the recess pointing down, and pour the fuel directly into the opening covered by the wire mesh. Check quantity by raising to vertical. When fuel is visible in recess, do not fill more.

After filling, make certain no excess fuel remains in stove. Always wipe tanks dry. Place tanks in stove. Check that they fit properly in mountings.

Close the stove. Make certain that both burners are closed and proceed inversely to the opening procedure.

When the pegs fit in the holes at the rear and the top is flush with the cabinet, finish by tightening the retaining screw.

To Light:

Turn regulator counterclockwise (towards + sign) to open burner. Place a lighted match at tank opening. (Match can be dropped in and removed at next filling). If the stove is warm (from previous use), burner may ignite suddenly and simultaneously snuff itself out. If this happens, blow down into burner opening to dissipate alcohol vapor, and re-light.

Winterize your stove by burning remaining fuel.

To Extinguish:

Turn regulator clockwise (towards – sign).

Electric Alcohol Stoves

To fill, start, and operate alcohol portion of the stove, see instructions given in the above section.

Electric Stove Operation

Stove top must be down. Lift lower end of latch to unlock it. Left electric control knob operates the high speed left burner and the right control knob operates the right low speed burner. Left and right indicator lights will indicate when each burner control is “ON”. Set the knob for the heat desired. Infinite controls provide any desired heat. The burners will cycle on and off during operation. When finished cooking, be sure both knobs are “OFF” and the indicator lights are out.

Propane Stove

The propane system is a very safe and simple system. A solenoid shutoff valve has been included as standard equipment on the propane system. The shutoff valve is actuated by a switch located on the galley face. To operate, the main power switch plus the range switch on the 12V accessory panel must be on. By turning the switch off, propane is turned off instantly at the tank. It is important that the stove instructions, provided as part of the owner’s package, be read completely before operating the stove.

LOADING LIMITS: HARDTOPS, CABIN TOPS, COMMAND BRIDGES

Hardtops and cabin tops are of reinforced fiberglass. They are designed to be lightweight for proper boat balance and carry the following load limits: hardtop models (Trophy) not to exceed 100 pounds; Command Bridge Model not to exceed 500 pounds (2450); 700 pounds (2850 through 3270), 1000 pounds (3270 and 4550). **These are maximum limits for boats carrying a normal complement of fuel and gear. Boats with a lighter load should carry less weight than stated maximum in critical areas noted above.**

Transom Platforms

Weight not to exceed 250 pounds.

Auxiliary engine not to exceed 7½ horsepower (on all transoms with molded outboard brackets).

Periodically check for looseness and corrosion.

Stuffing Box Packing

1. Procedure for Packing Stuffing Boxes (Inboard Models)

a. Use correct size packing as listed:

<u>Model</u>	<u>Part No.</u>	<u>Size</u>	<u>Packing Size</u>	<u>No. Rings</u>
3270 Motoryacht	2879	1¼ "	¼ "	3
3870 Motoryacht	3029	1½ "	¾ ₁₆ "	4
4550 Pilothouse Motoryacht	3029	1½ "	¾ ₁₆ "	4

b. Wrap packing around shaft and cut rings with a razor blade at approximately 30 degrees to long axis of shaft.

c. Install number of rings listed above. Stagger ends of each ring and insure rings bottom in nut.

2. Procedure for Setting Up Packing

a. Tighten packing nut by hand only until resistance of packing contacting the stuffing box is felt. Tighten lock nut securely as shaft rotation will tend to turn the packing nut and either loosen or tighten the packing nut depending on direction of shaft rotation.

b. When initially launched the packing must be allowed to leak at a rate of about 5 to 30 drops a minute as it will expand and seal from water contact and friction heat of the turning shaft. Failure to allow this leakoff will result in packing burnout after a short period of running.

Section III

Underway Operating Instructions

While under power, check instruments frequently. They are the advance warning system that will enable you to avoid troublesome malfunctions.

Instruments

Tachometer — All tachometers are of the electric type, indicating engine revolutions per minute (r.p.m.) in 100's. On twin engine installations or dual station models, the tachometers may have a slightly different reading. This is normal.

Temperature Gauge — The temperature gauge indicates engine coolant temperature by monitoring a signal from a sending unit installed in the engine water jacket. The sender changes resistance value as its temperature changes. This changing resistance value is then measured by the instrument. When the gauge reads in the danger area, shut the engine off and diagnose the problem. A common cause of overheating is picking up a foreign object in the seawater intake. Usually, raising and lowering your outdrive will free it. Backing up in reverse gear then pulling ahead in forward gear for 10-15 feet is helpful too. On those twin engine powered boats equipped with a hot water system whereby the cooling system of one engine is plumbed through the hot water tank to heat fresh water, the temperature gauge(s) for that engine will read a different operating temperature than the other engine.

Oil Pressure Gauge — The oil pressure gauge indicates pressure by monitoring a signal from a sending unit. When gauge reads in the low pressure area, shut the engine off and diagnose the problem.

Fuel Gauge — The fuel gauge indicates fuel level. Since boats are many times exposed to rough water conditions and varying trim, fuel gauges may provide inaccurate readings at times. It is always good to keep track of your running time as a double check against an inaccurate gauge.

Hour Meter (optional) — The hour meter measures engine running time. It is an aid to maintenance and warranty requirements. The meter has a range of 10,000 hours with automatic recycle.

Boat Performance

Boat speeds are affected by a great many factors. Some such as temperature and attitude, you can't do anything about. You can affect other factors. They are:

1. *Loading:* Take with you only the necessary equipment. As you add weight to your boat it slows down. Keep weight low in the boat and balanced.
2. *Propeller:* Keep it in good repair and the correct pitch for your particular

situation. The factory standard equipment propeller may not be the best one for your particular boat and load conditions. The engine should be able to come up to its rated r.p.m. on a normally loaded boat. If the engine r.p.m. at full throttle is less than the maximum rated, try a prop of less pitch. If the engine r.p.m. exceeds the maximum rated, try a prop of greater pitch.

A slightly bent or nicked propeller will adversely affect the performance of your boat.

3. *Weeds, barnacles and other growth:* Keep your boat bottom clean. When your boat starts “growing grass” it will slow down greatly, even to the point it will not plane. Anti-fouling paint that does not contain mercury or copper is recommended. Base materials, such as copper, will accelerate electrolysis and possibly damage under water gear.

Marine growth varies from one area to another so it's best to consult your dealer for the best bottom paint for your particular area.

Boat Running Attitude

1. If your boat runs with its bow too high at cruising speeds, the following suggestions will help you lower the bow:
 - a. Move weight forward in the boat.
 - b. Adjust trim tabs. See trim tab section below.
 - c. Adjust thrust angle of engine.
 - (1) *Volvo I/O motors:* Move tilt pin in transom plate to the closest hole into the boat.
 - (2) *Boats with power trim:* Run power trim “down” or “in” position.
2. If your boat runs with its bow too low at cruising speeds (usually indicated by water coming off the hull way forward and the boat being difficult to steer—veering off course), you can raise the bow by doing the following:
 - a. Moving weight aft.
 - b. Adjust trim tabs. (See trim tab section below.)
 - c. Adjusting engine thrust angle.
 - (1) *Volvo I/O motors:* Move tilt pin out away from the transom, one hole at a time.
 - (2) *Boats with power trim:* Run power trim “out” with small adjustments.

TRIM TABS

Trim tabs are intended for corrections to boat trim on the port and starboard axis with very minor changes in pitch or fore-and-aft attitude. For major corrections, redistribute loads.

1. If tab position is unknown, when idling away from the dock, put your tabs in the full bow-up position.

2. After power is applied and boat is at cruising r.p.m., push appropriate tab button to level the boat on lateral axis. Several short touches of the tab button are recommended. Allow the boat to react to the new position of the trim tab after each touch. When installed under manufacturer's recommendation, the port button on the trim tab switch operates the starboard trim tab and vice versa.
3. Both tabs can be lowered slightly to lower bow. Forcing the bow down with tabs will cause steering difficulty and a loss of efficiency.
4. When running in a following sea, run tabs in full bow-up position.

WARNING: EXCESSIVE USE OF TRIM TABS WILL CAUSE A LOSS OF CONTROL. DO NOT USE TRIM TABS IN A FOLLOWING SEA AS THEY MAY CAUSE BROACHING OR OTHER UNSAFE HANDLING CHARACTERISTICS. DO NOT ALLOW THOSE UNFAMILIAR WITH TRIM TABS TO OPERATE THEM.

Operating Dual Station Boats

Always start the boat at the station from which you will be operating. This eliminates the possibility of having someone inadvertently turn off the ignition; also, if the engine stalls you are able to start it immediately. Remind anyone near the unattended control station to "KEEP HANDS OFF". When leaving one station to begin operating at the other, bring the boat to a complete stop and take your keys with you. Never leave the helm while the boat is underway and assume that someone else has the boat under control. If you are operating your boat from the bridge and you encounter heavy sea conditions, you should bring your boat down to an idle, point it into the sea and have any bridge passengers move down to the cabin. If sea conditions become very heavy, you should also leave the bridge and operate your boat from the lower station. Children left unattended below should be made to wear life jackets.

Steering Wheel Pressure

All stern drives can be adjusted so there is no pull on the wheel at one given speed or trim angle. We suggest your normal cruising speed. This is done by turning the trim tab on the lower unit in the direction the wheel is pulling. Small adjustments should be made until the steering has neutral torque at the speed you desire. When running faster or slower than this speed, a minimal amount of torque will be present.

Static Float Attitude

The static attitude of your boat can be affected by many variables. Optional equipment and loading of gear are the biggest contributors to a boat's listing. After launching, any new boat can be adjusted. If your boat lists to one side, store heavy items on the light side and light items on the heavy side.

Batteries have a big effect on static float attitude of a boat. Move batteries to the light side if required.

Tips for Boat Owners

1. When commissioning a new boat, do not plan an extensive trip or party until you have a shakedown cruise to make sure all equipment on your boat is functioning properly and you are familiar with its operation.
2. Use big bumpers as they will best protect your boat from floats, piers and other boats.
3. Carry adequate line properly sized to your boat. Three 30' lengths of 3/8" nylon line on models 2150 through 2750 and four 50' lengths of 1/2" nylon line on models 2850 through 3270. Four 60' lengths of 5/8" nylon line on the 3870 through 4550.
4. Install an adequate anchor or anchors.
5. Install all U.S. Coast Guard Safety Equipment.
6. Be courteous to other boats. Slow down in congested areas and watch that your wake does not damage other boats.

Boating Safety Courses

Your local Coast Guard Auxiliary or Power Squadron generally puts on a Safe Boating Class several times a year. They are very comprehensive and generally of minimal cost to you. Call your local U.S. Coast Guard Auxiliary or Power Squadron Flotilla for the time and place of the next class.

Section IV

General Maintenance and Repairs

Fiberglass Staining and Discoloration

These problems can generally be removed by many of the fine fiberglass cleansers available. However, they take elbow grease. For best results follow the manufacturer's recommendations. If the marine products are not available in your area, try the new liquid household cleaners such as 409, Ajax Liquid, Fantastik or others.

CAUTION: Household cleaners with abrasives will dull the finish on your boat. If this occurs, wax and buff area to restore the luster.

Hardware Cleaning

Use nearly any of the metal cleaners on the market today to spruce up hardware. After a good cleaning, a coat of paste wax will add greatly to its luster. All metal fittings, including dash panel, instruments, railings and hardware, should be sprayed with a rust inhibitor similar to WD-40 every three months when exposed to salt water and annually in fresh water. If not maintained on a regular basis, stainless steel railings and fittings will discolor.

Vinyl Upholstery

Use any good automotive vinyl cleaner; cleaner concentrates such as Fantastik work well also.

CAUTION: Avoid solvents and bleaches, as they may permanently damage the vinyl.

Vinyl Flooring

Use one of the liquid cleaners mentioned previously and a scrub brush. Rinse thoroughly to avoid slickness when wet.

Textured Vinyl Wall Coverings

Use a mild detergent diluted in water (1:6) and soft bristled scrub brush.

NOTE: It is recommended to test for discoloration in an inconspicuous place prior to removal of desired spot.

Structafoam Transom Platforms and Steps

These clean well with a spot remover made for rugs and carpets.

Teak

To keep teak looking fresh, it should be treated with teak oil at least twice a year (more often if exposure is severe). If the teak is in particularly bad condition, the teak oil should be rubbed in using 220 grit wet and dry sand paper.

Repairing Fiberglass, Gelcoat Chips, Gouges and Scratches

Almost unavoidable during the life of your boat is damage to the gelcoat or colored surface. This is not as serious as you might think. Repair is not costly and can be done by the novice.

1. *Scratches*: If the scratch does not penetrate the gelcoat surface, use automotive rubbing compounds. Dampen a soft rag or use a power buffer. Apply rubbing compound with plenty of elbow grease. The scratch may not disappear completely, however, its noticeability will decrease.
2. *Gouges and Chips*: To repair, simply obtain "Patch Paste" from your Bayliner dealer and follow this recommended procedure:
 - a. Clean area to be repaired of wax and oil. Acetone is a good solvent.
 - b. Use a small portion of patch paste on a piece of cardboard, mix thoroughly with the catalyst (two or three drops of catalyst to a tablespoon of paste).
 - c. Apply to pit, chip or gouge with a single edge razor blade to match the surface and the contour of the area being repaired. It's better to have an excess than not enough of the paste.
 - d. Allow to harden thoroughly. In most climates, one to two hours should be sufficient.
 - e. Shape the patch to desired thickness, using the fine wet sandpaper on a sanding block.
 - f. Finish using automotive rubbing compound in the same manner as for scratches.

WARNING: Teak oil, acetone and catalyst are hazardous materials and should be used only in well ventilated areas. Follow manufacturer's instructions only.

Special Care for Boats That Are Moored

If permanently moored in saltwater or fresh water your boat will collect growth and grass on its bottom. This will detract from the boat's beauty and greatly affect its performance. There are two methods of preventing this:

1. Periodic haulout and cleaning (about every 30 to 45 days). Use soap and water and a lot of elbow grease.
2. Paint hull below water line with good grade of antifouling paint.

IMPORTANT: Blistering can occur in the gelcoat finish below the water line on boats that are permanently moored. To protect against this possible occurrence Bayliner recommends antifouling bottom paint be applied. This should include three coats of International Paint Company's Interlux 404/414 barrier coat primer and two coats of Tri-Lux bottom paint or an equivalent. It is best and least expensive to have antifouling paint applied prior to first launching.

Underwater Corrosion

Stray current corrosion or electrolysis can best be compared to electroplating of chromium or brass, with the salt water acting as the electrolyte and the battery acting as the source of direct current.

Electrolysis can be prevented in several ways. The following are the most common causes and the simplest cures for the problem:

1. Keep a clean dry bilge. Wiring may leak a certain amount of electricity.
2. A poorly grounded zinc anode: Check ground wire, clean contact surfaces.
3. The zinc anode may be deteriorated beyond effectiveness: Replace at usually 50% loss.
4. Don't use a copper based bottom paint as it can cause electrolysis on some metal parts. If your boat is permanently moored we recommend you contact someone in your area specializing in corrosion control and have them check your boat in its moorage to see that it's properly protected.

Cabin Windows

Salt and brackish water are capable of etching and damaging glass. Keeping windows clean is the best preventive measure you may take. When cleaning, flush with plenty of fresh water.

On some Bayliner models, side windows are constructed of plexiglass. In order to keep clean and free of scratches wash with soap and water and a soft chamois cloth. Do not scrub with bristle brush or abrasives.

Window Leakage

Cabin window leakage is uncommon, but should it occur it is simple to remedy.

1. Mark the leak using a crayon or other nonpermanent marking.
2. Dry thoroughly. Sealer will not bond if moisture is present so you may have to wait for a dry day.
3. Coat area with silicone type rubber sealant.
4. Allow sealant to dry well, then check by sprinkling with a hose. (Cabin window or windshield leakage is not covered under the Bayliner warranty.)

Convertible Tops and Back Covers

Convertible tops can be cleaned using a regular vinyl cleaner. Vinyl cleaners may be obtained in grocery stores or auto parts houses. To prevent rainwater seepage at the canvas seams, a coating of Scotch Gard can be applied to the seams on the inside of the vinyl. Mildew can occur if your boat does not have adequate ventilation. Heat alone won't prevent mildew. If mildew does occur, it can be removed using a solution of hot water and Clorox (one cup of Clorox to one gallon of hot water). Brush into affected area, let set for 10 to 15 minutes and rinse with fresh water. If at all possible, the vinyl top parts of your boat should be stored indoors in a fairly warm, dry place. This will greatly extend the life of the material.

Instruments—Care and Service

Your marine instruments have been designed and constructed of the best possible materials and with proper care will give you years of trouble free operation.

When using your instruments in a salt water environment, salt crystals may form on the bezel and the plastic dial. These salt crystals should be removed with a soft damp cloth; never use abrasives or rough dirty cloths to wipe plastic parts. Mild household detergents or plastic cleaners can be used to keep the instruments bright and clean.

Section V

Winterizing

If your boating season has ended or cold weather is setting in follow these suggestions.

1. Drain the engine block and manifolds. Frozen water expands and can crack your engine. Consult your engine owner's manual for location of drains. There can be drains on the block and the manifold.
2. Consult operating instructions provided with your head (toilet) for winterizing. Drain self-contained heads.
3. Drain water tanks to avoid freezing and insure fresh taste in the spring. Be sure to drain accumulated water in the pump to avoid damage due to freezing. This is best accomplished by running the pump until empty. On those boats equipped with hot water tanks, remove the drain plug on the tank after all the water has been pumped out of the regular water tank.
4. Fuel tanks should be kept completely full so there is little air space to allow condensation, a major cause of sludge and gum that eventually creates problems.
5. Remove the marine battery from the boat. Fill the cells to proper level and store in a warm place. **DO NOT STORE ON A CEMENT FLOOR.** A fully charged battery will survive storage better.
6. Lubricate control and steering push-pull cables.
7. Clean the boat thoroughly. Coat deck hardware and other surfaces with a metallic rust inhibitor.
8. **IMPORTANT: Your boat should be stored under cover if possible. If covered storage isn't available then a temporary winter cover is recommended. A proper winter cover should keep the weather off the boat, but still provide adequate ventilation. Wrapping a boat up in a tight plastic cover can do more damage than good. Dampness and lack of air circulation provide ideal conditions for the fungi that cause mildew and dry rot.**
9. Bunk and dinette cushions may be left on board, however, they should be stored on edge with plenty of ventilation.
10. If storing on a trailer:
 - a. Now is a good time to repack wheel bearings. Your local auto service center can help you.
 - b. Block the trailer wheels off the ground to avoid tire deterioration.
 - c. Loosen stern tiedowns to avoid stress on hull.
 - d. Touch up trailer paint.

We hope the preventive measures will help make a spring get-ready less work. However, don't forget to consult your dealer as well as the engine owner's manual for engine winterizing requirements.

NOTE: Bayliner does not sell accessories or other items directly to the public due to production commitments. Our dealers normally stock many of our accessories or can supply them to you in a short time.

Your dealer will be happy to help you in any way possible.

Section VI

Propeller Recommendations

Variances in operating altitudes (highland vs. sea level) and loads can affect performance. Changing to a propeller of a different size and pitch can often compensate for the effects of increased load or altitude, and insure peak performance.

The following propeller chart lists a recommended propeller for some model and engine combinations. These recommendations are based on operation at sea level with two persons and a light load in all models 2150 through 2750. Recommendations for models 2850 through 4550 are based on sea level operation with four persons 4 and a light load.

Generally, for every 2500 feet above sea level it is advisable to decrease propeller pitch two inches from the recommendations listed.

Every attempt has been made to equip your Bayliners with a propeller that will optimize performance. Your boating needs, however, may make a difference of propeller desirable. Your Bayliner dealer can help you in the selection of a propeller best suited to your use.

PERFORMANCE SPECIFICATIONS

Model/Engine	Prop/Rotation	Max RPM	Max Cruise RPM	Pinhole Setting	
				V	OMC
2150 Ciera Sunbridge					
140 OMC	13 ³ / ₄ x 15 - R	4200-7600	3400-3600		19 ¹ / ₂ "
230 OMC	15 x 17 - R	4200-4600	3400-3600		20"
2450 Ciera Sunbridge					
225 V	15 x 19 - L	4000-4400	3400-3600	2	
230 OMC	15 x 17 - R	4200-4600	3400-3600		20"
260 V	15 x 21 - L	4000-4400	3400-3600	2	
260 OMC	15 x 17 - R	4200-4600	3400-3600		20"

PERFORMANCE SPECIFICATIONS (continued)

<u>Model/Engine</u>	<u>Prop/Rotation</u>	<u>Max RPM</u>	<u>Max Cruise RPM</u>	<u>Pinhole Setting</u>	
				<u>V</u>	<u>OMC</u>
2450 Ciera Command Bridge					
225 V	15 x 17 - L	4000-4400	3400-3600	2	
260 V	15 x 19 - L	4000-4400	3400-3600	2	
2550 Ciera Designer Edition's					
225 V	15 x 17 - L	4000-4400	3400-3600	2	
230 OMC	15½ x 15 - R	4200-4600	3400-3600		20"
260 V	15 x 19 - L	4000-4400	3400-3600	2	
260 OMC	15 x 17 - R	4200-4600	3400-3600		20"
125 V(T)	15 x 17 - L/R	4400-4800	4300-4500	2	
2750 Ciera Sunbridge					
260 V	15 x 19 - L	4000-4400	3400-3600	2	
260 OMC	15½ x 15 - R	4200-4600	3400-3600		20"
125 V(T)	15 x 17 - L/R	4400-4800	4300-4500	2	
225 V(T)	15 x 21 - L/R	4000-4400	3400-3600	2	
2850 Contessa Designer Edition's					
260 V	15 x 19 - L	4000-4400	3400-3600	2	
125 V(T)	15 x 17 - L/R	4400-4800	4300-4500	2	
225 V(T)	15 x 19 - L/R	4000-4400	3400-3600	2	
2850 Contessa Command Bridge					
260 V	12 x 19 - L	4000-4400	3400-3600	2	
125 V(T)	15 x 17 - L/R	4400-4800	4300-4500	2	
225 V(T)	15 x 19 - L/R	4000-4400	3400-3600	2	
3250 Conquest Sunbridge					
260 V(T)	15 x 19C - L/R	4000-4400	3400-3600	2	
3270 Motoryacht					
105 D(T)	17 x 16 - L/R	3800	2800		
3870 Motoryacht					
130 D(T)	19 x 18 - L/R	3150	2800		
4550 Pilothouse Motoryacht					
220 D(T)	22 x 21 - L/R	3000	2800		
2160 Trophy Cuddy					
140 OMC	13¾ x 15 - R	4200-4600	3400-3800		20¾"
230 OMC	15 x 17 - R	4200-4600	3400-3600		20¾"
2460 Trophy Cuddy					
225 V	15 x 19 - L	4000-4400	3400-3600	2	
260 V	15 x 21 - L	4000-4400	3400-3600	2	
2860 Trophy Cuddy					
260 V	15 x 19 - L	4000-4400	3400-3600	2	
225 V(T)	16 x 16 - L/R	4000-4400	3400-3600	2	
105 D(T)	16 x 20 - L/R	3000	2800		

Section VII

Recommendations for Safety

1. Fuel vapors are explosive and, being heavier than air, will settle in the lower parts of a boat. While fueling, all doors, hatches and ports should be closed, galley fires and pilot lights extinguished, smoking strictly prohibited and the filling nozzle kept in contact with the fill pipe to prevent static spark. Avoid spilling. Do not fill gasoline stoves, heaters, or lights on board. Whenever possible, portable tanks should be filled out of the boat.
2. After fueling, thoroughly ventilate all compartments and check the machinery and fuel tank areas for fumes before attempting to start the engine. Remember that the electrical ignition and starting system could supply the ignition to any accumulation of explosive vapors. Take time to be safe. Keep all lines tight and bilges clean.
3. Do not overload or improperly load your boat. Maintain adequate freeboard at all times: Consider the sea conditions, the duration of the trip, the weather and the experience of the operator. Do not permit persons to ride on parts of the boat that were not designed for such use. Bow riding and seat back or gunwale riding can be especially hazardous.
4. Keep an alert lookout. Serious accidents have resulted from failure in this respect.
5. Be especially careful when operating in any area where swimmers might be. They are often difficult to see.
6. Watch your wake. It might capsize a small craft. You are responsible and it can damage boats and property along the shore. Pass through anchorages only at a minimum speed.
7. Keep firefighting and lifesaving equipment in good condition and readily available at all times.
8. Obey the rules of the road. Neglect of this is the greatest cause of collision.
9. Always have children wear lifesaving devices. Always check those intended for young children for fit and performance in the water on each individual. Never hesitate to have "all hands" wear lifesaving devices whenever circumstances cause the slightest doubt about safety.

Personal Flotation Devices

Requirements—One Coast Guard approved personal flotation device (PFD) of suitable size for each person aboard recreational boats, including sailboats, rowboats, kayaks and canoes. New PFD's bearing Coast Guard approval are now identified by "Types I, II, III, or IV:"

Mandatory Equipment

1. Boats less than sixteen feet (16') in length and all canoes and kayaks: One (1) Type I, II, III or IV PFD for each person on board.
2. Boats sixteen feet (16') or over in length: One (1) Type I, II, or III (wearable) for each person on board and one (1) type IV (throwable) in each boat.

Type I is an approved device designed to turn an unconscious person in the water from a face downward position to a vertical or slightly backward position, and to have more than 20 pounds of buoyancy. Recommended for offshore cruising. Acceptable for all size boats.

Type II PFD is an approved device designed to turn an unconscious person in the water from a face downward position to a vertical or slightly backward position and to have at least 15.5 pounds of buoyancy. Recommended for closer, inshore cruising. Acceptable for all size boats.

Type III PFD is an approved device designed to keep a conscious person in a vertical or slightly backward position and to have at least 15.5 pounds of buoyancy. While having the same buoyancy as Type II, the Type III has a lesser turning ability to allow for a comfortable design for water activities such as water skiing. Recommended for in water sports, or on lakes, impoundments, and close inshore operation. Acceptable for all size boats.

Type IV PFD is an approved device designed to be thrown to a person in the water and not worn. It is designed to have at least 16.5 pounds of buoyancy. Acceptable for boats less than 16 feet and canoes and kayaks as a throwable device for boats 16 feet and over in length.

3. Know your fuel tank capacity and cruising range. If it is necessary to carry additional gasoline do so only in proper containers and take special precautions to prevent the accumulation of such vapor in confined spaces.
4. If you ever capsize, remember that if the boat continues to float it is usually best to remain with it. You are more easily located by a search plane or boat.

CAUTION: Some Bayliner trailerable boats contain flotation material, however, no boat is unsinkable. Therefore, personal flotation devices should be carried for each passenger in accordance with U.S. Coast Guard requirements.

5. Good housekeeping is even more important afloat than ashore. Cleanliness diminishes the probability of fire.
6. Know the meaning of the buoys. Never moor to one, it is a Federal offense.
7. Consider what action you would take under various emergency conditions such as man overboard, fog, fire, a stove-in hull or other bad leaks, motor breakdown, bad storm or collision.

8. Have an adequate anchor and sufficient line to assure good holding in a blow (at least six times depth of water).
9. Boat hooks are not required equipment but they are valuable when mooring or when needed to retrieve pets, preservers (and people) over the side.
10. Know the various distress signals. A recognized distress signal used on small boats is to slowly and repeatedly raise and lower the arms out stretched to each side.
11. Storm signals are for your information and safety. Learn them and be guided accordingly.
12. Falls are the greatest cause of injury both afloat and ashore. Eliminate tripping hazards where possible, make conspicuous those that must remain, have adequate grab rails and require proper footwear to be used on board.
13. Always have an up-to-date chart, or charts of your area on board.
14. Always instruct at least one person on board in the rudiments of boat handling in case you are disabled or fall overboard.
15. Keep electrical equipment and wiring in good condition. No knife switches or other arcing devices should be in fuel compartments. Allow ample ventilation around batteries.
16. Before departing on a boat trip, you should advise a responsible friend or relative about where you intend to cruise. Be sure that the person has a good description of your boat. Keep him advised of any changes in your cruise plans. By doing these things, your friend or relative will be able to tell the Coast Guard where to search for you and what type of boat to look for if you fail to return. Be sure to advise the same person when you arrive so to prevent any false alarms about your safety.
17. Do not test fire extinguishers by squirting small amounts of the agent. The extinguisher might not work when needed. Always follow approved instructions in checking fire extinguishers.
18. A special flag hoist (red flag with white diagonal) flown from boat or buoy means skin diving operations. Approach with caution and stay clear at least 25 yards.
19. Your local U.S. Coast Guard Auxiliary/Power Squadron generally puts on a Safe Boating Class several times a year. They are very comprehensive and generally of minimal cost to you. Call your local US Coast Guard Auxiliary or Power Squadron Flotilla for the time and place of the next class.

Section VIII

Nautical Terms

ABEAM:	Either side of the boat.
AFT:	To the rear or near the stern.
BEAM:	The width of the hull.
BILGE:	The lowest portion inside a boat (in a fiberglass boat, generally the underdeck and lower portion of the engine compartment).
BOW:	The forward portion of the boat.
CHINE:	The intersection of the sides and bottom of a V-bottom boat.
DRAFT:	Vertical distance from the waterline of boat to the lowest point of the boat.
FATHOM:	A measurement of 6 feet generally used to measure water depth.
FREEBOARD:	Vertical distance from deck to waterline.
GUNWALE:	Where hull and deck meet.
HATCH:	A covered opening in the deck.
HEAD:	Toilet or toilet room.
HELM:	Steering wheel.
KEEL:	The lowest external portion of the boat.
KNOT:	Nautical mile per hour; nautical mile is 6,076 ft.; land mile is 5,280 ft.
LEE:	Opposite from which the wind blows.
MAYDAY:	International spoken distress signal for radiotelephone.
PORT:	To the left side of the boat.
PORTLIGHT:	A hinged window in the boat's cabin.
SCUPPER:	An opening in a deck or cockpit permitting water to drain overboard.
STANCHION:	A fixed, upright post used for support (of rails).
STARBOARD:	To the right or right side of the boat.
STERN:	To the rear of the boat.
STERNDRIVE:	Inboard/outboard unit.
STRAKE:	One line of planks from bow to stern.
TRANSOM:	The vertical part of the stern.
WAKE:	Track or path a boat leaves behind while in motion.
WINDWARD:	The direction from which the wind is blowing.

Limited Warranty for Bayliner Boats

One Year Limited Warranty

Bayliner warrants to the original purchaser of its 1985 model boats operated under normal, non-commercial use in the U.S. or Canada that the Selling Dealer will repair or replace any parts found to be defective in factory materials or workmanship within one year from date of retail delivery.

What Is Not Covered

This warranty does not apply to: (1) Engines, drive trains, controls, props, batteries or other equipment or accessories carrying their own individual warranties; (2) Engines, parts or accessories not installed by Bayliner; (3) Window breakage or leaks; gelcoat finish, blisters, cracks or crazing; (4) Hardware, vinyl tops, vinyl and fabric upholstery, plastic, metal wood or tape trim; (5) Any Bayliner boat that has been altered, subjected to misuse, negligence or accident, or used for racing purposes; (6) Any Bayliner boat which has been overpowered according to the maximum horsepower specifications on the capacity plate provided on each Bayliner outboard boat; (7) Any Bayliner boat used for commercial purposes; (8) Any defect caused by failure of the customer to provide reasonable care and maintenance.

Other Limitations

THERE IS NO OTHER EXPRESS WARRANTY ON THIS BOAT. TO THE EXTENT ALLOWED BY LAW:

1. Any implied warranty of merchantability is limited to the duration of this written warranty.
2. Neither Bayliner nor the selling dealer shall have any responsibility for loss of use of the boat, loss of time, inconvenience, commercial loss or consequential damages.

Your Obligation

We require that you return your boat, at your expense, to your Selling Dealer or, if necessary, to the Bayliner factory. You will be responsible for all transportation, haul-outs and other expenses incurred in returning the boat for warranty service.

Some states do not allow limitations on how long any implied warranty lasts, so the above limitation may not apply to you. Some states do not allow the exclusion or limitation of incidental or consequential damages, so the above limitation or exclusion may not apply to you. This warranty gives you specific legal rights, and you may also have other rights which vary from state to state.

Bayliner Marine Corporation
P.O. Box 24467
Seattle, WA 98124

