

# ***Buccaneer***

**OWNERS MANUAL**

**THIS MANUAL IS THE PROPERTY OF:**

ADDRESS: \_\_\_\_\_

BOAT MODEL: \_\_\_\_\_

SERIAL NO. \_\_\_\_\_

ENGINE SERIAL NO. \_\_\_\_\_

PROP SIZE \_\_\_\_\_ PART NO. \_\_\_\_\_

IGNITION KEY NO. \_\_\_\_\_

TRAILER SERIAL NO. \_\_\_\_\_

LICENSE NO. \_\_\_\_\_

PURCHASED FROM: \_\_\_\_\_

DATE: \_\_\_\_\_

ADDRESS: \_\_\_\_\_

PHONE: \_\_\_\_\_

BOAT REGISTRATION NO. \_\_\_\_\_

STATE: \_\_\_\_\_

CURRENT PERMIT NO. \_\_\_\_\_

RADIO CALL NO. \_\_\_\_\_

INSURED BY: \_\_\_\_\_

ADDRESS: \_\_\_\_\_

PHONE: \_\_\_\_\_

POLICY NO. \_\_\_\_\_

*THANK YOU . . . .*

. . . . for displaying your confidence in us by selecting a Buccaneer Yacht. Our designers, engineers, assemblymen, and inspectors have utilized their skills to ensure that your new Buccaneer Yacht excels all other boats in its class in safety, performance, workmanship and comfort.

This manual is to help you become more familiar with your new Buccaneer. Reading it carefully will help you understand your boat better and contribute greatly to your enjoyment and safety in boating.

If your new Buccaneer needs service, its best friend is your Buccaneer franchised Dealer.

# TABLE OF CONTENTS

I. Welcome Aboard! . . . . .	3	IV. Familiarization, Trouble Shooting,	
Buccaneer Construction . . . . .	3	Repairs and Care . . . . .	19
II. Launching Check List and Safety Inspection. . . . .	4	Electrical System . . . . .	19
Before Launching or Trailering. . . . .	4	Battery . . . . .	19
A. Trailer Check List . . . . .	4	Fuel Tank . . . . .	19
B. Buccaneer Yacht Check List . . . . .	4	Outboard . . . . .	19
How to Back Up a Trailer . . . . .	5	Inboard . . . . .	19
Launching Your Boat. . . . .	6	Fresh Water System . . . . .	20
270 Rigging Instructions. . . . .	6	Starter Motor . . . . .	20
A. Rigging Specifications . . . . .	6	Bilge Blower. . . . .	20
B. Standing Rigging Procedure. . . . .	7	Bilge Pump. . . . .	20
C. Mast Tuning. . . . .	8	Running Lights. . . . .	20
D. Running Rigging Sequence . . . . .	9	Head Operation. . . . .	21
240 Rigging Instructions. . . . .	9	Potpourri. . . . .	21
A. Rigging Specifications . . . . .	9	Total . . . . .	21
B. Standing Rigging Procedure. . . . .	10	Stove . . . . .	22
C. Mast Tuning. . . . .	11	Static Float Attitude . . . . .	22
D. Running Rigging Sequence . . . . .	12	Tips for Boat Owners. . . . .	22
210 Rigging Instructions. . . . .	12		
A. Rigging Specifications . . . . .	12	V. General Maintenance and Repairs. . . . .	23
B. Standing Rigging Procedure. . . . .	12	Fiberglass Staining and Discoloration . . . . .	23
After Launching Your Buccaneer . . . . .	13	Hardware Cleaning. . . . .	23
Sails . . . . .	13	Vinyl Flooring . . . . .	23
Terminology (diagram). . . . .	14	Repairing Fiberglass, Gelcoat Chips, etc. . . . .	23
Care of Sails. . . . .	15	Scratches . . . . .	23
Getting Away From the Dock . . . . .	15	Gouges and Chips . . . . .	23
Practice Maneuvers Under Power . . . . .	15	Salt Water Special Care. . . . .	23
Fueling Safety Precautions . . . . .	16	Under Water Corrosion. . . . .	23
Outboard Models. . . . .	16	Cabin Windows . . . . .	24
Inboard Models. . . . .	16	Window Leakage. . . . .	24
Before Fueling . . . . .	16	Cockpit Dodger and Sailcovers. . . . .	24
While Fueling . . . . .	16	Keep Bilge Clean . . . . .	24
After Fueling . . . . .	16		
Discharge of Oil . . . . .	16	VI. Winterizing. . . . .	25
III. Sailing Tips . . . . .	17	VII. Boating Classes . . . . .	25
Heel . . . . .	17	VIII. Nautical Terms . . . . .	26
Weather Helm. . . . .	17	Suggestions for Safety . . . . .	27
Where's The Wind . . . . .	17	Warranty Registration . . . . .	Insert
The Jib . . . . .	17	Limited Warranty for	
The Main . . . . .	17	Buccaneer Sailing Yachts . . . . .	Back Cover
How To Use Luff Telltales . . . . .	18		
Halyard Tension . . . . .	18		
The Main . . . . .	18		
The Jib . . . . .	18		

# SECTION I

## WELCOME ABOARD

Your new Buccaneer Yacht has been designed to give you years of carefree enjoyment. Read this manual, use common sense, and your new Buccaneer will give you season after season of maximum performance with minimum effort and expense from you.

The purpose of this manual is to inform and familiarize both the novice and seasoned skipper with his new equipment. It will not tell you everything there is to know about sailing, but will assist with the operation of equipment built and supplied by Buccaneer.

### HOW YOUR NEW BUCCANEER WAS BUILT

For a better understanding of your new Buccaneer, we would briefly like to describe the construction methods and design characteristics of a Buccaneer Yacht. Buccaneer Yachts are manufactured on a station to station assembly line method (the boat moves to the worker) to minimize labor costs and assure top quality control. Component parts are preassembled in Buccaneer's own fiberglass, upholstery, and wood shops, then installed in the assembly line. This, too, allows top quality cabinet work and upholstery work to bring you a great value.

Every Buccaneer Yacht is hand laminated. Buccaneer uses only first quality fiberglass strand, woven roving and resin to ensure maximum beauty, superior strength and safety.

Hand lamination starts by using a highly polished inverted mold. Next comes the actual laminating process. First we start with Gel coat, (the actual outside finish of the boat) which is applied to the inside of the mold by a power sprayer. Next comes either fiberglass strand or roving depending on what size the boat is to be. This material is applied and is fully saturated with resin to bond the fibers into solid resilient material. All models have several layers of the fiberglass material to insure maximum strength where necessary. Vertical grain fir, balsa core and marine quality plywood is used for reinforcement, and all structural wood components are sealed in fiberglass resin or treated with preservative. Only quality rated marine hardware is used and it has been selected for strength and durability.

The keel of your Buccaneer is one piece of lead cast to conform to the shape of the fiberglass molded part. It is placed in the cavity of the hull and fiberglassed into place. The area between the lead and the cabin sole is filled with urethane expanded foam. If you were to damage the keel on impact, you probably would not leak water into the cabin area of your boat. If a severe impact is felt, you should have your boat hauled from the water to inspect for damage even if it does not leak. Any puncture of fiberglass is easily repaired.

Every Buccaneer conforms to U.S. Coast Guard Safety standards and has approved, solid expanded foam flotation and has foregone rigid testing for flotation, stability and seaworthiness.

The precision process of building a Buccaneer Yacht, while highly mechanized and efficient, is still time consuming. Buccaneer takes pride in its yachts and wishes you season after season of carefree enjoyment.

*Foam 320*

## SECTION II

### LAUNCHING CHECK LIST AND SAFETY INSPECTION

This section is to help you establish operating and safety procedures that will prevent problems in the use of your boat.

#### BEFORE LAUNCHING OR TRAILERING:

##### A. TRAILER

1. Purchase a trailer with the proper stated capacity. A trailer that is sprung to carry too much weight will ride too rough and can damage your boat. Too little trailer capacity will be unsafe on the highway.
2. Consult your state laws as to brake requirements.
3. Check tires for proper inflation. Under inflated tires heat up rapidly and tire damage is likely to occur.
4. Wheel bearings should be checked every 90 days and before putting your boat away for the season.
5. Your boat should be fastened to the trailer by the bow eye and the winch line PLUS a safety chain or cable to the winch stand or trailer tongue. The stern of your boat should also be tied down to the trailer.
6. Check to be sure the tail lights and turn signals work when attached to the towing vehicle. Some automobiles require heavy duty flasher units to make turn signals work properly.
7. Your trailer should support your new boat in as many places as possible and be adjusted so the load is well divided between the supporting rollers or pads. Occasional lubrication of rollers aid in launching and retrieving your boat.
8. Too much or too little tongue weight will cause difficult steering and towing vehicle sway. A rough rule of thumb is 5% of boat and trailer weight on the tongue.
9. Close and secure all cabin windows and doors. Store equipment so that it cannot slide or fall.
10. When towing, take down the cockpit dodger. It can be damaged.
11. Check springs and under carriage for loose parts.
12. Carry a spare wheel and tire to fit your trailer and tools sufficient to change it.
13. On extended trips, carry spare wheel bearings and seals. Due to the immersion necessary to launch your boat, bearings and packing will not last the mileage they will in your auto.

##### B. BUCCANEER YACHT

1. Secure mast to center area of bow and stern pulpits, protect with padding. It is safest to tow your Buccaneer with the rudder removed, it is the lowest part of the boat and could be damaged by hitting the road when steep inclines are encountered.
2. Inboard models: inspect engine and engine compartment.
  - a. Cooling water drains should be closed if the boat is new or has been stored.
  - b. All hose and drive belts should be checked for wear and adjustment. Loose belts wear rapidly.
  - c. Inspect battery connection and water level in battery. The terminal should be kept clean. Battery should be charged before laying up the boat for storage.
  - d. Examine bilge areas for fuel or lubricating oil leaks for maximum safety. Repair leaks before operation.
  - e. Check crank case and transmission for proper lubricant levels.
3. Secure mooring lines to boat.

4. Check to be sure you have the following on board:
  - a. fire extinguisher
  - b. life preservers — one for each person on board
  - c. boat hook or paddle
  - d. fenders
  - e. lines
  - f. chart for intended operation area
  - g. flashlight
  - h. flares, night and day types
  - i. small tool box with:
 

Phillips head screw drivers	ratchet, sockets and extension
slot head screw drivers	feeler gauges
pliers, visegrip	lubricating oil
regular open end wrenches	battery jumper cables
electrical tape	water pump pliers
jack knife	friction tape
allen wrenches	hose clamps
hacksaw	assorted screws, bolts, nuts and washers
hammer	water proof matches
  - j. spare parts:
    - spark plugs for outboard engine
    - drive pins
    - propellor
    - propellor nut
    - gear lubricant
    - WD-40
    - Navigation light bulb GE-90
    - Dome light bulb GE-1141
    - Shackle
    - Sheet block
    - Sheet
5. Instruct passengers in the use and location of life jackets and fire extinguisher.
6. Check your self contained head. It should be charged with a fresh chemical solution before starting a trip.
7. Check your water system, it should be filled and the operation of the manual or pressure pump should be tested. Your pressure pump system has a switch in the galley area that activates the pressure pump. When your water tank runs dry, you should shut the pump off as continuous running when dry will damage the pump. The pressure water system is equipped with a filter between the water tank and the pressure pump. This filter should be changed every two years or oftener if fresh water supply is not clear.
8. Bilge pumps work well if their intakes are kept clear of debris and the outlet hose is kept free. Occasional checking of operation is advised. Don't run your pump dry, add a little water to the bilge and pump out with the pump to check.
9. It is preferable to step your mast before launching the boat if overhead clearance will permit. **CAUTION:** Overhead wires may carry high voltage and extreme caution should be used to keep your mast away from wires at all times. (See Section III for rigging instructions)

## HOW TO BACK UP A TRAILER

We will attempt to show you how it is done in pictures. However, practice makes perfect so we suggest an empty supermarket parking lot can be the biggest benefit.

**NOTE:** When backing, be sure to have a lookout — your visibility may be severely impaired.

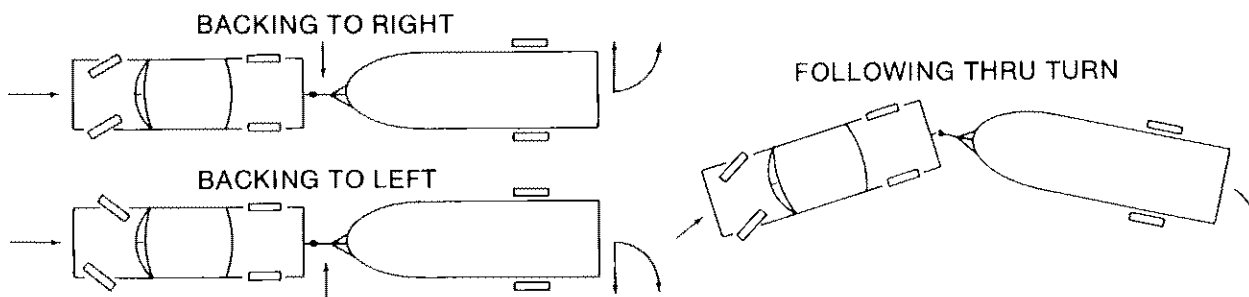

1. Turn the front wheels of the car in the **opposite** direction from which you want the trailer to go.
2. Once turn is started, follow the trailer as you would normally backing the car.
3. When rounding turns on highways and streets, do not cut corners.
4. Equip your vehicle with a right hand mirror – a real benefit when passing or parking.

## LAUNCHING YOUR BOAT

Your dealer is your best source of information on launching. There are many variables to be considered: type of trailer, fresh water, salt water, launch ramps, hoists. However, the following points should be kept in mind. When lifting your boat by straps, a spreader bar **WIDER THAN THE HULL** should be used. No bar, or one that is too narrow, could place stress on the sides of the hull causing damage. The chines and keel areas are the strongest part of your boat.

## 270 RIGGING INSTRUCTIONS

Your new Buccaneer has been carefully designed to be easily rigged by two people. Included in the rigging kit are all items necessary for setting up the boat for immediate sailing.

### A. Rigging Specifications

1. Standing Rigging
  - One forestay 5/32" 1 x 19 SS wire ~~x 21' 6 1/2"~~
  - One backstay 5/32" 1 x 19 SS wire ~~x 27' 2 1/2"~~
  - Two splitters 5/32" 1 x 19 SS wire ~~x 6' 3 1/2"~~
  - One splitter plate
  - Two Upper Shrouds 5/32" 1 x 19 SS wire ~~29' 7"~~
  - Two forward Lower Shrouds 5/32" 1 x 19 SS wire ~~x 16' 1"~~
  - Two Aft Lower Shrouds 5/32" 1 x 19 SS wire ~~48' 8"~~
2. Running Rigging
  - Main Halyard 1/8" 7 x 7 SS wire ~~x 26' 3"~~ + dacron rope tail
  - Jib halyard 1/8" 7 x 19 SS wire ~~x 16' 9"~~ + dacron rope tail
  - One main sheet 3/8" dacron
  - One jib/ genoa sheet
  - One roller furling drum and jib halyard
  - Swivel
  - One downhaul 1/4" line x 3'
  - One outhaul 1/4" line x 4'
  - Two safety wires for spreaders
  - Two snatch blocks for jib sheets
  - One block for mainsheet
  - One outhaul block
  - One roller furling line, 1/4" dacron, 48' *Approx*

*change all 210, 240, 276*

*Don't like the 270 rigging...  
 210, 240, 276...  
 100% dacron...  
 100% dacron...  
 100% dacron...*



## B. Standing Rigging Procedure

1. Make sure the area where you will be raising the mast is clear of overhead wires and obstructions.

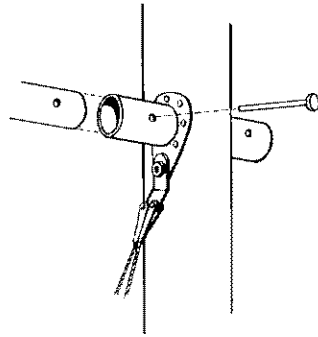

2. Slide the spreaders over the sleeve on the mast and attach them with self tapping screws. Make sure the grooves on the end of the spreaders are vertical.
3. Run the main and jib halyards through the sheaves in the masthead fitting. The jib shackle should be forward and to port, the main halyard shackle should be aft and to starboard. Secure both ends of the halyards to the cleats on the mast (this will prevent them from coming out when you raise the mast).

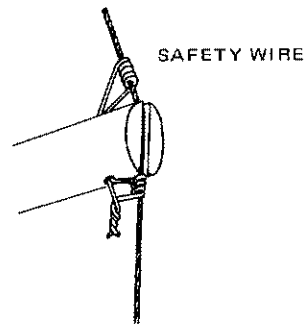
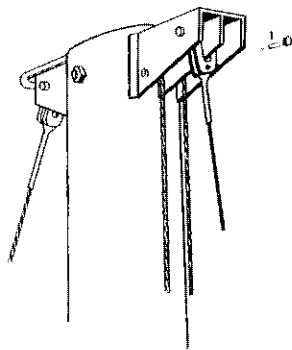

4. Attach the backstay, forestay, upper shrouds and the forward and aft lower shrouds to the mast. Safety wire the upper shrouds in the slots at the end of the spreaders. The shrouds should be able to run freely in the slots but they should be wired so they will not come out of the slots. Tape the wire end to prevent ripping or chafing of the sails.
5. Loosen the turnbuckles until four threads are showing in each end of the turnbuckle barrel. **Caution:** to prevent the turnbuckle from coming apart, insure that a minimum of four threads are showing.

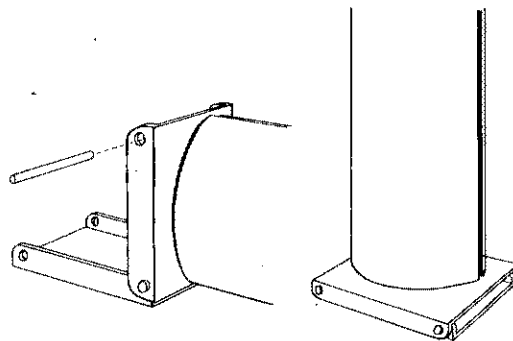
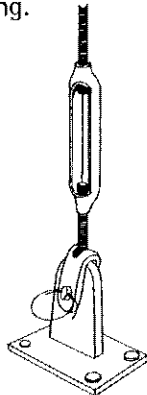

6. Position the mast so that it may be raised from aft to forward with the butt of the mast in the hinged mast step.

7. Attach the upper shrouds to the outboard hole in the chainplates. Next, attach the split backstay to after chain plates on both sides of the transom. Make sure the cotter pins (or wire cotter ring) are through the holes in the rigging pins.
8. Place the mast pin through the aft hole of the plate on the butt of the mast and the aft hole in the plate attached to the deck. Be sure to put the cotter key in the end of the pin. Raise the mast and attach the forestay, the aft and forward lower shrouds, and the forward pin in the mast baseplate.

### C. Mast Tuning

Proper tuning of your new Buccaneer will help the boat sail up to its excellent performance potential, making sailing more fun and safer.

1. Dockside tuning
  - a. Athwartship (port and starboard). Adjust the upper shrouds until the mast is straight and centered. By running a measuring tape up the jib halyard, you can measure the distance from the masthead to the chain plates on either side of the boat. Adjust the upper shrouds until the distance is equal to both sides. The upper shrouds should be firm but not tight. When pulling against them at chest height, they should move approximately 1½" to 2".

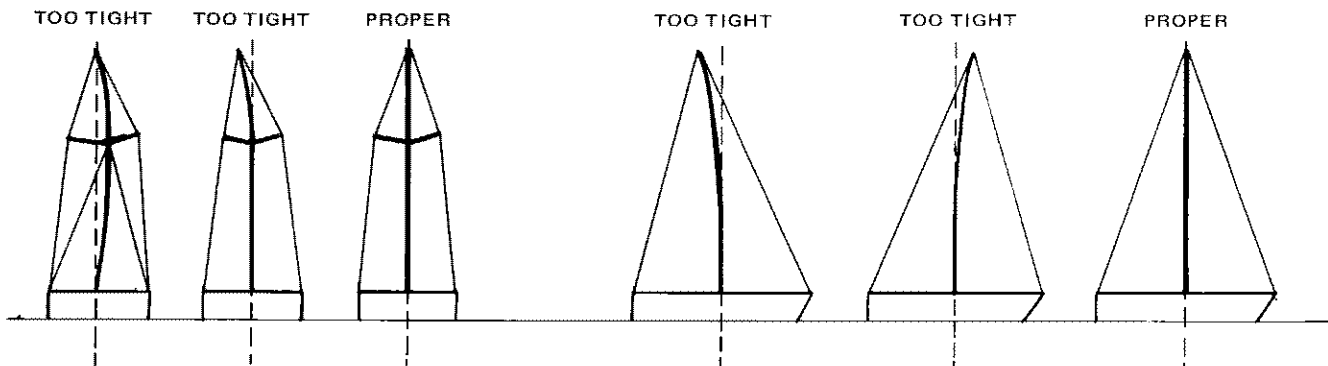

Now adjust the lower shrouds until they move from 3" to 4". Caution: Do not over-tighten the shrouds because it will not help performance and can weaken the mast by placing excessive compression loads on it. Sight up the side of the mast to make sure that it is straight.

- b. Fore and aft tuning. Adjust the forestay and backstay with equal tension until the forestay will move approximately ½" when pulled at chest height. At deck level, sight up the aft edge of the mast making sure that it is still straight.
2. Final tuning. The final tuning of the mast should take place while sailing on a close reach in winds of six to ten knots. Note: While adjusting the turnbuckles, always hold the upper sleeve to prevent unlashing the wire rigging.
    - a. Athwartship tuning. The adjusting should be done with the lower shrouds. If the mast is bowed to weather, tack and then loosen the turnbuckle. Tack again and check for straightness. If the mast is bowed to leeward, tack then tighten the turnbuckle. Repeat the procedure until you are satisfied the mast is straight to port and starboard.
    - b. Fore and aft. The primary purpose of proper fore and aft adjustment is to balance the helm. Your Buccaneer should have a tendency to point toward the direction of the wind while sailing on a close reach. This is called weather helm. To increase weather helm, the mast should be raked aft by loosening the forestay and tightening the backstay. To reduce weather helm, rack the mast forward by loosening the backstay and tightening the forestay.
  - c. After tuning your Buccaneer
    - 1) Mark all the turnbuckles so that the next time you launch the boat, it is properly tuned.

- 2) Important: Always make sure that the cotter pins are in the turnbuckles and in the rigging pins. If they aren't, it could ruin your whole day by having the mast come down.
- 3) From time to time check the mast's tuning. Even stainless steel wire rigging stretches. So keep your boat tuned; it's good seamanship and makes sailing more fun.

#### D. Running Rigging Sequence

1. Set boom in mast slot and rig. Attach topping lift ( it is a small cable attached to back stay) to the aft end of boom.
2. Mainsheet — attach eye of sheet to becket on port block. Reeve line through boom block (attached to heavy support bar), down through starboard side block, back up through boom block, down through port block and through jam cleat.
3. Jibsheet — attach the jibsheet to the clew of the genoa and reeve each end through snap blocks attached to their respective toe rail. Snap blocks should nominally be set so the sheet is on a line approximately perpendicular to the luff of the genoa.

## 240 RIGGING INSTRUCTIONS

Your new Buccaneer has been carefully designed to be easily rigged by two people. Included in the rigging kit are all items necessary for setting up the boat for immediate sailing.

#### A. Rigging Specifications

1. Standing Rigging
  - One Backstay 1/8" — 1 x 19 SS wire x 29' 0 1/4" with boom topping lift attached
  - One Headstay 1/8" — 1 x 19 SS wire x 27' -6"
  - Two Upper Shrouds 1/8" — 1 x 19 SS wire x 25' -8 1/4"
  - Two Lower Shrouds 1/8" — 1 x 19 SS wire x 14' -2 3/8"
2. Running Rigging
  - One Main Sheet — 3/8" line x 60'
  - One Jib/Genoa Sheet — 3/8 line x 60' w/snap shackle attached
  - One Downhaul — 1/4" line x 3'
  - One Outhaul — 1/4" line x 4'
  - One Main Halyard 3/32" — 7 x 7 SS wire x 23' + dacron rope tail
  - One Jib Halyard 3/32" — 7 x 7 SS wire x 24' + dacron rope tail
  - One 1 1/4" Shackle for jib tack
  - Two Safety Wires for upper shrouds — 1/16" — 1 x 7 SS seizing wire x 1'
  - Two Snap Blocks for jib/genoa sheet
  - One Boom Block
  - One Outhaul Block

*Checked  
2/29*

## B. Standing Rigging Procedure

1. Make sure the area where you will be raising the mast is clear of overhead wires and obstructions.

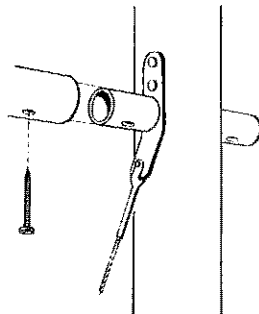

2. Slide the spreaders over the sleeve on the mast and attach them with self tapping screws. Make sure the grooves on the end of the spreaders are vertical.
3. Run the main and jib halyards through the sheaves in the masthead fitting. The jib shackle should be forward and to port, the main halyard shackle should be aft and to starboard. Secure both ends of the halyards to the cleats on the mast (this will prevent them from coming out when you raise the mast).

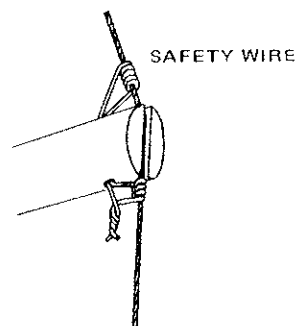
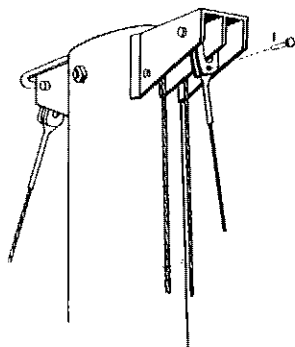

4. Attach the backstay, forestay, upper and lower shrouds to the mast. Safety wire the upper shrouds in the slots at the end of the spreaders. The shrouds should be able to run freely in the slots but they should be wired so they will not come out of the slots.
5. Loosen the turnbuckles until four threads are showing in each end of the turnbuckle barrel. Caution: to prevent the burnbuckle from coming apart, insure that a minimum of four threads are showing.

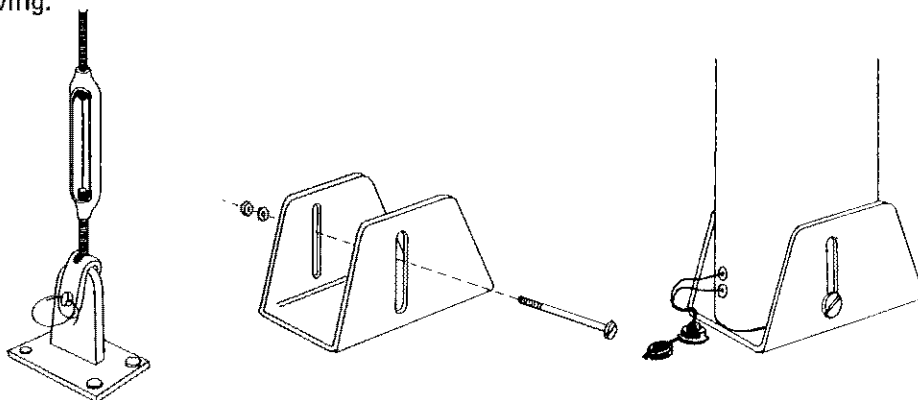

6. Position the mast so that it may be raised from aft to forward with the butt of the mast in the mast tabernacle.
7. Attach the upper shrouds to the outboard hole in the chainplates. Next, attach the backstay to after chainplate. Make sure the cotter pins (or wire cotter ring) are through the holes in the rigging pins.

8. Bolt the mast to the mast tabernacle. Raise the mast and attach the forestay and the lower shrouds.

### C. Mast Tuning

Proper tuning of your new Buccaneer will help the boat sail up to its excellent performance potential, making sailing more fun and safer.

#### 1. Dockside tuning

- a. Athwartship (port and starboard). Adjust the upper shrouds until the mast is straight and centered. By running a measuring tape up the jib halyard, you can measure the distance from the masthead to the chain plates on either side of the boat. Adjust the upper shrouds until the distance is equal on both sides. The upper shrouds should be firm but not tight. When pulling against them at chest height, they should move approximately 1½" to 2". Now adjust the lower shrouds until they move from 2" to 3". Caution: Do not over-tighten the shrouds because it will not help performance and can weaken the mast by placing excessive compression loads on it. Sight up the side of the mast to make sure that it is straight.

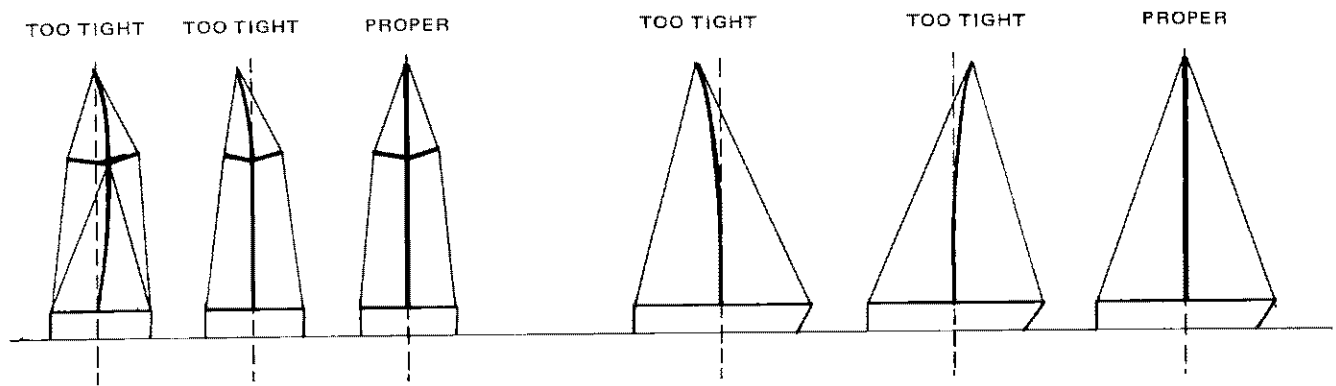

#### b. Fore and aft tuning

Adjust the forestay and backstay with equal tension until the forestay will move approximately ½" when pulled at chest height. At deck level sight up the aft edge of the mast making sure that it is still straight.

#### 2. Final tuning

The final tuning of the mast should take place while sailing on a close reach in winds of six to ten knots. Note: While adjusting the turnbuckles, always hold the upper sleeve to prevent unlaying the wire rigging.

##### a. Athwartship tuning

The adjusting should be done with the lower shrouds. If the mast is bowed to weather, tack and then loosen the turnbuckle. Tack again and check for straightness. If the mast is bowed to leeward, tack then tighten the turnbuckle. Repeat the procedure until you are satisfied the mast is straight to port and starboard.

##### b. Fore and aft

The primary purpose of proper fore and aft adjustment is to balance the helm. Your Buccaneer should have a tendency to point toward the direction of the wind while sailing on a close reach. This is called weather helm. To increase weather helm, the mast should be racked aft by loosening the forestay and tightening the backstay. To reduce weather helm, rack the mast forward by loosening the backstay and tightening the forestay.

##### c. After tuning your Buccaneer

- 1) Mark all the turnbuckles so that the next time you launch the boat, it is properly tuned.

- 2) Important: Always make sure that the cotter pins are in the turnbuckles and in the rigging pins. If they aren't, it could ruin your whole day by having the mast come down.
- 3) From time to time check the mast's tuning. Even stainless steel wire rigging stretches. So keep your boat tuned; it's good seamanship and makes sailing more fun.

#### D. Running Rigging Sequence

1. Set boom in mast slot and rig. Attach topping lift (it is a small cable attached to back stay) to the aft end of boom.
2. Mainsheet — attach eye of sheet to becket on port block. Reeve line through boom block (attached to heavy support bar), down through starboard side block, back up through boom block, down through port block and through jam cleat.
3. Jibsheet — attach the jibsheet to the clew of the jibsail and reeve each end through snap blocks attached to their respective toe rail. Snap blocks should nominally be set near the forward end of the toe rail.

## 210 RIGGING INSTRUCTIONS

Your new Buccaneer has been carefully designed to be easily rigged by two people. After you have gained experience, it will be possible to do it by yourself; however, we feel the job is easier and safer with two people.

#### A. Rigging Specifications

1. Standing Rigging
  - One forestay 1/8" 1 x 19 SS wire x 24' 10 1/2"
  - One backstay 1/8" 1 x 19 SS wire x 25' 11 1/4"
  - Two Upper Shrouds 1/8" 1 x 19 SS wire x 23' 3 1/2"
  - Two Lower Shrouds 1/8" 1 x 19 SS wire x 12' 3 3/4"
2. Running Rigging
  - Main Halyard 3/32" 7 x 7 SS wire x 19' 4 1/4" + dacron rope tail
  - Jib halyard 3/32" 7 x 7 SS wire x 19' 4 1/4" + dacron rope tail
  - One main sheet 3/8" dacron
  - One jib/genoa sheet
  - One downhaul 1/4" line x 3'
  - One outhaul 1/4" line x 4'
  - One shackle for jib tack
  - Two safety wires for spreaders
  - Two snatch blocks for jib sheets
  - One block for mainsheet
  - One outhaul block

#### B. Standing Rigging Procedure

The Buccaneer 210 is set up exactly like the Buccaneer 240. See instructions on pages 10, 11 and 12.

## AFTER LAUNCHING YOUR BUCCANEER

1. Check rigging for proper tuning. This should be done each time prior to getting underway.
2. Install rudder, attaching a safety line is advised as rudder will not float. Turn rudder to one side to fit pintles into gudgeons; the lower pintle is longer and will slip in before the upper pintle.
3. Check thru-hull fittings and hoses for leaks, tighten as required.
4. On inboard models, check engine compartment for signs or smells of fuel. Run blower for three minutes before starting, during starting and below cruising speeds.
5. On all powered boats including outboards, be sure engine is in neutral before starting. Operate engine for several minutes at dockside before casting off.
6. To familiarize yourself with the sails on your Buccaneer, it is best to hoist all sails while securely moored to a float. This should be done only in moderate or light winds. It is proper procedure to hoist sails when the boat is headed into the wind.

## SAILS

Your sails are made of Dacron, the stiff, crinkly sound is caused by filler that is added to help the sail maintain its best shape for sailing. Putting the sails on is called "bending on".

1. The **main sail** is first removed from the storage bag and the foot (bottom) of the sail is fed into the groove on the boom. The clew (the aft most corner) has a small line attached that is reefed through a pulley on the aft end of the boom and led back to the cleat on the boom. This arrangement is called a clew outhaul. It keeps the foot of your sail taut and may be adjusted for proper sail shape. Install the battens in the batten pockets. These small pieces of fiberglass help maintain proper sail shape.

The main halyard is the one on the starboard side of the mast. Fasten the Dacron part of the halyard to the starboard mast cleat; take the wire end and fasten the shackle to the head of the sail. (The head is the top point) Be sure the halyard moves easily in its block at the top of the mast and it is free of the spreaders and the jib halyard.

To raise the sail, pull down on the starboard halyard while inserting the plastic slides which are attached to the luff of the sail, into the slide track on the mast. Pull the halyard very taut and secure to the cleat. Attach a short piece of line from the boom gooseneck down to the cleat on the aft side of the mast; this is called the downhaul. The main sheet should be left with a small amount of slack; if it is too tight, you will be unable to raise the main sail properly. In light airs or with the bow into the wind, it is permissible to leave the topping life attached to the boom while raising the sail.

2. **Jib sails** come in many different sizes. Standard equipment on the Buccaneer 210 and 240 is a 100% jib which will work well in most winds. After you have familiarized yourself with sailing in strong winds with the standard jib sail, you probably will want to add a larger sail called a Genoa. We recommend a 130% or 150% Genoa. The 150% Genoa can be ordered through your Buccaneer dealer. If your area is subject to extremely strong winds, you might want to have a smaller or storm jib in your sail inventory.

The jib halyard is on the port side of the mast. Attach the Dacron line end to the cleat on port side and the wire end shackle to the head of the jib sail. Insert the middle of the jib sheet through the clew and insert both ends through the loop to form a simple hitch at the clew. The jib sheets are then lead back outside the lifeline to a snap block fastened about midships to the Genoa rail and then lead back under the lifelines to the winches. The plastic snaps on the luff of the jib are snapped to the forward stay starting with the snaps nearest to the head (top) of the sail.

Raise the sail by pulling on the port halyard. The luff of the jib should be quite taut. The jib sheets are tightened on the lee side and left loose on the windward side.

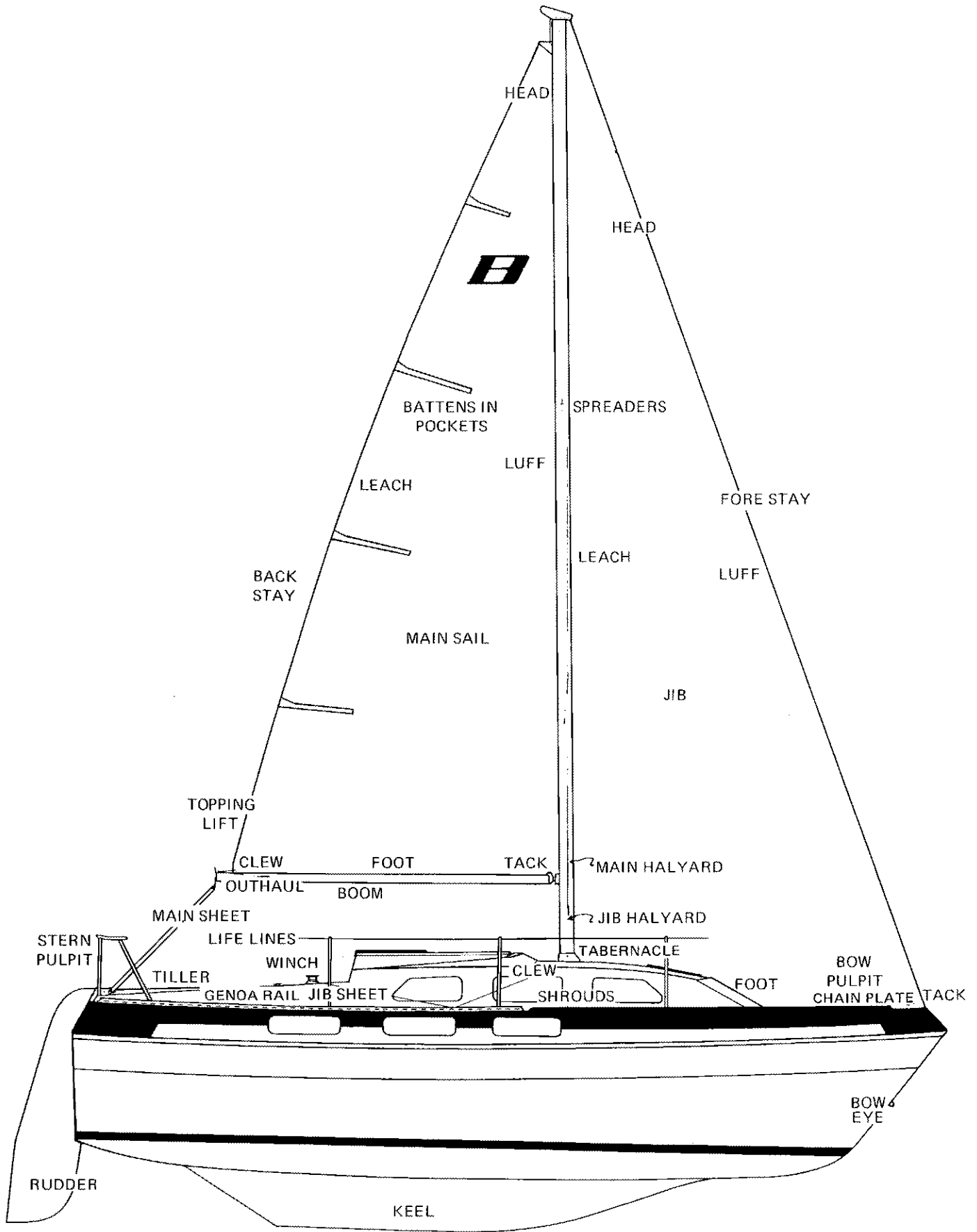



- The Buccaneer 270 comes standard with a 150% genoa and roller furling. The genoa halyard is on the port side of the mast. Attach the roller furling swivel to the halyard and to the head of the sail. The keeper rods on the swivel must be passed around the headstay. Pass the ¼" roller furling line through the hole in the top of the roller furling drum and knot the end so the knot is exposed on top of the drum. Wind the furling line around the drum until the drum is full, leaving approximately 30' of line. Pass the remaining line through the bulls-eye fairleads on the port side of the deck and secure in the cam cleat just forward of the cockpit. Attach the tack of the sail to the top of the roller furling drum with its pin and cotter key. Then attach the roller furling drum to the chain plate in a like manner. Raise the sail by pulling on the port halyard.

Insert the middle of the genoa sheet through the clew and insert both ends through the loop to form a simple hitch at the clew. The genoa sheets are led back outside the lifeline through the snap blocks fastened to the genoa rail and then led back under the lifelines to the winches.

To furl the genoa, pull the roller furling line into the cockpit. To unfurl, release the roller furling line and pull either genoa sheet.

### CARE OF SAILS

To protect sails when in use, tape or rubber protectors on turnbuckles and on tips of spreaders are recommended.

When storing sails, they will last longer if protected from sunlight, folded rather than stuffed into sailbags. To avoid mildew, sails should be stored dry. Remove sails from boat in winter or provide a small amount of dry heat to the interior of your boat. Occasional hand washing with soap and a hose will remove dirt and salt. Do not use detergents.

### GETTING AWAY FROM THE DOCK

The first few times in operating your Buccaneer it would be best to motor away from your moorage to an open, uncongested area to familiarize yourself with sailing.

Now comes the Big Moment. Piloting a boat is a lot like learning to drive a car. Extra caution and slow speeds cause fewer accidents. The following diagram will help you understand how your new Buccaneer steers. After leaving the dock, secure and store any fenders or mooring lines.

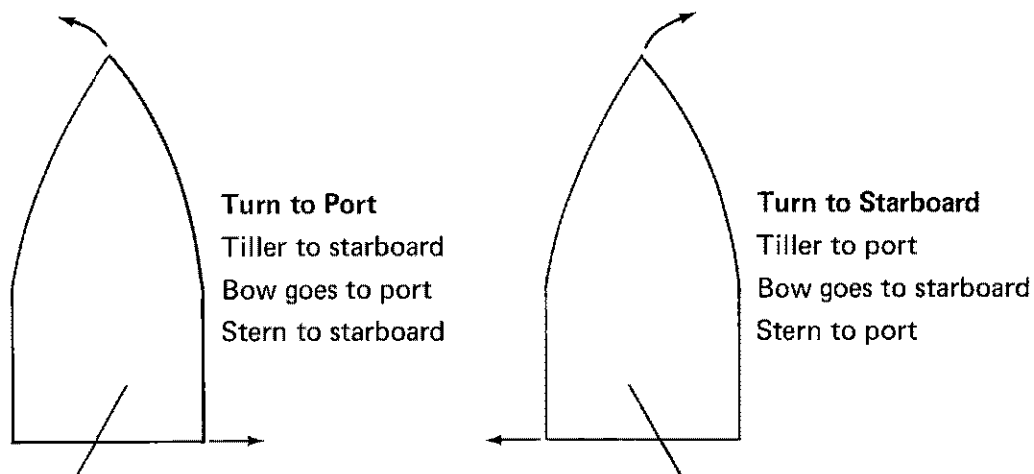

Your Buccaneer will steer well with the rudder. The motor, for most applications, can be left straight ahead.

## **PRACTICE MANEUVERS UNDER POWER**

Once you are away from the dock, devote some time to learning how to maneuver.

1. Practice docking by using an imaginary dock.
2. Practice stopping. You have no brakes, but reverse works well at low speeds.
3. Gradually increase your speed. Get used to the boat before any full throttle operation.

Have fun and stay calm. You will learn more quickly and enjoy it more.

## **FUELING SAFETY PRECAUTIONS**

- A. Outboard Models: Remove fuel tank from boat and fill on fuel dock. Wipe any spilled fuel from tank before bringing aboard.
- B. Inboard Models:
  1. Periodically check fuel tank, fill pipe, vent pipe and fuel lines for damage or loose fitting.
  2. Fueling should never be undertaken at night except under well lighted conditions.

## **BEFORE FUELING**

Whenever a boat is moored at a service station for fueling:

1. Do not smoke, light matches or lighters or throw switches.
2. Stop all engines, motors, fans and devices liable to produce sparks.
3. Put out all lights and galley fires.

## **WHILE FUELING**

1. Keep nozzle of hose or can in contact with fuel opening to guard against possible static spark.
2. See that no fuel spills get into the boat or bilge.

## **AFTER FUELING**

1. Close fill opening.
2. Wipe up all spilled fuel and wash with water.
3. Open all ports, windows, doors and hatches.
4. Permit boat to ventilate at least five minutes. Operate bilge blower.
5. See that there is no odor of fuel in the engine compartment.
6. Be prepared to cast off as soon as engine starts.

**DISCHARGE OF OIL PROHIBITED.** The federal water pollution control act prohibits the discharge of oil or oil waste into or upon the navigable waters and contiguous zone of the United States if such discharge causes a film or sheen upon, or discoloration of, the surface of the water, or causes a sludge or emulsion beneath the surface of the water. Violators are subject to a penalty of \$5,000.

# SECTION III

## SAILING TIPS

We recommend you purchase one or several of the well written books on sailing to help perfect your sailing skills. You will find many authorities on sailboats. Many have developed their skills on a particular type of boat; their expertise may or may not apply to your Buccaneer and the way you like to sail. When you get out on your boat, watch others carefully; very small changes in set and trim affect sail performance drastically.

### HEEL

Your Buccaneer is designed to sail quite upright with a minimum of heel. It will sail fastest with modest heel. In very strong winds, letting out the main and/or creating a luff at the top of the jib by moving the sheet block aft on the Genoa rail will help in keeping your Buccaneer sailing well to windward.

### WEATHER HELM

Weather helm is when the tiller must be held to windward to tack at a constant angle into the wind.

Your Buccaneer has a slight amount of weather helm in the design to provide a safety factor in that the boat will head up into the wind during a strong puff.

If the weather helm is excessive, there are several ways of correcting helm to your own personal taste.

1. Sail boat level.
2. Move weight aft (crew is easiest to move)
3. Ease main sheet; trim jib.
4. Move top of mast forward by letting out on the backstay and tightening the forestay.

### WHERE'S THE WIND

One of the most common difficulties encountered by beginners is determining where the wind is coming from. Knowing the wind direction is, of course, a necessity for proper sail trim. Here are a couple of techniques that we think will be of real use:

1. Tie pieces of knitting yarn about 6" long to the backstay and to the upper shrouds. The yarn should be tied at approximately eye level when you are standing on the deck.
  - a. These pieces of yarn are known as "telltails" and that is exactly what they do — tell you where the wind is.
2. To help you trim your sails properly while sailing to windward and while reaching, here is another hint. Sew pieces of yarn in the luff of your jib and main.

### THE JIB

1. Cut pieces of yarn approximately 12" long.
2. Starting at about  $\frac{1}{4}$  of the way up the luff and about 10" aft of the buff using a needle, push the yarn through the cloth so that 6" of yarn are on either side of the jib. Now tie small stopper knots in the yarn so that it will not pull through the cloth. Now do the same thing half way up and  $\frac{3}{4}$  of the way up the luff of the jib. (See illustration on next page.)

### THE MAIN

1. Repeat the process you used on the jib except you need do it only once, about  $\frac{1}{2}$  of the way up the luff and about  $\frac{1}{3}$  of the way aft.

## HOW TO USE LUFF TELLTALES

When sailing on a reach or to weather, trim the sails until both telltales are streaming parallel and horizontal. If the weather telltale is luffing (fluttering) the sheet should be trimmed in. If it is already trimmed in tight while sailing to weather, the helmsman should fall off slightly (sail away from the direction the wind is blowing). If the leeward telltale is luffing or hanging limp, the sails should be let out.

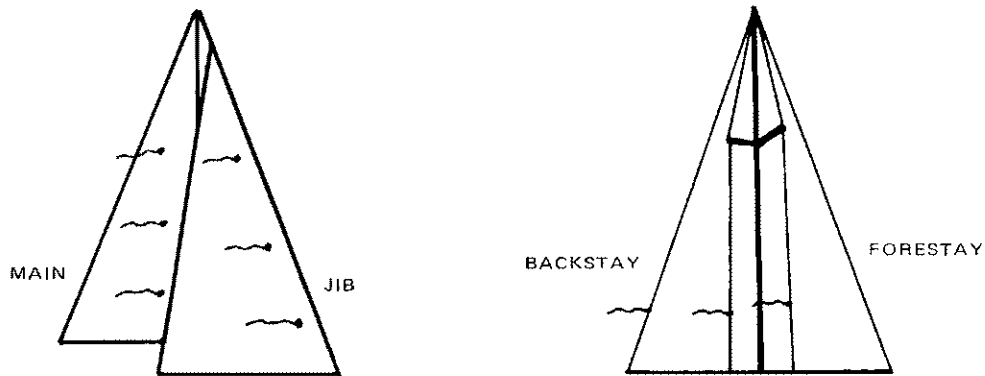

By using telltales, you will soon be sailing like an old salt. They are a big help to skipper and crew alike.

## HALYARD TENSION

Proper halyard tension plays a major role in getting the maximum performance from your sails and it is really simple to do!

### THE MAIN

Using the main halyard, pull the mainsail to the top of the mast. Now pull down firmly on the down haul removing any wrinkles (scallops) in the luff of the main. After you are sailing, use the downhaul to pull any further scallops out. The only trick is to stop just at the point where the scallops disappear.

### THE JIB

It is done just almost like the main, but to be done properly requires more adjustment with varying wind strengths. The stronger the wind, the greater the halyard tension.

Above all, don't sail with scallops in the luff of your sails. Trim those halyards. When you start passing other boats, you'll be glad you did.

# SECTION IV

## FAMILIARIZATION, TROUBLE SHOOTING, REPAIRS AND CARE

### ELECTRICAL SYSTEM

Your Buccaneer wiring is done according to the following wiring diagram.

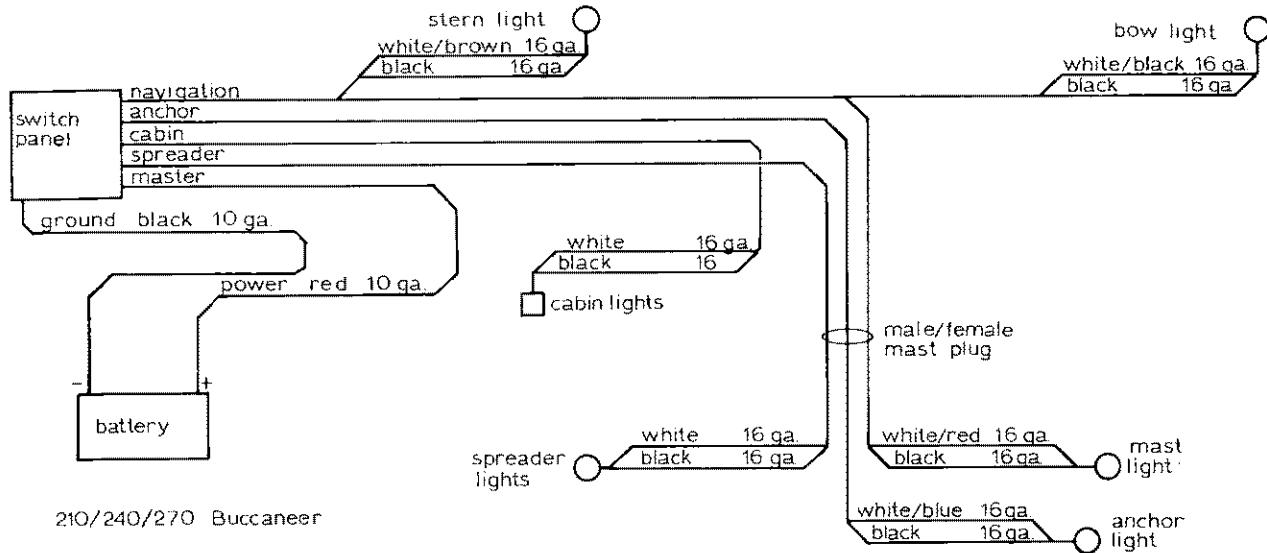

### BATTERY

The marine battery has a big job. It supplies you with lights, engine starting power and power to run many accessories. Don't neglect it!

Check the water level regularly by removing caps. If the zinc plates are exposed, add distilled water.

Corroded battery terminal can let you down. Clean them regularly with common household baking soda and water, and coat them with preservative or grease. Be sure the terminal connections are tight. A loose connection may not give you sufficient power for starting your engine. During long periods of non-use it is best to store battery in a dry area where there are not extreme temperatures. It is a good policy to charge the battery on slow charge several days before removing the boat from winter lay up.

### FUEL TANK

**Outboard:** Your outboard fuel tank should be stored in the port cockpit locker as it is properly vented.

**Inboard:** In your new inboard Buccaneer, the fuel tank is equipped with an anti siphon valve to prevent fuel from filling the bilge due to a broken line.

Occasionally contaminated fuel will cause the check valve to malfunction.

In emergency situations, the check valve may be removed if the engine is not getting enough fuel.

Do not attempt to repair the valve — replace it with a new one. During winter storage or in case of contaminated fuel, a fuel conditioner is recommended.

## FRESH WATER SYSTEM

The fresh water system in your Buccaneer may vary in tank size and location according to the model.

Manual pumps work on a push-pull basis.

Pressure systems operate at any time the electrical switch located at the tank is on. When not using the boat, or when tank is dry, be sure the switch is off.

MODEL	TANK SIZE	TANK LOCATION	PUMP TYPE
BU210	19 gallon	Under forward bunk	Manual
BU240	19 gallon	Under forward bunk	Manual
BU270	19 gallon 11 gallon	Under forward bunk Under dinette seat	Manual Pressure (for shower)

## STARTER MOTOR Inboard models only

The engine starter motor is electronically different from most motors. It is designed to deliver high horsepower for very short intervals only. Avoid operation for more than 30 seconds at one time. Due to its high horsepower this motor builds up considerable heat and can be permanently damaged with prolonged use. If it does not operate, check battery for charge and wiring system for loose connections.

## BILGE BLOWER Inboard models only

The bilge blower is a factory installed item designed to clear the bilge area of fuel fumes. In essence, it is a squirrel cage type electric fan which sucks out engine compartment air and causes fresh air to circulate into the compartment through the deck vents.

It is designed to be used before starting the engine and while the boat is operating at slow speeds to insure fresh air circulation. Operate blower for 3 minutes before starting engine.

## BILGE PUMP

The bilge pump installed under the starboard seat of your Buccaneer is of high capacity and is not only a convenience; it is for your safety. It pumps out of a sump aft of the lead in the keel. The sump should be kept clean as debris will clog any pump. If the pump does not operate properly, check for obstruction or kinks in the hoses.

## RUNNING LIGHTS

The night lights or navigation lights supplied with your Buccaneer are of top quality. However, operation failure may occur for several reasons.

1. You may have blown a fuse (Replace fuse in switch panel)
2. The bulb may have burned out (Carry spare bulbs for replacement)
3. Corroded bulb base (Clean periodically as required and coat with non-conductive grease or vasoline)
4. A loose wire due to vibration or mis-stowed gear. (Repair where break occurred)

**NOTE:** Prolonged operation of cabin interior lights (overnight) will result in a dead battery. Be conservative with use of battery power.

## HEAD OPERATION

### POTPOURRI: TO USE:

1. Mix 1½ to 2 gallons of water with four ounces of Liquid Gold concentrate and pour mixture through the opening of the basin, while operating the flushing handle on the side.
2. Pump the liquid into the basin, and push on the flush handle. Repeat the operation to assure perfect mixing.
3. Before using, it is always necessary to pump liquid into the basin.
4. Keep the basin dry when running.

**NOTE:** Use only white toilet tissue as colored dyes may impair the effectiveness of the chemical. Use regular ply tissue. Do not use disintegrating tissue as this may clog the entire pump system.

### CLEANING:

Use only mild cleaners, detergents or soaps. Avoid using abrasive cleaners. Clean the toilet bowl periodically as you would your household toilet.

### TO EMPTY:

1. To empty the portable model into another toilet, remove the pour-spout cap at the rear right-hand corner and connect the hose adapter with an adequate length of 3" (7.62 cm) flexible sewer hose clamped on to submerge the hose below the water line in an existing toilet bowl.
2. Gradually tilt the unit to drain out.
3. After emptying, flush a half pail of clear water into the holding tank and swirl contents to rinse out. Repeat if necessary.
4. To use toilet again, re-charge with ¼ bottle of Liquid Gold as done originally.

### TOTA II: TO USE:

1. Open filler cap. Fill with water to 3" from top of opening. Do not pour toilet chemical in upper pour spout.
2. Unscrew red nut. Open valve. Pull handle all the way forward.
3. Add contents of one packet of Monchem PTC Portable Toilet Chemical or Monchem T-5 through open valve into lower holding tank. Flush once or twice by operating pump up and down. Close valve.
4. During use, valve may be placed in open position or left closed to provide "wet bowl" like a household toilet. After each use, operate pump up and down to cleanse and rinse bowl.

### TO EMPTY:

1. Be sure slide valve is closed and/or red nut is tightened. Release side latches and lift upper unit off.
2. Lower unit may now be carried like a suitcase.
3. To empty through valve openings, place holding tank upside down over toilet bowl. Slowly pull trap handle all the way forward. Important: Pour spout can be utilized as an alternate method of discharge only when tank is less than ¾ full.
4. Place upper tank over lower tank. Align both tanks and engage latches. Note: No need to refill upper tank after each servicing, it has enough capacity for two complete use cycles.

## STOVE

The alcohol stove supplied with your Buccaneer is the finest available. Read carefully and follow the operating instructions. Use only blue stove alcohol labeled specifically for marine stove use. Do not operate stove while underway or during fueling operations.

**To fill:** Unscrew filler cap. Fill tank with denatured ethyl alcohol using a funnel. Replace cap. Filler cap is equipped with a safety valve and must not be replaced by any other type cap.

**To start:** Pump 20 or more times to pressurize fuel tank. Pump is located at front of stove.

**To operate:** Burners must be preheated to produce vaporized alcohol. Slowly open (counter clockwise) one burner at a time to allow alcohol to flow into priming cup below the burner body. Fill priming cup  $\frac{3}{4}$  full (about  $\frac{1}{4}$  ounce). Shut off burner (clockwise) and ignite priming alcohol. When this alcohol is **fully** consumed, turn control wheel toward open position and light burner.

**DO NOT PUT COOKING UTENSILS ON STOVE UNTIL BURNERS ARE FUNCTIONING PROPERLY.**

**CAUTION:** Flare up may occur during preheating and particularly if burner valve is opened before preheating is completed. Follow starting instructions very carefully. If flare up occurs, shut off burner and restart as per instructions.

**To shut off burner:** Turn control wheel to extreme right. Release pressure in tank by loosening filler cap.

**To clean burner nozzle:** Turn control wheel to extreme left position. This will automatically clean deposits from nozzle. Then return to extreme right.

## STATIC FLOAT ATTITUDE

The lateral stability of your boat can be affected by many variables. Optional equipment and loading of gear are the biggest contributors to a boat listing. Any new boat after launching can be adjusted to some extent. If your boat lists to one side, store heavy items on the other side and light items on the side toward the list.

Batteries have a big effect on static float attitude of a boat. Move batteries to high side if required.

On rare occasions when a list is severe, a water tank may have to be relocated.

## TIPS FOR BOAT OWNERS

1. When commissioning a new boat, do not plan an extensive trip or a big party until you have had a shake down cruise to be sure all the equipment on your boat is functioning properly and that you are familiar with its operation.
2. Use big bumpers as they will really protect your boat from floats, piers and other boats.
3. Carry adequate line properly sized to your boat. You should have a minimum of two 30' lengths of 3/8" nylon line on board. (Your dealer is a good source of advise on the proper size and length of line suitable for your boat and boating requirements.)
4. Be courteous to other boaters. Slow down in congested areas.



# SECTION V

## GENERAL MAINTENANCE AND REPAIRS

### FIBERGLASS STAINING AND DISCOLORATION

These problems can generally be removed by many of the fine fiberglass cleansers available. However, they take elbow grease. For best results follow the manufacturer's recommendations.

If the marine products are not available in your area, try the new liquid household cleansers such as 409, Ajax liquid, Fantastic or others. Caution: Household cleansers with abrasives may dull the finish on your boat. If this occurs buff the area to restore luster.

### HARDWARE CLEANING

Use nearly any of the modern chrome cleaners on the market today. After a good cleaning a coat of paste wax will add greatly to its lustre. All metal fittings, including winches, railings and hardware should be sprayed with an oil similar to WD-40 every three months when exposed to salt water and annually in fresh water.

### VINYL FLOORING

Use one of the liquid cleanser mentioned previously and a scrub brush. Rinse thoroughly to avoid slickness when wet.

### REPAIRING FIBERGLASS, GELCOAT CHIPS, GOUGES AND SCRATCHES

Almost unavoidable during the life of your boat, damage will occur to the gelcoat or colored surface. This is not as serious as you might think. Repair is not costly and can be done by the novice.

Scratches: If the scratch does not penetrate the gelcoat surface use automotive rubbing compound. Dampen a soft rag or use a power buffer. Apply rubbing compound and a lot of elbow grease. The scratch may not disappear completely, however, its noticeability will decrease.

Gouges and Chips: To repair, simply obtain "Patch Paste" from your Buccaneer Dealer and follow this recommended procedure:

1. Clean area to repair free from wax and oil. Acetone is a good solvent.
2. Using a small portion of patch paste on a piece of cardboard, mix thoroughly with catalyst. Just a few drops will do.
3. Apply to pit, chip or gouge with a single edged razor blade to match the surface and contour of the area being repaired. (It's better to have more than not enough on the patch.)
4. Allow to harden thoroughly. In most climates, 1 to 2 hours should be sufficient.
5. Shape the patch using fine wet sand paper to desired thickness, using a sanding block.
6. Finish using automotive rubbing compound in the same manner as for scratches.

### SALT WATER SPECIAL CARE

If permanently moored in salt water your boat will collect barnacles and grass on its bottom. This will distract from the boat's beauty and greatly slow its performance. There are two methods of preventing this:

1. Periodic haulout and cleaning. (About every 30 to 45 days use soap and water and a lot of elbow grease)
2. Coating with antifouling paint. A chemical toxic base — which does not contain copper or mercury — works best on fiberglass hulls. All paints require special preparation of the fiberglass finish. For best results, contact your Buccaneer Dealer or your marine paint dealer.

### UNDER WATER CORROSION, Inboard Models

Stray current corrosion or electrolysis can best be compared to electroplating of chromium or brass with the salt water acting as the electrolyte and the battery acting as the source of direct current.

Electrolysis can be prevented by several methods. The following are the most common causes and the simplest cure for the problem.

1. Keep a clean dry bilge. Wiring may leak a certain amount of electricity.
2. A poorly grounded zinc anode; check ground wire or clean contact surfaces.
3. The zinc anode may be deteriorated beyond effectiveness, replace usually at 50% loss.
4. If extremely fast deterioration is occurring, it may be wise to install electronic protection such as Mer-cathode.

## **CABIN WINDOWS**

Your cabin windows are plexi-glass like those used on light aircraft. It is best to clean them with plexi-glass cleaner. If unavailable, use generous amounts of soap and water. Do not wipe windows when dry as they could scratch.

## **WINDOW LEAKAGE**

Cabin window leakage is uncommon but if it does occur, it is very simply remedied.

1. Mark the leak using crayon or other non-permanent marking.
2. Dry thoroughly. You might have to wait for a dry day. Sealer will not bond if moisture is present.
3. Coat area with live silicone type rubber sealant.
4. Allow sealant to dry well then check by sprinkling with hose. (Cabin window or windshield leakage is not covered under Buccaneer Warranty)

## **COCKPIT DODGER AND SAILCOVERS**

To reduce mildew, occasional cleaning using automotive convertible top cleanser or household cleanser will help. Be sure to use a stiff scrub brush. Drying canvas after cleaning will also help to prevent mildew. Do not store canvas rolled up when damp. Good cockpit ventilation will also reduce the likelihood of mildew. There are also several mildew preventatives that can be sprayed on the interior of your canvas.

The areas where canvas has been stitched together will show wet and drip a little. This is normal and not harmful.

Snaps should be lubricated with WD-40 – be sure to lubricate both halves of the snap.

**NOTE:** Do not trailer boat with your cockpit dodger or sail cover up. You will bend the dodger bows, stretch the canvas, break snaps or even lose a portion of the enclosure.

## **KEEP THE BILGE CLEAN**

Trash and oil can cause bad odors and fire problems. Soap and water work best. Do not discharge oil into the water.

# SECTION VI

## WINTERIZING

If your boating season has ended or cold weather is setting, follow these suggestions:

1. Drain the engine block and manifolds. Frozen water expands and can crack your engine. Consult your engine owner's manual for location of drains. There can be drains on the block and manifolds.
2. Store boat, if outside or in an unheated area, with the bow higher than the stern to allow any condensation or water to run out.
3. Consult operating instructions provided with your head for winterizing. Drain self contained heads. Add anti-freeze to marine flushing heads.
4. Drain water tanks to avoid freezing and insure fresh taste in the spring. Be sure to drain accumulated water in the pump to avoid damage due to freezing. This is best accomplished by running the pump until empty.
5. Fuel tanks should be either completely full or completely empty. With full tanks, there is very little air space to allow condensation which causes sludge and gum that will eventually cause problems. A completely empty tank does not condensate moisture rapidly either, however, it is of greater fire and explosion hazard due to remaining fuel vapors.
6. Remove the marine battery from your boat. Fill the cells to proper level and store in a warm, dry place. Do not store on a cement floor. A fully charged battery will survive storage better. Note: It is advisable to remove the battery before draining fuel system to avoid sparks.
7. Lubricate control and steering push-pull cables.
8. Clean the boat thoroughly. Coat deck hardware and other metallic parts with a rust inhibitor.
9. If you do not have a boat cover and are storing outside, leave the cockpit dodger up. Coat the inside of snaps with vasoline or similar lubricant to avoid breakage from corrosion.
10. Bunk cushions and dinette cushions may be left aboard, however they should be stored on edge with plenty of ventilation.
11. If storing on a trailer:
  - a. Now is a good time to repack wheel bearings. Your local automotive service will help you.
  - b. Also block the trailer wheels off the ground to avoid tire deterioration.
  - c. Store in a bow high position for drainage.
  - d. Touch up trailer paint.
12. Store sails in a dry area. The sails should be clean and neatly folded to store.

We hope the above preventative measures will help make a spring get-ready less work. However, don't forget to consult your Dealer and engine owner's manual for engine winterizing.

**NOTE:** Buccaneer Yachts cannot sell directly to the public accessories or any item due to production commitments and dealer franchising. Our dealers normally stock many of our accessories or can supply you with them in a short time. Your Dealer will be happy to help you.

# SECTION VII

## BOATING CLASSES

Your local U.S. Coast Guard Auxiliary/Power Squadron generally puts on a Safe Boating Class several times a year which is very helpful to both sailboaters and power boaters. They are very comprehensive and generally of minimal cost to you. Call your local U.S. Coast Guard Auxiliary for date and location of the next class.

There are many sailing schools that will give you instruction on your boat and will help to perfect your skills. Consult your dealer for information on the schools in your area.

# SECTION VIII

## NAUTICAL TERMS

<b>Abeam:</b>	Straight out from side of boat
<b>Aft:</b>	Toward the stern or behind it
<b>Backwinding:</b>	When one sail throws wind onto lee side of another sail
<b>Bearing off:</b>	Steering more to leeward, or away from the wind
<b>Blanketing:</b>	When windward boat takes wind from leeward boat's sail
<b>Block:</b>	Sailors' term for pulley
<b>Boom:</b>	Horizontal pole along bottom of sail
<b>Bow:</b>	Front of boat
<b>Forward:</b>	Toward the bow
<b>Halyard:</b>	Line used for raising or lowering a sail
<b>Heading up:</b>	Steering more to windward, or toward the wind
<b>Heeling:</b>	When a boat leans over
<b>Knot:</b>	One nautical mile (6,080 feet) per hour
<b>Line:</b>	General term for rope
<b>Luffing:</b>	Shaking of sails that occurs when boat heads too much into the wind or sail is improperly trimmed
<b>Mast:</b>	Vertical pole supporting sails
<b>Pointing:</b>	Sailing as close into the wind as possible
<b>Quarter:</b>	Side of boat near the stern
<b>Reef:</b>	Lessen a sail's area by gathering in and tying down part of the sail
<b>Running:</b>	Sailing with the wind more or less astern
<b>Sheet:</b>	Line used in adjusting the angle of a sail to wind
<b>Stays:</b>	Wires from mast to deck, for support of mast
<b>Stern:</b>	Rear end of the boat
<b>Topsides:</b>	Sides of the boat from the waterline to the deck
<b>Trim:</b>	Adjust angle of sail to wind

## SUGGESTIONS FOR SAFETY

1. Gasoline vapors are explosive and being heavier than air will settle in the lower parts of a boat. All doors, hatches, and ports should be closed while fueling, galley fires, and pilot lights extinguished, smoking strictly prohibited, and the filling nozzle kept in contact with the fill pipe to prevent static spark. Avoid spilling. Do not use gasoline stoves, heaters, or lights on board. Whenever possible, portable tanks should be fueled out of the boat.

2. After fueling, thoroughly ventilate all compartments and check the machinery and fuel tank areas for fumes before attempting to start the motor. Remember that the electrical ignition and starting system could supply the ignition to any accumulation of explosive vapors. Take time to be safe. Keep fuel lines tight and bilges always clean. Check your fuel supply system; see that the tanks are vented outboard, that the fill pipes are located outboard of coaming and extend to near bottom of the tank. Have an adequate filter on the fuel line.

3. Do not overload or improperly load your boat. Maintain adequate freeboard at all times; consider the sea conditions, the duration of the trip, the predicted weather, and the experience of the operator. Do not permit persons to ride on parts of the boat not designed for such use. Bow riding and seat back or gunwale riding can be especially hazardous.

4. Keep an alert lookout. Serious accidents have resulted from failure in this respect.

5. Be especially careful when operating in any area where swimmers might be. They are often difficult to see.

6. Watch your wake. It might capsize a small craft; it can damage boats or property along the shore. You are responsible. Pass through anchorages only at minimum speed.

7. Keep firefighting and lifesaving equipment in good condition and readily available at all times.

8. Obey the Rules of the Road. Neglect of this is the greatest single cause of collision.

9. Always have children wear lifesaving devices. Always check those intended for young children for fit and performance in the water on each individual child. Never hesitate to have "all hands" wear lifesaving devices whenever circumstances cause the slightest doubt of safety.

10. Know your fuel tank capacity and cruising radius. If necessary to carry additional gasoline do so only in proper containers and take special precautions to prevent the accumulation of such vapor in confined spaces.

11. If you ever capsize, remember that if the boat continues to float it is usually best to remain with it. You are more easily located by a search plane or boat.

12. Good housekeeping is even more important afloat than ashore. Cleanliness diminishes the probability of fire.

13. Know the meaning of the buoys. Never moor to one – it is a Federal offense.

14. Consider what action you would take under various emergency conditions – man overboard, fog, fire, a stove-in plank or other bad leak, motor breakdown, bad storm, collision.

15. Have an adequate anchor and sufficient line to assure good holding in a blow (at least six times depth of water).

16. Boat hooks are not required equipment but they are valuable when mooring or when needed to retrieve pets, preservers (and people) "over the side."

17. Know the various distress signals. A recognized distress signal used on small boats is to slowly and repeatedly raise and lower the arms outstretched to each side.

18. Storm signals are for your information and safety. Learn them and be guided accordingly.

19. Falls are the greatest cause of injury both afloat and ashore. Eliminate tripping hazards where possible, make conspicuous those which must remain, have adequate grabrails, and require proper footwear to be used on board.

20. Always have up-to-date chart (or charts) of your area on board.

21. Always instruct at least one person on board of the rudiments of boat handling in case you are disabled — or fall overboard.

22. Keep electrical equipment and wiring in good condition. No knife switches or other arcing devices should be in fuel compartments. Allow ample ventilation around batteries.

23. Before departing on a boat trip, you should advise a responsible friend or relative about where you intend to cruise. Be sure that the person has a good description of your boat. Keep him advised of any changes in your cruise plans. By doing these things, your friend or relative will be able to tell the Coast Guard where to search for you and what type of boat to look for if you fail to return. Be sure to advise the same person when you arrive so as to prevent any false alarms about your safety.

24. Do not test fire extinguishers by squirting small amounts of the agent. The extinguisher might not work when needed. Always follow approved instructions in checking fire extinguishers.

25. A special flag hoist (red flat with white diagonal) flown from boat or buoy means skin diving operations. Approach area with caution and stay clear at least 25 yards.

26. If electrical storms are common in your area, consult your dealer for recommendation on proper procedure for grounding your sailboat. In any electrical storm, stand clear of rigging and metal pieces on the boat.

**PERSONAL FLOTATION DEVICES: REQUIREMENTS** — One Coast Guard approved personal flotation device (PFD) of suitable size for each person aboard recreational boats, including sailboats, rowboats, kayaks, and canoes. New PFD's bearing Coast Guard approval are now identified by "Types I, II, III, or IV."

**MANDATORY EQUIPMENT** — 1. Boats sixteen (16) feet or over in length: one Type I, II, or III (wearable) for each person on board and one Type IV (throwable) in each boat.

**TYPE I** — A Type I PFD is an approved device designed to turn an unconscious person in the water from a face downward position to a vertical or slightly backward position, and to have more than 20 pounds of buoyancy. Recommended for off-shore cruising. Acceptable for all size boats.

**TYPE II** — A Type II PFD is an approved device designed to turn an unconscious person in the water from a face downward position to a vertical or slightly backward position and to have at least 15.5 pounds of buoyancy. Recommended for closer, in-shore cruising. Acceptable for all size boats.

**TYPE III** — A Type III PFD is an approved device designed to keep a conscious person in a vertical or slightly backward position and to have at least 15.5 pounds of buoyancy. While having the same buoyancy as Type II, the Type III has a lesser turning ability to allow for a comfortable design for water activities such as water skiing. Recommended for in-water sports, or on lakes, impoundments, and close in-shore operation. Acceptable for all size boats.

**TYPE IV** — A Type IV PFD is an approved device designed to be thrown to a person in the water and not worn. It is designed to have at least 16.5 pounds of buoyancy. Acceptable for boats less than 16 feet and canoes and kayaks and as a throwable device for boats 16 feet and over in length.

INFORMATION REPRINTED FROM  
U.S. DEPARTMENT OF TRANSPORTATION  
UNITED STATES COAST GUARD

DEALER COPY  
BUCCANEER WARRANTY CARD

CUSTOMER COPY

SOLD TO \_\_\_\_\_ NAME \_\_\_\_\_  
ADDRESS \_\_\_\_\_ ADDRESS \_\_\_\_\_  
CITY \_\_\_\_\_ STATE \_\_\_\_\_ ZIP \_\_\_\_\_ CITY \_\_\_\_\_ STATE \_\_\_\_\_ ZIP \_\_\_\_\_  
MODEL \_\_\_\_\_ YEAR \_\_\_\_\_ MODEL \_\_\_\_\_ YEAR \_\_\_\_\_  
ENGINE SERIAL # \_\_\_\_\_ SER. # \_\_\_\_\_  
ENGINE SERIAL # \_\_\_\_\_ ENGINE SERIAL # \_\_\_\_\_  
DATE OF SALE \_\_\_\_\_ DATE OF SALE \_\_\_\_\_  
OPTIONAL EQUIPMENT PURCHASED: \_\_\_\_\_ DEALER \_\_\_\_\_  
ADDRESS \_\_\_\_\_  
PH. NO. \_\_\_\_\_

(Federal Law Requires Warranty Card Be Returned To Factory)

BUCCANEER WARRANTY REGISTRATION

SOLD TO \_\_\_\_\_  
ADDRESS \_\_\_\_\_ PHONE \_\_\_\_\_  
CITY \_\_\_\_\_ STATE \_\_\_\_\_ ZIP \_\_\_\_\_  
MODEL \_\_\_\_\_ YEAR \_\_\_\_\_ SERIAL # \_\_\_\_\_  
ENGINE SERIAL # \_\_\_\_\_ COLOR \_\_\_\_\_  
FACTORY INSTALLED OPTIONAL EQUIPMENT: \_\_\_\_\_  
FRANCHISED DEALER \_\_\_\_\_  
ADDRESS \_\_\_\_\_  
DATE OF PURCHASE \_\_\_\_\_

FOLD HERE

PLEASE CHECK THE BELOW TO ASSIST BUCCANEER IN BUILDING A MORE DESIRABLE BOAT.

WHY DID YOU PICK BUCCANEER?  QUALITY CONSTRUCTION  CABIN ACCOMODATIONS  
 PRICE  COLOR  
DID YOU BUY FROM YOUR DEALER BECAUSE OF:  PRICE  LOCAL ADVERTISING  
 DEALER REPUTATION  NATIONAL ADVERTISING  PRIOR BUCCANEER OWNER  
RECOMMENDATION  
DID YOU TRADE IN A BOAT?  YES  NO  
IF YES, WHAT SIZE? TYPE

YOUR AGE  20-25  25-35  35-45  45-55  55 or OVER OCCUPATION \_\_\_\_\_

Pride In Excellence

**BUCCANEER YACHTS**

*Division of Bayliner Marine Corporation*

P. O. BOX 24467

SEATTLE, WA. 98134





# BUCCANEER

## LIMITED WARRANTY FOR BUCCANEER SAILING YACHTS

BAYLINER MARINE CORPORATION P.O. BOX 24467 SEATTLE, WASHINGTON 98134

Bayliner Marine Corporation warrants each new boat to be free from defects in material and workmanship under normal use and service for a period of one year (12 months) from date of delivery to the original purchaser. The obligation of Bayliner under this warranty is limited to replacement or repair of a defective part free of charge by an authorized Bayliner dealer or at a Bayliner factory; this is Bayliner's option. Return transportation of any boat to the dealer or to the Bayliner factory is to be paid by the claimant. All repairs are subject to the authorization of factory trained personnel whose decisions will be final.

This warranty does not apply to (1) engines, outdrives, controls, props, batteries or other equipment or accessories carrying their own individual warranties (appropriate adjustments to them being provided by their respective manufacturers); (2) installation of engines or accessories installed by others; (3) windshield breakage or leakage; gel coat finish, cracks or crazing; (4) all canvas, vinyl, upholstery, plastics, fabric, and trim; (5) any Bayliner boat which has been altered, subjected to misuse, negligence or accident; (6) any Bayliner boat which has been overpowered according to our maximum recommended engine horsepower specifications on the capacity plate provided for each Bayliner boat model; (7) any Bayliner used for commercial purposes.

The implied warranties of merchantability or fitness for a particular purpose, if any, shall not extend beyond the period of one year (12 months) from date of delivery to the original purchaser.

PERSONAL FLOTATION DEVICES SHOULD BE CARRIED FOR EACH PASSENGER IN ACCORDANCE WITH U. S. COAST GUARD REQUIREMENTS.

Consumer's claim under this warranty must be made to the dealer from whom the boat was purchased. In the event the consumer is not satisfied with dealer's performance, he should contact Bayliner Marine Corporation. If all else fails, the consumer has the privilege of action at law to claim damages for breach of warranty.

Bayliner Marine Corporation and its dealers will perform the obligations under this warranty promptly upon notice of claim and decision that the warranty claim is valid. Obligations of the warranty will be completed within sixty (60) days after notice of a defect within the warranty.

This is a limited warranty.

Bayliner Marine Corporation shall not be liable for special or consequential damages to person or property. Any implied warranty is limited in duration to the duration of this one year warranty.

Federal law requires that warranty card be returned to factory. Warranty card enclosed.

**Pride In Excellence**

PRINTED IN U.S.A.  
BY MAGNA COLOR PRESS