

**3488**  
**COMMAND BRIDGE**  
**MOTORYACHT**  
**OWNER'S MANUAL SUPPLEMENT**



**BAYLINER**



**Port Engine Serial Number:** \_\_\_\_\_

**Stbd. Engine Serial Number:** \_\_\_\_\_

**Hull Identification Number:** \_\_\_\_\_

***Hull Identification Number***

The Hull Identification Number (HIN) is located on the starboard side of the transom. Be sure to record the HIN (and the engine serial numbers) in the space provided above. Please refer to the HIN for any correspondence or orders.

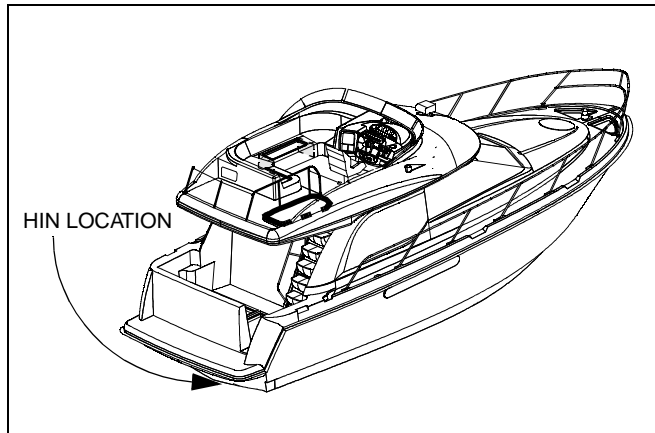

**© 2001-2002 Bayliner Technical Publications. All rights reserved.**

No part of this publication may be reproduced, stored in any retrieval system, or transmitted in any form by any means, electronic, mechanical, photocopying, recording or otherwise, without prior written permission of Bayliner.

Printed in the United States of America.

**General Notes**

The material in this document is for information only and is subject to change without notice. While reasonable efforts have been made in the preparation of this document to assure its accuracy, Bayliner assumes no liability resulting from errors or omissions in this document, or from the use of information contained herein.

Due to our commitment to product improvement, Bayliner reserves the right to make changes in the product design, specifications, and equipment at any time without notice or obligation. Illustrations and/or photos may show optional equipment.

All Bayliner products meet or exceed USCG (United States Coast Guard) and/or NMMA (National Marine Manufacturer's Association) construction standards. Manufactured with 1,1,1 Trichloroethane, a substance which harms public health and environment during the manufacturing process by destroying ozone in the upper atmosphere.

**Proprietary Rights**

This document discloses subject matter in which Bayliner has proprietary rights. The information and design disclosed herein were originated by and are the property of Bayliner. Neither receipt nor possession thereof confers or transfers any right to reproduce, copy, alter or disclose the document or any part thereof, any information contained therein, or to construct boats or any item from it, except by written permission from or written agreement with Bayliner. This document is to be returned upon request to Bayliner.

# CONTENTS

---

## CHAPTER 1: ABOUT THIS MANUAL

- 1 Dealer Service
- 1 Boating Experience
- 1 Engines/Accessories Guidelines
- 1 Qualified Maintenance
- 2 Structural Limitations
- 2 Special Care For Moored Boats
  - 2 *Sacrificial Anodes (Zincs)*
- 3 Carbon Monoxide (CO)
  - 3 *Sources of CO*
  - 4 *Carbon Monoxide Alarm System*
  - 4 *What To Do If Carbon Monoxide Is Detected*
- 4 Safety Standards
- 5 Hazard Warning Symbols

## CHAPTER 2: FEATURES / SYSTEMS

- 6 Layout View
- 7 Lifting Sling
- 8 Hull Exterior Hardware
- 9 Deck Equipment
  - 9 *Deck Fill & Pump-out Locations*
  - 9 *Windshield Wipers*
  - 9 *Anchor Windlass*
- 10 Instruments
  - 10 *Helm Layout*
- 11 Navigation & Communication Equipment
  - 11 *Depth Finder*
  - 11 *Compass*
  - 11 *Autopilot (Option)*
  - 11 *VHF Radio*
- 12 Lights
  - 12 *Navigation & Interior Lights*
  - 12 *Spotlight*
- 12 Dockside Television & Telephone Inlet
- 12 Audio & Visual Equipment
- 13 Appliances
  - 13 *Propane System (Option)*
- 14 Engines
  - 14 *Engine Cooling System*
- 14 Exhaust System
- 15 Engine Room Ventilation System

- 15 Shaft-Transmission Alignment
  - 15 *Shaft Log Packless Sealing System*
- 16 Fuel System
  - 16 *Fuel Fills & Vents*
  - 17 *Fuel Transfer Pump (Option)*
  - 17 *Fuel Filters & Separators*
  - 17 *Fuel Quality*
- 17 Oil Change System (Option)
- 17 Fire Extinguishing System (Option)
- 18 Controls
  - 18 *Steering & Shift/Throttle System*
  - 18 *Trim Tabs*
  - 19 *ICE-Integrated Control System (Option)*
- 20 Bilge Pump Systems
  - 20 *Autofloat Switches*
  - 21 *Bilge Pump Locations*
- 22 Freshwater System
  - 23 *Water Heater*
  - 24 *Hot & Cold Water Routing*
  - 25 *Gray Water Drain System*
- 26 Seawater Systems
  - 26 *Seawater Strainers*
  - 26 *Seawater Washdown (Option)*
- 27 Air Conditioner & Heater (Option)
  - 27 *Air Conditioning Pickup Routing:*
  - 28 *Air Conditioning Control Panel Locations:*
- 28 Electric Heaters (Option)
- 28 Heat Exchanger Cabin Heater (Option)
- 29 Marine Head System with Holding Tank
  - 29 *Waste System Routing (Electric Option)*
  - 30 *Waste System Routing (Vacuflush Option)*
- 30 Vacuum System (Option)
- 31 Electrical System
- 32 12-Volt DC System
  - 32 *Fuses and Circuit Breakers*
  - 32 *Battery Switches*
  - 32 *Batteries*
  - 33 *Engine Alternators*
  - 33 *Battery Charger*
- 33 AC Electrical System
  - 34 *Shore Power*
  - 34 *Connecting To Shore Power*
  - 35 *Inverter Power (Option)*
  - 36 *Generator Power (Option)*

---

## **APPENDIX A: ELECTRICAL ROUTINGS**

- 38 Deck Harness Port
- 38 Deck Harness Starboard
- 39 Windlass Harness
- 39 Bonding Harness Routing
- 40 Forward Bilge Harness Routing
- 40 Forward Bilge Harness Routing

## **APPENDIX B: WIRING SCHEMATICS**

- 41 Engine and Helm Control Wiring Diagram
- 42 DC-Distribution System-Command Bridge Wiring Diagram
- 43 DC-Distribution System-Pilot House Wiring Diagram
- 44 DC-Auxiliaries and Battery Wiring Diagram
- 45 120-Volt AC Wiring Diagram

## **APPENDIX C: EXPRESS LIMITED WARRANTY**



## CHAPTER 1: ABOUT THIS MANUAL

---

This *Owner's Manual Supplement* was prepared to provide specific information about your yacht. Please study this supplement and the *Owner's Manual* carefully, paying particular attention to Appendix C: LIMITED WARRANTY. Keep this supplement on your yacht in a secure, accessible place.

### Dealer Service

Make certain that you receive a full explanation of all systems from the selling dealer before taking delivery of your yacht. Your selling dealer is your key to service. If you experience any problems with your new yacht, immediately contact the selling dealer. If for any reason your selling dealer is unable to help, you can call us direct on our customer service hotline: 360-435-8957 or send us a FAX: 360-403-4235. A Bayliner replacement parts catalog is available online at: <http://www.baylinerparts.com>. Replacement parts can be purchased from any authorized Bayliner dealer.

### Boating Experience

If this is your first boat or if you are changing to a type of boat you are not familiar with, for your own comfort and safety, please ensure that you obtain handling and operating experience before assuming command of the yacht.

Take one of the boating safety classes offered by the U.S. Power Squadrons or the U.S. Coast Guard Auxiliary. For more course information, including dates and locations of upcoming classes, contact the organizations directly:

- U.S. Power Squadrons: 1-888-FOR-USPS (1-888-367-8777) or on the Internet at: <http://www.usps.org>
- U.S. Coast Guard Auxiliary: 1-800-368-5647 or on the Internet at: <http://www.cgaux.org>

Outside the United States, your selling dealer, national sailing federation or local yacht club can advise you of local sea schools or competent instructors.



### WARNING!

**CONTROL HAZARD!** A qualified operator must be in control of the yacht at all times. *Do not* operate your yacht while under the influence of alcohol or drugs.

### Engines/Accessories Guidelines

Your yacht's engines and accessories were selected to provide optimum performance and service. Installing different engines or other accessories may cause unwanted handling characteristics. Should you choose to install different engines or to add accessories that will affect the boat's running trim, have an experienced marine technician perform a safety inspection and handling test before operating your yacht again.

The engines and accessories installed on your yacht come with their own operation and maintenance manuals. Read and understand these manuals before operating the engines/accessories.

### Qualified Maintenance



### WARNING!

**To maintain the integrity and safety of your yacht, only qualified personnel should perform maintenance on, or in any way modify: The steering system, propulsion system, engine control system, fuel system, environmental control system, electrical system or navigational system.**

Failure to maintain your yacht's systems (listed in the warning above) as designed could violate the laws in your jurisdiction and could expose you and other people to the danger of bodily injury or accidental death. We recommend that you follow the instructions provided in this supplement, the *Owner's Manual*, the engine owner's manual and the accessory instruction sheets included with your boat.

## Structural Limitations

The command bridge, transom platform and bow platform are designed to be lightweight for proper boat balance. The load limit for these platforms and the command bridge is 30 pounds per square foot, evenly distributed.

## Special Care For Moored Boats

If moored in saltwater or fresh water, your boat will collect marine growth on its hull bottom. This will detract from the boat's beauty, greatly affect its performance and may damage the gelcoat. There are two methods of slowing marine growth:

- Periodically haul the boat out of the water and scrub the hull bottom with a bristle brush and a solution of soap and water.
- The hull below the waterline was painted with anti-fouling paint by the factory. Occasionally you will need to re-paint it with a good grade of anti-fouling paint.

### NOTICE

- **To help seal the hull bottom and reduce the chance of gelcoat blistering on moored boats, we recommend the application of an epoxy barrier coating, such as INTERLUX, *Interprotect 2000E/2001E*. The barrier coating should be covered with several coats of anti-fouling paint.**
- **Many states regulate the chemical content of bottom paints in order to meet environmental standards. Check with your local dealer about recommended bottom paints, and about the laws in effect in your area.**

## Sacrificial Anodes (Zincs)

Your yacht is equipped with sacrificial anodes to protect underwater metal parts from excessive deterioration. Sacrificial anodes should be checked regularly and replaced if they have deteriorated more than 70%. There are many factors that determine the rate at which sacrificial anodes deteriorate, including:

- Water temperature
- Salinity
- Water pollution

Stray current from the boat or dock may cause complete deterioration in just a few weeks. If there is rapid anode deterioration, measure electrolytic corrosion around your yacht with a corrosion test meter. If sacrificial anodes are not bonded correctly, they will not provide protection.

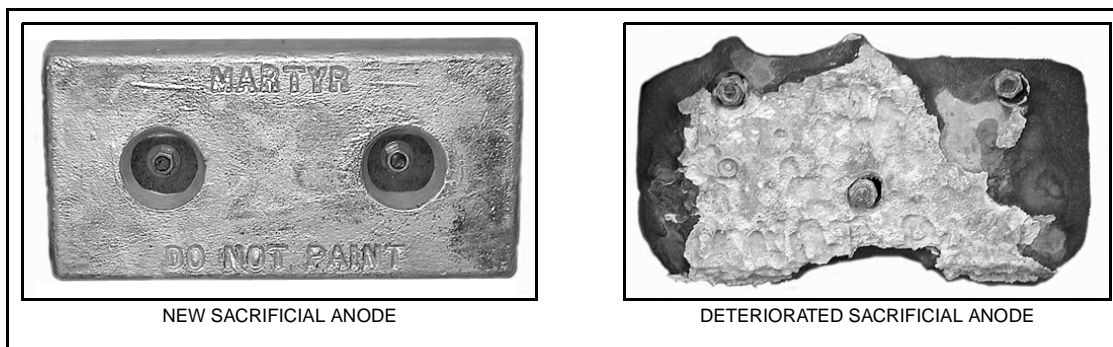

### NOTICE

**Do not paint between the zinc and the metal surface it contacts and do not paint over the zincs.**



## Carbon Monoxide (CO)

⚠ **DANGER!**



***CARBON MONOXIDE POISONING HAZARD!*** Carbon monoxide gas (CO) is colorless, odorless, and extremely dangerous. All engines, generators, and fuel burning appliances produce CO as exhaust. Direct and prolonged exposure to CO will cause **BRAIN DAMAGE** or **DEATH**. Signs of CO poisoning include headache, nausea, dizziness, and drowsiness.

CO poisoning causes a significant number of boating deaths each year. Called the "silent killer", CO is an extremely toxic, colorless, odorless and tasteless gas. Breathing CO blocks the ability of your blood to carry oxygen. The effects are cumulative, even low levels of exposure can result in injury or death. Factors increasing the effects of CO include: age, smokers or people exposed to high concentrations of cigarette smoke, consumption of alcohol, lung disorders, heart problems, and pregnancy.

### Sources of CO

Sources of CO include:

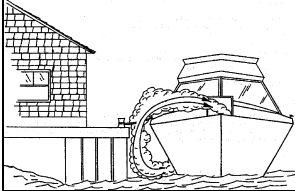

a. Using the engine or the generator when the boat is moored in a confined space.

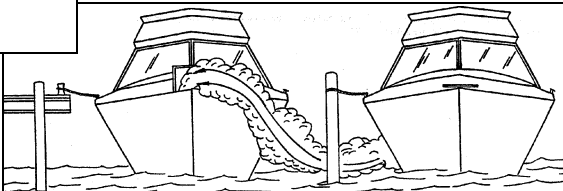

b. Mooring close to another boat that is using its engine, generator or any other CO source.

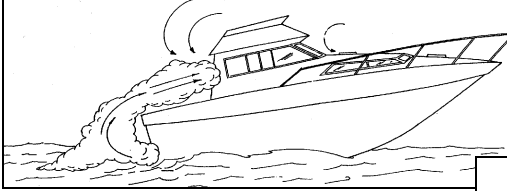

c. Running the boat with the trim angle of the bow too high.

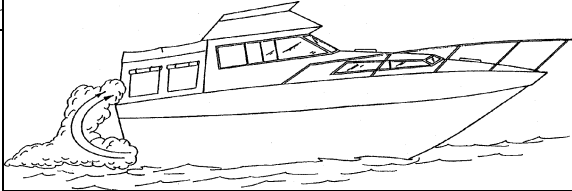

d. Running the boat without through ventilation (station wagon effect).

#### To correct stationary situations a and/or b:

- Close all windows, portlights and hatches.
- If possible, move your boat away from the source of the CO.

#### To correct running situations c and/or d:

- Trim the bow down.
- Open windows and canvas.
- When possible, run the boat so that the prevailing winds will help dissipate the exhaust.

**IMMEDIATELY** take corrective action if CO is detected (see, *Carbon Monoxide Alarm System*, on the next page).

### Carbon Monoxide Alarm System

Your boat may feature a carbon monoxide (CO) alarm system. **DO NOT DISCONNECT THE ALARM SYSTEM.** Read and understand the manufacturer's instructions for your CO alarm system. If you did not receive an instruction manual, call (800) 383-0269 and one will be mailed to you. If your yacht is not equipped with a carbon monoxide alarm, consider purchasing one from your dealer or marine supply store.

#### What To Do If Carbon Monoxide Is Detected

- Immediately ventilate and evacuate any enclosed spaces that are occupied by people and reset your CO alarm.
- Immediately move anyone showing any symptoms of CO poisoning into fresh air. See a doctor if any symptoms persist. If the person is unconscious, immediately administer oxygen or CPR and call for emergency help.

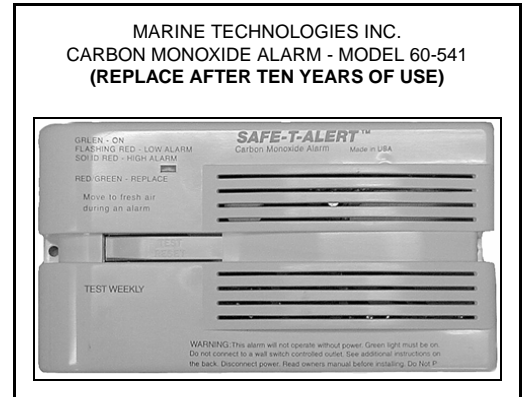

### Safety Standards

Your yacht's mechanical and electrical systems were designed to meet safety standards in effect at the time it was built. Some of these standards were mandated by law; all of them were designed to insure your safety, and the safety of other people, vessels and property.

Read the *Owner's Manual* and all accessory manuals for important safety standards and hazard information.

**⚠ DANGER!**

**PERSONAL SAFETY HAZARD!** Do not allow anyone to ride on parts of the yacht not designated for such use. Sitting on seat backs, lounging on the forward deck, bow riding, gunwale riding or occupying the transom platform while underway is especially hazardous and will cause personal injury or death.

**⚠ DANGER!**

**PERSONAL SAFETY HAZARD!** Always secure the anchor and other loose objects before getting underway. The anchor and other items that are not properly secured can come loose when the boat is moving and cause personal injury or death.

## Hazard Warning Symbols

The hazard warning symbols shown below are used throughout this Supplement to call attention to potentially dangerous situations which could lead to either personal injury or product damage. We urge you to read these warnings and the ISO symbols listed in Appendix B carefully. Follow all safety recommendations.

	<b>DANGER!</b>
<p>This symbol alerts you to immediate hazards which <u>WILL</u> cause severe personal injury or death if the warning is ignored.</p>	

	<b>WARNING!</b>
<p>This symbol alerts you to hazards or unsafe practices which <u>COULD</u> result in severe personal injury or death if the warning is ignored.</p>	

	<b>CAUTION!</b>
<p>This symbol alerts you to hazards or unsafe practices which <u>COULD</u> result in minor personal injury or cause product or property damage if the warning is ignored.</p>	

<b>NOTICE</b>	
<p>This symbol calls attention to installation, operation or maintenance information, which is important to proper operation but is not hazard-related.</p>	

						
<b>EXPLOSION HAZARD!</b>	<b>OPEN FLAME HAZARD!</b>	<b>HOT HAZARD!</b>	<b>ELECTRICAL HAZARD!</b>	<b>CO POISONING HAZARD!</b>	<b>PERSONAL INJURY &amp; FALLING HAZARD!</b>	<b>ROTATING PROPELLER HAZARD!</b>

## CHAPTER 2: FEATURES / SYSTEMS

Overall Length	Bridge Clearance	Beam	Draft	Fuel Tank Capacity (gal)	Water Tank Capacity (gal)	Holding Tank Capacity (gal)
35' 0"	14' 1"	11' 8"	3' 2"	224	92	30

### Layout View

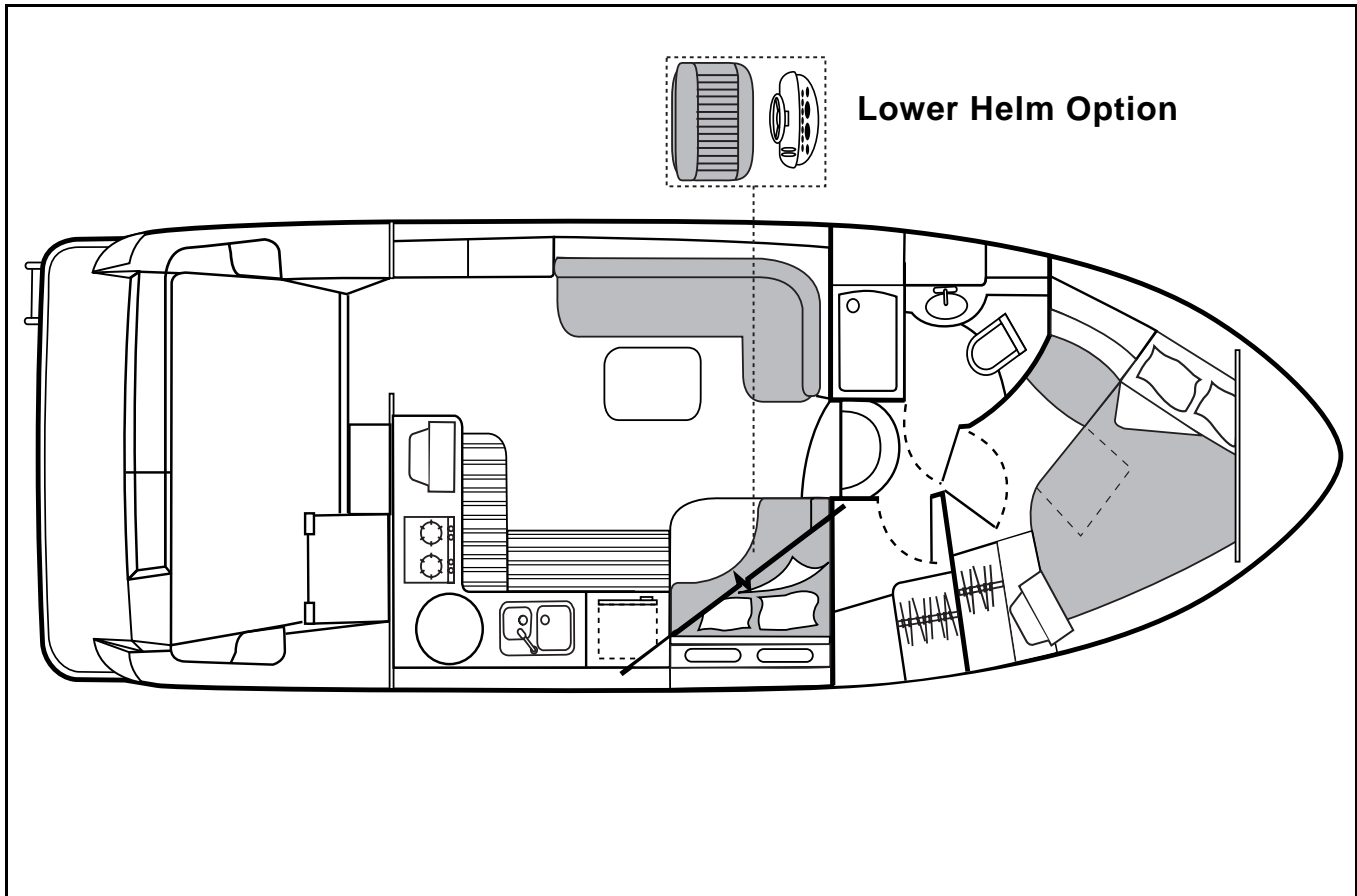

## Lifting Sling

NOTE: *Lifting sling positions shown here are typical for port and starboard sides.*

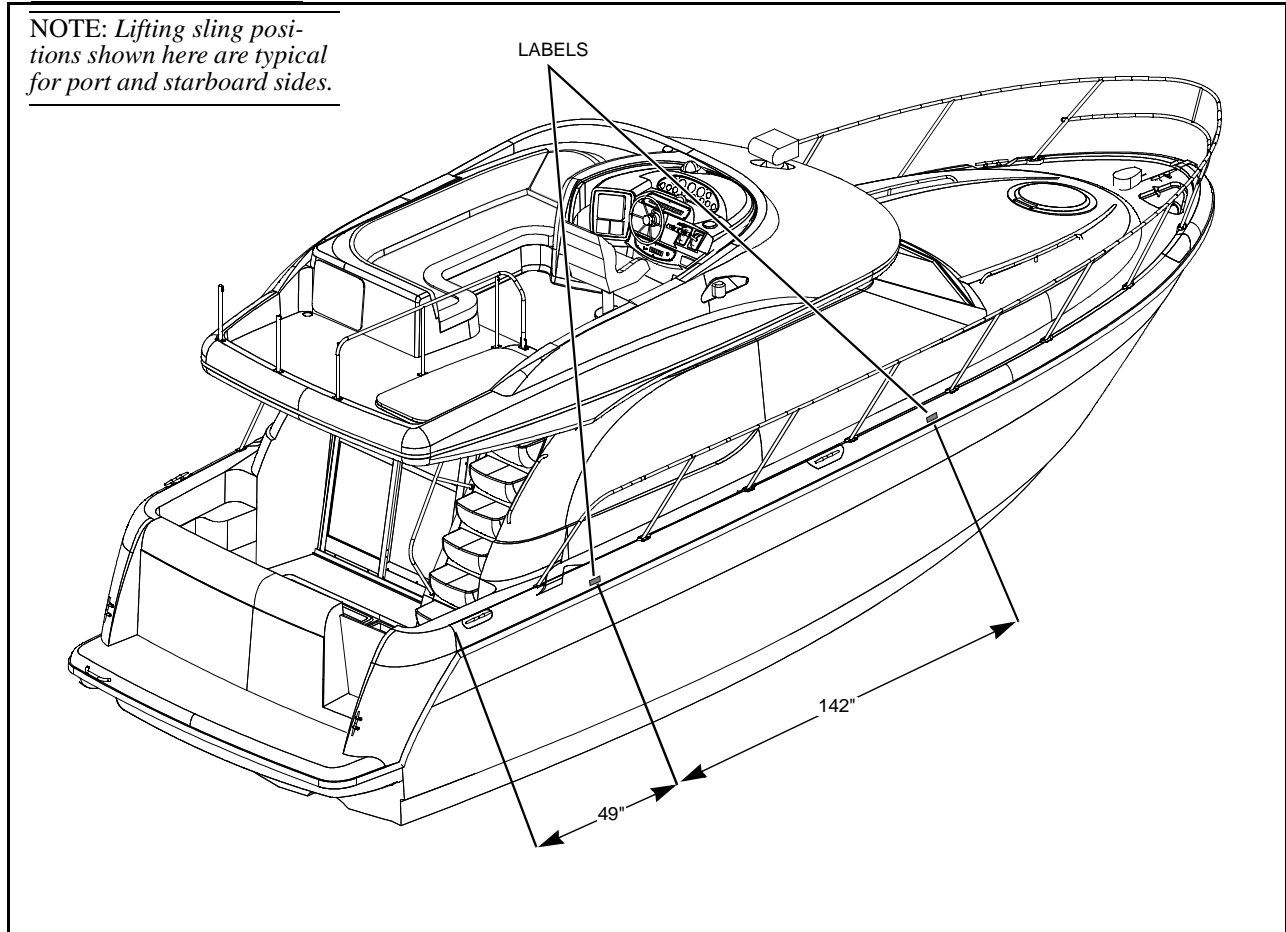

### CAUTION!

***PRODUCT OR PROPERTY DAMAGE HAZARD!***

- When lifting any boat always use a spreader bar. The spreader bar must be equal to the width of the boat at the lifting point.
- Secure the slings to one another to prevent the forward sling from sliding up along the fore-foot of the yacht.

### Hull Exterior Hardware

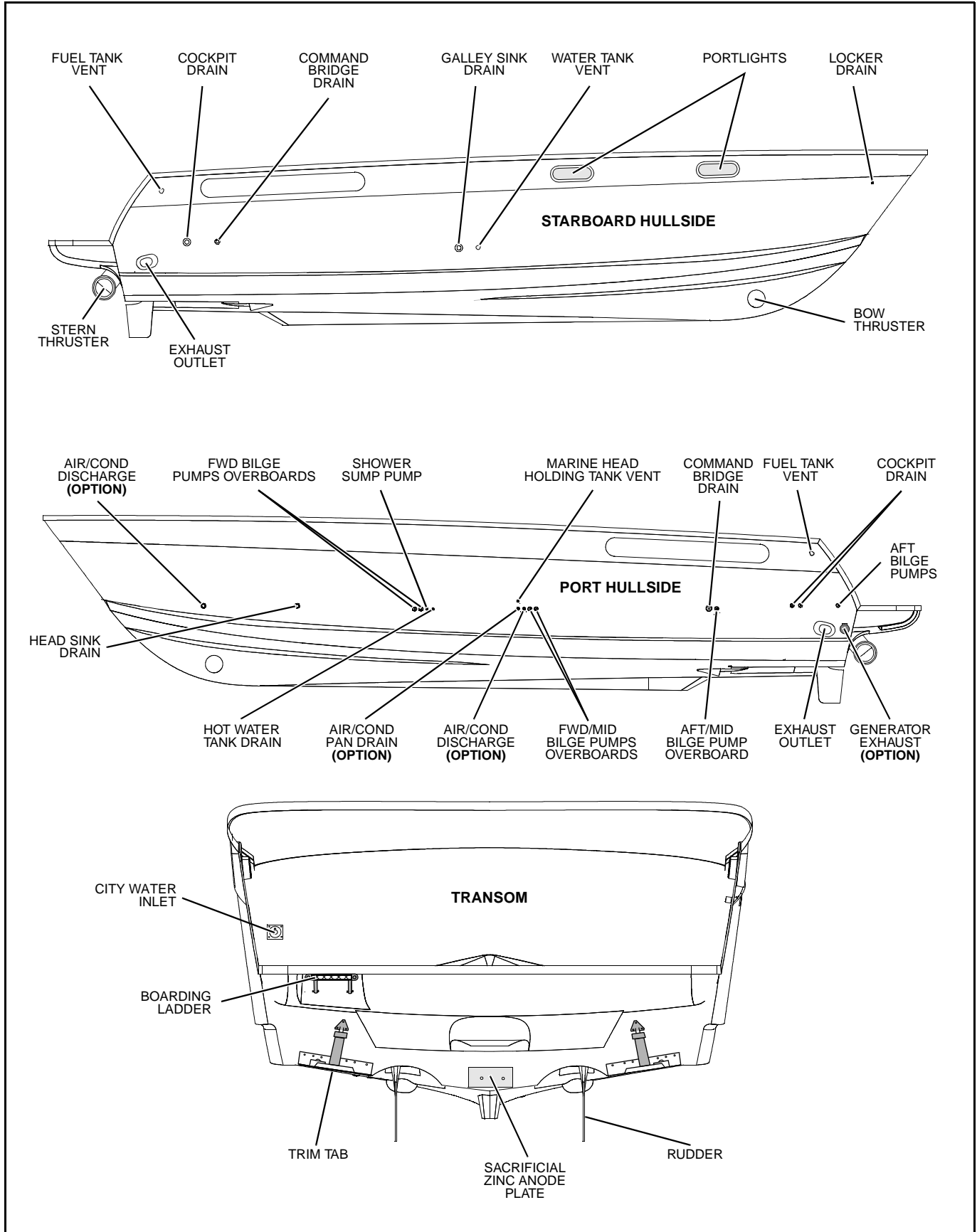

## Deck Equipment

### Deck Fill & Pump-out Locations

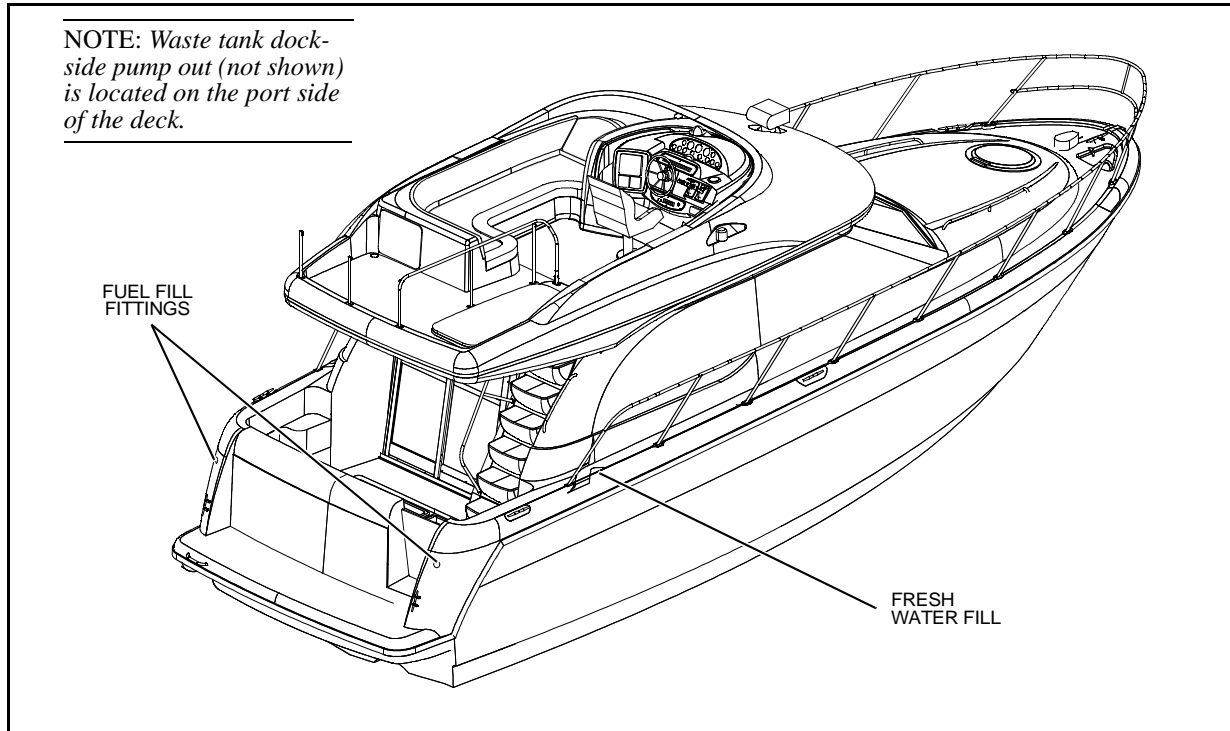

### Windshield Wipers

- Wiper blades must be replaced when they become worn or deteriorate due to weathering. Replace wiper blades using 28" blade refills. Instructions for replacing the wiper blades can usually be found on the blade replacement package.

### Anchor Windlass

Before using the anchor windlass, read the windlass manual included in your yacht's owner's packet and observe the following:

- To haul the anchor, use engine power (*not* the windlass) to move the boat to, and directly over the anchor.
- Disengage the anchor from the bottom by pulling it *straight up* with the windlass. *Do not* pull the boat to the anchor using the windlass or continue to operate the anchor windlass if it stalls or is overloaded.

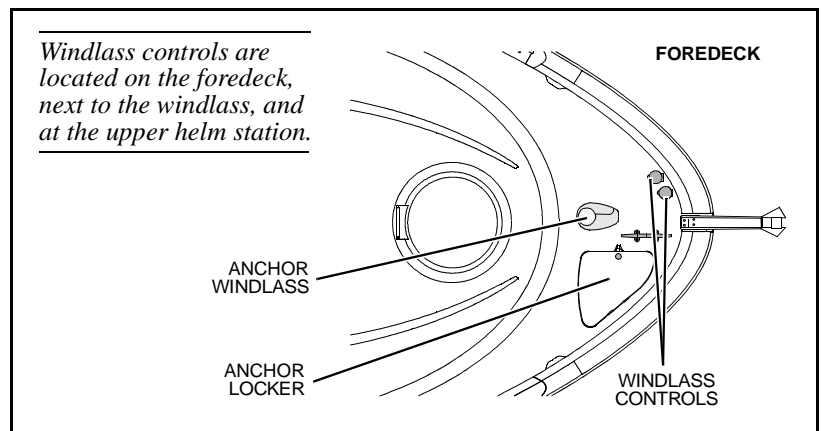

# Instruments

## Helm Layout

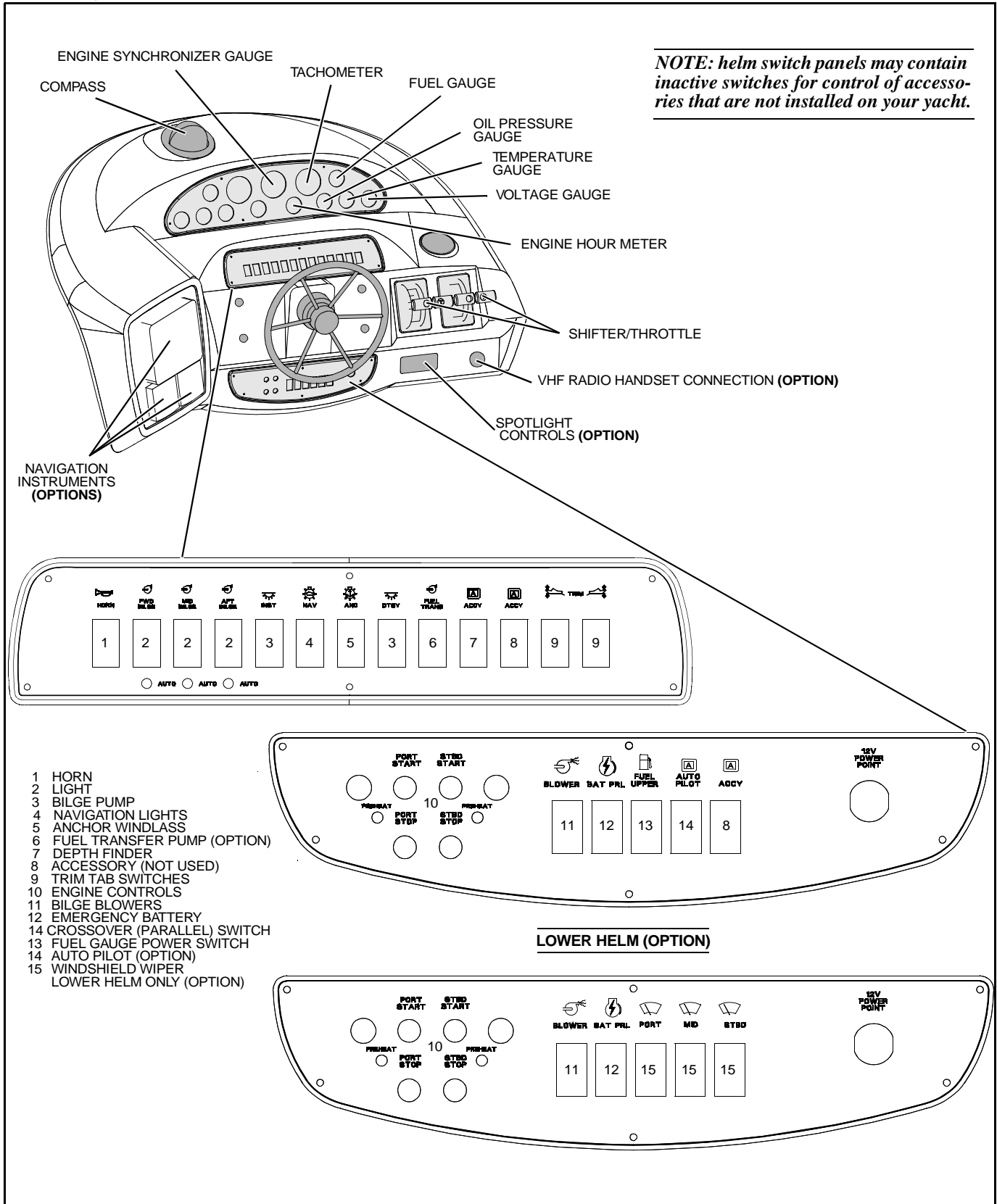



## Navigation & Communication Equipment

The owner's packet contains operation manuals for all navigation & communication equipment installed on your yacht. Thoroughly read and understand these manuals before using these systems for the first time and observe the following:

### ***Depth Finder***

Your motoryacht features a depth finder (depth sounder) at the helm station. The depth finder provides you with measurements of water depth beneath the boat.



### **WARNING!**

- ***Do not use the depth finder as a navigational aid to prevent collision, grounding, boat damage or personal injury.***
- ***When the boat is moving, submerged objects will not be seen until they are already under the boat. Bottom depths may change too quickly to allow time for the boat operator to react. If you suspect shallow water or submerged objects, operate the boat at very slow speeds.***

### ***Compass***

Your yacht is equipped with a compass at the helm station. Carefully read and follow the manufacturer's calibration and operating instructions provided in the boat's owner's packet.

### **NOTICE**

**Compass accuracy can be affected by many factors. Have a qualified technician calibrate your compass. Make sure the technician gives you a deviation card which shows the corrections to apply in navigational calculations. Keep a copy of the deviation card at each helm.**

### ***Autopilot (Option)***

Your yacht may feature an **optional** autopilot system which can be turned on at the upper helm station. The autopilot will aid you in maintaining the chosen heading of your yacht.



### **WARNING!**

***Never leave the helm while the autopilot system is on! A qualified operator must monitor the autopilot system at all times and keep lookout for other marine traffic and other hazards.***

### **NOTICE**

**The autopilot system is only an aid to navigation. It's accuracy can be affected by many factors, including equipment failure or defects, environmental conditions & improper handling or use.**

### ***VHF Radio***

Your yacht may include an VHF (Very High Frequency) radio. The VHF radio can be used to access weather reports, summon assistance or contact other vessels as permitted by the FCC (Federal Communications Commission). Contact the FCC for licensing, rules and regulations concerning VHF radio usage.

## Lights

### Navigation & Interior Lights

Read the navigation section of the *Owner's Manual* and make sure that you understand navigation light usage. The navigation and interior lights supplied with your yacht are of top quality, but you should be aware that failure may sometimes occur for a variety of reasons:

- There may be a tripped circuit breaker. (Check the push-to-reset breakers at the upper helm).
- The bulb may be burned out (Carry spare bulbs for replacement).
- The bulb base may be corroded (Clean the base and coat it with non-conductive electrical lubricant).
- A wire may be damaged or may have come loose (Repair as required).



### CAUTION!

- **Avoid the storage of gear where it would block navigation lights from view.**
- **Prolonged use of cabin interior lights (overnight) will result in a drained battery. Be conservative in the use of battery power.**

### Spotlight

Your yacht is equipped with a spotlight on the command bridge of your yacht and can be controlled from the upper helm station. Read the operating instructions included in your yacht's owner's packet.

## Dockside Television & Telephone Inlet

Your yacht is equipped with a dockside cable TV (television) and telephone inlet.

- The TV/telephone dockside inlet is located in the transom storage locker next to the shore power inlets.
- To use a telephone or receive cable TV transmission, the yacht must be hooked up to a dockside source using the TV/telephone inlet.

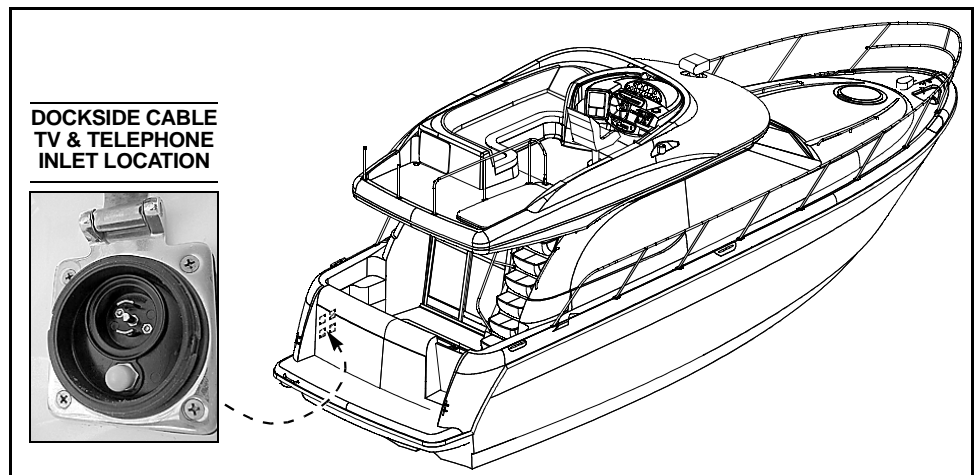

## Audio & Visual Equipment

All audio and visual equipment installed on your yacht have separate manuals explaining their operating instructions.

### NOTICE

**AM radio reception may be impaired anytime the engines are running.**

## Appliances

The owner's packet includes operating and maintenance manuals for all appliances installed in your yacht. Carefully read and understand these manuals before attempting to operate or perform maintenance on any appliance.

Appliances operate on 120v AC power, which may be supplied from shore power, **optional** generator power or **optional** inverter power. There may not be sufficient generator or inverter power to operate all AC appliances at the same time. Make sure the AC breaker is turned on for the appliance you wish to use.

**⚠ WARNING!**



**BURN HAZARD!**

- **Do not touch stove burners, grates or areas near the stove units as they may be hot even when they are dark in color. Areas near burners and grates may become hot enough to cause burns.**
- **During and after use, do not touch or let clothing or other flammable material come in contact with heated units or areas near the units (burner tops, main frame sides and back, sea rails and pot holders) until they have had sufficient time to cool.**

## Propane System

Your yacht may feature a propane system. Read the propane stove operating instructions included in your yacht's owner's packet.

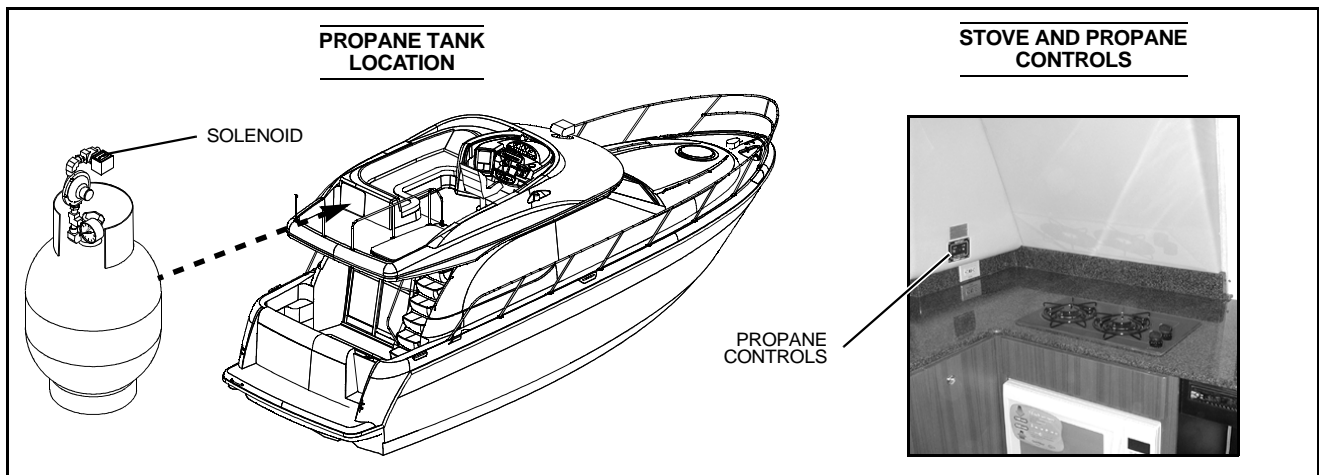

**⚠ DANGER!**



**CARBON MONOXIDE POISONING HAZARD!**

**The propane stove is a potential source of dangerous carbon monoxide gas (CO). Do not operate without adequate ventilation.**

## Engines

The owner’s packet contains detailed engine operation and maintenance manuals. Read and understand these manuals *before* using or working on the engines.

### Engine Cooling System

The engine cooling system circulates raw water around components and also uses a freshwater heat exchanger on the engine to reduce engine temperature.

- Make sure both engine seawater intake valves (seacocks) are *open* before starting the engines and keep the seacocks *open* while the engines are running.
- The cooling system’s seawater strainers should be checked for leaks and debris every time you use your yacht. For instructions on how to clean the seawater strainers, see the *Seawater System* section of this Supplement.

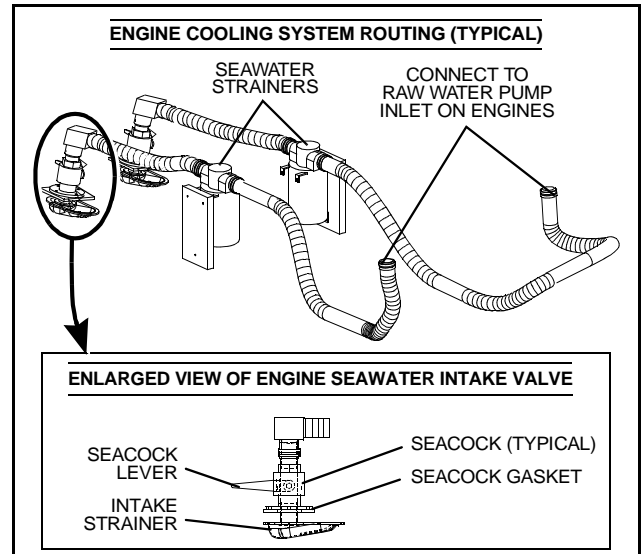

**⚠ CAUTION!**  
**SYSTEM DAMAGE HAZARD!** The engine cooling system’s seacocks must be opened before engines are started and during engine operation.

## Exhaust System

The exhaust system is designed to keep water out of the engines in most sea conditions, however, do not anchor the stern to sea or shut the engines off if high seas might flood the exhaust system. Always consider the sea conditions before anchoring or shutting off the engines.

**⚠ DANGER!**  
**CARBON MONOXIDE POISONING HAZARD!**  
 Leaking engine and/or generator exhaust is a source of dangerous carbon monoxide gas (CO). Check all exhaust systems before each trip.

- Look for leaks in exhaust systems of both generator and propulsion engine(s).
- Look for discoloration, water leaks, carbon or stains around joints.
- Make sure all exhaust clamps are in place and secured.
- Make sure ventilation systems work and are not obstructed or restricted.
- Make sure gaps around engine room plumbing, cableways, exhaust system, doors, hatches, and access panels are minimized to reduce the chance of CO entering the living space(s).

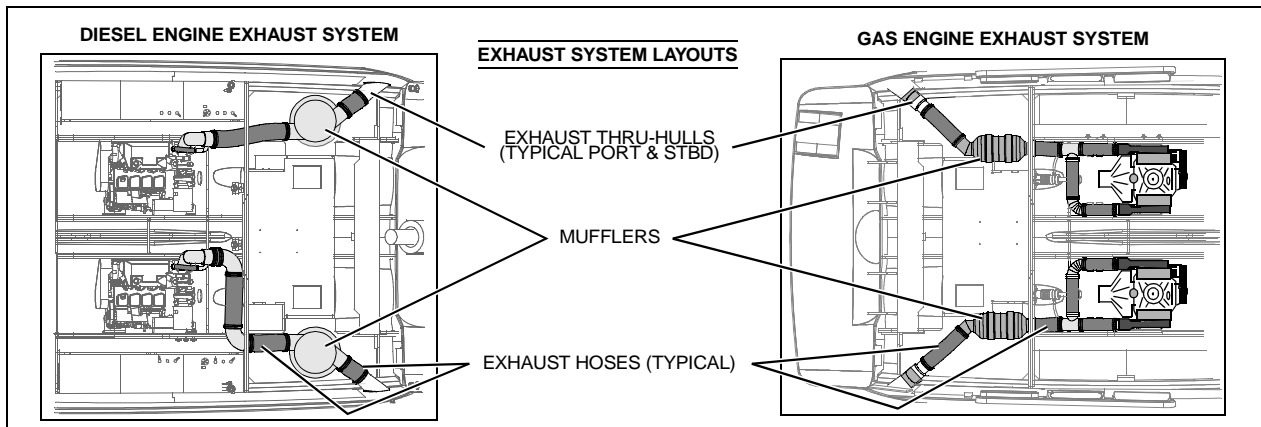

## Engine Room Ventilation System

The bilge blowers remove fumes from the engine room and draw fresh air into the compartment through the deck vents. To ensure fresh air circulation, use the bilge blowers for at least four minutes before starting the engines or **optional** generator and while operating the yacht below cruising speed.

! **WARNING!**

**Use of the blower system is not a guarantee that explosive fumes have been removed. If you smell any fuel, do not start the engines. If the engines are already running, immediately shut off the engines and all electrical accessories and check immediately. Do not obstruct or modify the ventilation system.**

## Shaft-Transmission Alignment

Alignment between the engine transmission output shaft and the propeller is very critical. The alignment has been performed at the factory and was rechecked by the dealer after the boat had been in the water for 48 hours.

- An alignment inspection should be performed by a marine mechanic as part of the routine maintenance program after the initial 30 hours of operation, then every 60 hours and whenever unusual noise or vibration is noticed.
- Shaft-transmission alignment should be performed by a marine mechanic since it requires moving the engine and prop shaft.
- To insure proper alignment after a haulout or dry storage, wait 48 hours after launching before final alignment adjustments by a marine mechanic are made.

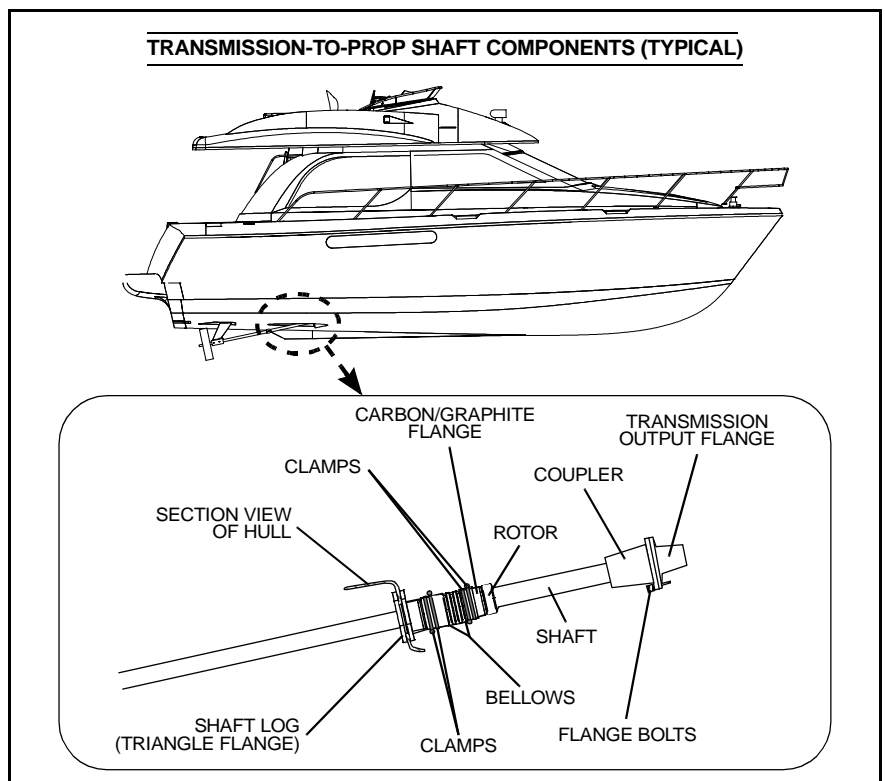

! **CAUTION!**

**SYSTEM DAMAGE HAZARD!**

- **If you suspect a shaft-transmission misalignment, have a qualified mechanic perform an alignment inspection as soon as possible.**
- **Continued use may lead to premature engine, transmission, shaft, shaft seal and/or hull damage!**

## Shaft Log Packless Sealing System

The shaft log packless sealing system's shaft seal is a maintenance-free, watertight seal that doesn't require packing or adjustments.

## Fuel System

Carefully read the fuel section of both the *Owner's Manual* and the engine operation manual, paying special attention to the subject of *fuel recommendations*. These manuals can be found in your yacht's owner's packet.

**! WARNING!**



**FIRE, EXPLOSION AND OPEN FLAME HAZARD!**

- It is very important that the fuel system be inspected thoroughly the first time it is filled and at each subsequent filling.
- The fueling instructions in the *Owner's Manual* and the fuel recommendations in the engine operation manual *must* be followed.

**! CAUTION!**

- Air in the diesel supply system can stop an engine or severely restrict performance. If you suspect air in the fuel lines, refer to your engine operation manual for detailed instructions on how to *bleed* the system.
- Avoid the storage or handling of gear near the fuel lines, fittings and tank.

**NOTICE**

Discharge of oil, oil waste or fuel into navigable waters is prohibited by law. Violators are subject to legal action by the local authorities.

### Fuel Fills & Vents

- Fuel fills are located on the port and starboard side decks. Fuel receptacle caps are marked "Diesel" or "Gas". If you have trouble filling a fuel tank, check to see that the fuel fill and vent lines are free of obstructions and kinks.
- Fuel vents are located in the hull below the same general area as the fill.

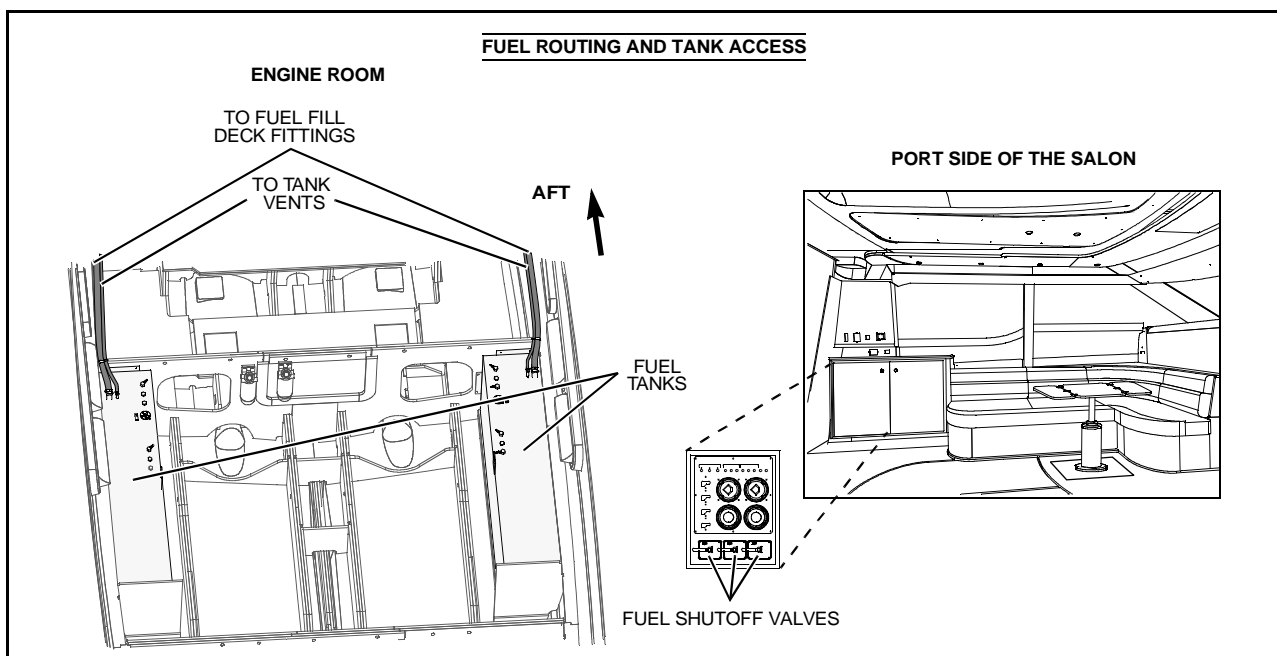

### Fuel Transfer Pump (Option)

The **optional** fuel transfer pump is used to pump fuel from one tank to another. The fuel transfer pump switch is located at the upper helm station.

**CAUTION!**

**ENVIRONMENTAL HAZARD! NEVER transfer fuel into a full (or nearly full) fuel tank. Fuel transferred into a full tank may spill overboard through the tank venting system.**

### Fuel Filters & Separators

Fuel filters and separators should be inspected periodically for debris and replaced as needed (according to the instructions detailed in your engine manual, generator manual and in the filter literature). Fuel filters are located in the engine room on the aft wall next to the power inverter.

### Fuel Quality

- The quality of the fuel is very important for good engine performance and long engine life. Fuel should be clean and free of contamination. Your fuel tanks should be kept full whenever possible. This will reduce the amount of water condensation and reduce the possibility of contamination. Allow for expansion due to warmer temperatures.
- Ask your dealer or local marina about fuel additives that help prevent fungus growth or buildup in your tanks.

### Oil Change System (Option)

Your yacht may be equipped with an oil change pump to simplify draining and filling engine and generator oil. See the operating instructions included in your owner's packet for information on the use of this system.

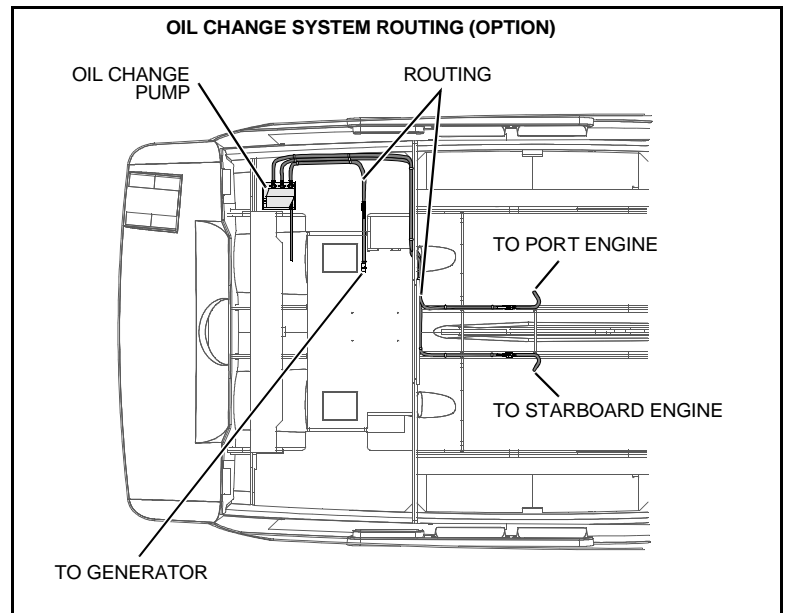

### Fire Extinguishing System (Option)

Your yacht may feature an **optional** fire extinguishing system. This system is designed to automatically activate whenever direct heat from a fire is detected in the engine room or generator compartment.

*Before* using your yacht for the first time; read and understand the fire extinguisher system's instruction and maintenance manual and observe the following:

## Controls

### Steering & Shift/Throttle System

Your yacht is equipped with a manual hydraulic steering system. This system will operate differently from a car's power steering system.

- A rhythmic pulsing when turning the wheel is a characteristic of the pump and is *not* a malfunction. Also, when coming off a hard-over position, resistances may be felt, followed by a distinct sound. This is a normal situation resulting from the release of the system's check valve.
- The fluid reservoir for the hydraulic steering system is located in the rear machinery compartment. Check the fluid levels and pressure regularly.

### Rudder Stuffing Gland

The rudder stuffing gland is part of the assembly where the rudders emerge from the bottom of the boat. The shaft stuffing gland should *not* leak any water. If a leak develops, it can usually be stopped by tightening the packing gland nuts *slightly*. Do not over tighten the packing gland nuts. If stuffing gland leakage becomes excessive, packing replacement can be performed as follows:

1. Remove the boat from the water.
2. Loosen the packing gland nuts and back the packing gland from the sleeve.
3. Remove the old packing.
4. Wrap new packing around the shaft.
5. Cut the rings with a razor blade at an angle approximately 30 degrees to the long axis of the shaft.
6. Stagger the ends of each ring around the shaft and insure that the rings are at the bottom in the sleeve.
7. Tighten the packing gland nuts until resistance is felt.

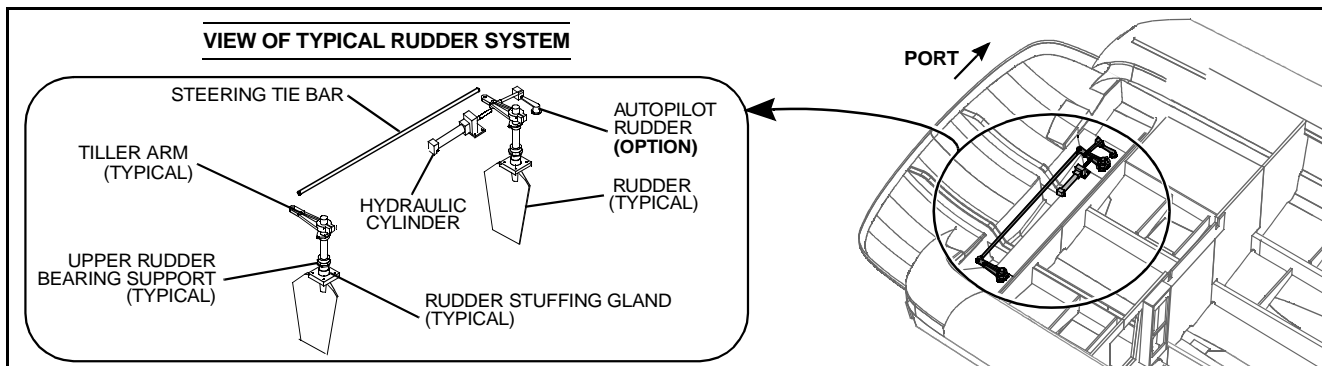

### Trim Tabs

The trim tabs may be used to help keep your boat level at cruising speeds.

The trim tabs are controlled by two rocker switches at each helm station.

Before using the trim tab rocker switches, read and understand the trim tab operation manual included in your yacht's owner's packet.

Observe the following:

- Once cruising speed is reached, the port or starboard trim switch may be used (one at a time) to level the boat. Perform trim tab adjustment with several short touches to the switch rather than one long one. After each short touch allow several seconds for the hull to react.

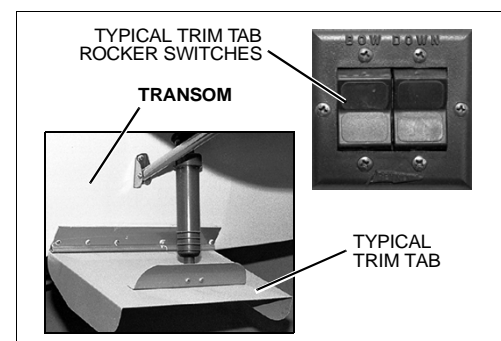



- The trim tab hydraulic fluid reservoir is located in the aft machinery compartment. The fluid level must be checked periodically (at least once a year) and refilled as necessary.

**⚠ WARNING!**

**LOSS OF CONTROL HAZARD!**

**Improper use of trim tabs will cause loss of control!**

- *Do not* allow anyone unfamiliar with trim tabs to operate them.
- *Do not* use trim tabs in a following sea as they will cause broaching or other unsafe handling characteristics.
- *Do not* use trim tabs to compensate for excessive unequal weight distribution.

**ICS-Integrated Control System (Option)**

Your yacht may be equipped with an **optional** Integrated Control System. The system includes both bow and stern thruster modules and a control module. The control module with the ON OFF buttons and the control joy stick are located at the upper helm. Read and understand the *Side Power Installation and user's manual* before using this system. Follow all user precautions carefully.

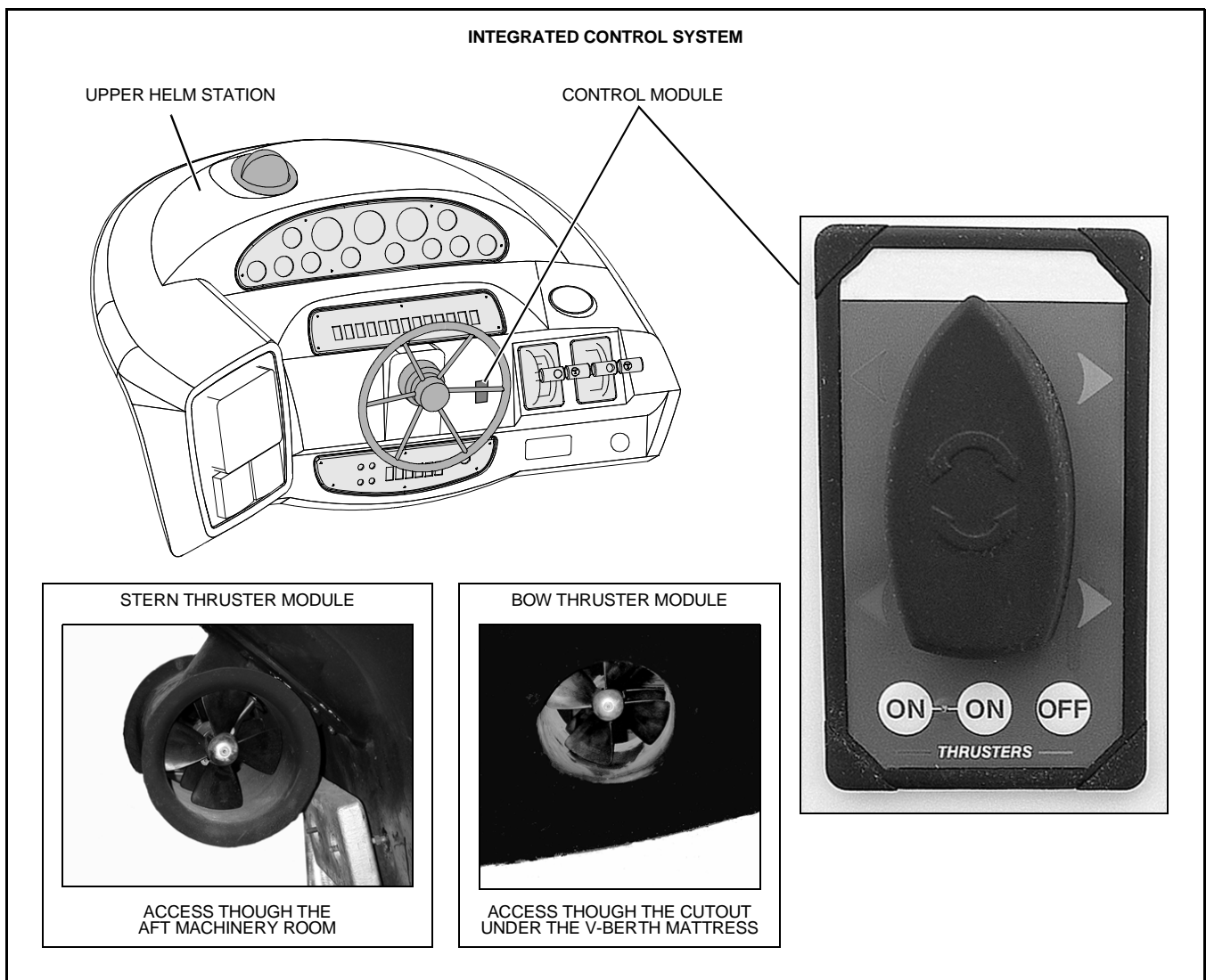

## Bilge Pump Systems

Your yacht is equipped with six impeller-type bilge pumps which are used to pump water out of the bilge. Bilge pumps are controlled by automatic bilge pump float switches (autofloat switches) and/or switches on the dash panel.

### *Bilge Pump Testing*

Bilge pumps are critical to the safety of your boat. Check the bilge pumps often to make sure that they are working properly. Test each pump individually.

#### *To test each bilge pump:*

1. Turn on the manual switches at the helm.
2. Make sure that water in the bilge is pumped overboard.

If there is water in the bilge and the pump motor is running but not pumping:

1. Inspect the discharge hose for a kink or collapsed area.
2. Check the bilge pump housing for clogging debris as follows:

#### *To check for clogging debris in pumps:*

1. With your thumb and forefinger squeeze the holding tabs on each side of the power cartridge.
2. Lift out the power cartridge.
3. Check the pump and the housing and clear any debris.

#### *Reinstall the power cartridge:*

1. Align the tabs and slots and press firmly until the tabs click into place.
2. Make sure that the power cartridge is locked into place.

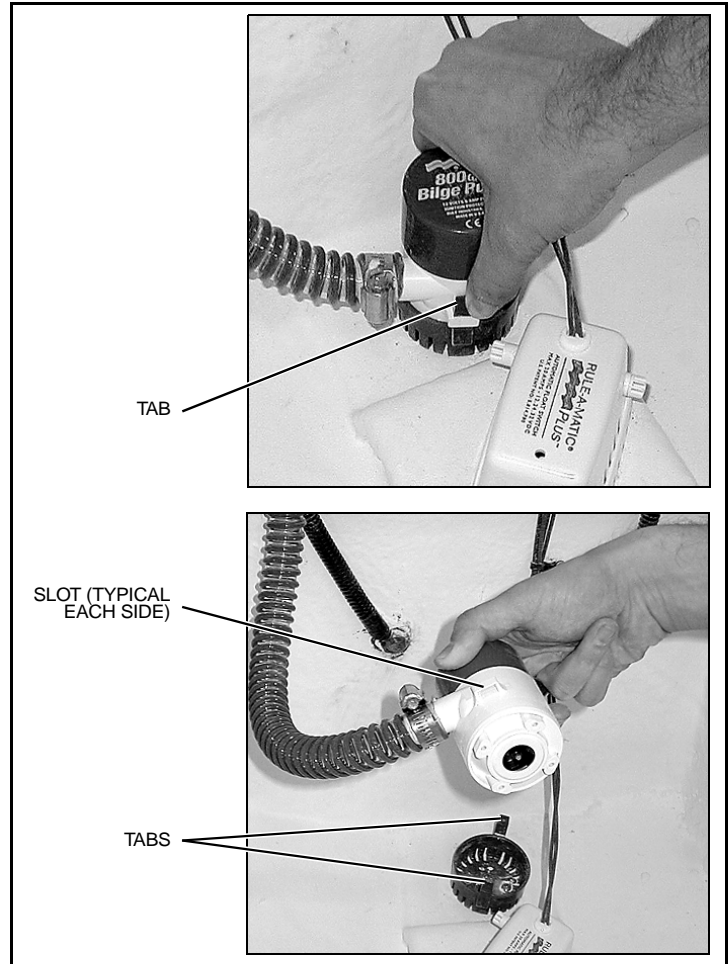

## Autofloat Switches

Automatic bilge pumps use an electromagnetic float (autofloat) switch to automatically activate the pump whenever water accumulates above a preset level in the bilge. An autofloat switch is normally mounted next to the bilge pump it activates. Autofloat switches should be tested often for proper operation as follows.

#### *To test a float switch:*

1. Lift the float up by turning either white plastic knobs 1/4 turn. As the float is lifted, the bilge pump should turn on. If lifting the float does not turn the pump on, check the circuit. Some models are equipped with in-line fuses near the battery and other have circuit breakers on the DC panel. If the fuse is good or the circuit breaker set, but the switch does not work, it may indicate a bad switch or possibly a low battery.
2. Release the knob to lower the float and return the float switch to auto mode.

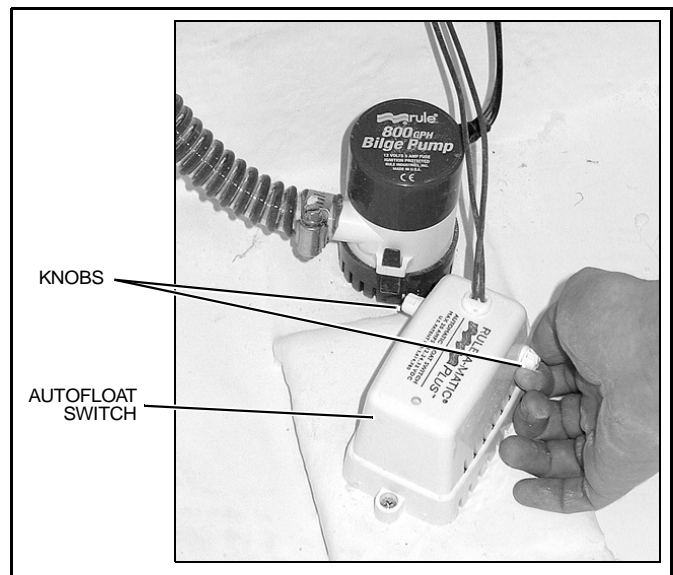

**Bilge Pump Locations**

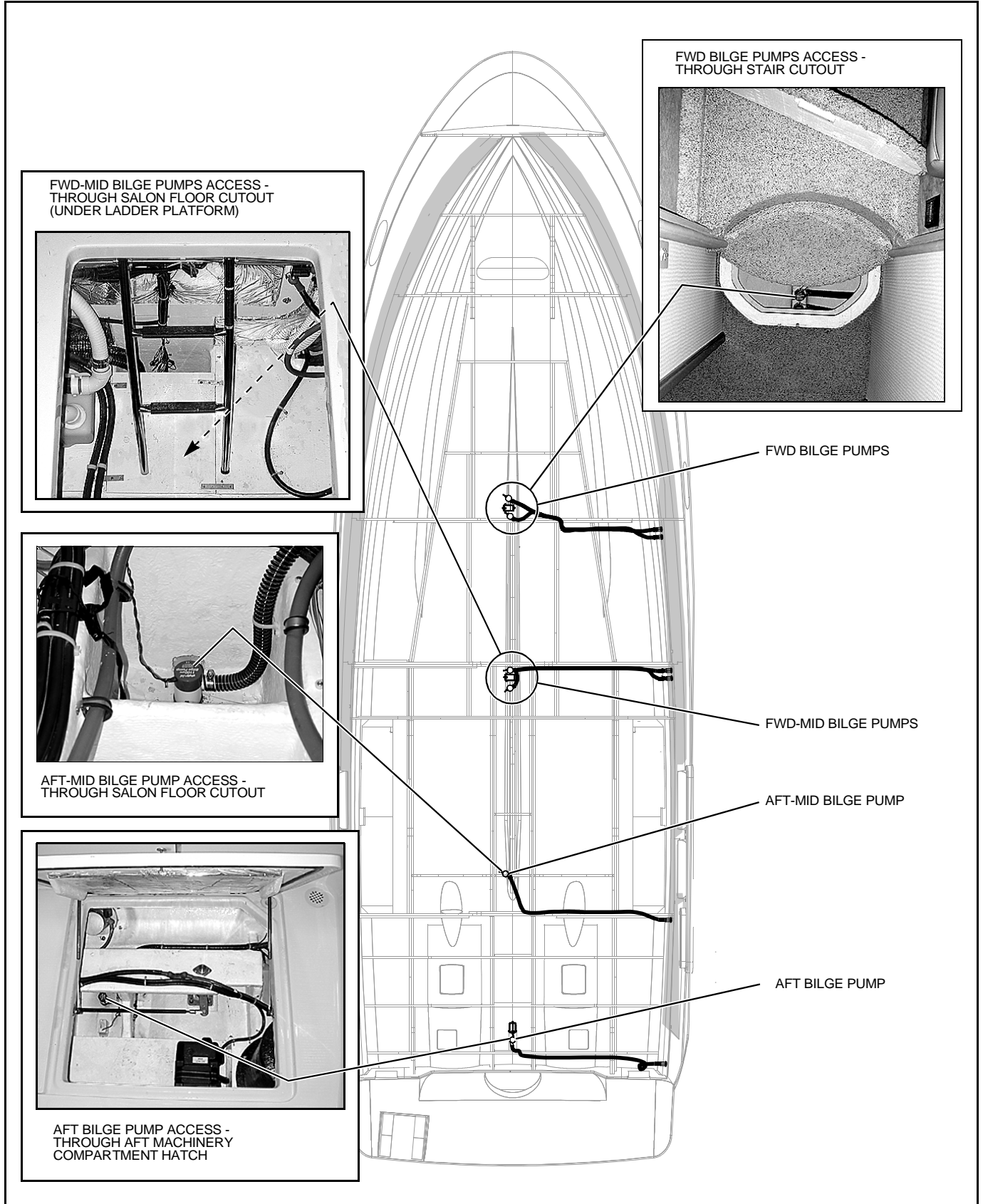

## Freshwater System

The water tank fill fitting is located on the port side deck (see *Deck Fill & Pump-out Locations*). The city water inlet is located on the port side of transom.

A pressure accumulator tank is installed in the freshwater system. The pressure accumulator tank assists the pressure pump by reducing on/off cycling and distributing an even flow of water.

### *When your boat is to be left unattended for long periods of time:*

- Pump the water tanks dry to prevent stored water from becoming stagnant and distasteful.
- Should it become necessary to disinfect the freshwater system, ask your dealer about treatments available for your yacht's system.

### *Inspect and clean the water filter often:*

- The filter is located on the water pump. The water pump is located on the port side of the water tank.
- You can access this filter either from the aft machinery compartment or the main engine room. The water tank is located between these two compartments.
- When the filter is unscrewed, water will drain out of the fresh water tank until the tank level reaches the level of the pump. To avoid excessive spillage, clean the filter when the tank is less than half full.
- The water level monitor, located on the DC panel, displays the amount of water in the fresh water tank. To check water level, on the DC panel: Make sure the *water tank monitor breaker* is turned ON then press the *water tank monitor switch*.

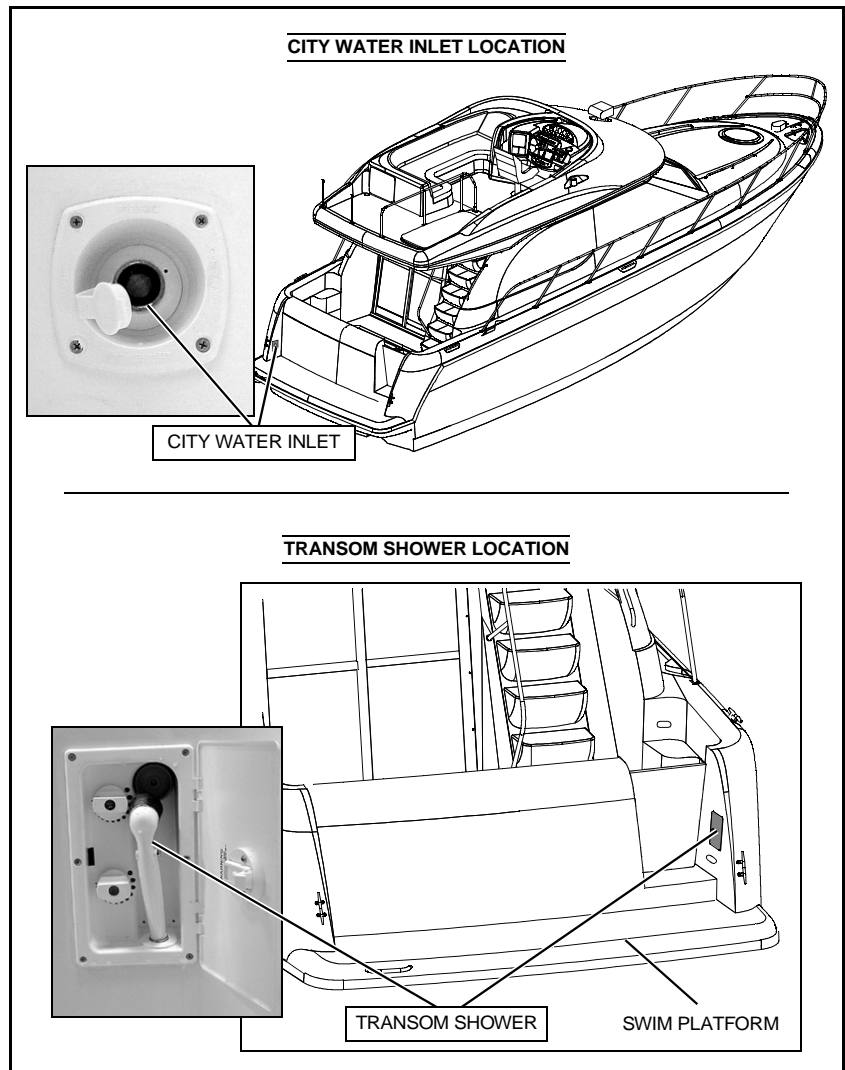

## NOTICE

**The water level monitor may not be 100% accurate, so you should fill the water tanks at every opportunity to avoid running short of freshwater.**

- To use the freshwater system when not connected to a dockside water supply, turn on the water pump's DC breaker, located on the DC panel.
- Turn OFF the water pump's DC breaker on the DC panel when any of the following occurs:
  - ✓ When the boat is not in use
  - ✓ When the water tank is empty
  - ✓ When connected to a dockside water supply

**Water Heater**

Your yacht is equipped with a 11 gallon water heater. There is a push to reset circuit breaker on the unit in addition Please read the manufacturer’s instruction manual supplied in your yacht’s owner’s packet and observe the following warnings:

**! WARNING!**

**! SCALDING HAZARD!** Water heated by the water heater can reach temperatures high enough to scald the skin.

**! CAUTION!**

- **WATER HEATER DAMAGE HAZARD!** DO NOT energize the AC water heater electrical circuit until the heater is *completely* filled with water. Even momentary operation in a dry tank will damage the heating elements. Warranty replacements *will not* be made on elements or tank damaged in this manner. The tank is full if water flows from the tap when the hot water is turned on in the galley.
- Water heaters should be drained (power turned *off*) when the possibility of freezing exists.

The water can be heated two ways:

1. By AC electrical power.
  - The water heater breaker on the AC panel must be turned *on* before the water will be heated.
2. By the engine heat exchanger (not available with some engine options).
  - Running the port engine will heat the water.

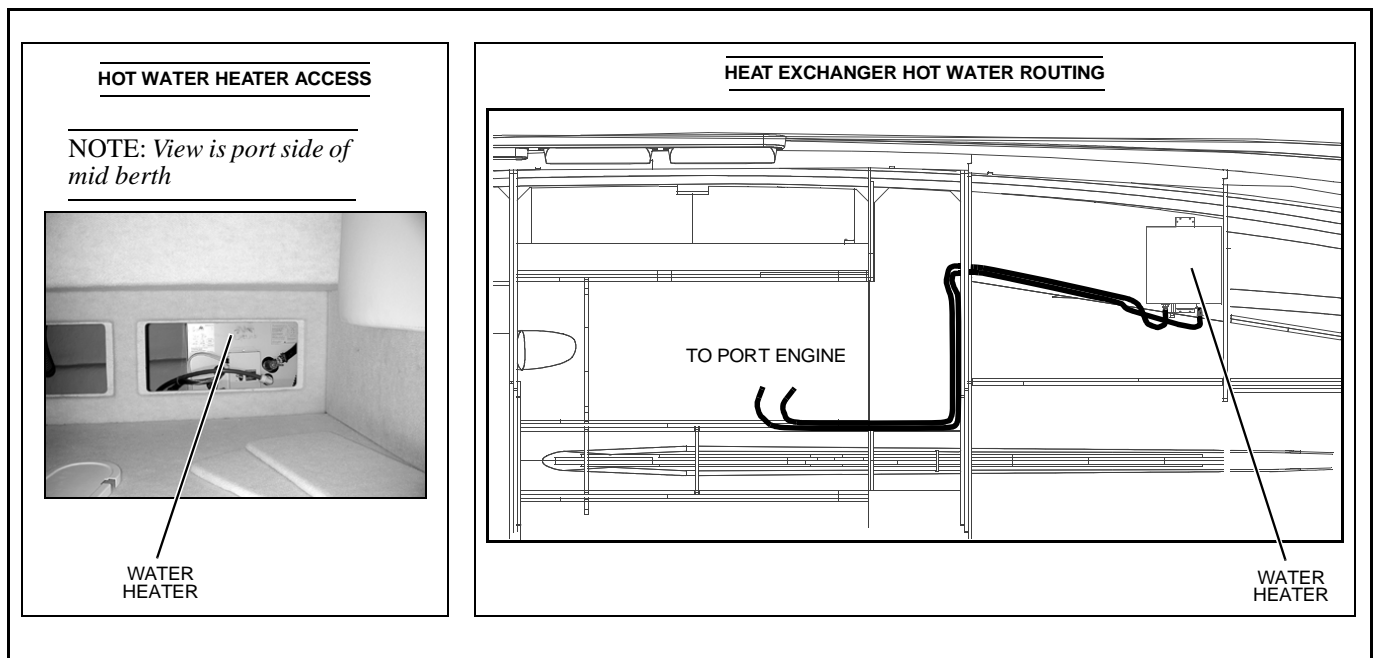

**Hot & Cold Water Routing**

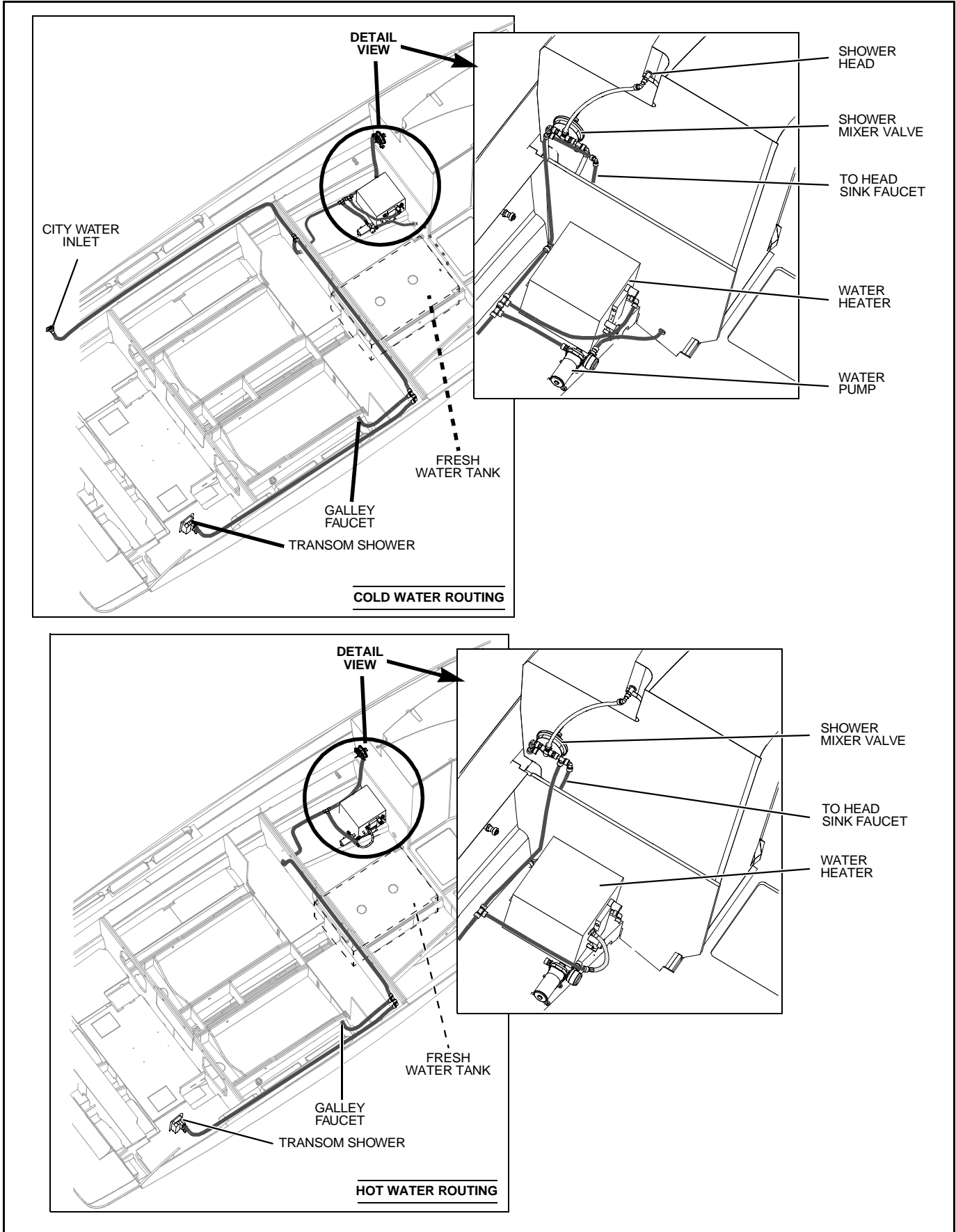

**Gray Water Drain System**

- Gray water (water from sinks and showers) above the waterline is gravity drained overboard, while gray water below the waterline is drained into a holding tank.
- When gray water in the holding tank reaches a predetermined level, the tank’s float switch automatically turns on the sump pump to pump the gray water overboard.
- The shower sump pump can be accessed through the cutout in the hallway floor at the bottom of the stairs leading to the stateroom.

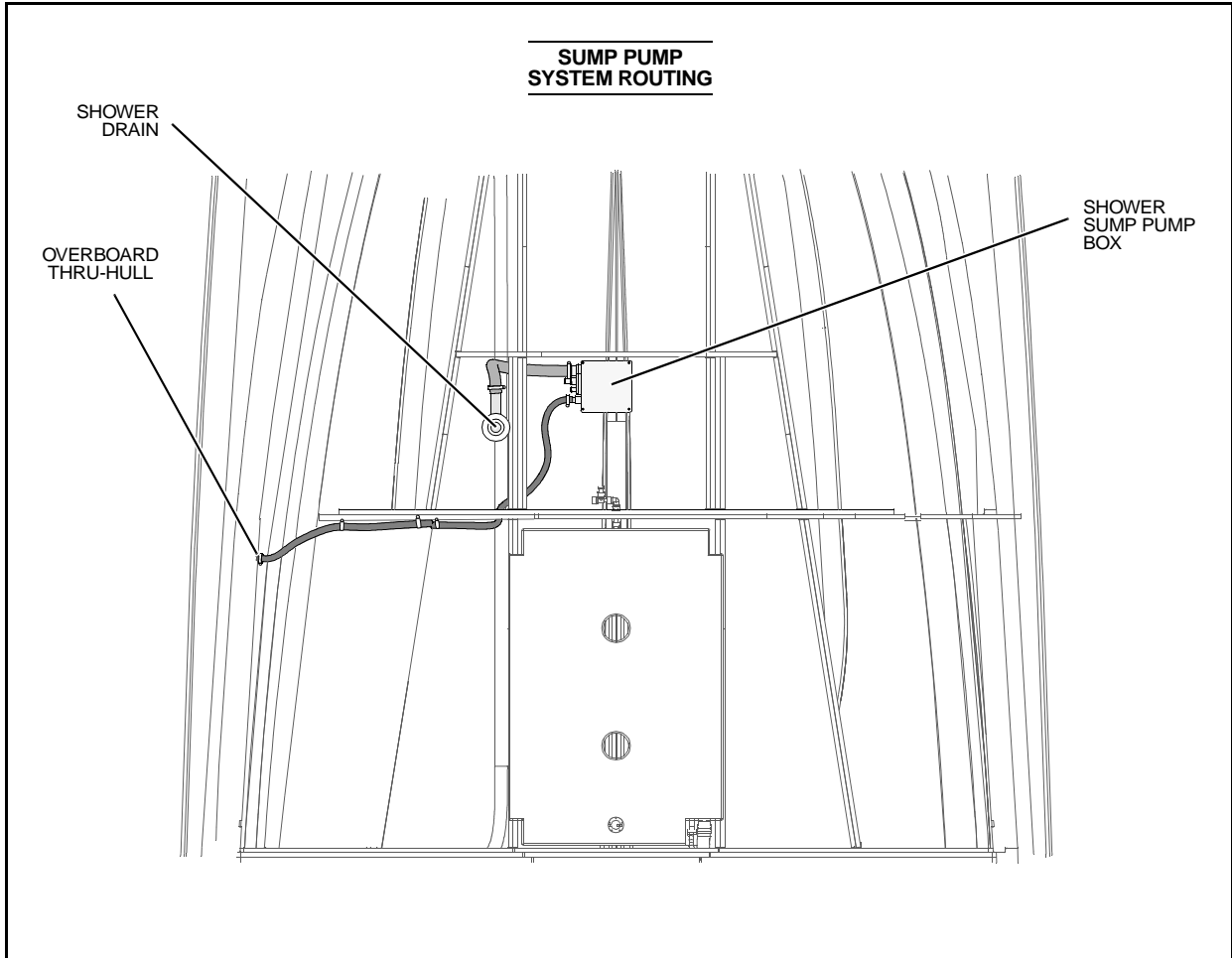

## Seawater Systems

### Seawater Strainers

Seawater strainers are used in water pickup systems to filter incoming seawater. The seawater strainers, located in the engine room and generator compartment, should be checked regularly for leaks and/or debris. The typical layout is one strainer for each of the following: Engine, **optional** raw water washdown (on washdown system's pump), **optional** generator, and **optional** air conditioning/heating systems.

*Cleaning a seawater strainer:*



### CAUTION!

**FLOODING HAZARD!** Prevent taking on water through the disassembled seawater strainer!

- **CLOSE** the seacock, sending water to the seawater strainer, **BEFORE** disassembling the seawater strainer.
- **Keep the seacock CLOSED** until the seawater strainer is completely reassembled.

1. Make sure the component/system (engine, generator, etc.) that the strainer is connected to is turned *off*.
2. *Close* the seacock that sends water to the strainer you are about to clean. The seacock *must* remain closed until the strainer is completely reassembled.
3. Take apart the seawater strainer and remove debris.
4. Reassemble the seawater strainer.
5. Open the seacock *before* turning on the component/system.



### CAUTION!

**SYSTEM DAMAGE HAZARD!** After reassembling the seawater strainer, verify that the seacock valve is *open* before component/system operation.

### Seawater Washdown (Option)

The outlet for the raw water (seawater) washdown system is located on port side of the forward deck. Always make sure the seacock is open before turning the raw water washdown system on. The seacock is accessed through the v-berth floor cutouts.

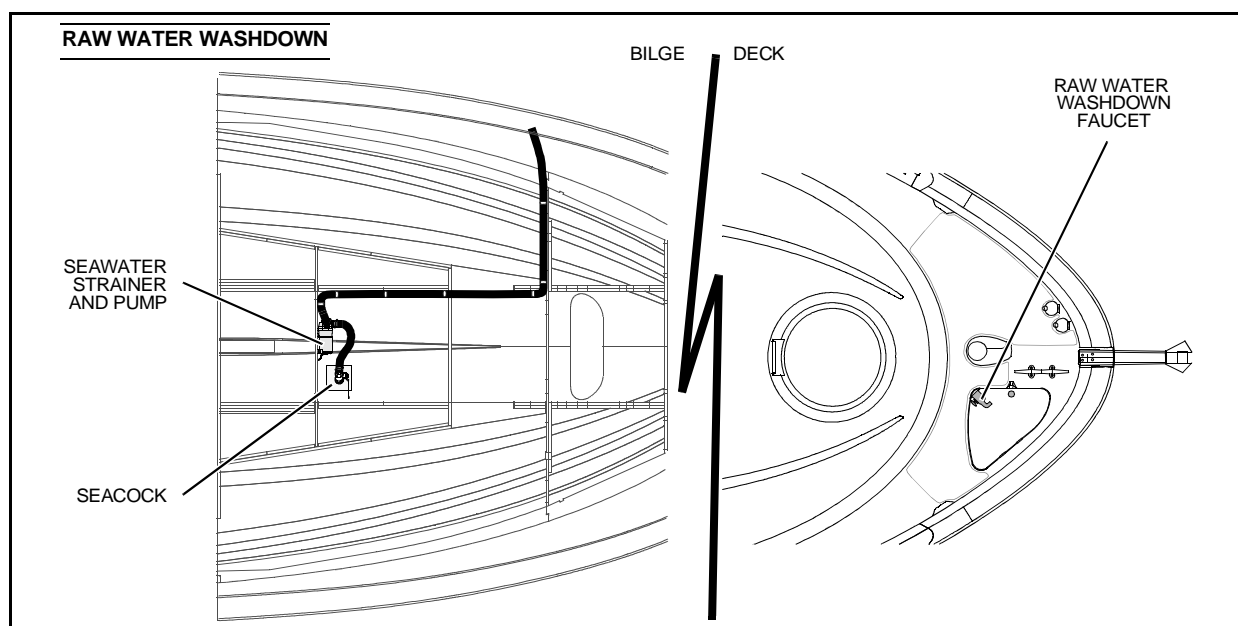



## Air Conditioner & Heater (Option)

Your yacht may be equipped with an **optional** air conditioning (AIR/COND) and/or heating system.

- Before using the air conditioning and heating unit, make sure the breakers on the AC panel are activated.
- Make sure the air conditioning system's seacock is open before using the air conditioning/heating system. The seacock *must* remain open anytime the air conditioner/heater is in use.
- For further instructions, read the air conditioner and heater manual included in your yacht's owner's packet.

**⚠ CAUTION!**

**SYSTEM DAMAGE HAZARD!** Before operating the air conditioning and heating system, verify the system's seawater pickup seacock is *open*. The seacock must remain open anytime the air conditioner/heater is in use.

**⚠ DANGER!**



**CARBON MONOXIDE POISONING HAZARD!**  
Dangerous carbon monoxide gas (CO) can be brought into the boat through the air conditioning system.

### Air Conditioning Pickup Routing:

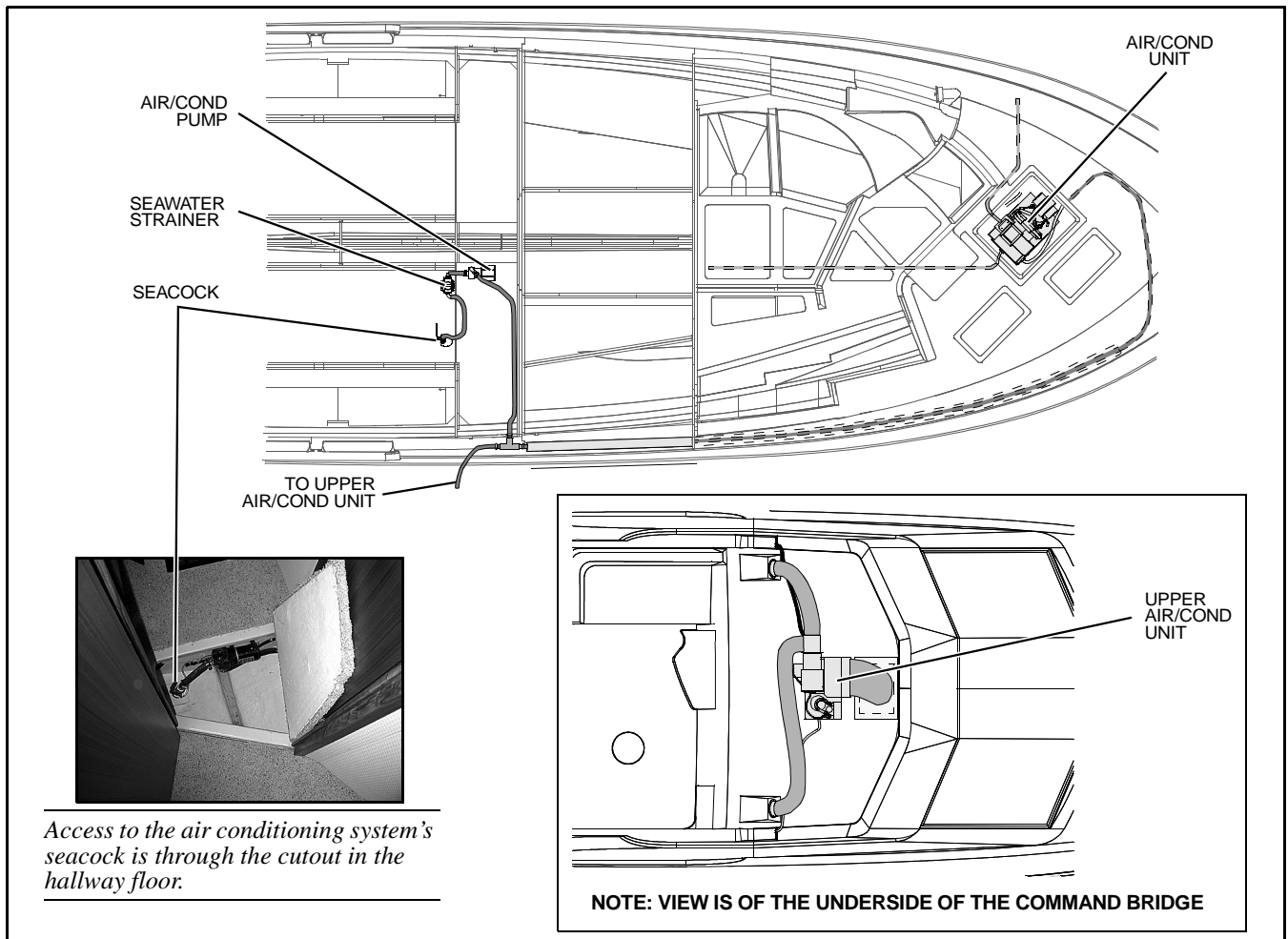

*Access to the air conditioning system's seacock is through the cutout in the hallway floor.*

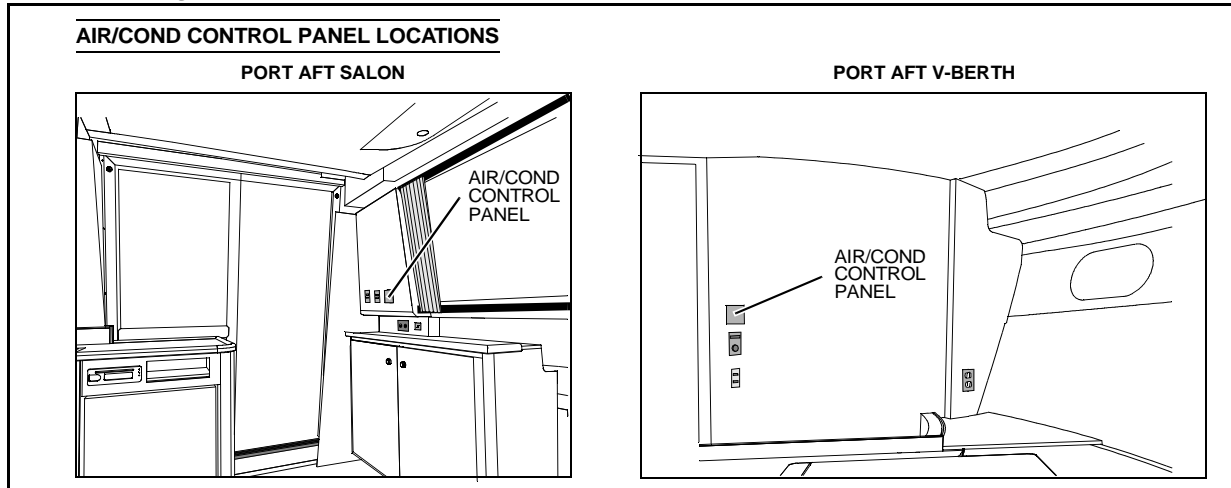
**Air Conditioning Control Panel Locations:****Electric Heaters (Option)**

Your yacht may be equipped with **optional** electric cabin heaters. Operating instructions for this system can be found in the manufacturer's instruction manual included in your yacht's owner's packet.

- Before using the electric heaters, make sure the breakers on the AC panel are turned on.
- The thermostat control is located on the port bulkhead of the salon
- For further instructions, read the manufacturer's instruction manual included in your yacht's owner's packet.

**Heat Exchanger Cabin Heater (Option)**

Your yacht may be equipped with an **optional** heat exchanger cabin heater. This heater runs directly off the port engine.

- Before using the heater, make sure the circulation loop shut off valve is open. This valve can be accessed through the floor cutout in the salon.
- For further instructions, read the manufacturer's instruction manual included in your yacht's owner's packet.
- The circuit breaker for the heater fan is on the main DC panel and must be on to enable the heater fan's 3-position switch (see below for location).
- If the heater's circulation loop is open and the port engine is running, the heater will radiate heat even with the fan turned off.
- All circulation to the heater can be shut off by closing the shut-off valve that can be accessed through the floor cutout in the salon midberth.

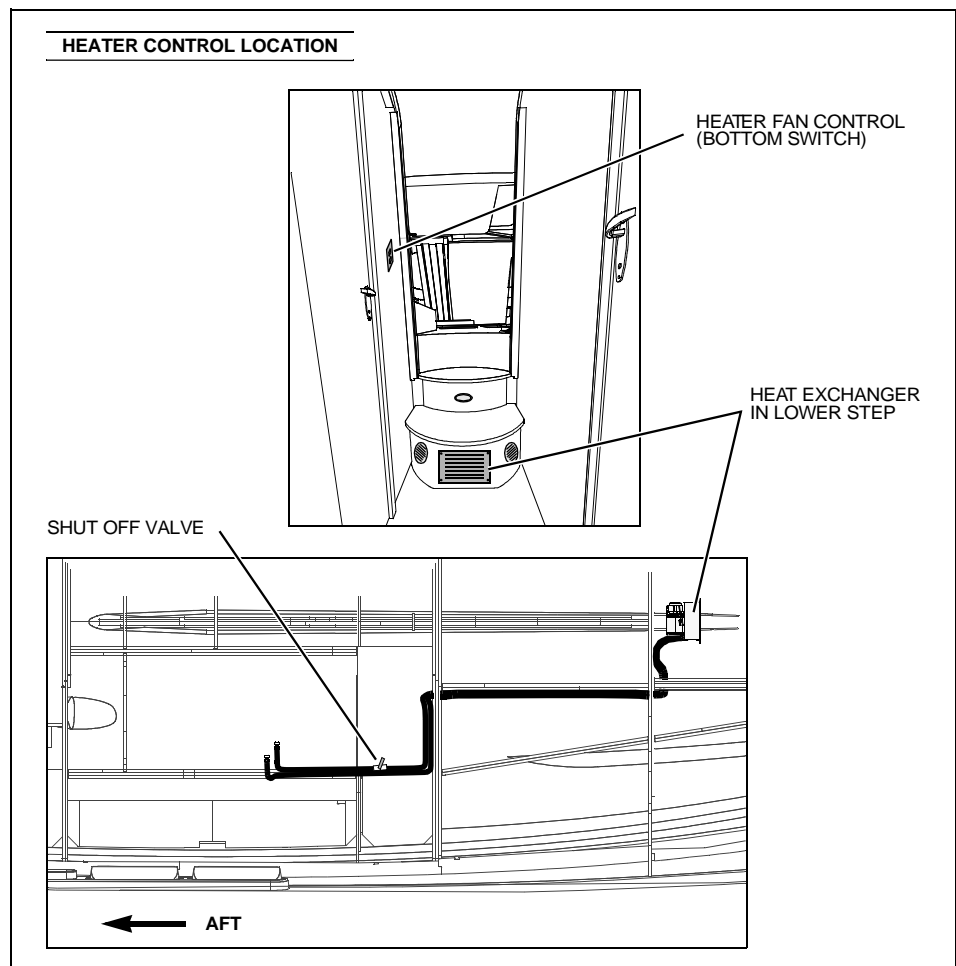

## Marine Head System with Holding Tank

Each head (toilet) comes with its own instruction manual that is included in your owner’s packet. Read the head manual thoroughly before operating your standard manual flush head system or **optional** electric flush head system or **optional** vacuum flush head system and refer to it for winterizing recommendations.

- The marine head system installed on your yacht is designed so that waste from each head is flushed into the holding tank.

**⚠ CAUTION!**

**SYSTEM DAMAGE HAZARD!** Before operating the standard electric head system, make sure the system’s seawater pickup seacock is *open*. The seacock must remain open anytime the head system is in use.

- The holding tank can be emptied by dockside pump-out or, where permitted, dumped overboard by turning on the macerator pump from the pilothouse DC panel. The overboard discharge seacock and the holding tank are located under the stairs leading up to the forward stateroom. The stairs lift out to provide access.
- The holding tank features a level indicator, located on the DC panel. Empty the tank at every opportunity. The indicator is not precise. To prevent possible illegal spillage of waste, avoid filling the holding tank to capacity.
- Make sure the seacock is open before using the standard electric head. The seawater intake seacock for the standard head system is located under the lift out stairs that lead to the forward stateroom.
- Your yacht may feature an **optional** vacuum head system which includes two vacuum generators. The **optional** vacuum head system uses water from the fresh water tank to flush the heads and does not have a seawater intake seacock.

**NOTICE**

**Check local regulations regarding the legal use of marine head systems in your area.**

### Waste System Routing (Electric Option)

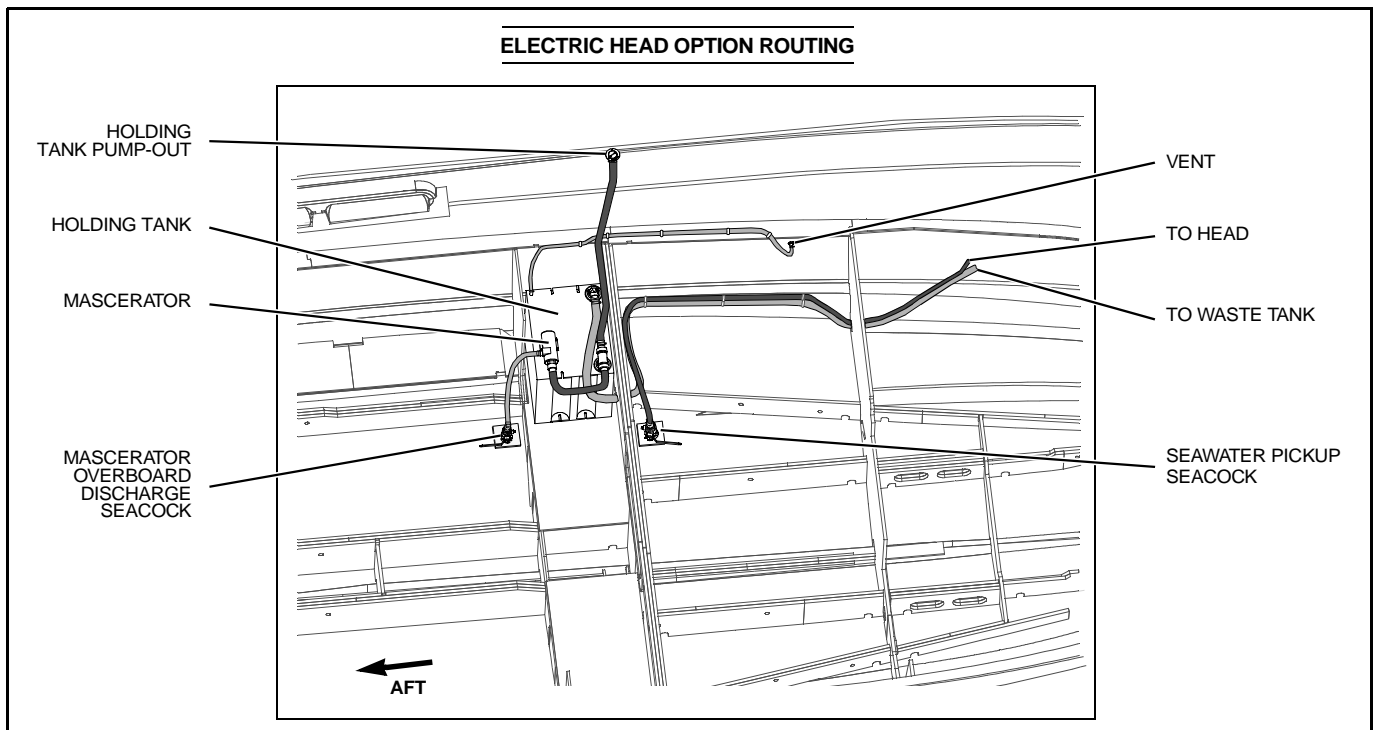

**Waste System Routing (Vacuflush Option)**

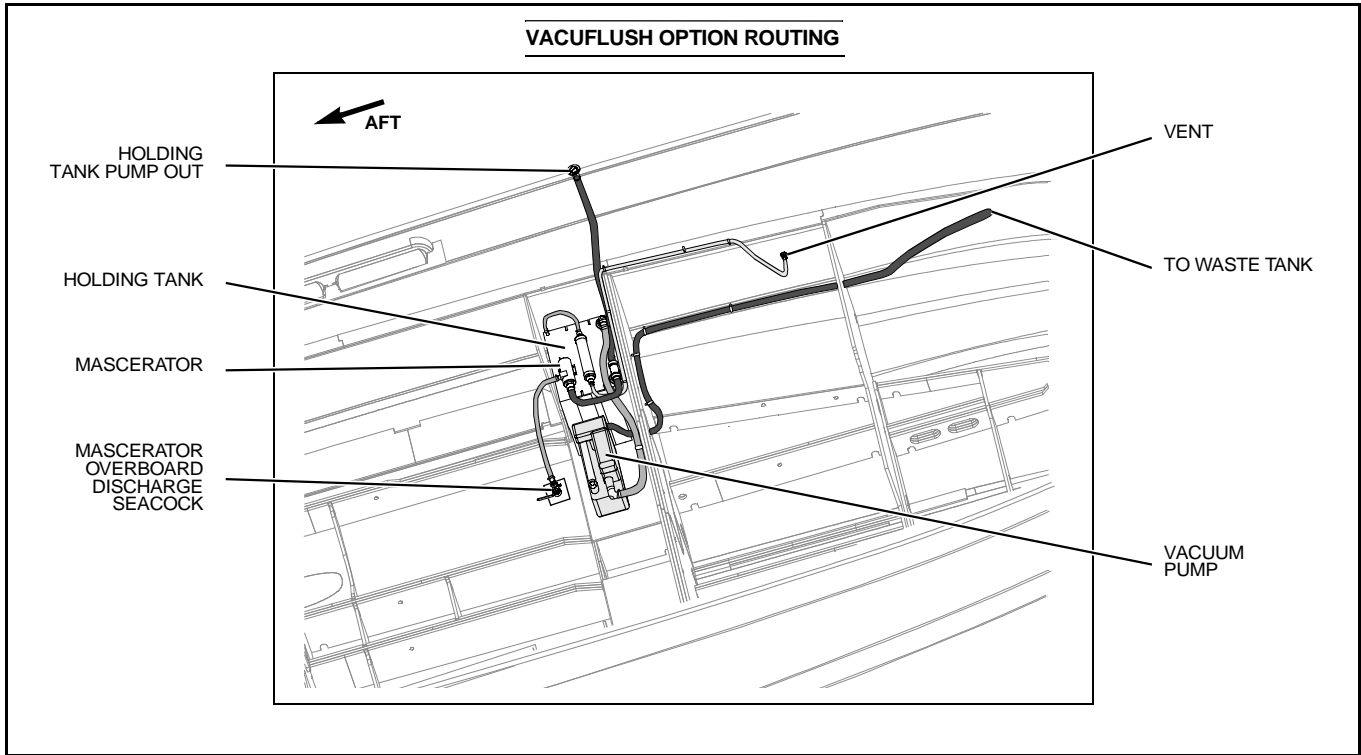

**Vacuum System (Option)**

Your yacht features an **optional** built-in vacuum system. The vacuum hose receptacles are conveniently located on the port side of the stairs leading down to the berths and inside the utility room. The dust collection bag is in the main unit in the utility room. Access is through the mid-berth wall cutout.

- Before attempting to operate the vacuum, make sure the breaker switch on the AC master panel is turned *on*. Refer to the vacuum operation manual included in your yacht’s owner’s packet for further instructions.

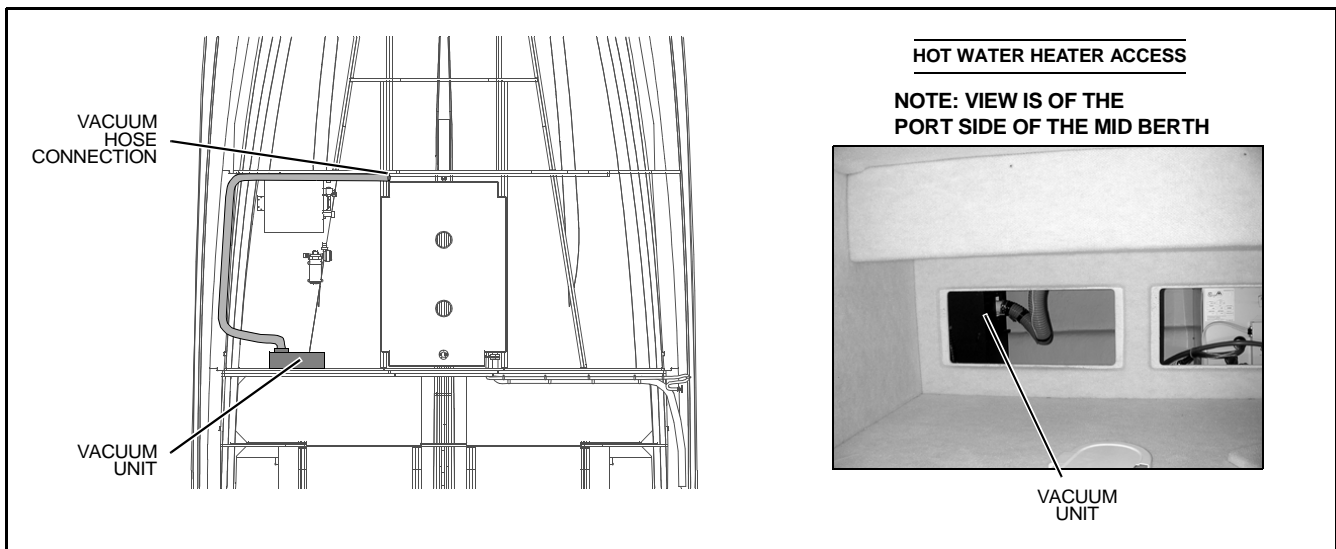

## Electrical System

Read and understand this chapter and the electrical section of the *Owner's Manual*. Electrical routing drawings are provided in Appendix A of this manual; wiring schematics in Appendix B.

**⚠ DANGER!**



**EXTREME FIRE, SHOCK & EXPLOSION HAZARD!**

- To minimize the risks of fire and explosion, *never* install knife switches or other arcing devices in the fuel compartments.
- *Never* substitute automotive parts for marine parts. Electrical, ignition and fuel system parts were designed and manufactured to comply with rules and regulations that minimize risks of fire and explosion.
- *Do not* modify the electrical systems or relevant drawings.
- Only qualified personnel should install batteries and/or perform electrical system maintenance.
- Insure that all battery switches are in the *off* position before performing any work in the engine spaces.

**⚠ WARNING!**



**FIRE, & EXPLOSION HAZARD!**

- Fuel fumes are heavier than air and will collect in the bilge areas where they can be accidentally ignited. Visually and by smell (sniff test), check the engine and fuel compartments for fumes or accumulation of fuel. Always operate the bilge blowers for at least four minutes prior to engine starting, electrical system maintenance or activation of electrical devices.
- Minimize the danger of fire and explosion by not exposing batteries to open flame or sparks. It is also important that no one smoke anywhere near the batteries.

**⚠ CAUTION!**



**SHOCK & ELECTRICAL SYSTEM DAMAGE HAZARD!**

*Never* disconnect the battery cables while the engine is running since it can cause damage to your boat's electrical system components.

**NOTICE**

Electrical connections are prone to corrosion. To reduce corrosion-caused electrical problems, keep all electrical connections clean and periodically coat them with a product specifically designed to control and prevent corrosion.

## 12-Volt DC System

### Fuses and Circuit Breakers

Circuit breakers for main accessory power are located in the AC/DC cabinet (port side of salon). Additional circuit breakers are located on the starboard side of the upper helm station. Some equipment, such as depth finders and shower pumps may have secondary fuse protection at the unit. Bilge pump and windlass circuit breakers are located with the main battery switches in the salon floor.

### Battery Switches

The battery switches are located on the port side of the salon in the AC/DC cabinet. A separate rotary battery switch is provided for each battery. In addition, a parallel switch is provided at each helm to enable you to start the engines using all engine batteries in the event that engine battery power is low.

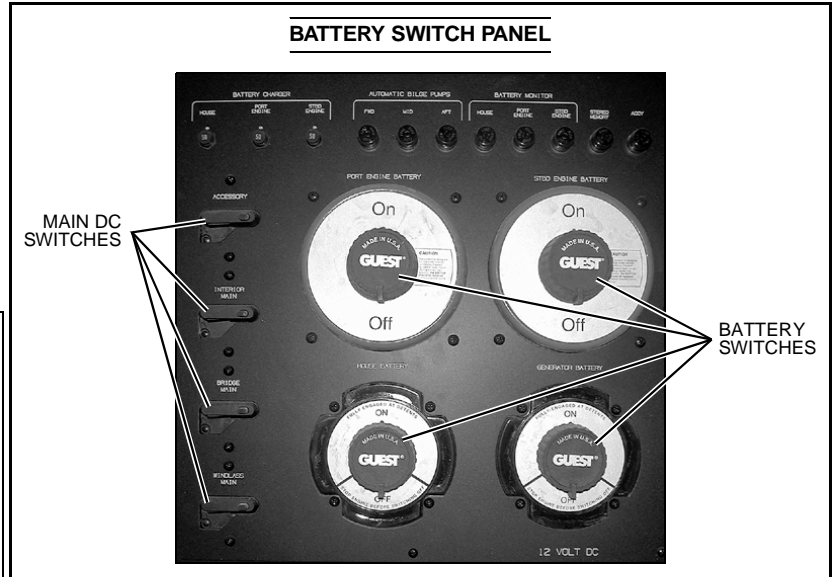

**CAUTION!**

- The parallel switch should be turned on *only* in emergencies.
- *Never* disconnect battery cables or turn off main battery switches while engines are running as this can cause damage to your boat's electrical components.

### Batteries

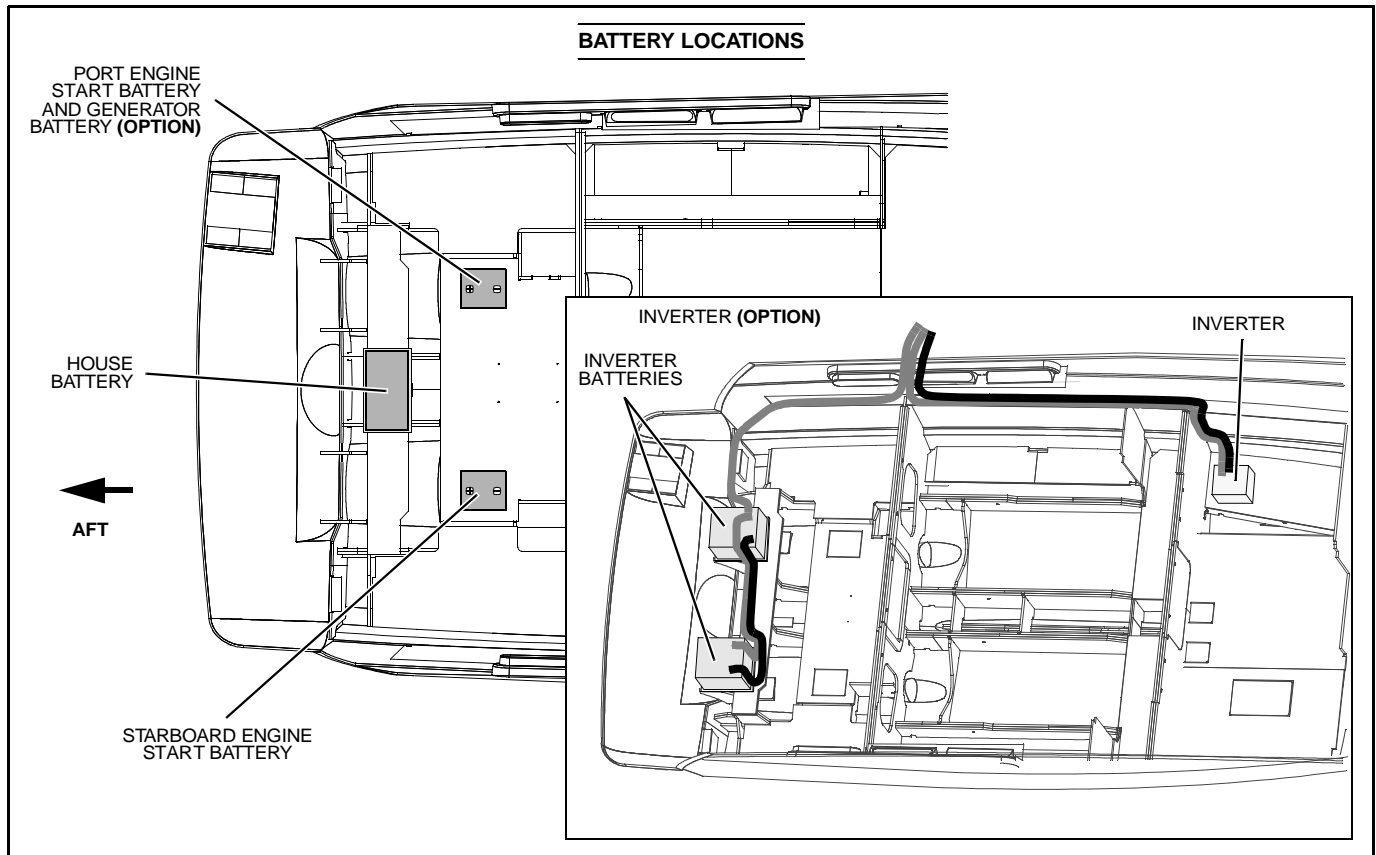

The batteries supply electricity for lights, engine and generator starting, as well as power to turn on accessories. Remove the battery caps and check the electrolyte level every 30 days or more frequently in hot weather. Add distilled water to the cells if necessary.

Corroded battery terminals can be cleaned with baking soda and water. After cleaning the terminals, coat them with a light film of battery terminal lubricant and tighten all battery connections.

Battery condition can be checked on the “Electrical System Monitor” located on the DC distribution panel in the AC/DC cabinet on the port side of the salon.

### Engine Alternators

The engine alternators will maintain proper charge levels in the engine and accessory batteries (some situations may require running the engines at 1200 RPM to initiate charging).

### Battery Charger

In addition to the engine alternators, your yacht is equipped with a battery charger. Thoroughly read and understand the battery charger manual, provided in your yacht’s owner’s packet, before using the charger. The battery charger is located in the utility room. The circuit breaker for the battery charger is located on the salon electrical cabinet and must be turned *on* for charging to occur.



## CAUTION

The battery charging systems (alternator and battery charger) installed are designed to charge conventional lead-acid batteries. Before installing gel-cell or other new technology batteries, consult with the battery manufacturer about charging systems requirements.

## AC Electrical System

- Your yacht uses 120v AC/60Hz A system.
- The AC system can be energized by shore power, **optional** inverter power or **optional** generator power.
- The master circuit breakers, located on the AC panel, provide power source selections to AC powered accessories. Individual breakers *must* be turned on to supply power to the accessories you wish to use.
- This system is designed so that ship’s power and shore power sources *cannot* supply power at the same time.
- The AC panel may contain inactive circuit breakers for accessories that are not available for this model yacht.

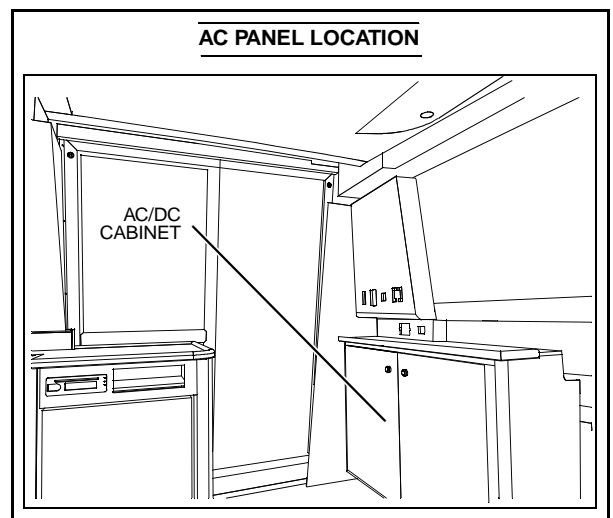

## CAUTION!

### WATER HEATER DAMAGE HAZARD!

- **DO NOT** energize the AC water heater electrical circuit until the heater is *completely* filled with water. Even momentary operation in a dry tank will damage the heating elements.
- Warranty replacements *will not* be made on elements or tank damaged in this manner.
- The tank is full if water flows from the tap when the hot water is turned on in the galley.

### Shore Power

The shore power receptacles are located on the aft cockpit transom.

- Some dockside installations may not be rated for 30 or 50 amps. You may need to purchase lower amp adapters. Whenever a lower amp adapter is used there will be a corresponding drop in supplied power from the dockside system.
- Before connecting to shore power, ensure all breakers and switches on the AC master panel are in the *off* position and switch off the corresponding shore power breaker, located in the generator compartment.

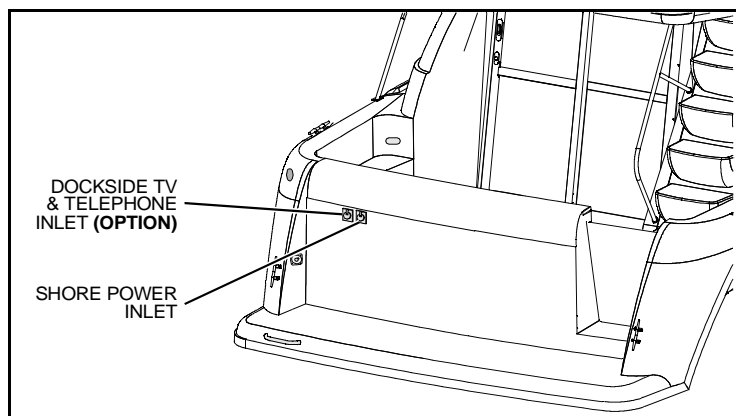

### Connecting To Shore Power

1. Turn OFF all breakers and switches on the AC master panel.
2. Attach the shore power cord to the boat inlet first then to the dockside outlet.
3. Monitor the AC panel's polarity indicator lights, located below the line master breaker(s), as follows:
  - A *green* light illuminating after the power cord is plugged into the dockside outlet indicates acceptable electrical power. You may turn on the master breaker switch.
  - A *red* light, however, indicates reversed polarity, which could cause electrical system damage and possibly electrical shock injuries. In this case, *do not* turn on the master breaker switch (see previous warning).
4. Switch the "Line 1 Dockside Master" ON.
5. Switch the "Line 2 Dockside Master" ON (dual dockside **option** only).
6. Turn ON the individual component breakers as required.

**⚠ DANGER!**



**FIRE, EXPLOSION & SHOCK HAZARD!**

- To minimize shock and fire hazard, *do not* modify electrical systems or relevant drawings.
- *Do not* alter shore power connectors and use only compatible connectors.
- Only qualified personnel should install batteries and/or perform electrical system maintenance.
- Before connecting to shore power, ensure all breakers and switches on the AC master panel are in the *off* position.
- To prevent shock or injury from an accidental dropping of the "hot" cord into the water, *always* attach the shore power cord to the boat inlet first, then to the dockside connection.

**⚠ CAUTION!**



**SHOCK & ELECTRICAL SYSTEM DAMAGE HAZARD!**

- *Never* connect dockside power to your boat outside North America unless you've purchased the international electrical conversion option.
- Use double insulated or three-wire protected electrical appliances whenever possible.



**! WARNING!**

**⚡ SHOCK & ELECTRICAL SYSTEM DAMAGE HAZARD!**

- You must monitor the polarity indicator lights every time you connect to shore power.
- When connecting to shore power and you encounter reversed polarity light (**red** colored), *do not* energize the main breaker switches. Instead, *immediately* disconnect the shore power cord (always from the dockside receptacle first) and notify marina management.

**NOTICE**

- When using shore power, the simultaneous use of several AC accessories can result in an overloaded circuit. It may be necessary to turn off one accessory while operating another.
- Voltage on each line can be read by setting the voltmeter selector switch.
- Amperage draw can be read on the ammeter gauge.

**Inverter Power (Option)**

Your yacht may feature an **optional** inverter. This allows the batteries to supply AC power to some accessories when your yacht is not connected to shore power. The inverter is located in the utility room and can be accessed through the wall cutout in the mid-berth. Primary control is from the Inverter Remote Control Panel, located in the main AC/DC cabinet on the port side of the salon. Redundant controls are available on the inverter itself. Refer to the inverter manual for detailed inverter operating procedures.

- Activate the AC system under inverter power by switching *on* the inverter master breaker (located on the main electrical panel) and pressing the on/off switch on the inverter remote control panel.
- The inverter only provides AC power to the accessories on the AC panel that have white breakers. Individual breakers *must* be activated to supply power to the accessories you wish to use.

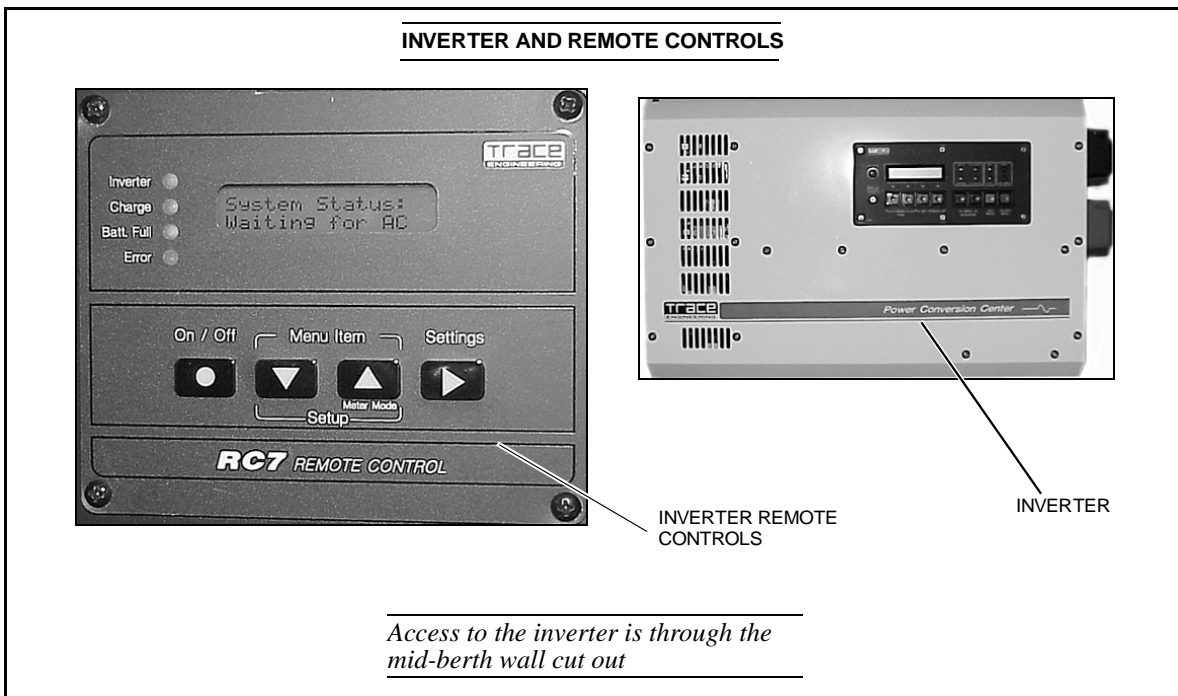

### Generator Power (Option)

Your yacht may be equipped with an **optional** generator. The generator is located in the aft machinery compartment. Access to the generator compartment is through the aft cockpit hatches. Prior to initially operating your **optional** generator read the generator operation manual for pre-start checks and break-in procedures. The manuals are included in your yacht's owner's packet.

⚠ **DANGER!**



***CARBON MONOXIDE POISONING HAZARD!***

**Generators are a source of dangerous carbon monoxide gas (CO). Check the generator exhaust system for leaks before each use.**

#### Observe the following about your generator:

- Polarity has been established in the installation of the generator(s), therefore the polarity lights will not function in this mode.
- Fuel to run the main generator is supplied from the port fuel tank.
- In addition to servicing the filters attached to the generator(s), the filters/separators (located near the fuel line valves) should be serviced as described in the manufacturer's manual.
- The coolant mixture installed at the factory consists of equal parts of water and antifreeze (Ethylene Glycol). The coolant bottle for the generator is located inside port generator compartment hatch.
- Check the generator's seawater strainer for leaks and/or debris before each operation.
- Oil pressure, water temperature, and voltage gauges are provided on the generator control panel, inside the AC/DC cabinet on the port side of the salon. These gauges monitor the engine functions of your generator.

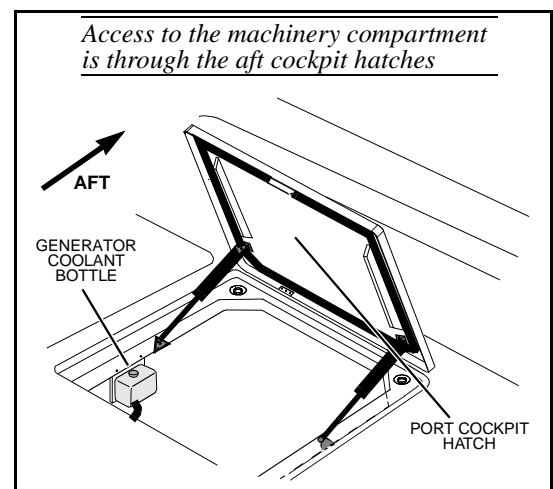

**Starting generator:**

1. Open the generator's seacock valve before starting the generator. *Keep the seacock valve open while the generator is running.*
2. Run the bilge blowers for a minimum of four minutes before starting the generator. Leave the blowers on while the generator is running unless your yacht is up to cruising speed.
3. Make sure the generator's battery switch, located on the main battery switch panel in the salon floor, is turned *on*.
4. On the generator control panel, press and hold the preheat switch for one minute.
5. Continue pressing the preheat switch, and press the start button.
6. As the engine starts, continue pressing the preheat switch until oil pressure is shown on the pressure gauge.

**CAUTION!**

**SYSTEM DAMAGE HAZARD!**

- **Make sure the generator's seawater pickup seacock is in the open position before and during generator use.**
- **Never run the generator starter for more than 30 seconds. If the generator does not start, wait at least 30 seconds before trying again.**
- **After the generator starts, let the generator stabilize before turning on the component breakers on the AC panel.**

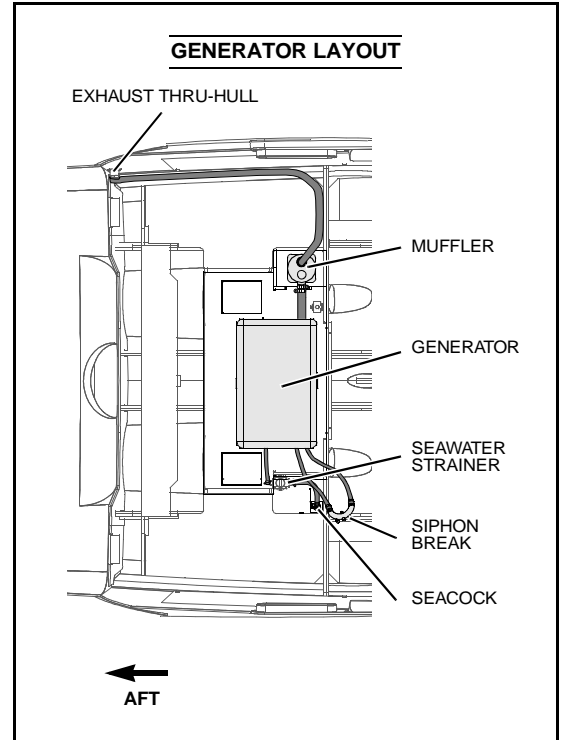

7. On the AC panel:
    - Slide the T-bar left (from shore to generator power).
    - Switch the generator master circuit breaker *on*.
    - Turn on each individual component breaker as required.
  8. To monitor the voltage generated by the generator, switch the shore/generator voltage switch to *generator*.
- To shut off the main generator:** Hold the "stop" switch until the generator shuts down.

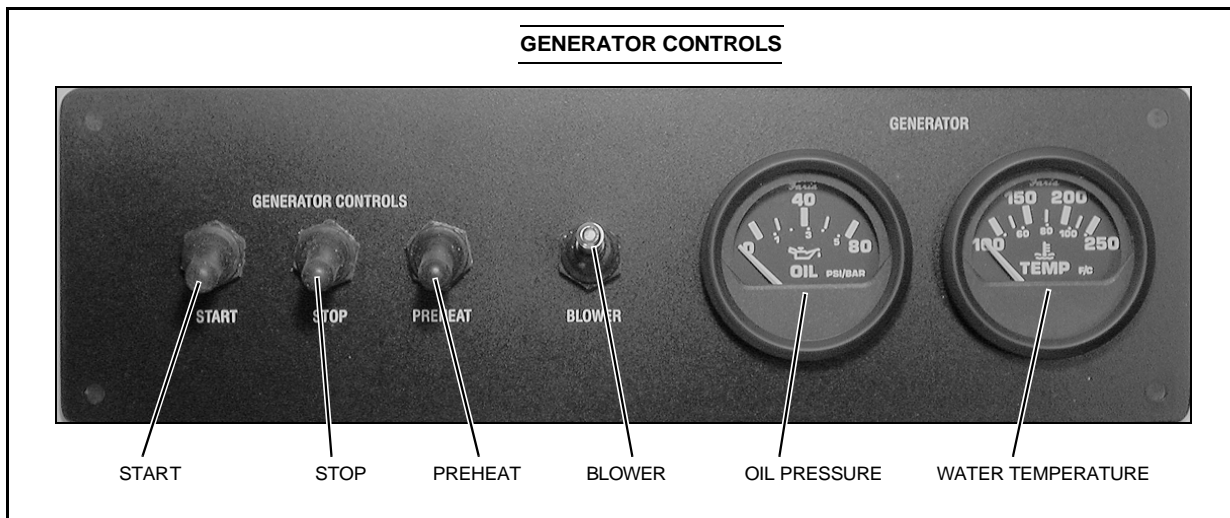

# APPENDIX A: ELECTRICAL ROUTINGS

## Deck Harness Port

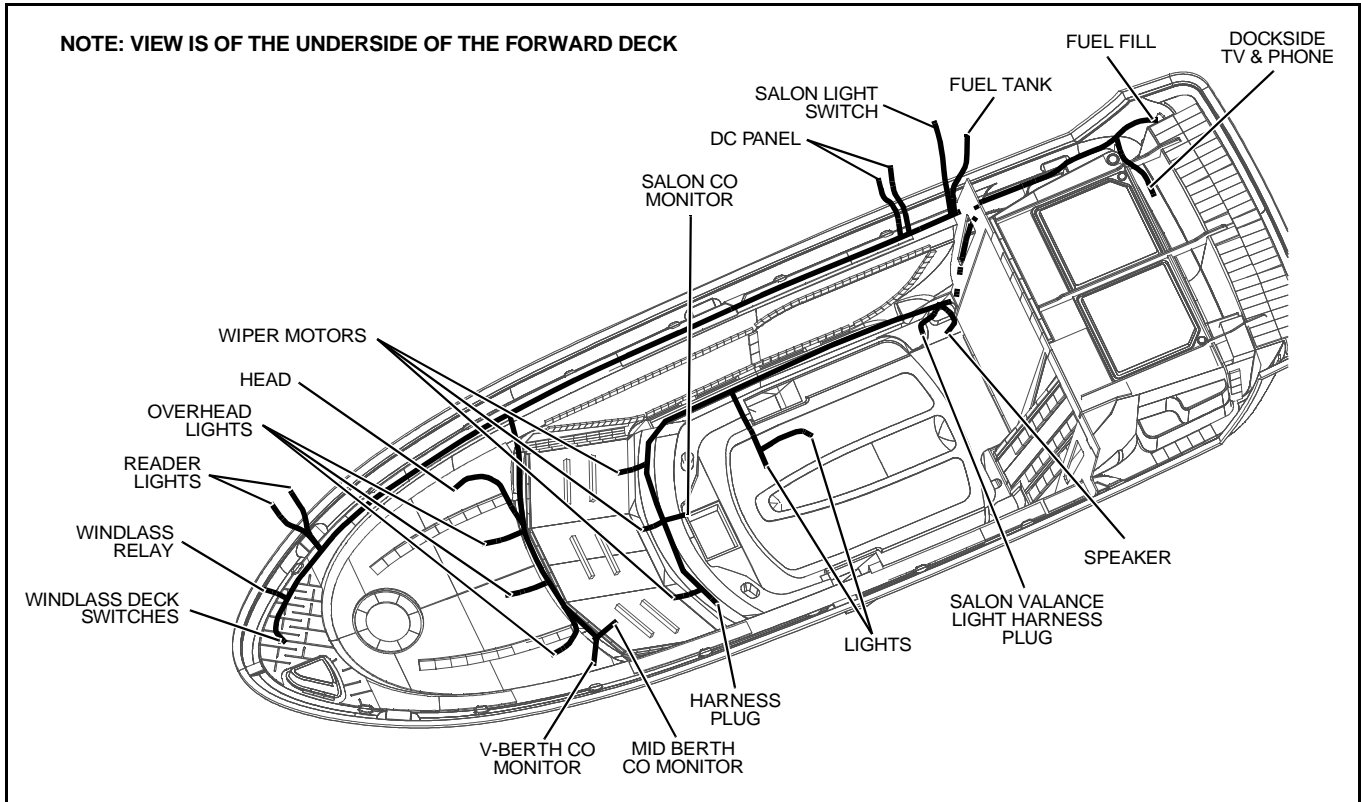

## Deck Harness Starboard

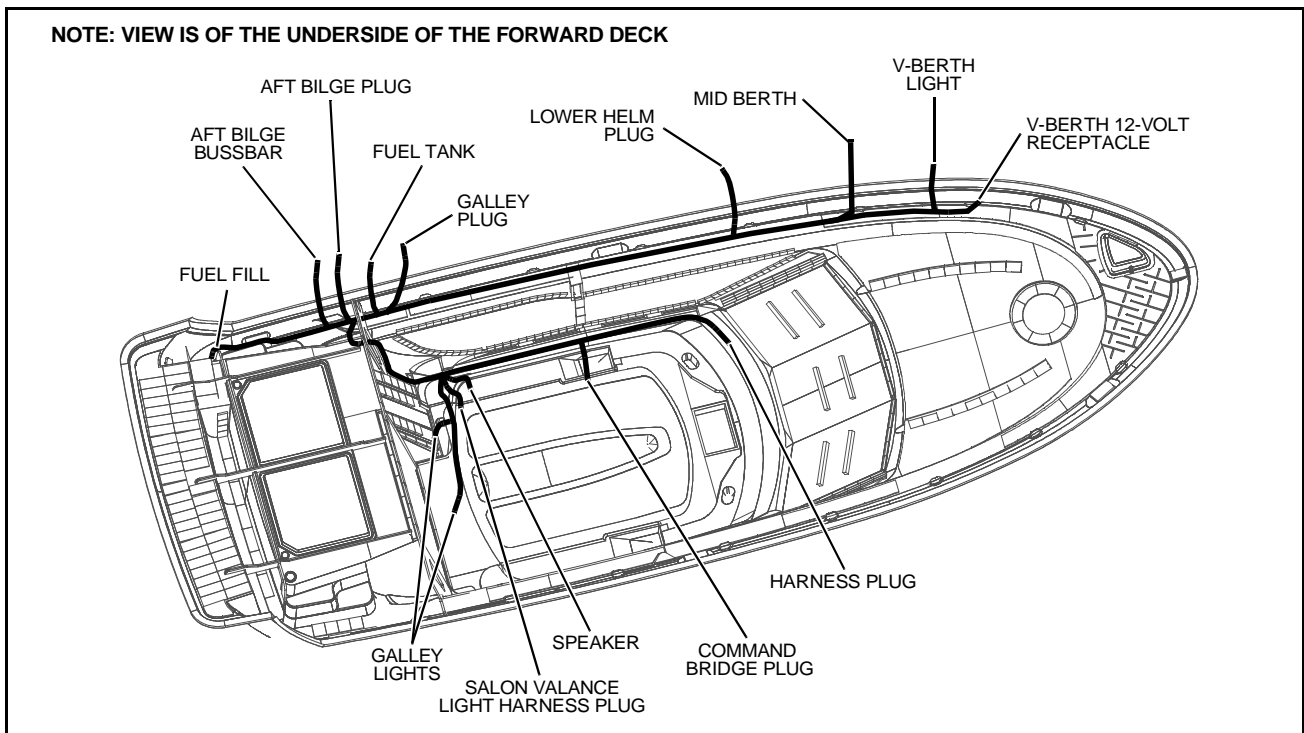

### Windlass Harness

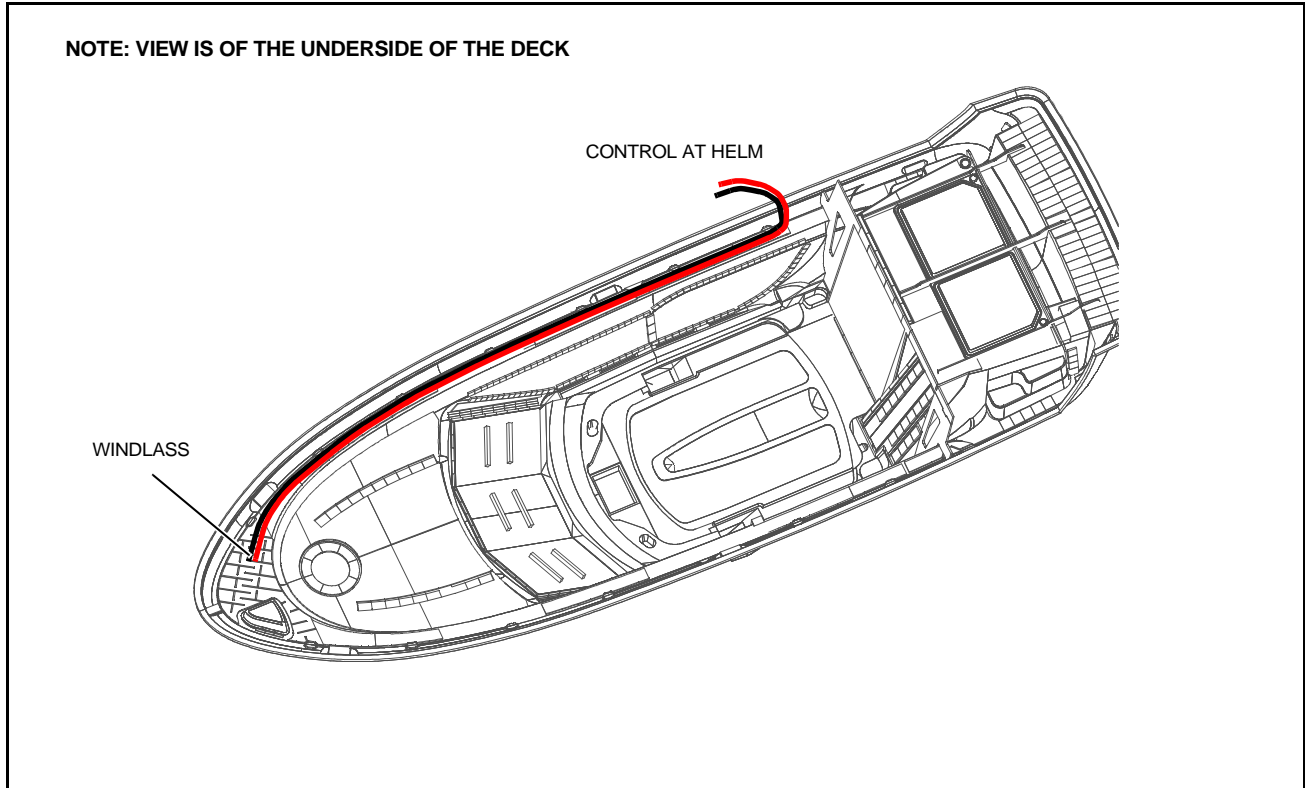

### Bonding Harness Routing

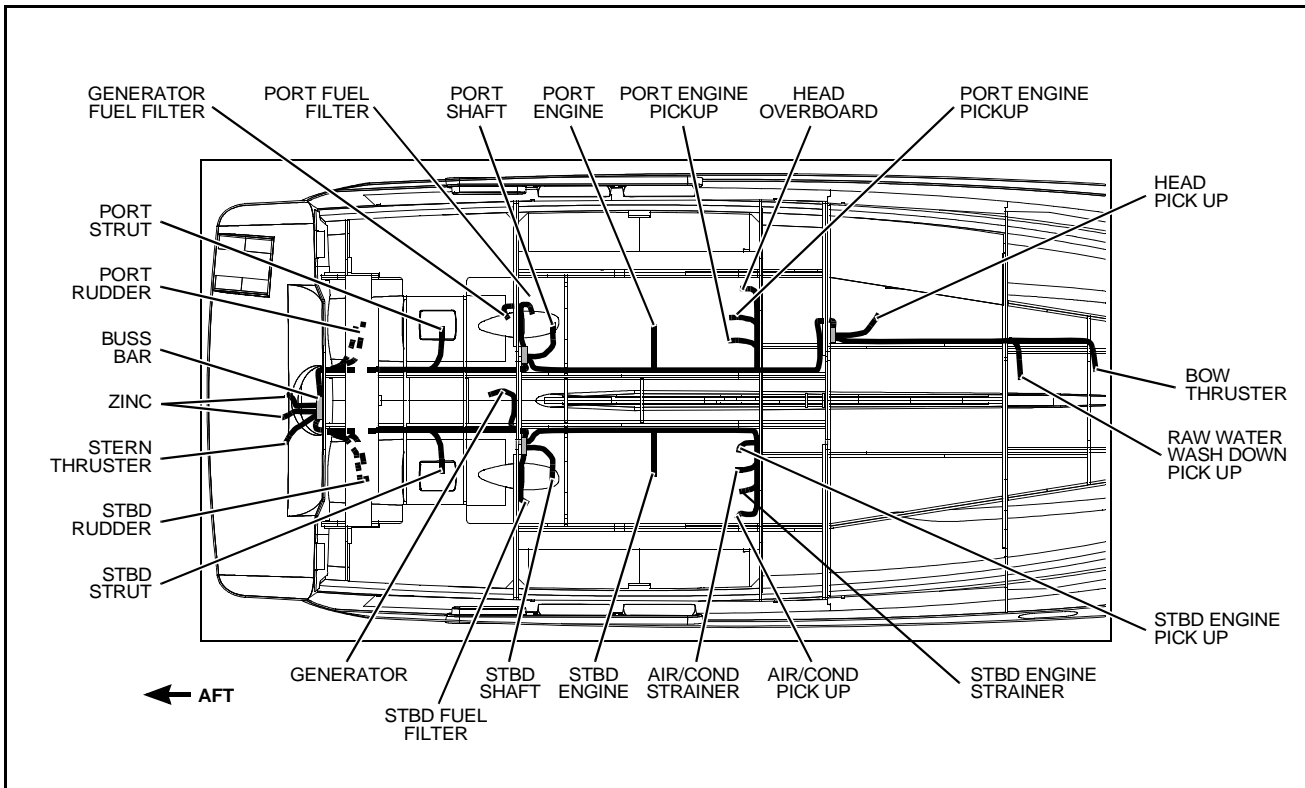

### Forward Bilge Harness Routing

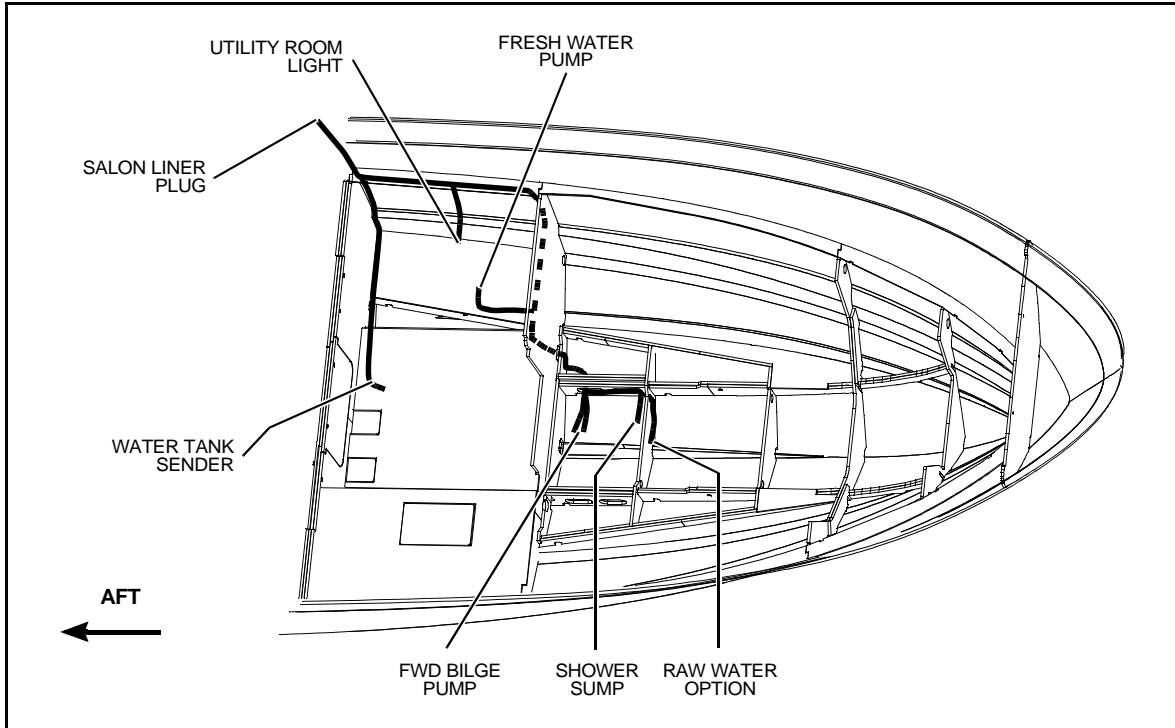

### Forward Bilge Harness Routing

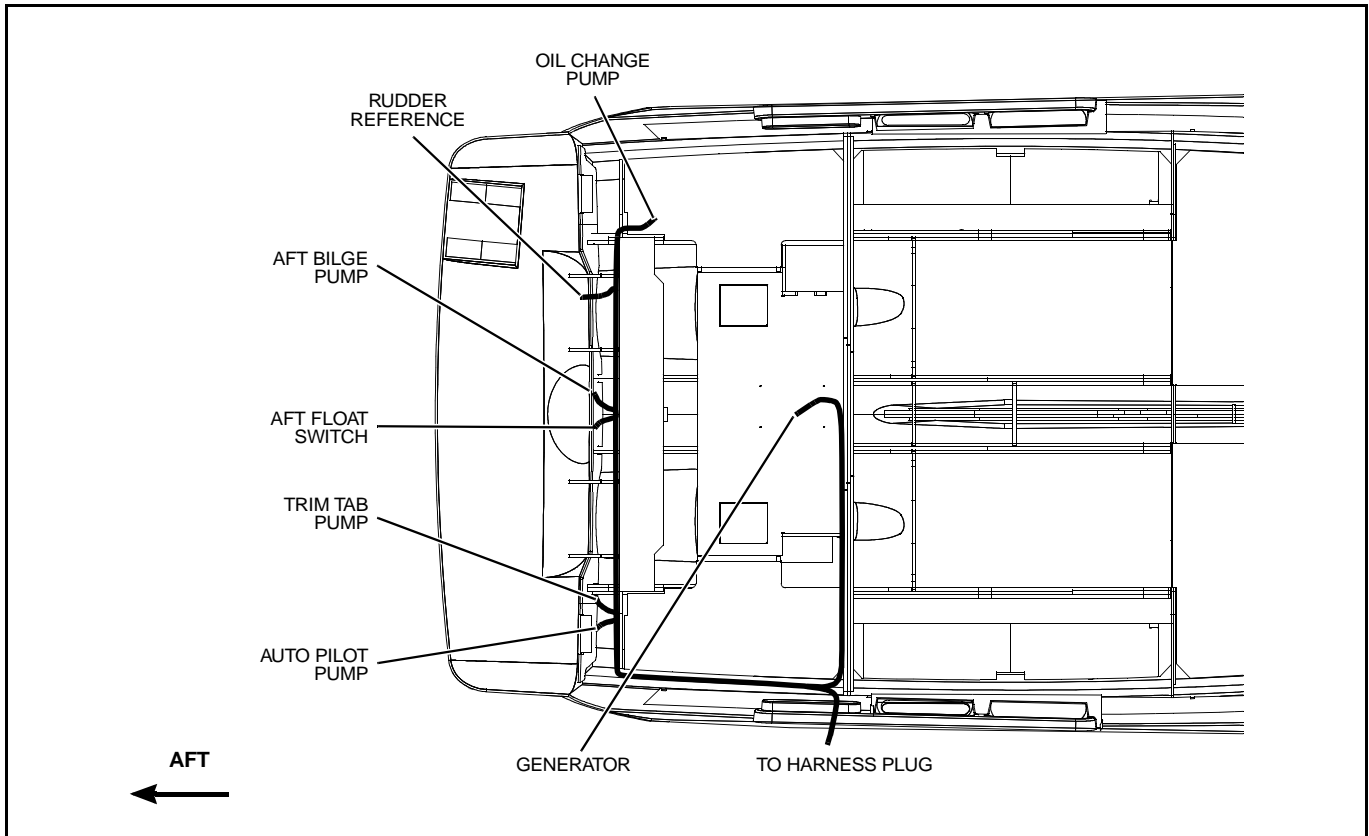

**APPENDIX B: WIRING SCHEMATICS**

**Engine and Helm Control Wiring Diagram**

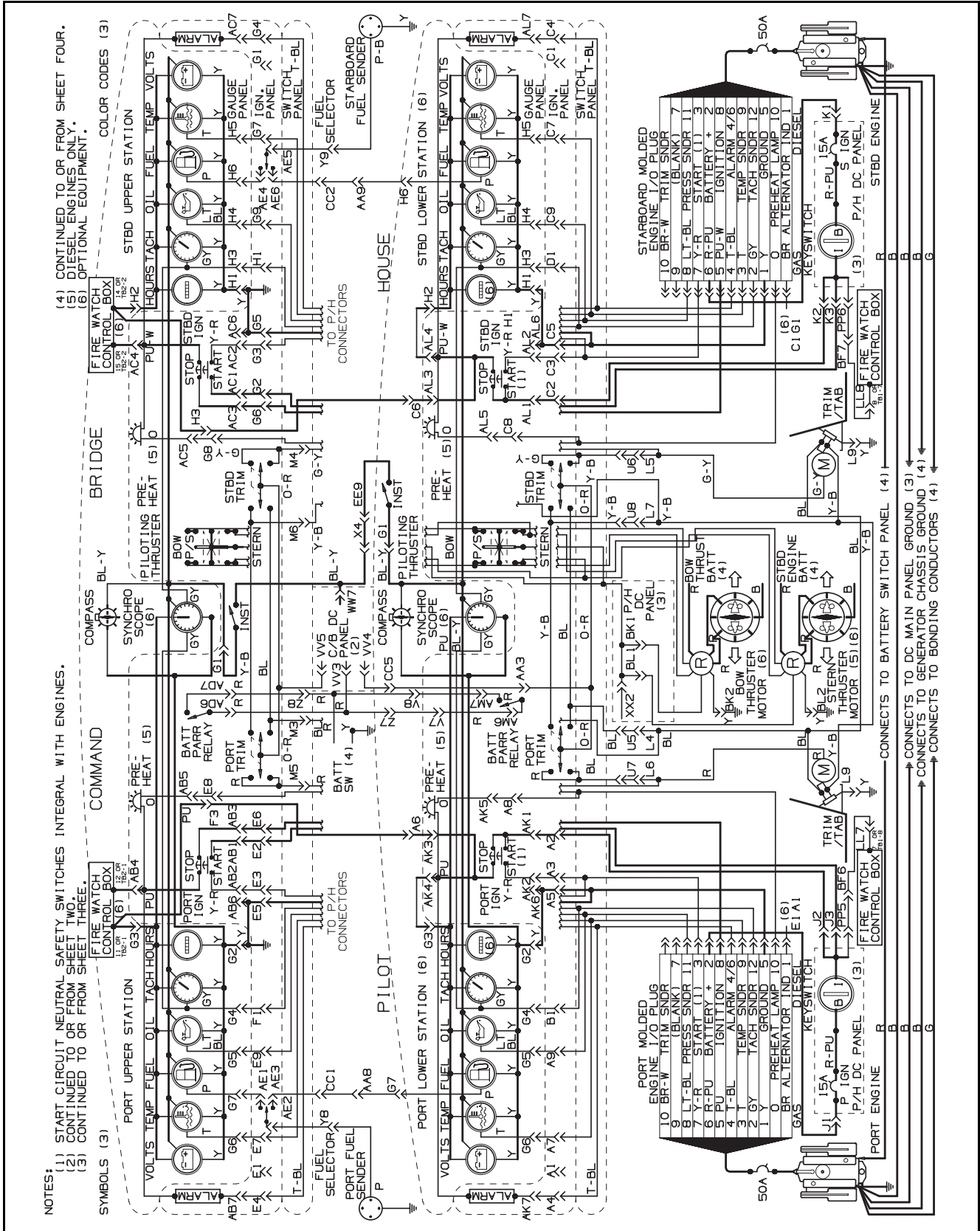

# DC-Distribution System-Command Bridge Wiring Diagram

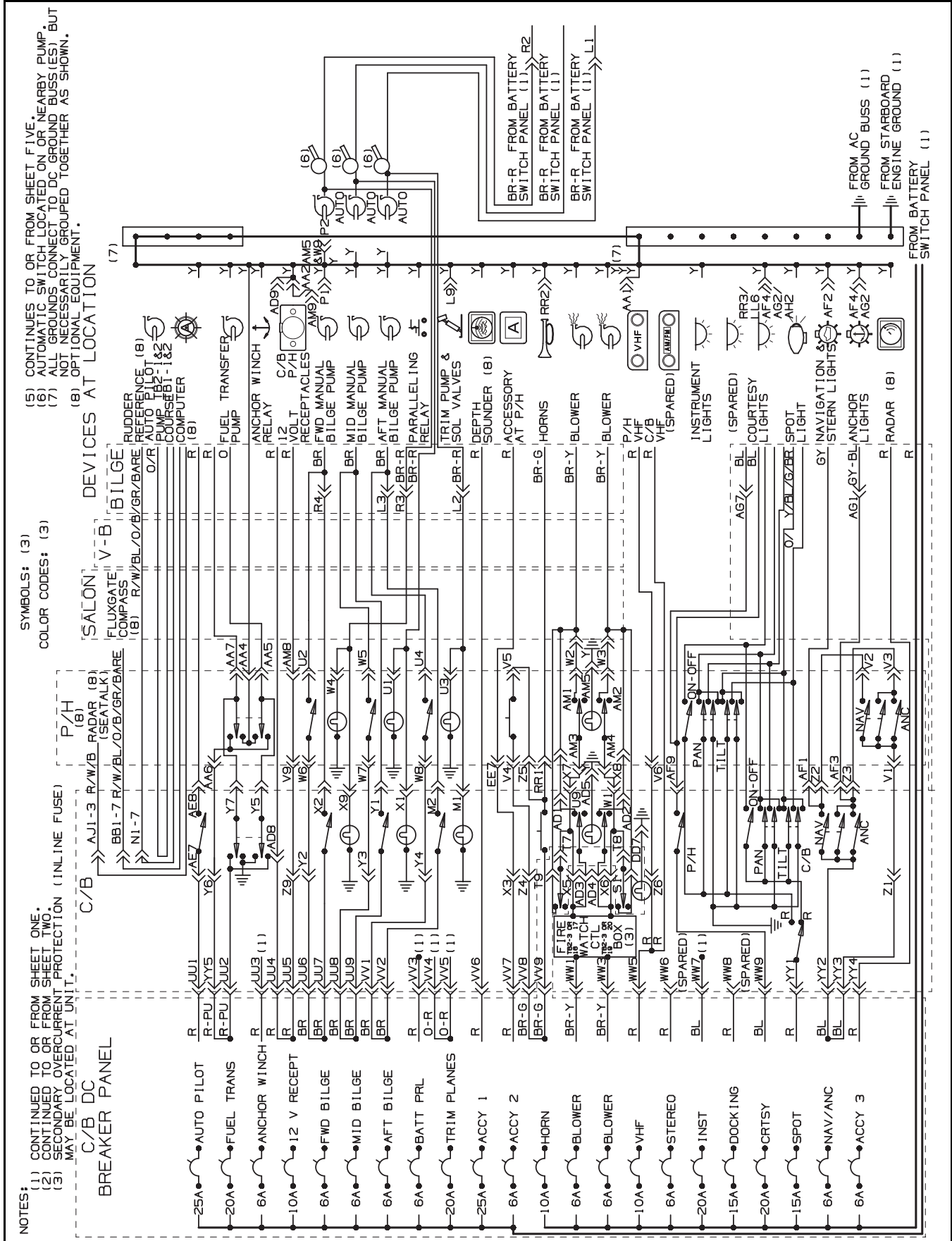



# DC-Distribution System-Pilot House Wiring Diagram

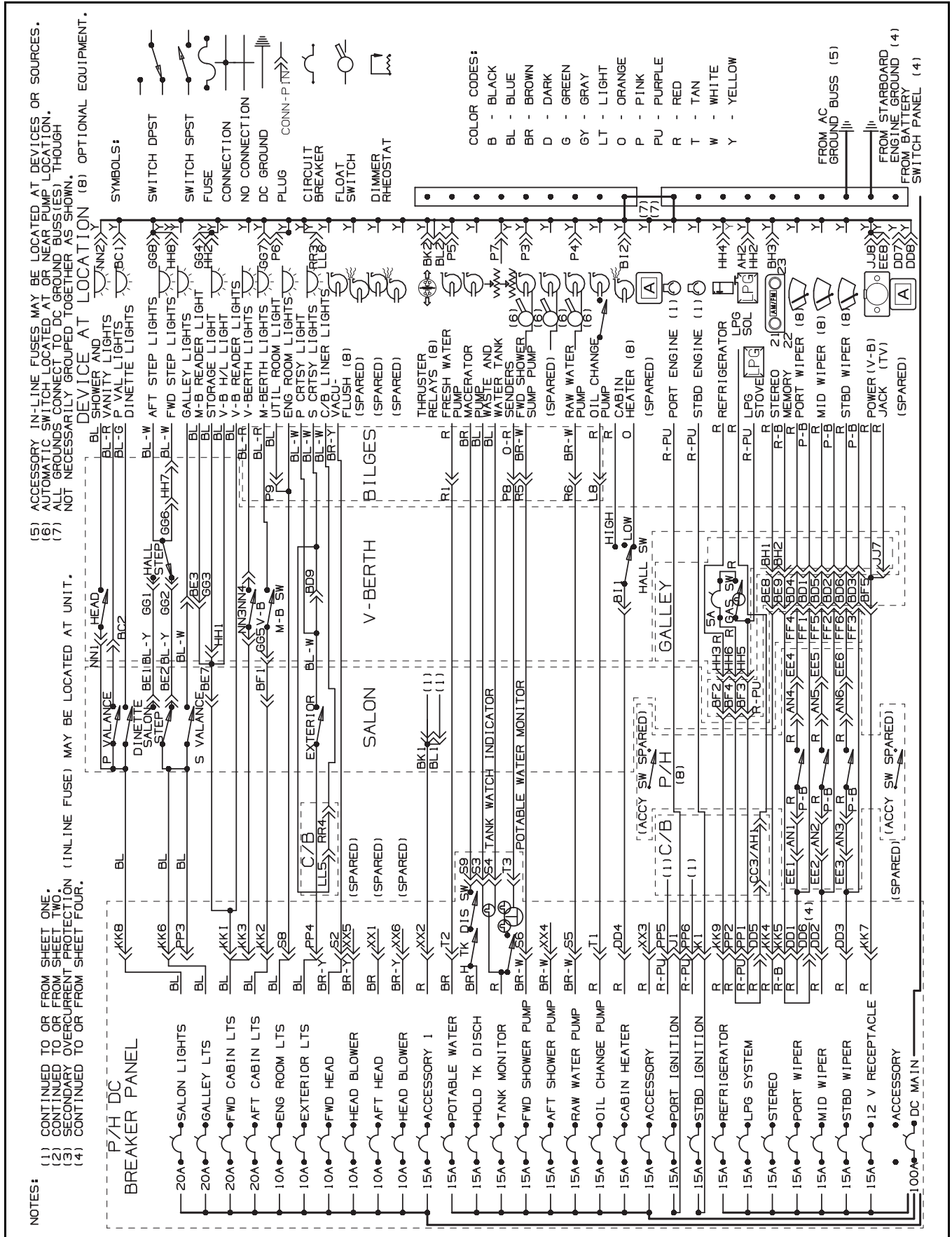

# DC-Auxiliaries and Battery Wiring Diagram

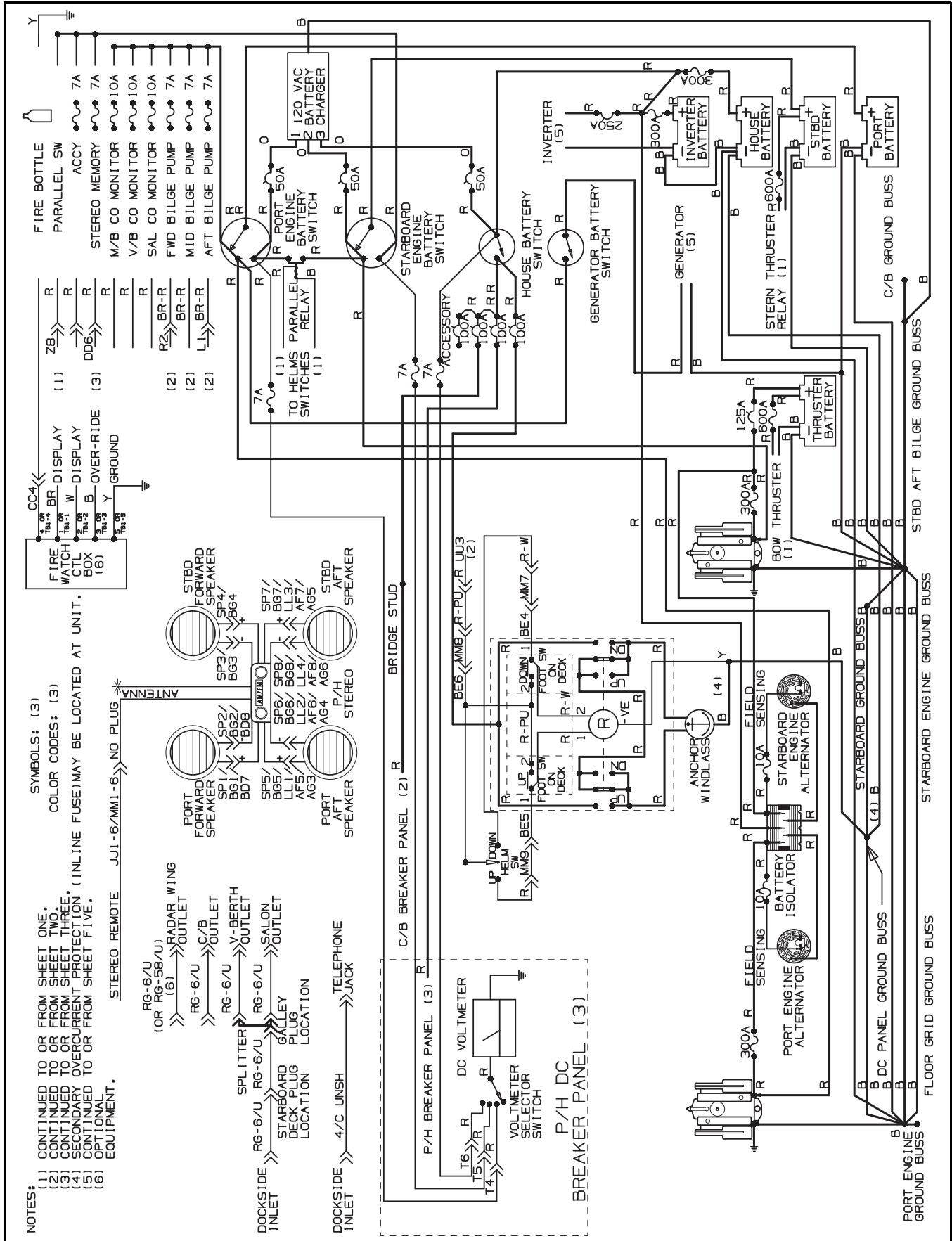

# 120-Volt AC Wiring Diagram

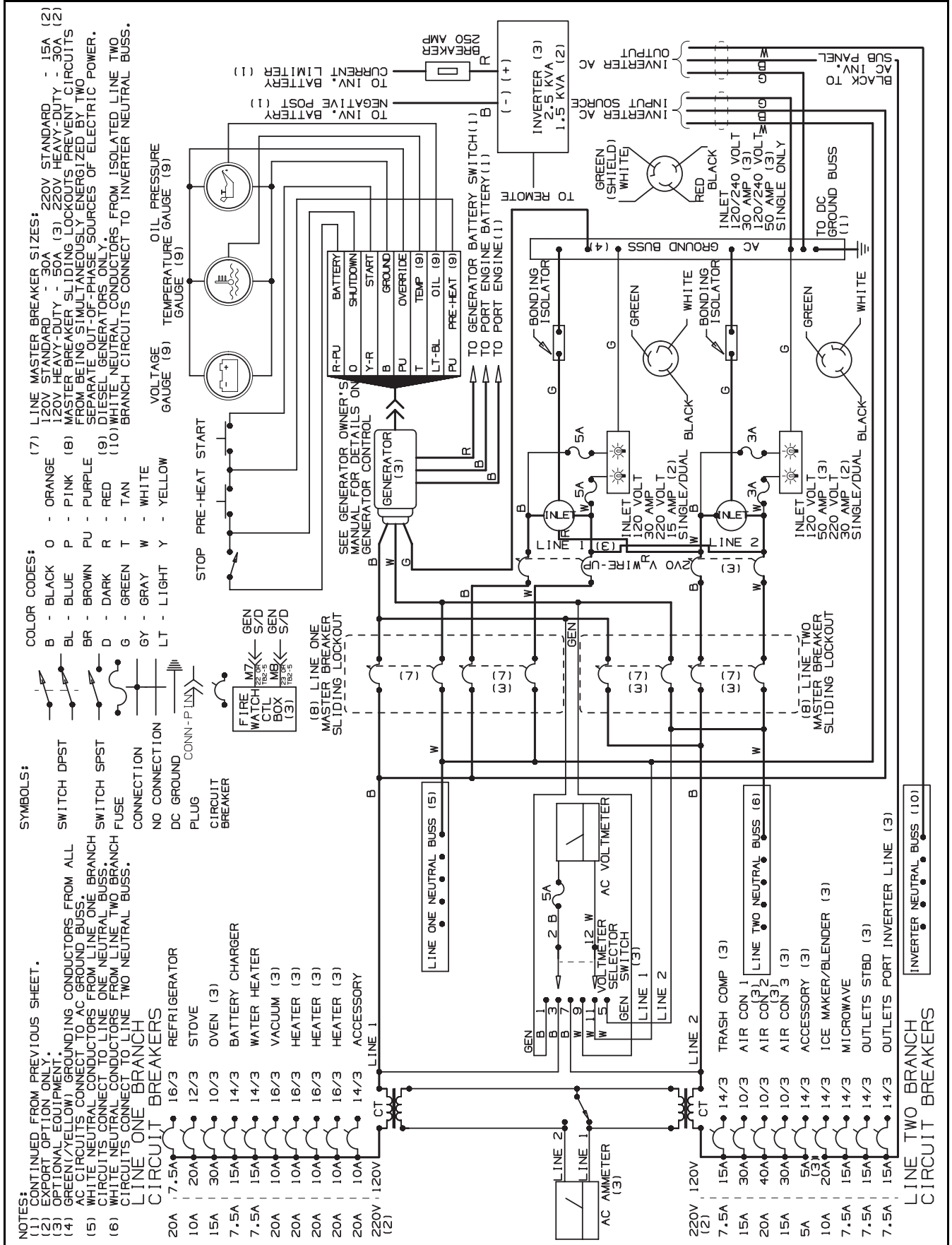

## APPENDIX C: EXPRESS LIMITED WARRANTY

### BAYLINER MARINE CORPORATION, EXPRESS LIMITED WARRANTY

#### Limited Warranty for New 2001 or 2002 Model Year Motoryachts (3488, 3788, 3988, 4087, 4788, 5288 and 5788)

Bayliner warrants to the first retail purchaser ("Owner") of a new 2001 or 2002 Model Year Bayliner Motoryacht (3388, 3788, 3988, 4087, 4788, 5288 and 5788) purchased from an authorized dealer, operated under normal, noncommercial use, that the selling dealer will (or, in Bayliner's discretion, it will):

- (1) repair or replace any parts found to be defective in materials and workmanship occurring within 1 (one) year of the date of delivery;
- (2) repair any defects in materials and workmanship in structural fiberglass parts of the hull (and specifically excluding the deck) occurring within 7 (seven) years of the date of delivery; and
- (3) repair any defects in materials and workmanship that result in osmotic blistering of the exterior gel coat surface of the hull laminate occurring within 5 (five) years of the date of delivery, *except that Bayliner shall not be liable or responsible to correct, repair, or replace any damage from osmotic blistering if the original gel surface has been altered in any way*, including repair or application of any coating other than marine anti-fouling bottom paint or improper surface preparation for paint, or excessive sanding or sandblasting. Bayliner shall repair osmotic blisters based upon customary and reasonable charges with the method and extent of repair subject to Bayliner's prior approval.

Owner's sole and exclusive remedy for defects covered by this limited warranty shall be the repair or replacement, at the option of Bayliner, of the defective part or component. **THE REMEDY DESCRIBED IN THIS LIMITED WARRANTY SHALL BE THE SOLE AND EXCLUSIVE REMEDY PROVIDED BY BAYLINER.**

#### Terms and Conditions

This limited warranty is subject to the specific terms and conditions set forth below.

**In order to receive this limited warranty coverage, Bayliner must receive the limited warranty registration card from the authorized selling dealer within 30 days of delivery of the Motoryacht. Receipt by Bayliner of the limited warranty registration card is a condition to the processing of a warranty claim.**

All repairs under the terms of this warranty are subject to pre-approval from Bayliner service personnel. Employees of Bayliner dealers are not authorized to make warranties or approve warranty repairs other than those set forth herein.

To obtain warranty service, the Motoryacht, including any allegedly defective part, must be returned to the authorized Bayliner dealer from whom the Motoryacht was purchased within the applicable warranty period. All warranty repairs must be performed at the Bayliner dealer's facilities or, at Bayliner's discretion, at an authorized Bayliner repair facility.

The Owner is responsible for all expenses associated with transporting the Motoryacht and/or defective part to and from the Bayliner dealer, expenses associated with haul outs, yard fees, and any other expenses associated with transferring the yacht to the Bayliner dealer or authorized Bayliner repair facility for warranty service.

#### What Is Not Covered

Bayliner shall not be responsible for any condition that may be affected by the Owner's failure to use, maintain, or store the Motoryacht as specified in the Bayliner owner's manual, and any other failure to provide reasonable care and maintenance.

Bayliner hereby assigns all warranties provided by the manufacturers and distributors of components and parts (including but not limited to engines, transmissions, outdrives, and appliances) for the Motoryacht to the Owner and Owner's sole remedy for defects in components or parts subject to those warranties shall be the assertion of Owner's rights against those manufacturers or distributors.

Bayliner shall have no liability or responsibility for any damage or expense, and no Bayliner warranty is provided for, the following:

A Motoryacht purchased from any party other than an authorized Bayliner dealer; a Motoryacht, including components and systems, that has been altered or modified from factory specifications; equipment and accessories (including engines) not factory installed by Bayliner; a Motoryacht used for commercial purposes; any components or parts (including but not limited to engines, transmissions, outdrives, and appliances) that carry their own warranties; damage or deterioration of cosmetic surface finishes, including cracking, crazing, discoloration, air voids, fading or oxidation of gel coat, wood finishes (varnishes, stains and paints), fabrics, vinyls, plastics, plated or painted metal and stainless steel finishes; anti-fouling bottom paint or zinc anodes; the cost to remove, disassemble or reinstall components not installed by Bayliner that require removal to access parts covered by this warranty; a Motoryacht which has been misused, operated in a negligent manner, used for racing or military purposes; operated without normal maintenance, operated contrary to any instructions furnished by Bayliner or its component suppliers, or operated in violation of applicable law or regulations; any representation or implication relating to speed, range, fuel consumption or estimated performance characteristics; window glass and windshield damage or breakage; damage, shrinkage, or deterioration of carpet, upholstery and exterior canvas tops, enclosures, and weather covers (including rainwater leakage); and any damage, cost, or expense caused by an act of nature.

#### Other Limitations

**IN NO EVENT SHALL BAYLINER OR THE SELLING DEALER BE RESPONSIBLE FOR INDIRECT, INCIDENTAL, OR CONSEQUENTIAL DAMAGES (including but not limited to loss of time, loss of use, inconvenience, travel expense, transportation costs, towing, damage or loss of use of other property or equipment, loss of profits, and loss of contracts), WHETHER SUCH CLAIM OR ACTION IS BASED ON CONTRACT, WARRANTY, NEGLIGENCE, STRICT LIABILITY OR ANY OTHER TORT.** Some states do not allow the exclusion of incidental or consequential damages, so the above limitation or exclusion may not apply to you.

This warranty gives the Owner specific legal rights, and the Owner may also have other rights which vary from state to state. This document contains the entire warranty given by Bayliner and there are no terms, promises, conditions or warranties, express or implied, other than those contained herein. **ALL OTHER WARRANTIES, EXPRESS OR IMPLIED, INCLUDING IMPLIED WARRANTIES OF FITNESS AND MERCHANTABILITY ARE EXPRESSLY EXCLUDED. TO THE EXTENT ALLOWED BY LAW, ANY IMPLIED WARRANTY OF MERCHANTABILITY IS LIMITED TO THE DURATION OF THIS WRITTEN WARRANTY.** Some states do not allow limitations on how long an implied warranty lasts, so the above limitations may not apply to you. Bayliner specifically does not authorize any person to extend the time or scope of this warranty or to create or assume for Bayliner any other obligation or liability with respect to Bayliner Motoryacht.

#### Transferability

The unexpired portion of this warranty may be transferred to a second owner upon purchase of the Motoryacht from an authorized Bayliner dealer. A non-refundable recording fee of \$250.00 must accompany any transfer request. Bayliner reserves the right to reject a warranty transfer request for a Motoryacht that has been damaged, neglected, or otherwise previously excluded from warranty. Bayliner will confirm all warranty transfers in writing to the dealer and the second owner.

For further information regarding this limited warranty, please contact Bayliner at:

Bayliner Marine Corporation  
P.O. Box 9029  
Everett, WA 98206  
Phone (360) 435-5571







**Part Number 118000**

**Bayliner • P.O. Box 9029 • Everett, WA 98206 • 360-435-5571**