

Franz®

4085 EU

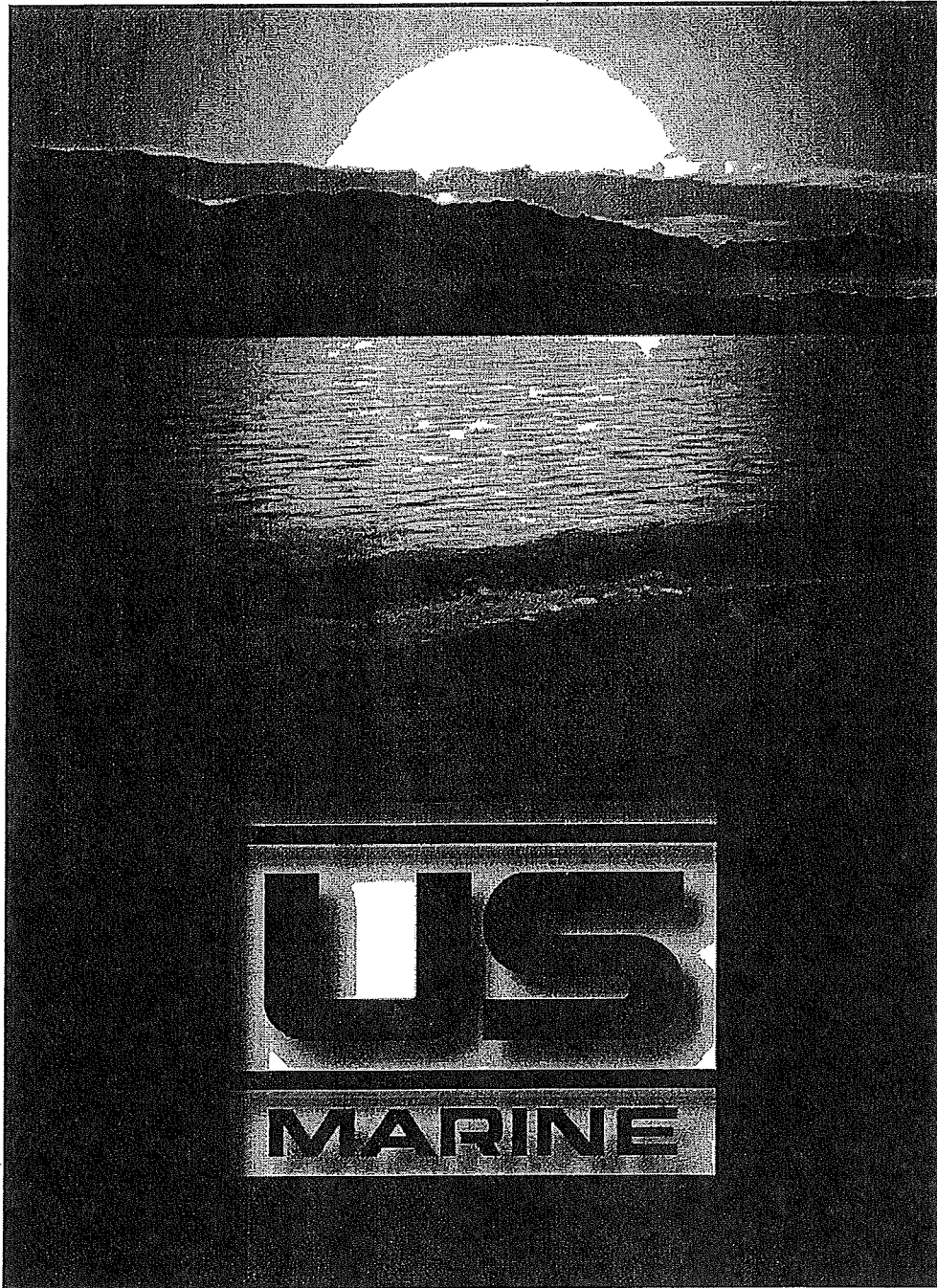

Routing Supplement

Port Engine Serial Number: _____

Stbd. Engine Serial Number: _____

Hull Identification Number: _____

The Hull Identification Number (HIN) is located on the starboard side of the transom. Be sure to record the HIN (and the engine serial numbers) in the space provided above. Please refer to the HIN for any correspondence or orders.

© 1999 Avanti Technical Publications. All rights reserved.

No part of this publication may be reproduced, stored in any retrieval system, or transmitted in any form by any means, electronic, mechanical, photocopying, recording or otherwise, without prior written permission of Avanti.
Printed in the United States of America.

General Notes

The material in this document is for information only and is subject to change without notice. While reasonable efforts have been made in the preparation of this document to assure its accuracy, Avanti assumes no liability resulting from errors or omissions in this document, or from the use of information contained herein.

Due to our commitment to product improvement, Avanti reserves the right to make changes in the product design, specifications, and equipment at any time without notice or obligation. Illustrations and/or photos may show optional equipment.

All Avanti products meet or exceed USCG (United States Coast Guard) and/or NMMA (National Marine Manufacturer's Association) construction standards. Manufactured with 1,1,1 Trichloroethane, a substance which harms public health and environment during the manufacturing process by destroying ozone in the upper atmosphere.

Proprietary Rights

This document discloses subject matter in which Avanti has proprietary rights. The information and design disclosed herein were originated by and are the property of Avanti. Neither receipt nor possession thereof confers or transfers any right to reproduce, copy, alter or disclose the document or any part thereof, any information contained therein, or to construct boats or any item from it, except by written permission from or written agreement with Avanti. This document is to be returned upon request to Avanti.

CONTENTS

1 CHAPTER 1: HULLSIDE HARDWARE AND DRAINS

1 Starboard Hullside

2 CHAPTER 2: DECK HARDWARE

2 Bow

3 Aft Deck

3 Top Deck

4 CHAPTER 3: DRAINS

4 Shower Drain

4 Sink Drains

5 Cockpit

6 Swim Step

7 CHAPTER 4: SYSTEM ROUTINGS

7 Bilge Pump Systems

8 Engine Cooling Systems

9 Engine Exhaust System

10 Fuel System Routing

11 Fuel System Components (Diesel Option)

11 Fuel Fill & Vent Routing

12 Heat Exchange System (Diesel Option)

12 Blower System

13 Gas Generator (Option)

13 Diesel Generator (Option)

14 Steering System

14 Freshwater Tank Fill & Vent Routing

15 Freshwater System Routing

16 Marine Head System Routing

17 Air Conditioning (Option)

18 CHAPTER 5: ELECTRICAL

18 Deck Electrical Routings

18 Dash Layout

19 CHAPTER 6: LIFTING SLING POSITIONS

20 CHAPTER 7: ISO SYMBOLS

22 LIMITED WARRANTY

CHAPTER 1: HULLSIDE HARDWARE AND DRAINS

Starboard Hullside

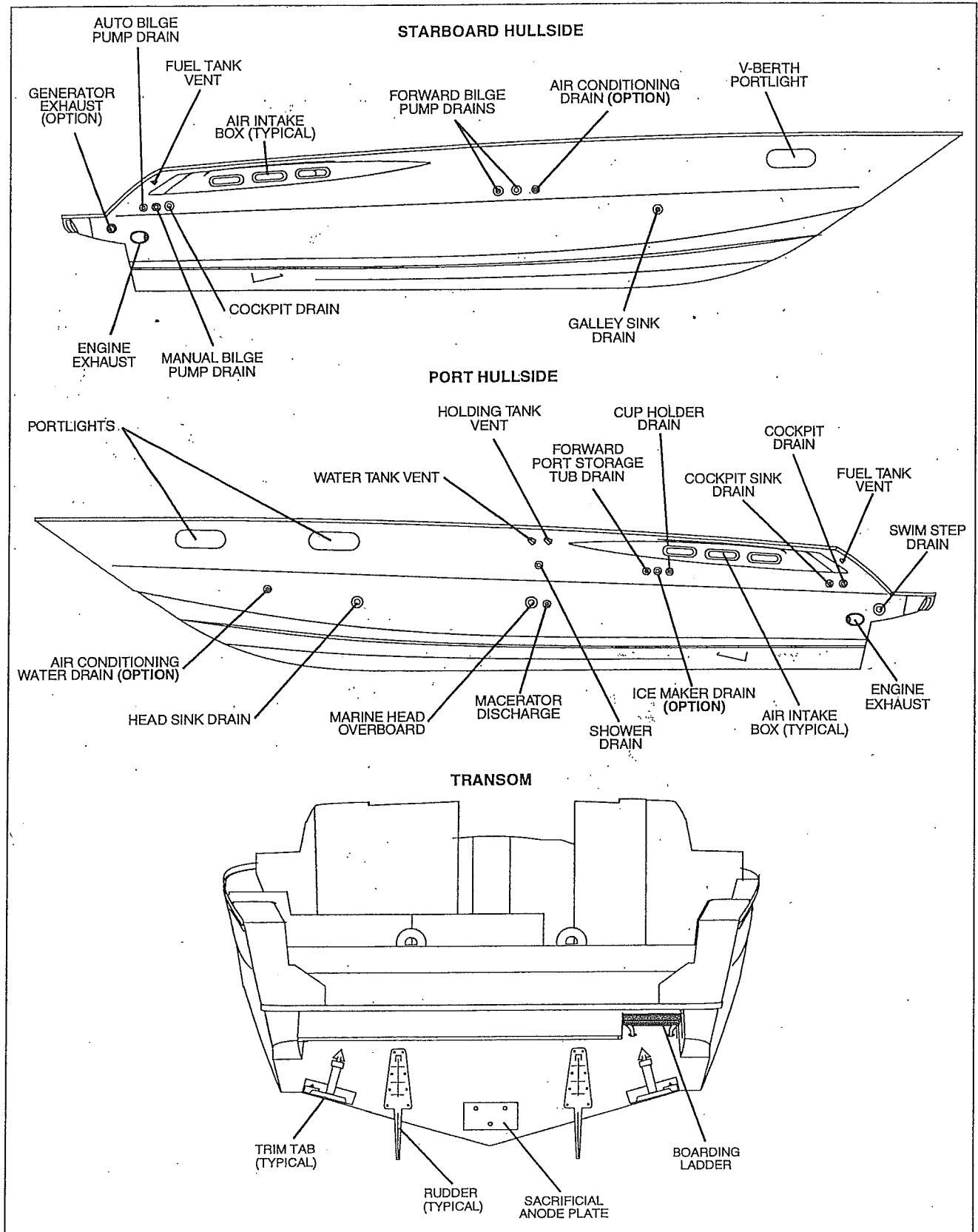

CHAPTER 2: DECK HARDWARE

Bow

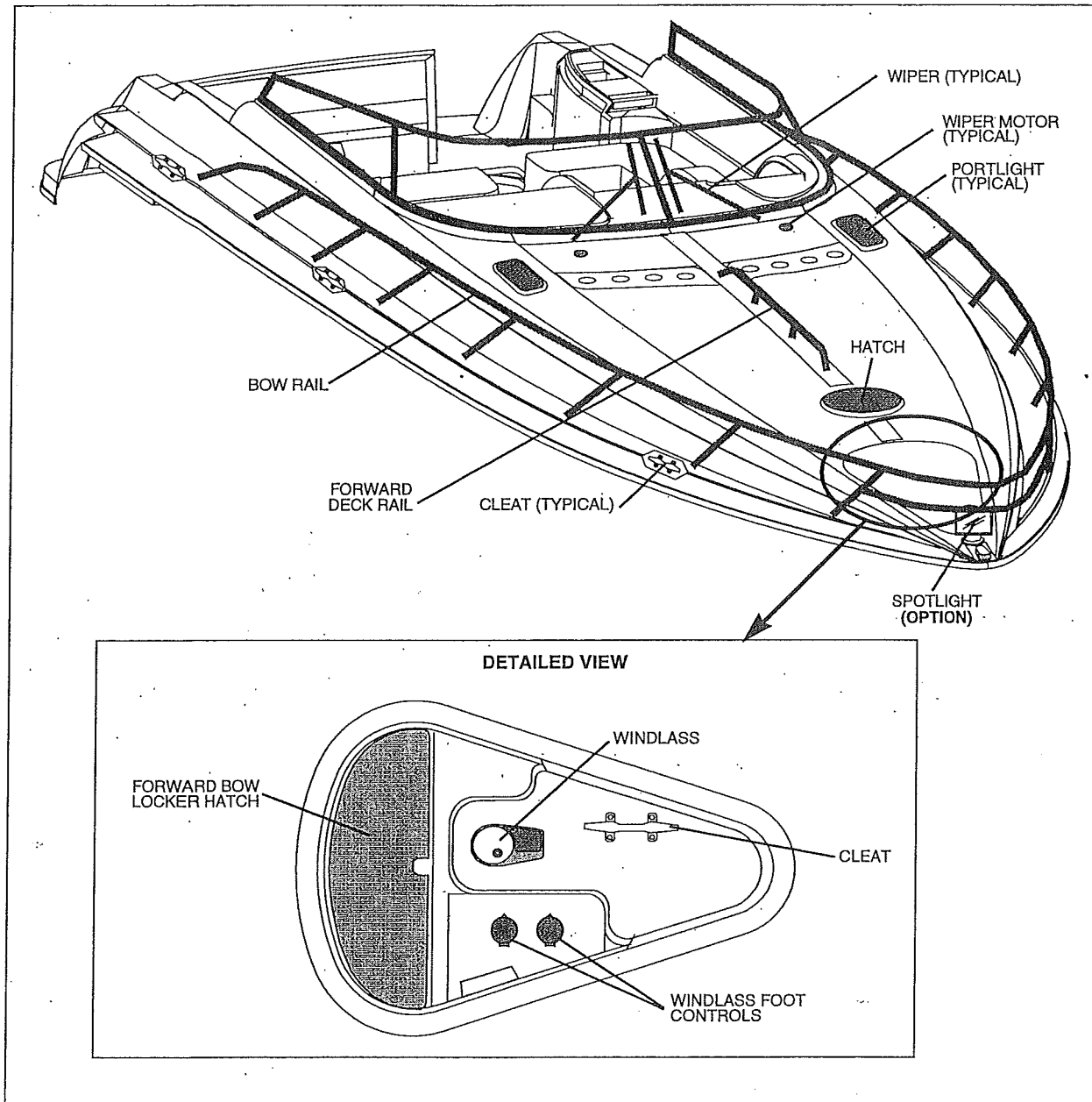



Aft Deck

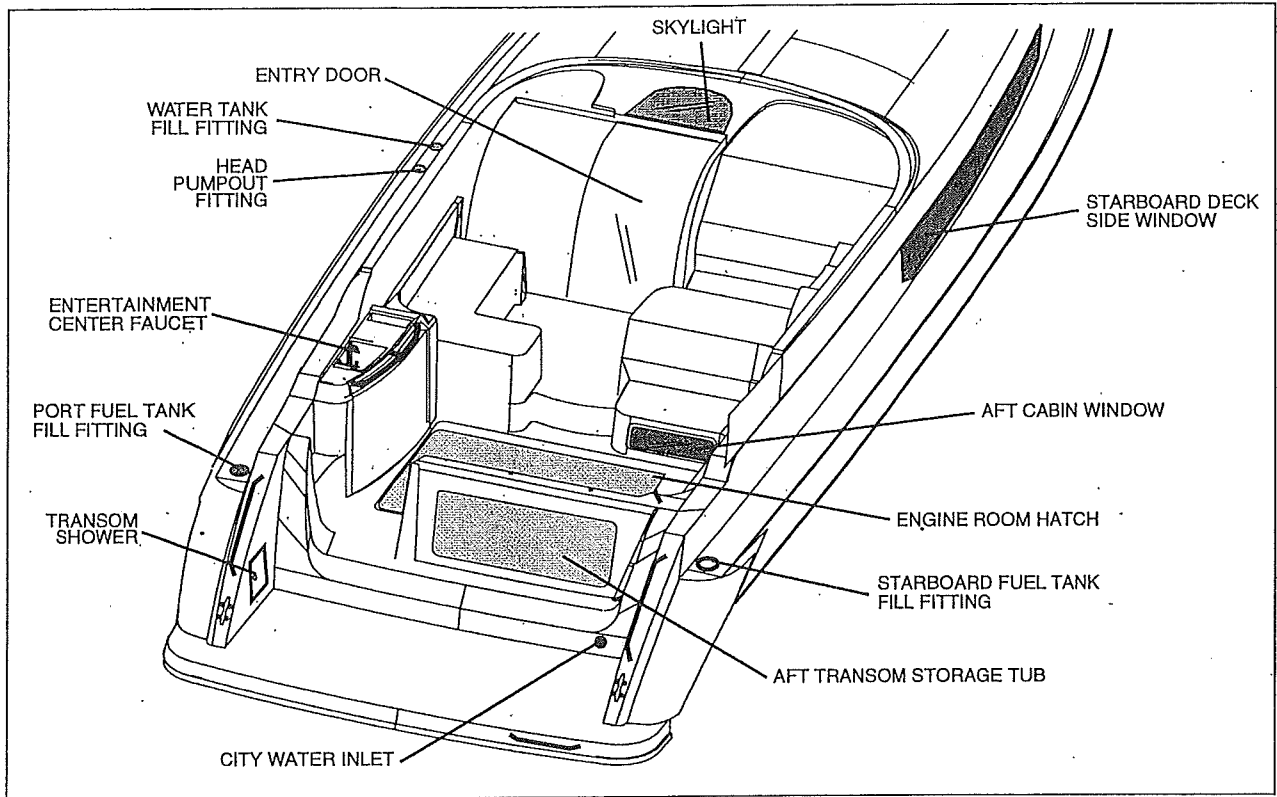

Top Deck

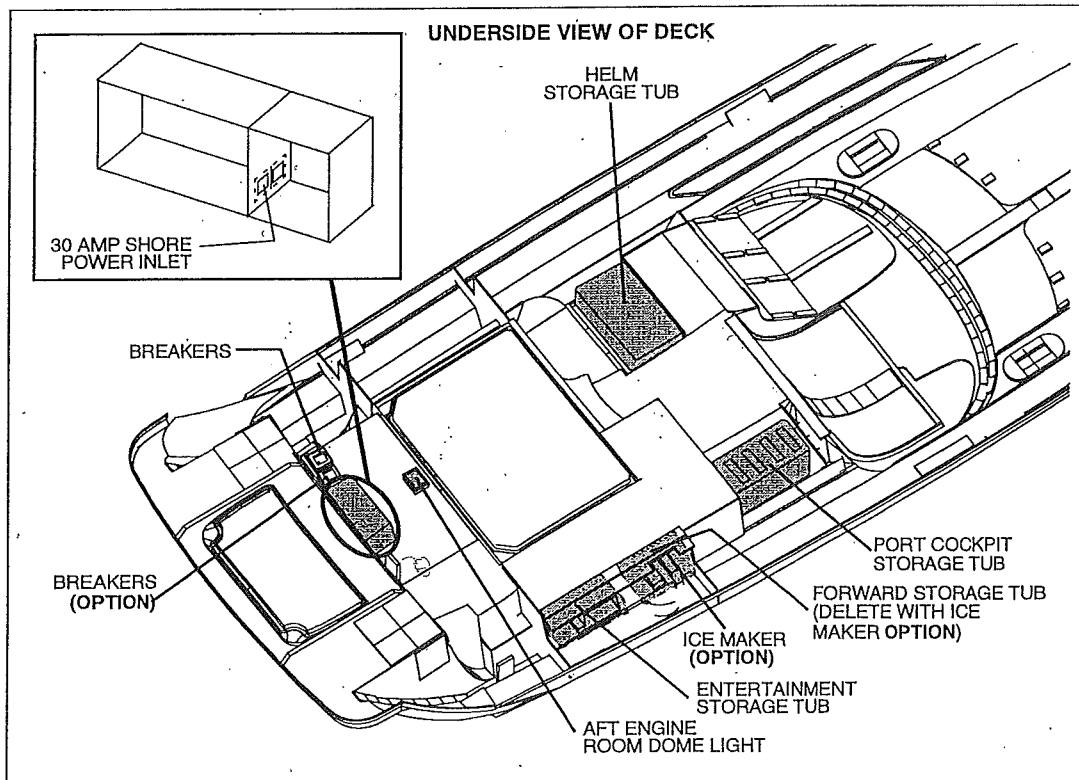

CHAPTER 3: DRAINS

Shower Drain

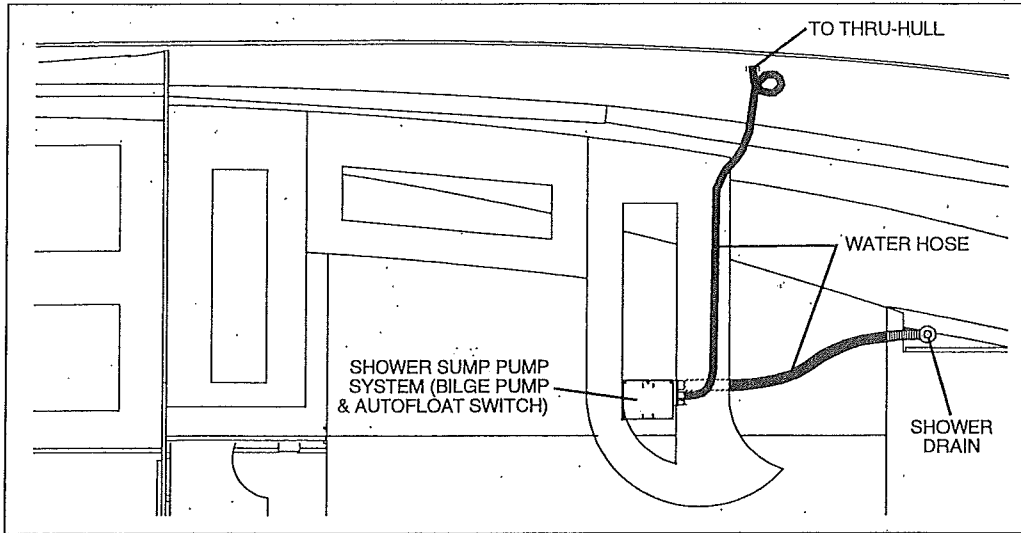

Sink Drains

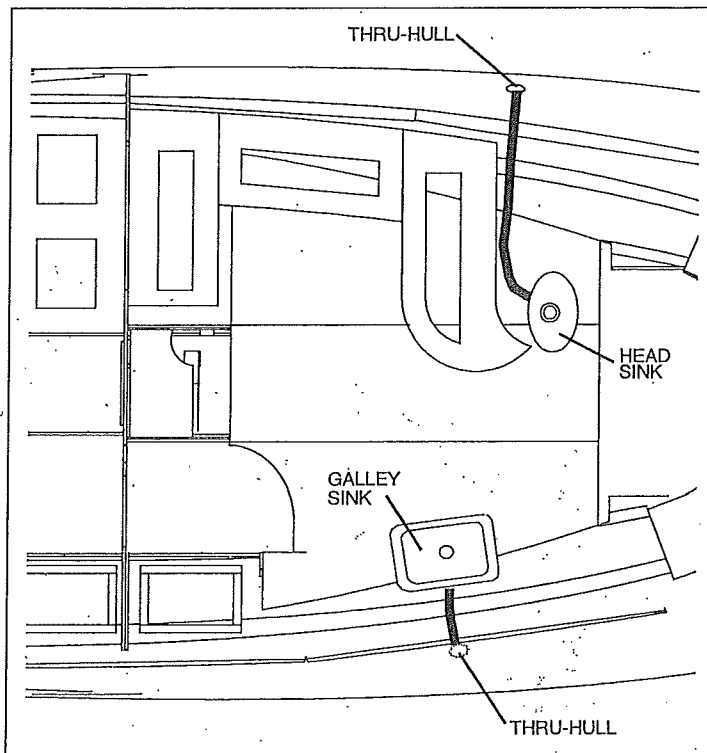



Cockpit

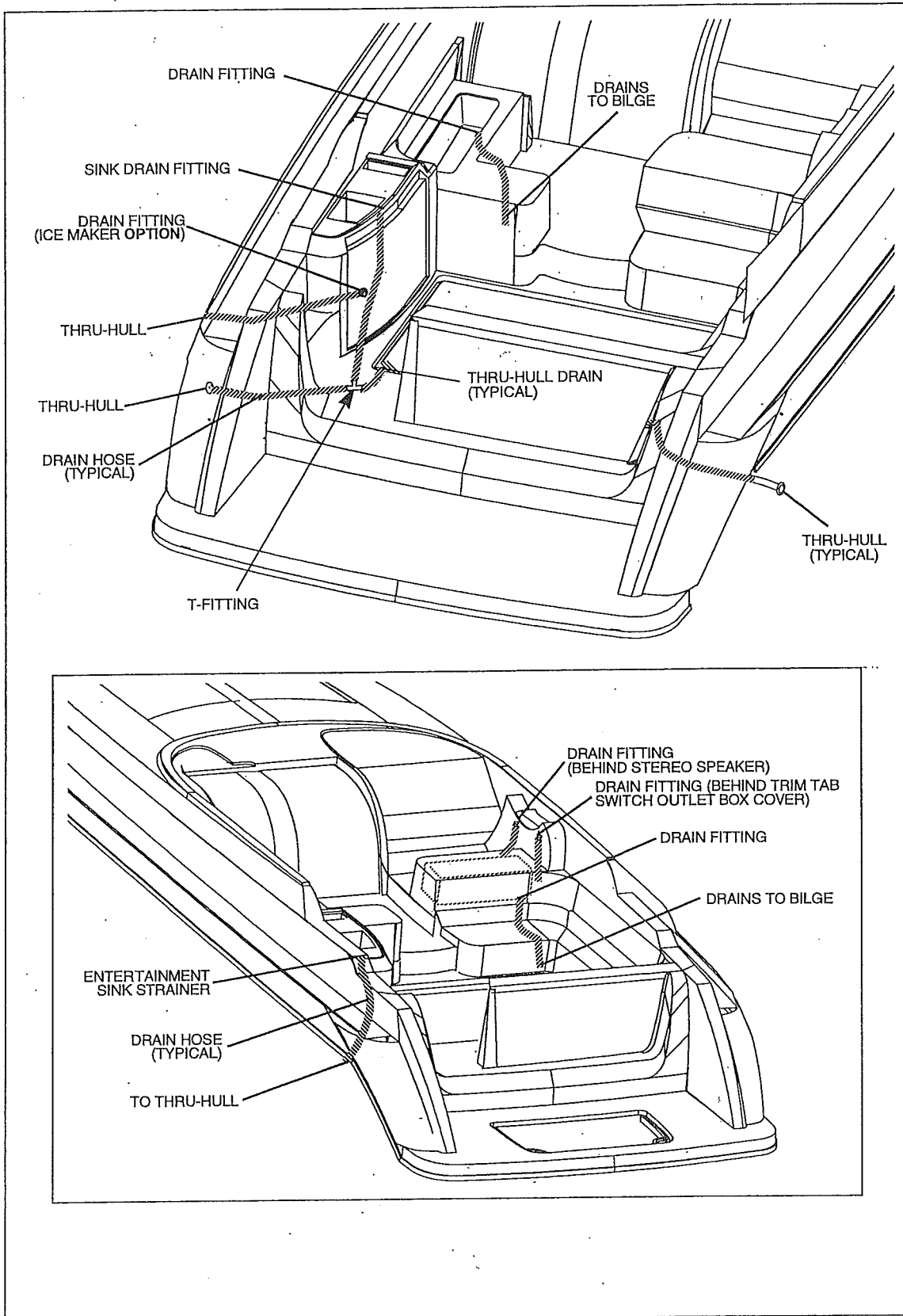



Swim Step

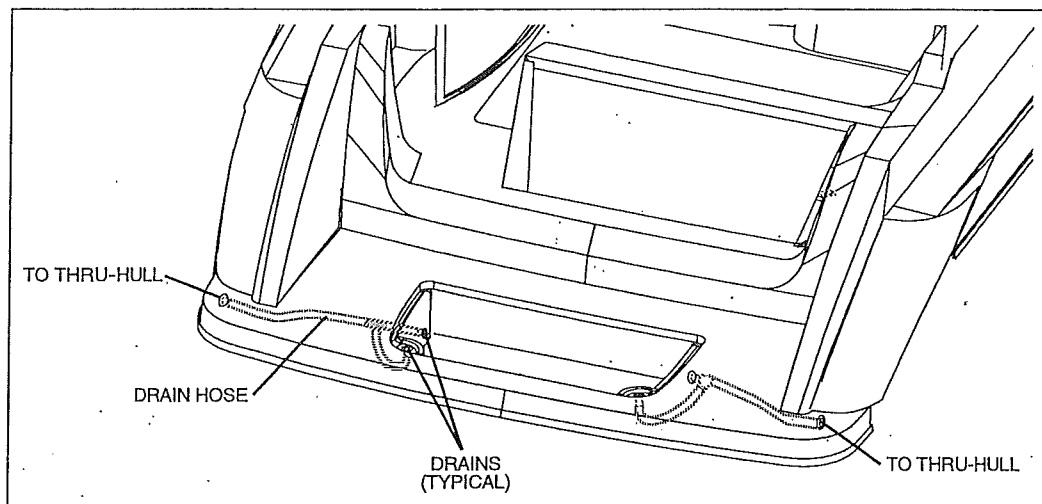

CHAPTER 4: SYSTEM ROUTINGS

Bilge Pump Systems

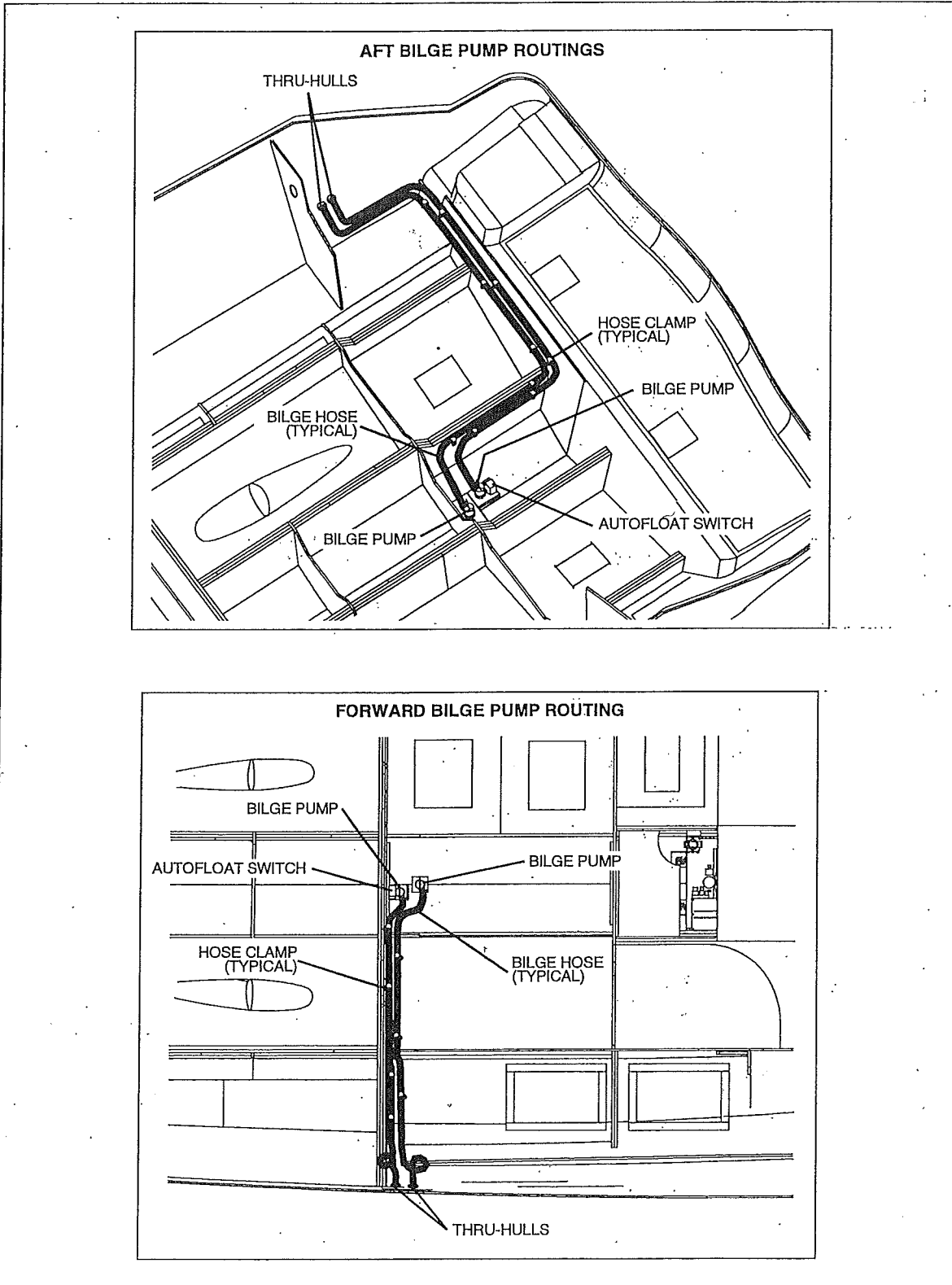



Engine Cooling Systems

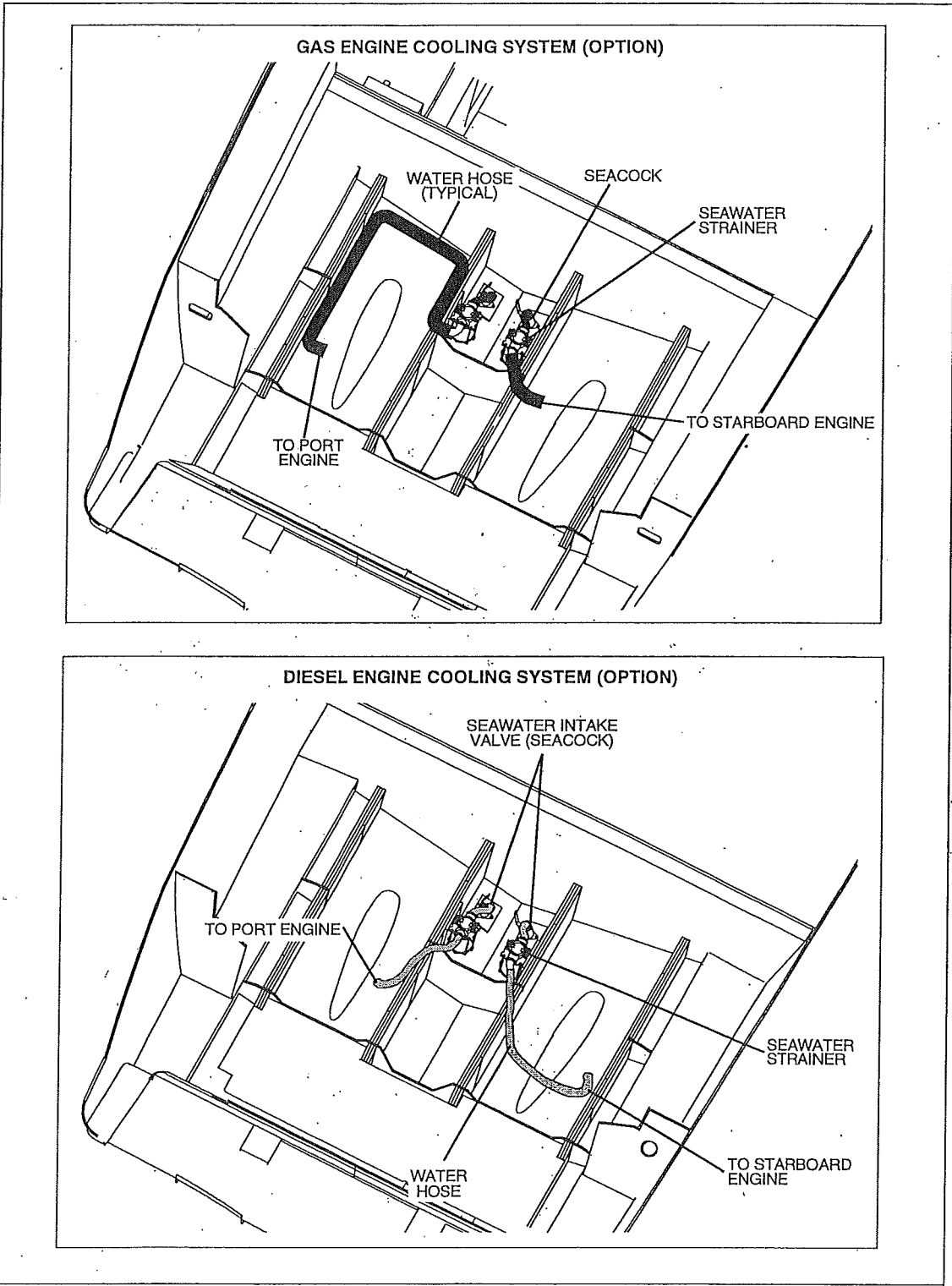

Engine Exhaust System

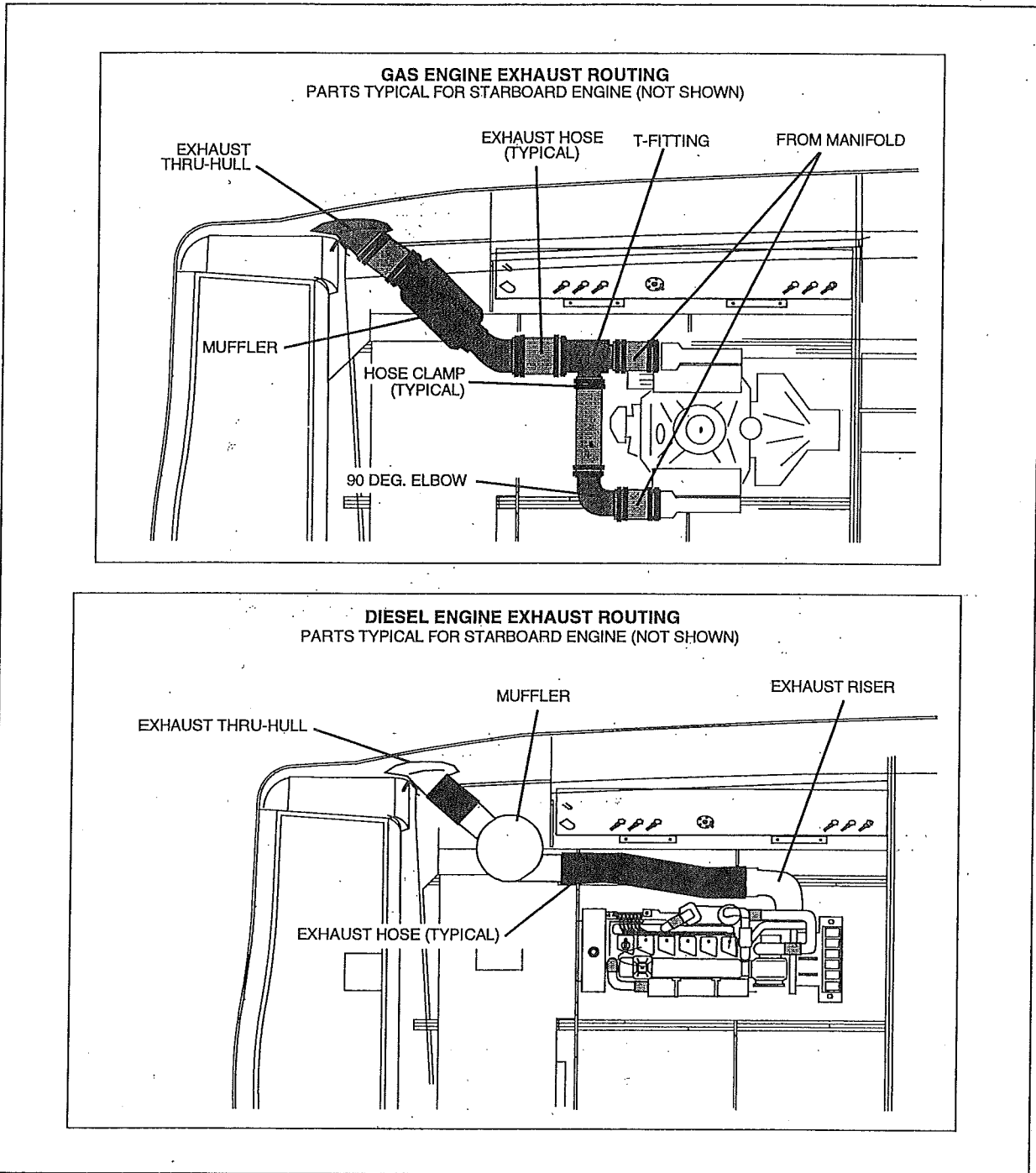



Fuel System Routing

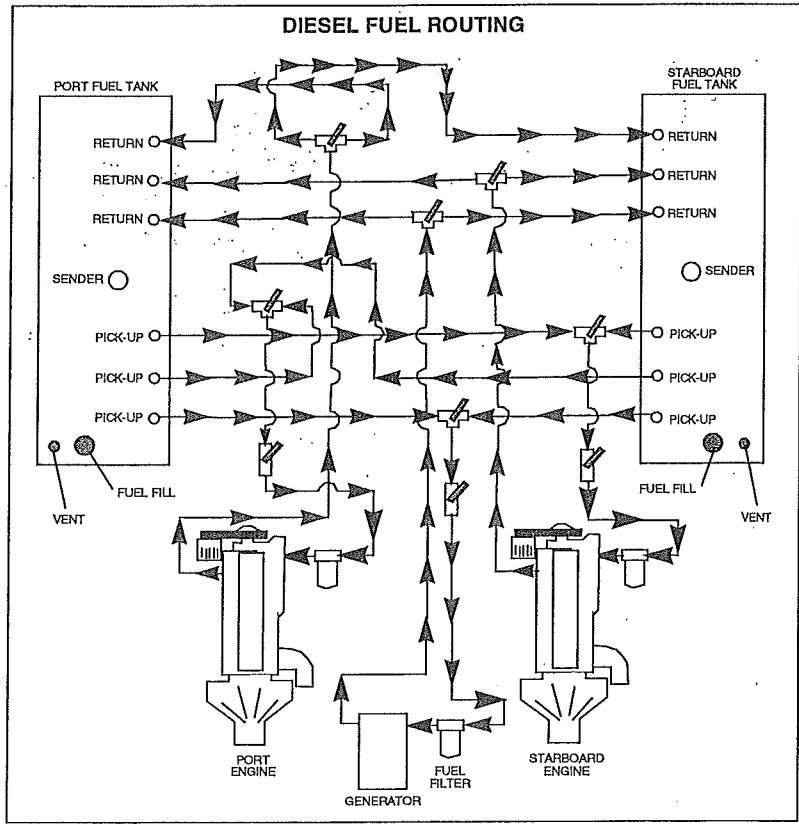
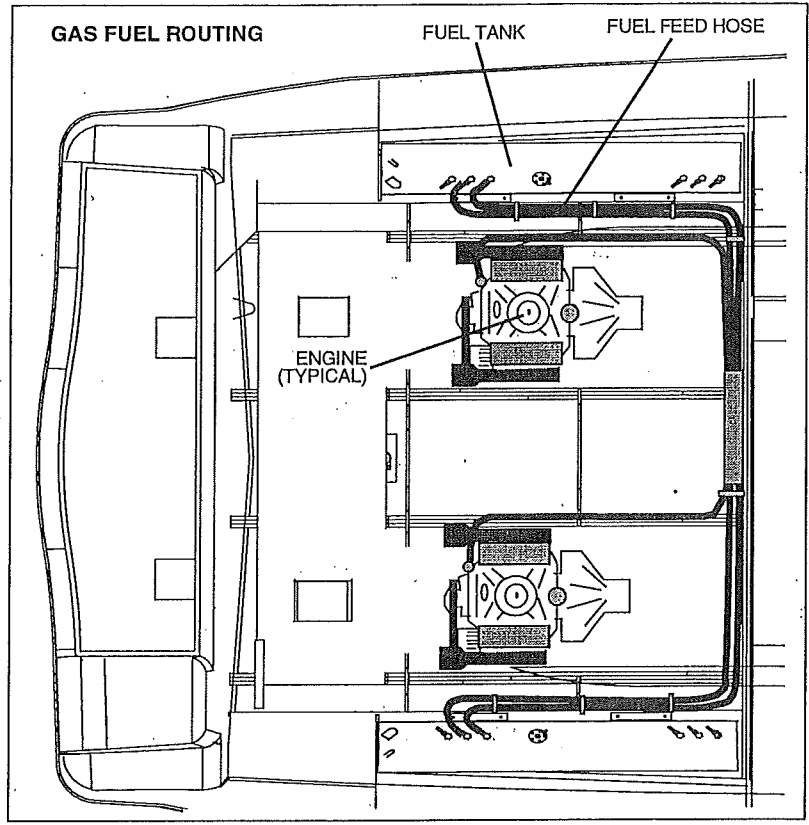

Fuel System Components (Diesel Option)

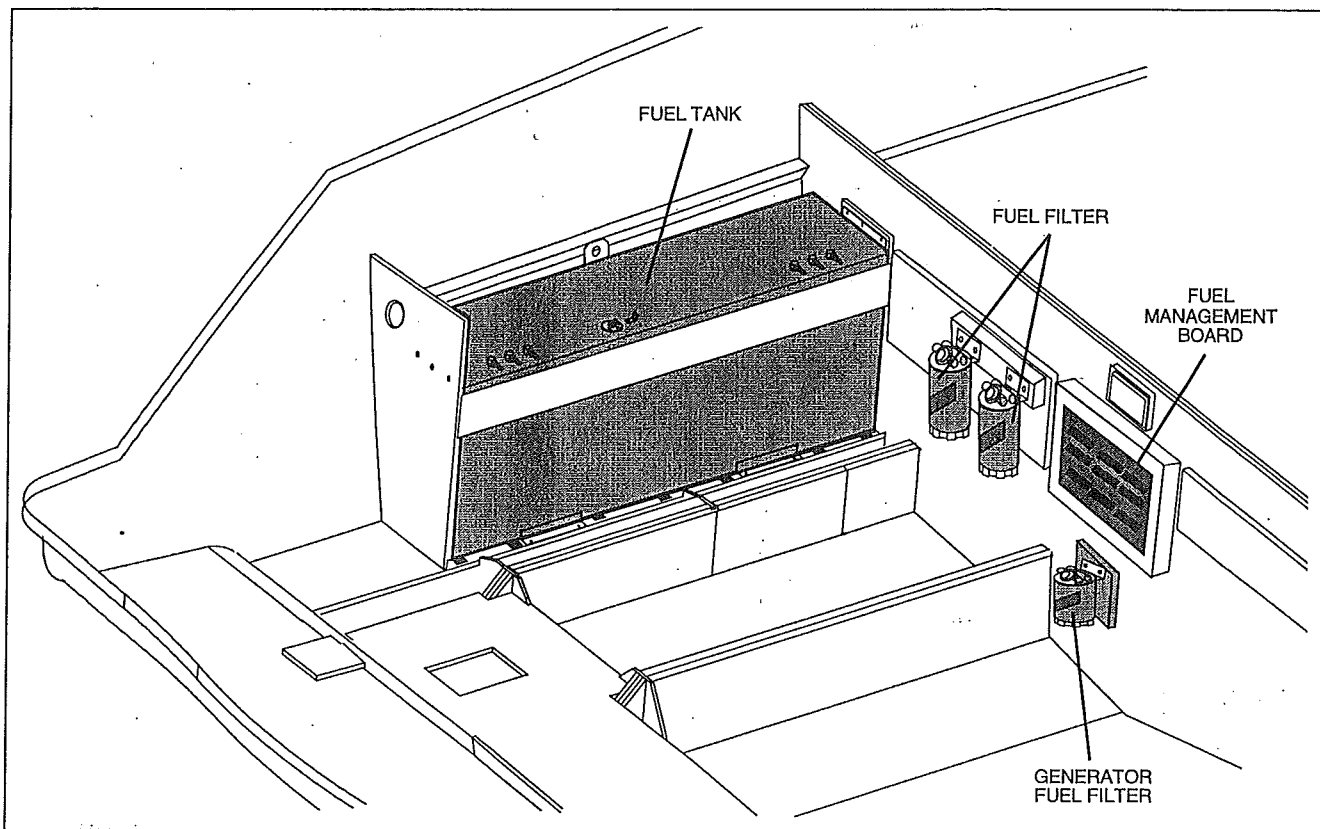

Fuel Fill & Vent Routing

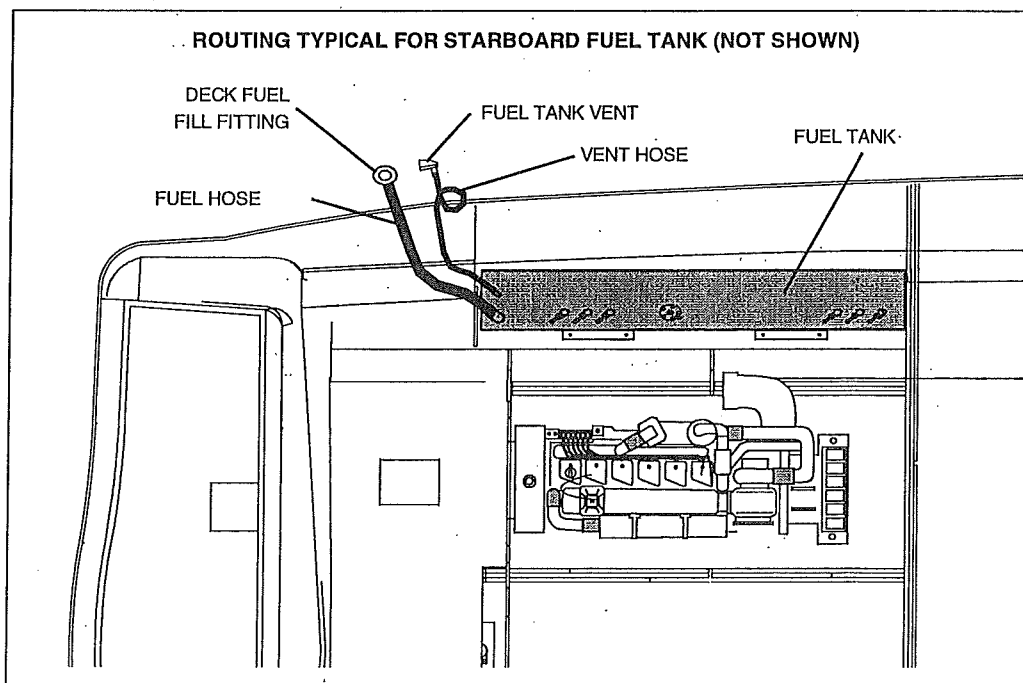



Heat Exchange System (Diesel Option)

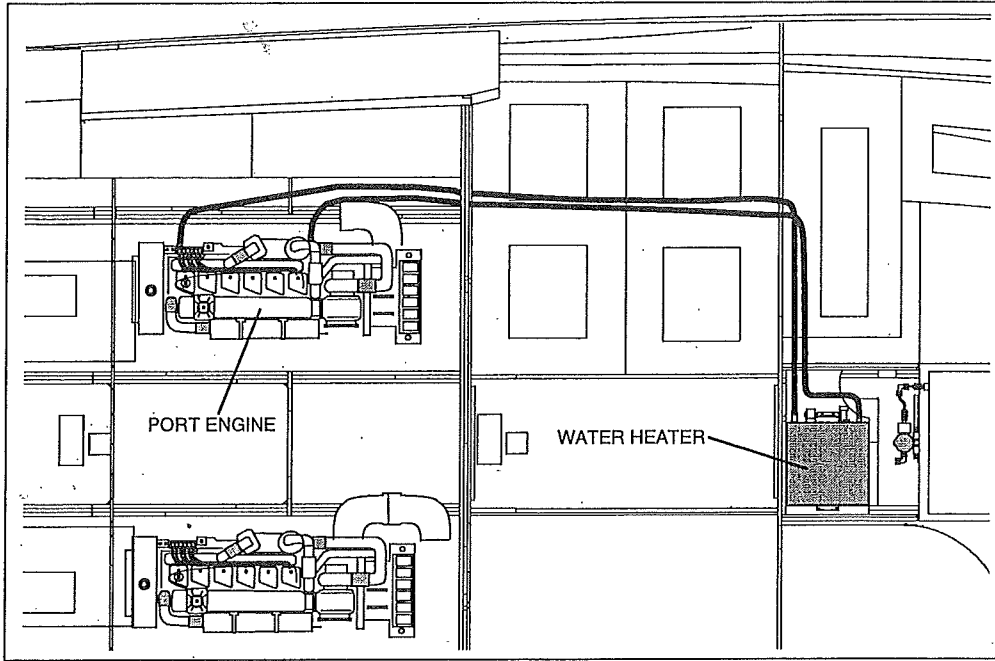

Blower System

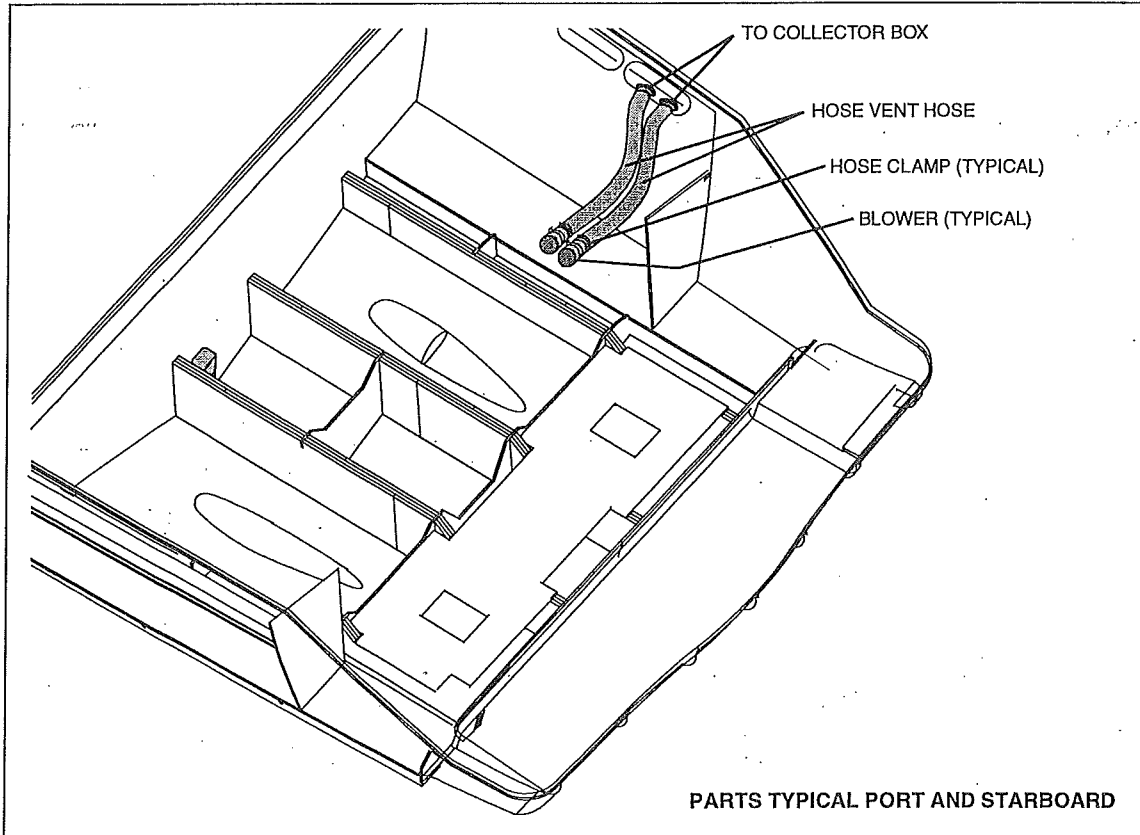

Gas Generator (Option)

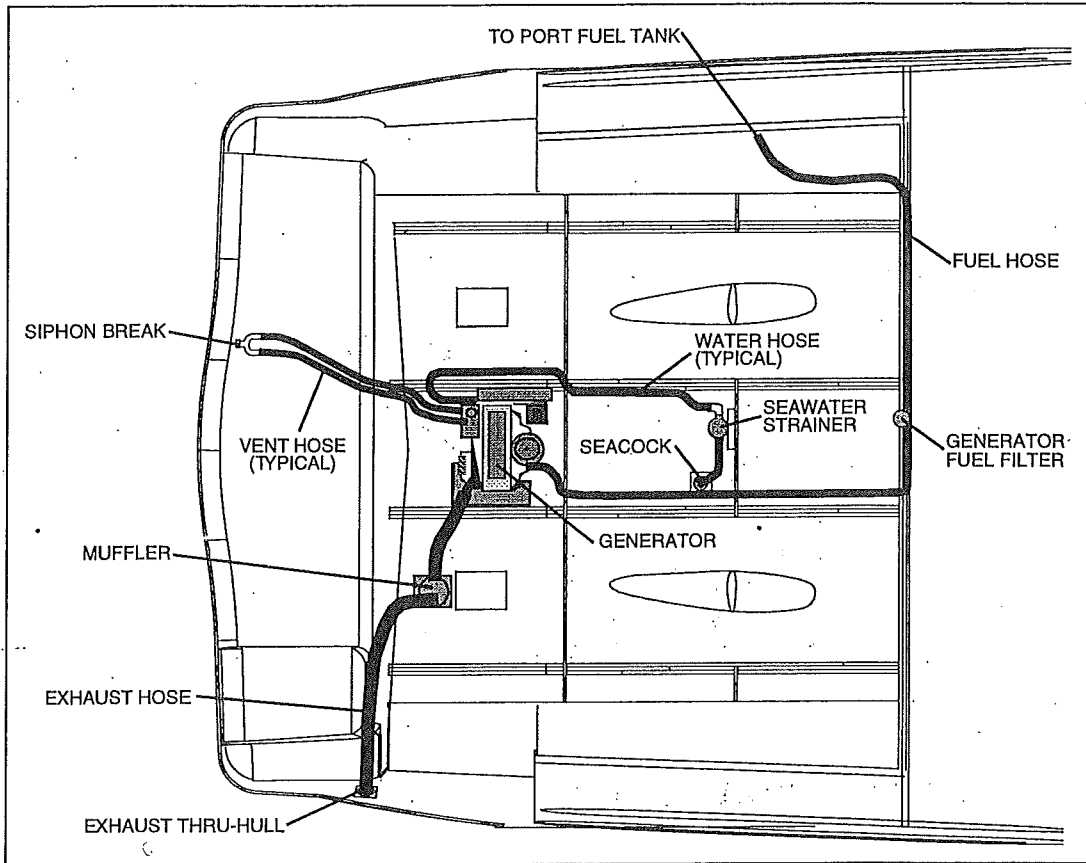

Diesel Generator (Option)

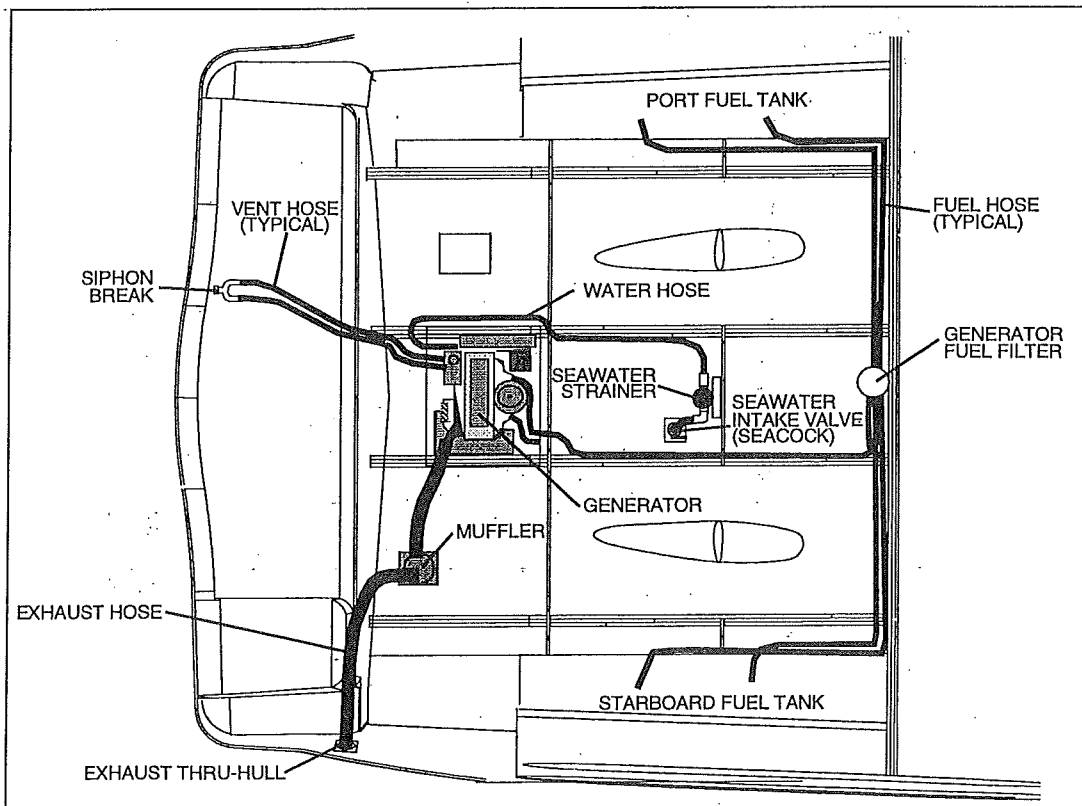



Steering System

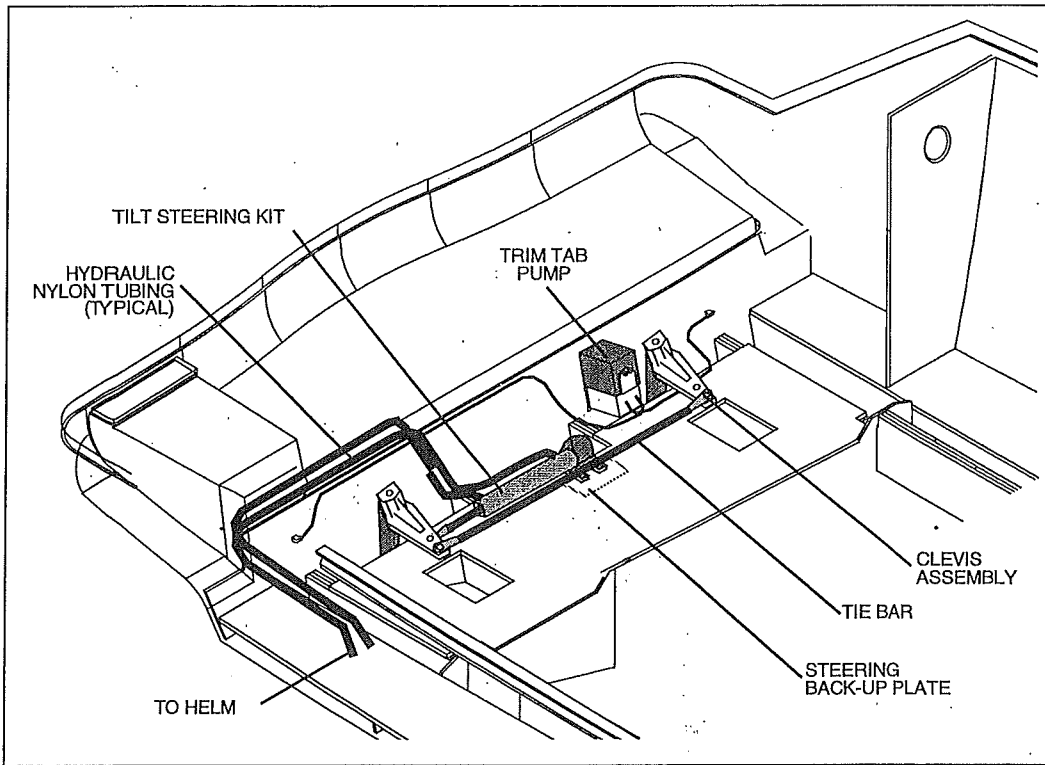

Freshwater Tank Fill & Vent Routing

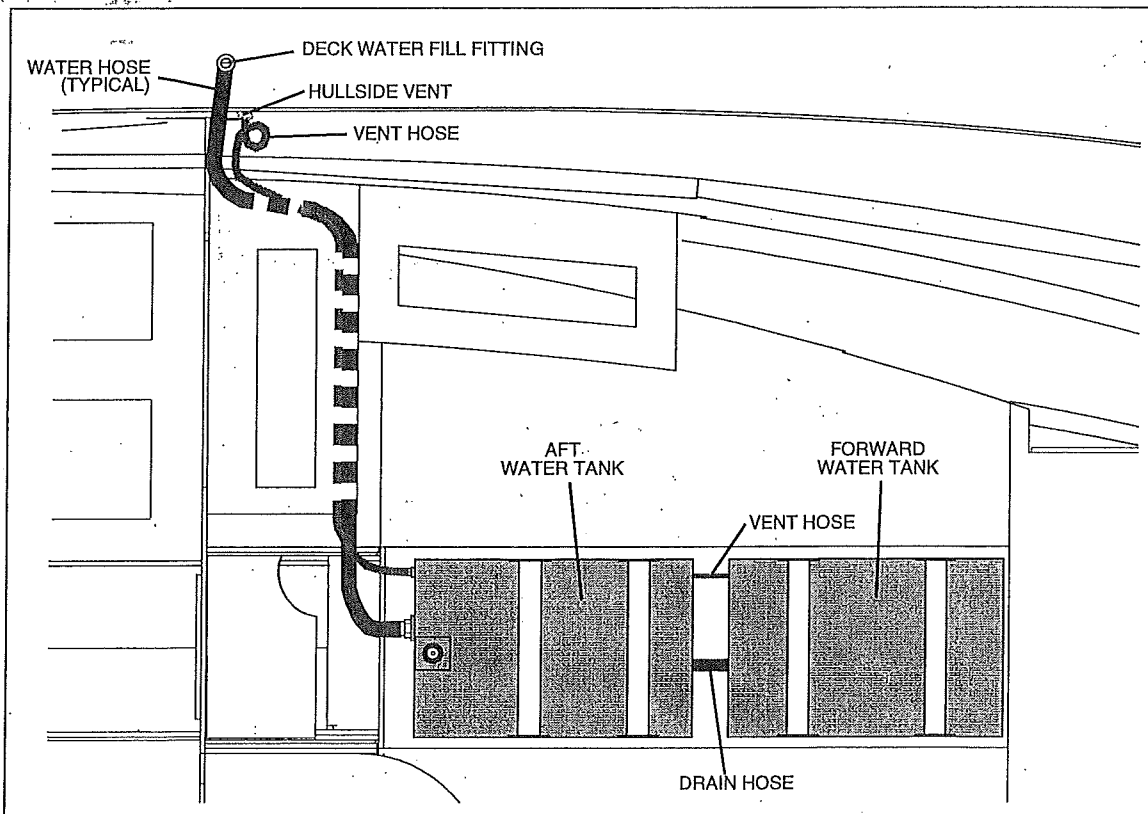

Freshwater System Routing

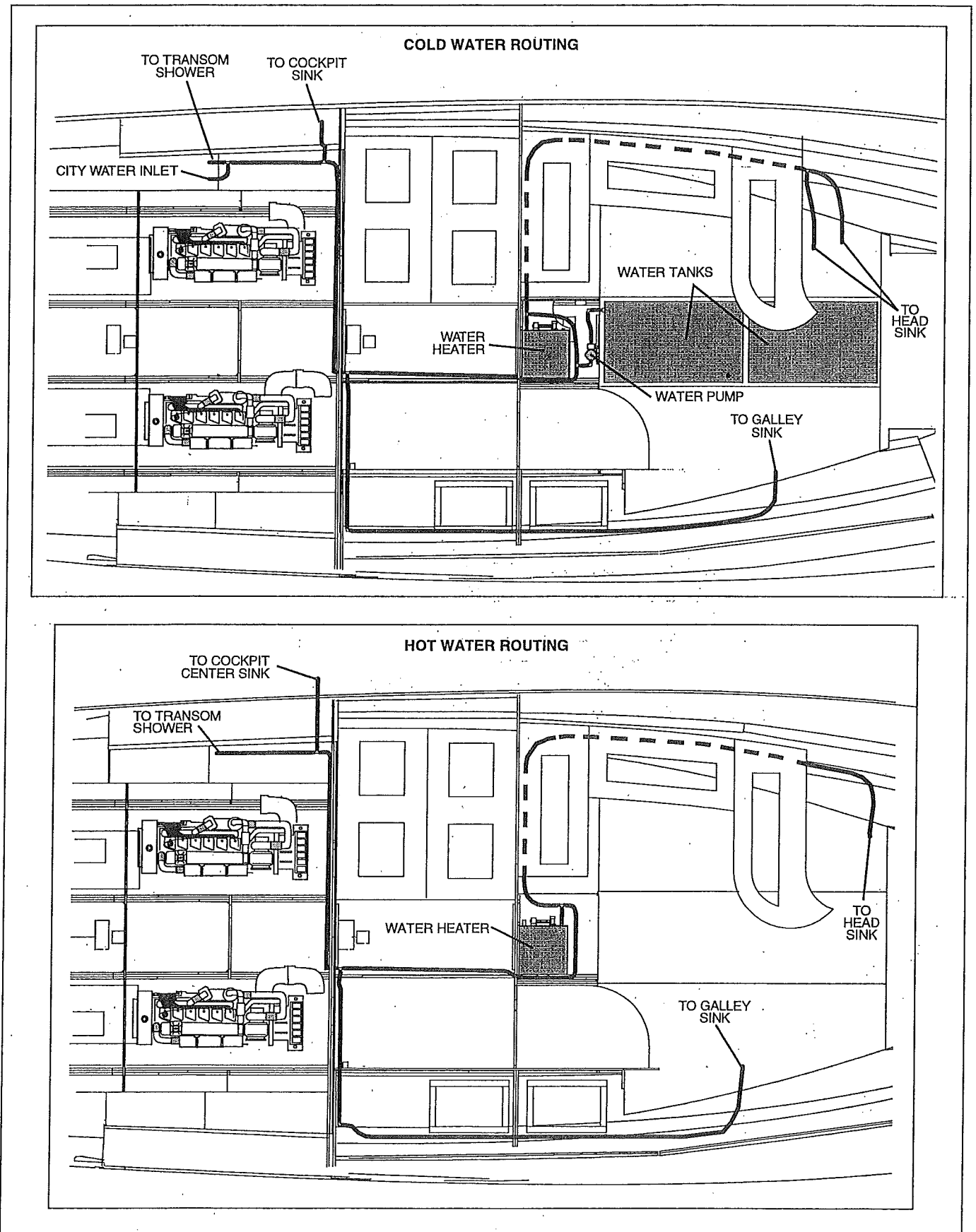



Marine Head System Routing

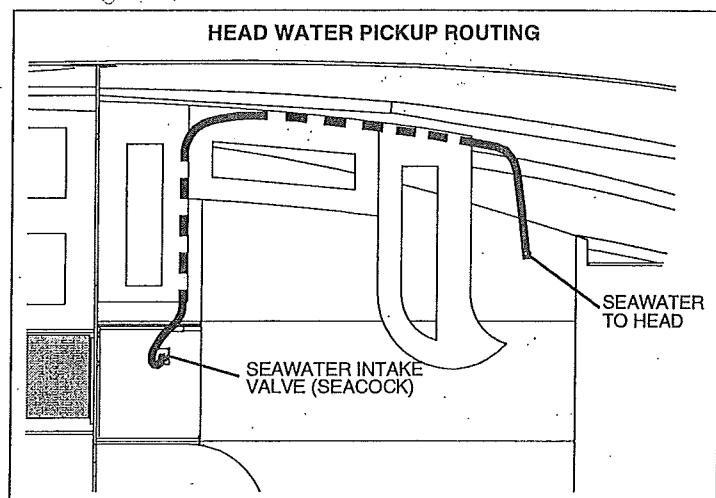
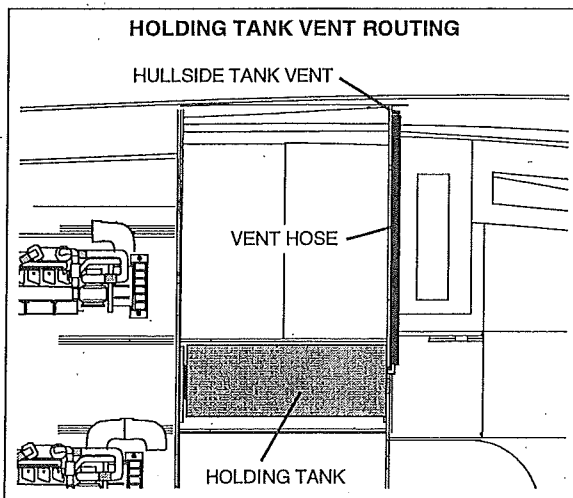
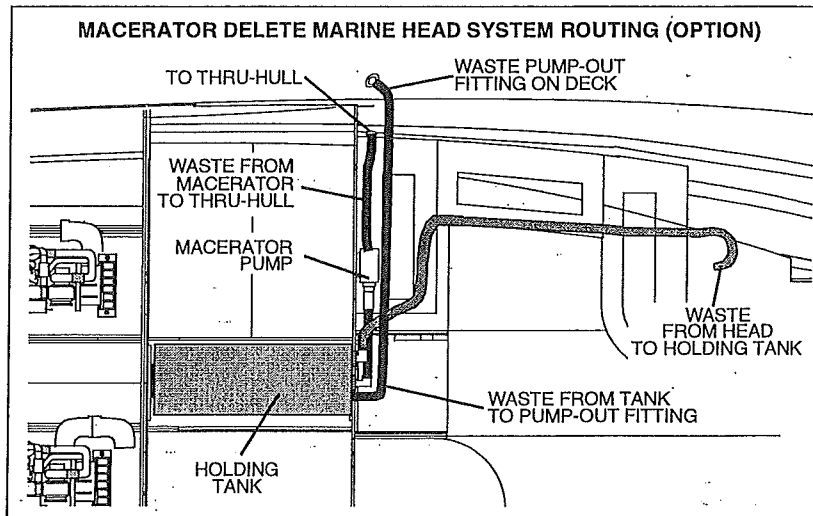
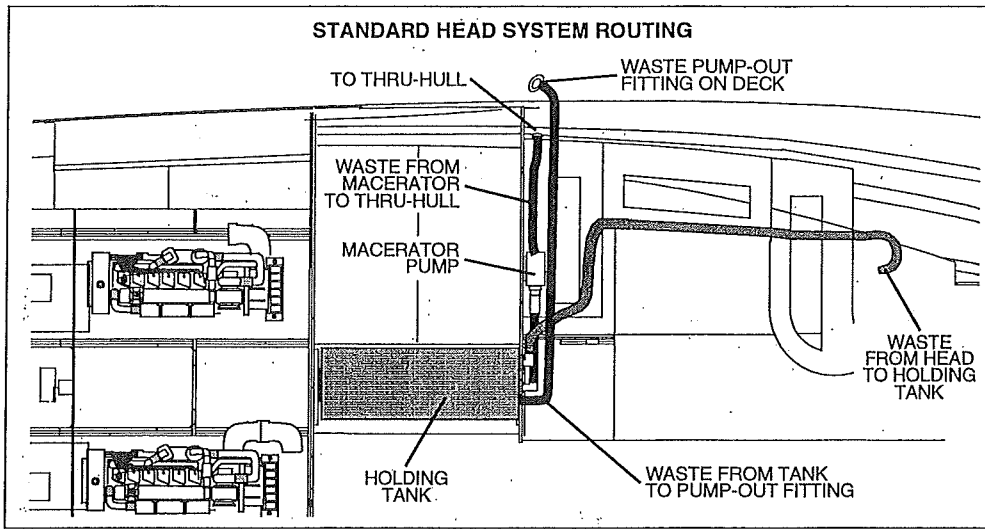

Air Conditioning (Option)

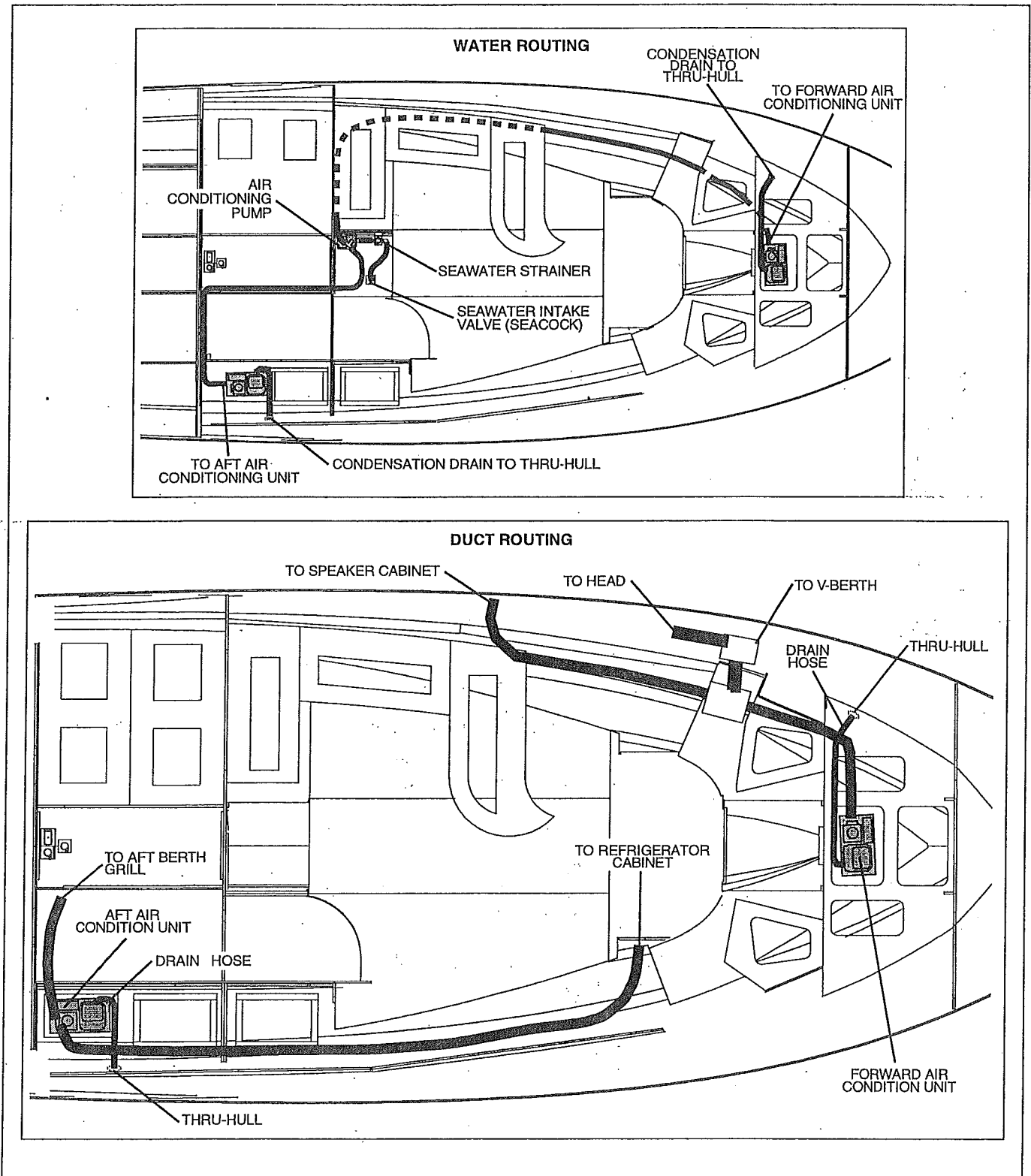



CHAPTER 5: ELECTRICAL

Deck Electrical Routings

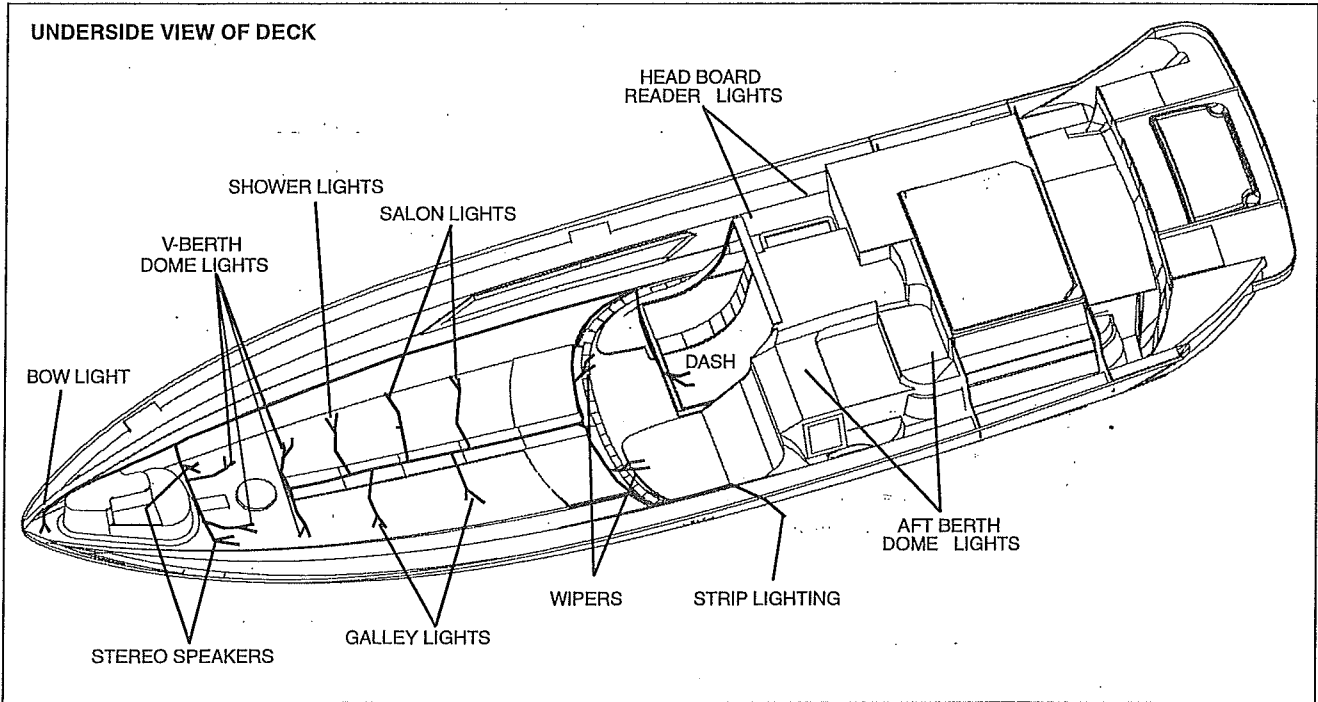

Dash Layout

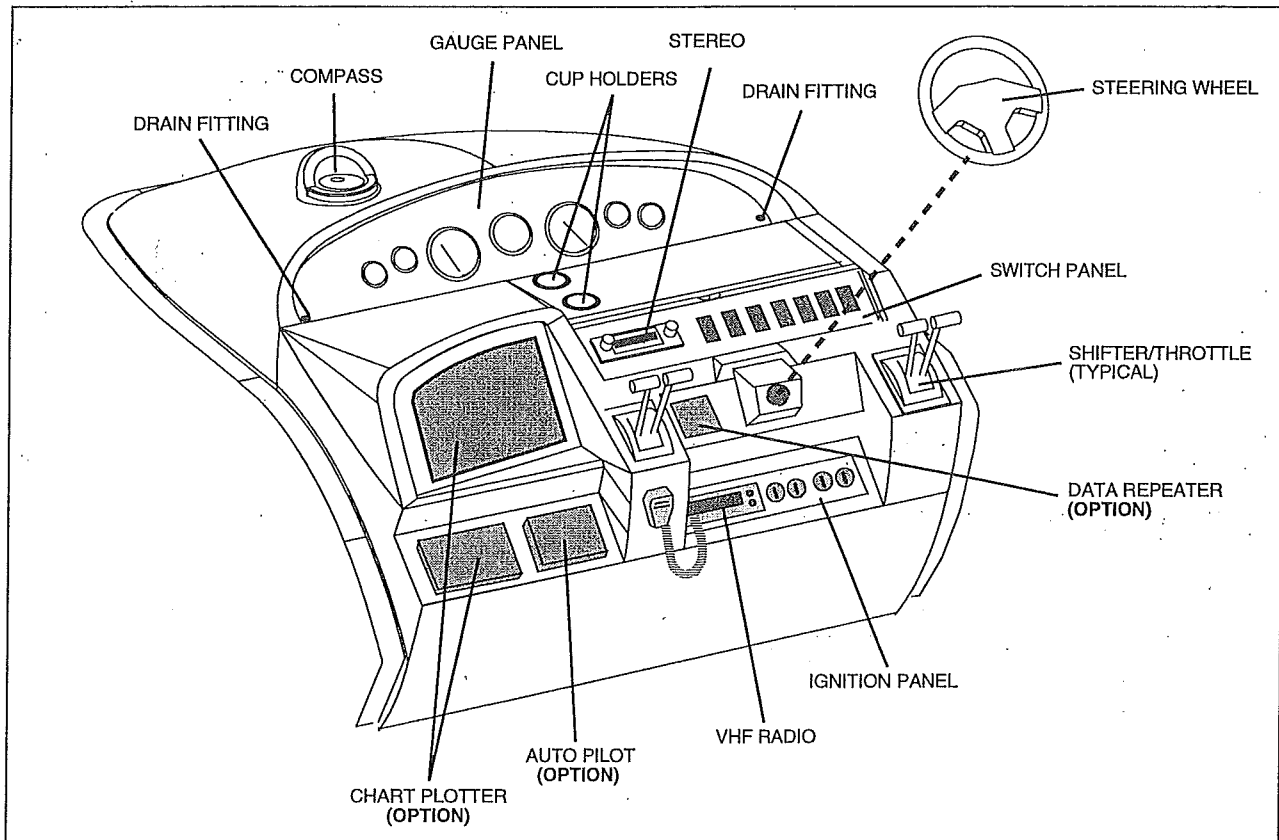

CHAPTER 6: LIFTING SLING POSITIONS

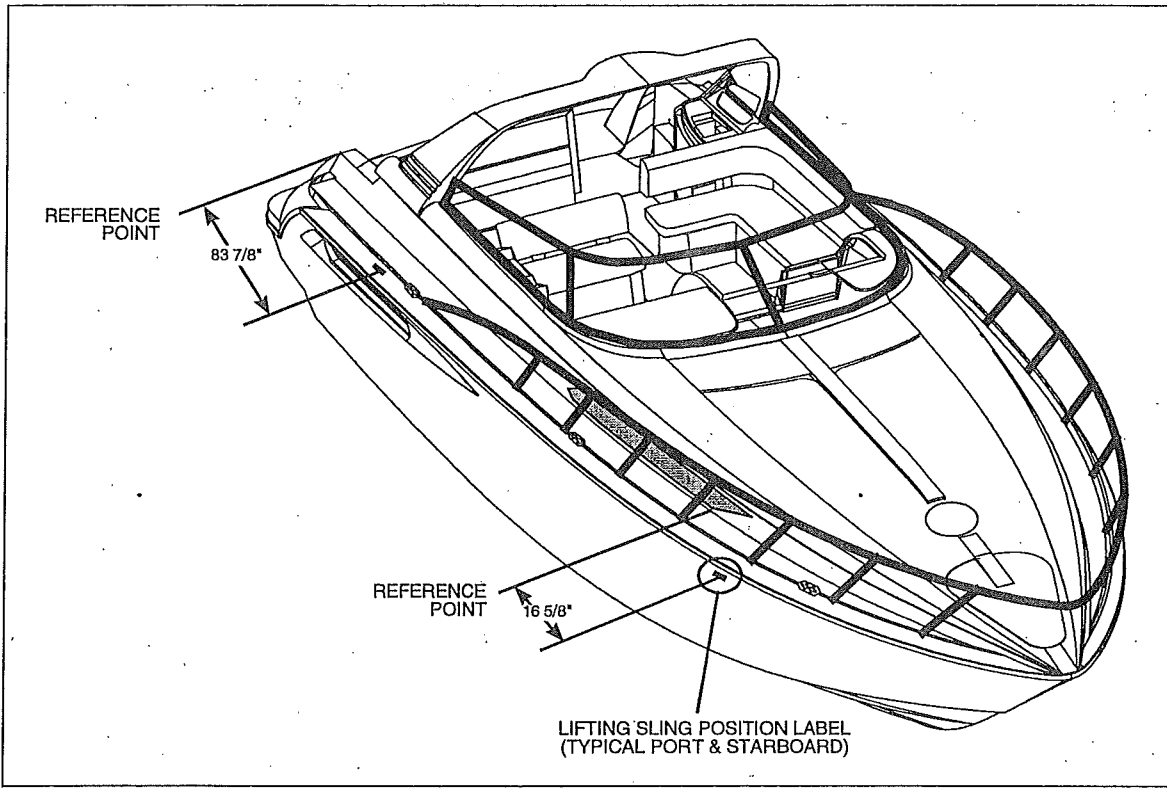

CHAPTER 7: ISO SYMBOLS

These ISO symbols may be used throughout your boat to identify and describe various systems and components.

Symbol	Description	Symbol	Description	Symbol	Description
	Air Cooled Charge Air Cooler		Air, General		Air, Intake (For Combustion)
	Anchor		Blower		Compass
	Counterclockwise Rotation		Crankshaft Power		Disengage
	Elapsed Time		Electric Generator		Electrical Preheat for Diesel Engine
	Engage		Engine		Engine Air Intake
	Engine Coolant		Engine Exhaust Gas		Engine Exhaust Gas Pressure
	Engine Exhaust Gas Temperature		Engine Inlet Air Filter		Engine Inlet Air Pressure
	Engine Inlet Air Temperature		Engine Oil		Engine Oil Filter
	Engine Oil Level		Engine Oil Pressure		Engine Oil Temperature
	Engine Rotation Speed, R/MIN		Engine Start		Engine Water Jacket Drain
	Exhaust Gas		Filter		Freshwater
	Freshwater Cooled Charged Air		Freshwater Tank		Fuel, Diesel
	Fuel Filter		Fuel General		Fuel Level
	Fuel, Liquid Propane Gas		Fuel Shut Off		Fuel Tank, Diesel
	Fuel Tank, Liquid Propane Gas		Fuel Tank, Unleaded		Fuel, Unleaded
	Heat Exchanger		Holding Tank		Horn

Symbol	Description	Symbol	Description	Symbol	Description
	Hydraulic Oil		Hydraulic Oil Filter		Hydraulic Oil Level
	Hydraulic Oil Pressure		Hydraulic Oil Temperature		Hydraulic System
	Hydraulic System Malfunction		Interior Light		Lift Point
	Light		Lubricating Oil		Malfunction
	No Open Flame		Oil Tank		Outboard Drive
	Outboard Drive Tilt		Pressure		Propeller
	Propshaft Power		Propulsion System Trim		Propulsion System Trim, Bow Down
	Propulsion System Trim, Bow Up		Pump		Read Owner's Manual
	Seawater		Shift Only Fwd-N-Rev.		Sling Location
	Tank		Throttle/Shift		Transmission
	Transmission Oil		Transmission Oil Filter		Transmission Oil Level
	Transmission Oil Malfunction		Transmission Oil Pressure		Transmission Oil Temperature
	Trim Tab Operation		Trim Tab Operation, Bow Down		Trim Tab Operation, Bow Up
	Volume Empty		Volume Full		Volume Half Full
	Warning		Warning, Electrical Hazard		Warning, Fire Risk
	Warning, Hot		Waste Water, Sewage		Water Flushing Connector
	Windshield Washer Tank		Windshield Wiper & Washer		



LIMITED WARRANTY

Avanti warrants to the original purchasers of its 1999 model boats, purchased from an authorized dealer, operated under normal, noncommercial use that the selling dealer will: (A) Repair any structural hull defect which occurs within five (5) years of the date of delivery; and (B) Repair or replace any parts found to be defective in factory material or workmanship within one (1) year of the date of delivery.

What Is Not Covered

This limited warranty does not apply to:

1. Engines, drive trains, controls, props, batteries, or other equipment or accessories carrying their own individual warranties;
2. Engines, parts or accessories not installed by Avanti;
3. Plexiglass windscreen breakage; rainwater leakage on runabout models; rainwater leakage through convertible tops; minor gelcoat discoloration, cracks or crazing or air voids;
4. Hull blisters that form below the waterline;
5. Normal deterioration, i.e. wear, tear, or corrosion of hardware, vinyl, tops, vinyl and fabric upholstery, plastic, metal, wood, or trim tape;
6. Any Avanti boat used for commercial purposes;
7. Any defect caused by failure of the customer to provide reasonable care and maintenance.

Other Limitations

THERE ARE NO OTHER EXPRESS WARRANTIES ON THIS BOAT. TO THE EXTENT ALLOWED BY LAW:

1. ANY IMPLIED WARRANTY OF MERCHANTABILITY OR FITNESS FOR A PARTICULAR PURPOSE IS LIMITED TO THE DURATION OF ONE YEAR.
2. Neither Avanti nor the selling dealer shall have any responsibility for loss of use of the boat, loss of time, inconvenience, commercial loss or consequential damages.
3. Some jurisdictions do not allow limitations on how long any implied warranty lasts, so the above limitation may not apply to you. Some jurisdictions do not allow the exclusion or limitation of incidental or consequential damages, so the above limitation or exclusion may not apply to you. This limited warranty gives you specific legal rights, and you may also have other rights which vary from state to state.

Your Obligation

In order to comply with regulations, it is essential that your limited warranty registration card be submitted within 30 days of delivery of your boat. Return of the limited warranty registration card is a condition precedent to limited warranty coverage. Before any warranty work is performed, we require that you contact your dealer to request warranty assistance.

YOU MUST GIVE US WRITTEN NOTICE OF YOUR WARRANTY CLAIM PRIOR TO THE EXPIRATION OF YOUR LIMITED WARRANTY AND ALLOW US AN OPPORTUNITY TO RESOLVE THE MATTER.

We require that you return your boat, at your expense, to your selling dealer or, if necessary, to the Avanti factory. You will be responsible for all transportation, haulouts and other expenses incurred in returning the boat for warranty service.

Avanti Marine Corporation

PO Box 9029

Everett, WA 98206

Phone: 360-435-8957

FAX: 360-403-4235

