

**BAYLINER<sup>®</sup>**

185 & 205

Owner's Manual *Supplement*



**Engine Serial Number:** \_\_\_\_\_

**Hull Identification Number:** \_\_\_\_\_

***Hull Identification Number***

The Hull Identification Number (HIN) is located on the starboard side of the transom. Be sure to record the HIN (and the engine serial numbers) in the space provided above. Please refer to the HIN for any correspondence or orders.

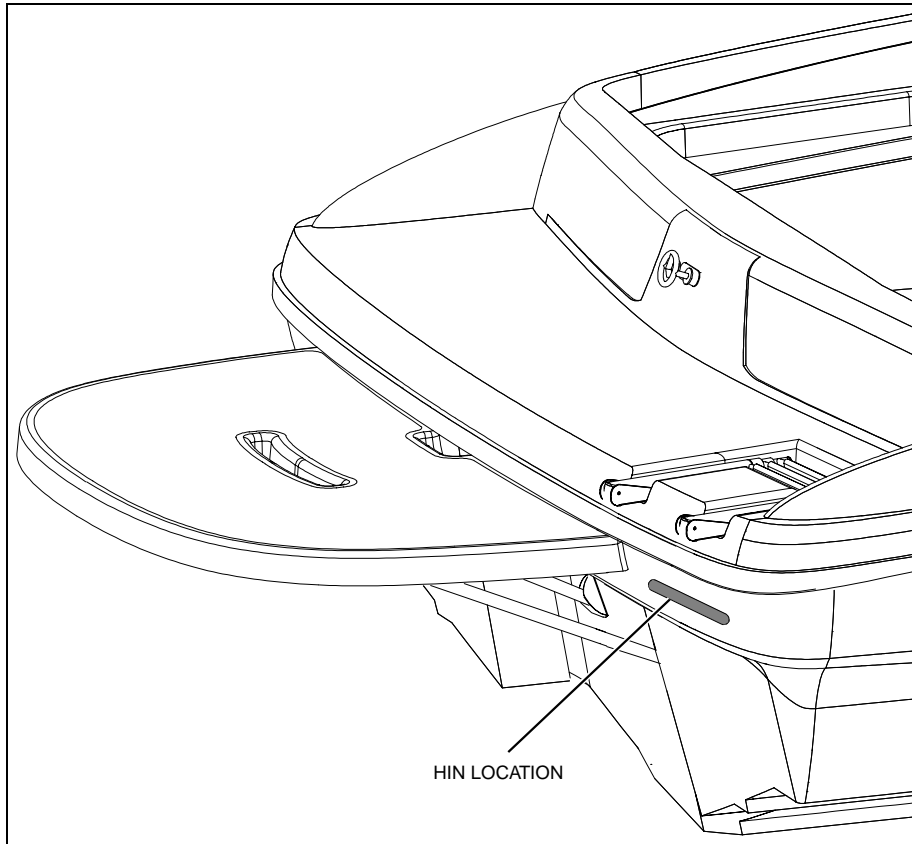

**© 2002 Bayliner Technical Publications. All rights reserved.**

No part of this publication may be reproduced, stored in any retrieval system, or transmitted in any form by any means, electronic, mechanical, photocopying, recording or otherwise, without prior written permission of Bayliner.

Printed in the United States of America.

**General Notes**

The material in this document is for information only and is subject to change without notice. While reasonable efforts have been made in the preparation of this document to assure its accuracy, Bayliner assumes no liability resulting from errors or omissions in this document, or from the use of information contained herein. Due to our commitment to product improvement, Bayliner reserves the right to make changes in the product design, specifications, and equipment at any time without notice or obligation. Illustrations and/or photos may show optional equipment.

All Bayliner products meet or exceed USCG (United States Coast Guard) and/or NMMA (National Marine Manufacturer's Association) construction standards. Manufactured with 1,1,1 Trichloroethane, a substance which harms public health and environment during the manufacturing process by destroying ozone in the upper atmosphere.

**Proprietary Rights**

This document discloses subject matter in which Bayliner has proprietary rights. The information and design disclosed herein were originated by and are the property of Bayliner. Neither receipt nor possession thereof confers or transfers any right to reproduce, copy, alter or disclose the document or any part thereof, any information contained therein, or to construct boats or any item from it, except by written permission from or written agreement with Bayliner. This document is to be returned upon request to Bayliner.

# CONTENTS

---

## **1 Chapter 1: Welcome Aboard!**

- 1 Dealer Service
- 1 About Your Limited Warranty
- 1 Boating Experience
- 2 Safety Standards
- 2 Engine & Accessories Guidelines
- 2 Engine & Accessories Literature
- 3 Qualified Maintenance
- 3 Special Care For Moored Boats
- 4 Carbon Monoxide (CO)
  - 4 *Sources of CO*

## **5 Chapter 2: Product Specifications**

- 5 185
- 6 205

## **7 Chapter 3: Locations**

- 7 Exterior Views
  - 7 *Hull Views*
  - 8 *Extended Swim Platform (If Equipped)*
  - 9 *185 Deck View*
  - 10 *205 Deck View*
- 11 Component Locations

## **12 Chapter 4: Propulsion & Related Systems**

- 12 Engine
- 12 Engine Room Ventilation System
- 13 Fuel System
  - 13 *Fuel Fill and Vent*
  - 13 *Fuel Filters*

## **14 Chapter 5: Controls & Gauges**

- 14 Steering
- 14 Shift/Throttle Lever
- 14 Power Trim and Tilt
- 14 Gauges
  - 14 *Cleaning Gauges*
  - 14 *Gauge Fogging*
  - 14 *Radio Transmission Interference*
  - 14 *Fuel Gauge*

## **15 Chapter 6: Plumbing**

- 15 Bilge Pump

## **17 Chapter 7: Deck Equipment**

- 17 Cleats and Tow Eyes
- 17 Ski Tow Ring
- 18 Ski-Tow Tower (If Equipped)
  - 18 *Attaching the Ski-Tow Rope*
  - 19 *Folding Ski-Tow Tower (205 Only)*
- 20 Canvas (If Equipped)
  - 20 *Canvas Top (If Equipped)*
  - 21 *185 Bimini Top (If Equipped)*
  - 22 *205 Bimini Top (If Equipped)*

---

**23 Chapter 8: Entertainment Systems**

23 Audio System

**24 Chapter 9: Convertible Seats, Beds, & Tables**

24 Sleeper Seats (If Equipped)

*24 Operating Positions*

*24 Lounge positions*

25 Jump Seat To Sunlounge Conversion  
(If Equipped)

**26 Chapter 10: Lights**

26 Care and Maintenance

26 Navigation Lights

**27 Chapter 11: Electrical System**

28 12-Volt DC System

*28 Battery*

*28 Fuses and Circuit Breakers*

*28 Alternator*

*28 12-Volt Accessory Outlet*

29 Electrical Routings

*29 185 & 205 Deck Electrical Harness*

*30 Hull Electrical Harness*

31 Wire Diagram

**32 Important Records**

**33 Float Plan**

## Hazard Boxes & Symbols







The hazard boxes and symbols shown below are used throughout this supplement to call attention to potentially dangerous situations which could lead to either personal injury or product damage. **Read ALL warnings carefully and follow all safety instructions.**

 <b>DANGER!</b>
<b>This box alerts you to immediate hazards which WILL cause severe personal injury or death if the warning is ignored.</b>

 <b>WARNING!</b>
<b>This box alerts you to hazards or unsafe practices which COULD result in severe personal injury or death if the warning is ignored.</b>

 <b>CAUTION!</b>
<b>This box alerts you to hazards or unsafe practices which COULD result in minor personal injury or cause product or property damage if the warning is ignored.</b>

<b>NOTICE</b>
<b>This box calls attention to installation, operation or maintenance information, which is important to proper operation but is not hazard related.</b>

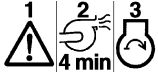
 <b>FIRE HAZARD!</b>	 <b>EXPLOSION HAZARD!</b>	 <b>ELECTRICAL HAZARD!</b>	 <b>HOT HAZARD!</b>
 <b>CO POISONING HAZARD!</b>	 <b>FALLING HAZARD!</b>	 <b>ROTATING PROPELLER HAZARD!</b>	
 <b>NO OPEN FLAME!</b>	 <b>RUN BILGE BLOWERS FOR 4 MINUTES!</b>		

## Chapter 1: Welcome Aboard!

---

This *Owner's Manual Supplement* provides specific information about your boat that is not covered in the *Sport Boat Owner's Manual*. Please study the *Sport Boat Owner's Manual* and this supplement carefully. Keep the *Sport Boat Owner's Manual* and this supplement on your boat in a secure, yet readily available place.

### Dealer Service

- Your dealer is your key to service.
- Ask your dealer to explain all systems before taking delivery of your boat.
- Contact your dealer if you have any problems with your new boat.
- If your dealer cannot help, call our customer service hotline: 360-435-8957 or send us a FAX: 360-403-4235.
- Buy replacement parts from any authorized Bayliner dealer.

### About Your Limited Warranty

- Bayliner offers a Limited Warranty on each new Bayliner purchased through an authorized Bayliner dealer.
- A copy of the Limited Warranty was included in your owner's packet.
- If you did not receive a copy of the Limited Warranty, please contact your dealer or call 360-435-8957 for a copy.

### Boating Experience

 <b>WARNING!</b>
<b><i>CONTROL HAZARD!</i> A qualified operator must be in control of the boat at all times. DO NOT operate your boat while under the influence of alcohol or drugs.</b>

If this is your first boat or if you are changing to a type of boat you are not familiar with, for your own comfort and safety, obtain handling and operating experience before assuming command of the boat.

Take one of the boating safety classes offered by the U.S. Power Squadrons or the U.S. Coast Guard Auxiliary. For more course information, including dates and locations of upcoming classes, contact the organizations directly:

- U.S. Power Squadrons: 1-888-FOR-USPS (1-888-367-8777) or on the Internet at: <http://www.usps.org>
- U.S. Coast Guard Auxiliary: 1-800-368-5647 or on the Internet at: <http://www.cgaux.org>

Outside the United States, your selling dealer, national sailing federation or local boat club can advise you of local sea schools or competent instructors.

## Safety Standards

**⚠ DANGER!**



**PERSONAL SAFETY HAZARD! DO NOT** allow anyone to ride on parts of the boat not designated for such use. Sitting on seat backs, lounging on the forward deck, bow riding, gunwale riding or occupying the transom platform while underway is especially hazardous and will cause personal injury or death.

**⚠ DANGER!**

**PERSONAL SAFETY HAZARD! ALWAYS** secure the anchor and other loose objects before getting underway. The anchor and other items that are not properly secured can come loose when the boat is moving and cause personal injury or death.

- Your boat's mechanical and electrical systems were designed to meet safety standards in effect at the time it was built.
- Some of these standards were mandated by law, all of them were designed to insure your safety, and the safety of other people, vessels and property.

In addition to this **owner's manual supplement**, please read the *Sport Boat Owner's Manual* and all accessory instructions for important safety standards and hazard information.

## Engine & Accessories Guidelines

**NOTICE**

**When storing your boat please refer to your engine's operation and maintenance manuals.**

- Your boat's engine and accessories were selected to provide optimum performance and service.
- Installing a different engine or other accessories may cause unwanted handling characteristics.
- Should you choose to install a different engine or to add accessories that will affect the boat's running trim, have an experienced marine technician perform a safety inspection and handling test before operating your boat again.

**Certain modifications to your boat can result in cancellation of your warranty protection.** Always check with your dealer before making any modifications to your boat.

## Engine & Accessories Literature

- The engine and accessories installed on your boat come with their own operation and maintenance manuals.
- Read and understand these manuals before using the engine and accessories.
- Unless noted otherwise, all engine and accessory literature referred to in this supplement is included in your owner's packet.



## Qualified Maintenance



### WARNING!

**To maintain the integrity and safety of your boat, allow only qualified personnel to perform maintenance on, or in any way modify: The steering system, propulsion system, engine control system, fuel system, environmental control system, electrical system or navigational system.**

- Failure to maintain your boat's systems (listed in the warning above) as designed could violate the laws in your jurisdiction and could expose you and other people to the danger of bodily injury or accidental death.
- Follow the instructions provided in the *Sport Boat Owner's Manual*, this *Owner's Manual Supplement*, the engine owner's manual and all accessory instruction sheets and manuals.

## Special Care For Moored Boats

### NOTICE

- **To help seal the hull bottom and reduce the possibility of gelcoat blistering on moored boats, apply an epoxy barrier coating, such as INTERLUX, *Interprotect 2000E/2001E*. The barrier coating should be covered with several coats of anti-fouling paint.**
- **Many states regulate the chemical content of bottom paints in order to meet environmental standards. Check with your local dealer about recommended bottom paints, and about the laws in effect in your area.**

- Whether moored in saltwater or freshwater, your boat will collect marine growth on its hull bottom.
- This will detract from the boat's beauty, greatly affect its performance and may damage the gelcoat.
- Periodically haul the boat out of the water and scrub the hull bottom with a bristle brush and a solution of soap and water.

## Carbon Monoxide (CO)

 **DANGER!**



***CARBON MONOXIDE POISONING HAZARD!***

**Carbon monoxide gas (CO) is colorless, odorless, and extremely dangerous. All engines, generators, and fuel burning appliances produce CO as exhaust. Direct and prolonged exposure to CO will cause BRAIN DAMAGE or DEATH.**

**Signs of CO poisoning include:**

- **Headache**
- **Nausea**
- **Dizziness**
- **Drowsiness**

- CO poisoning causes a significant number of boating deaths each year.
- Called the "silent killer", CO is an extremely toxic, colorless, odorless and tasteless gas.
- Breathing CO blocks the ability of your blood to carry oxygen.
- The effects are cumulative, even low levels of exposure can result in injury or death.

### *Factors increasing the effects of CO poisoning include:*

- Age
- Smokers or people exposed to high concentrations of cigarette smoke
- Consumption of alcohol
- Lung disorders
- Heart problems
- Pregnancy

### **Sources of CO**

#### *To correct stationary situations a and/or b:*

- Close all windows, portlights and hatches.
- If possible, move your boat away from source of CO.

#### *To correct running situations c and/or d:*

- Trim bow down.
- Open windows and canvas.
- When possible, run boat so that prevailing winds help dissipate exhaust.

**IMMEDIATELY take corrective action if CO is detected or suspected.**

**Sources of CO include:**

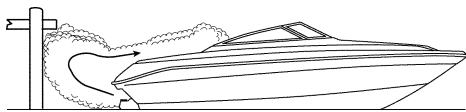

a. Using engine, generator, or other fuel burning device when boat is moored in a confined space.

---

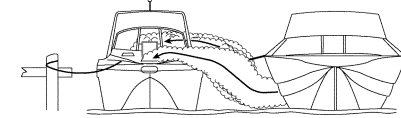

b. Mooring too close to another boat that is using its engine, generator, or other fuel burning device.

---

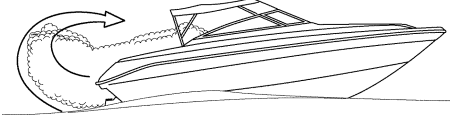

c. Running boat with trim angle of bow too high.

---

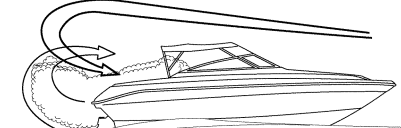

d. Running boat without through ventilation (station wagon effect).

## Chapter 2: Product Specifications

185

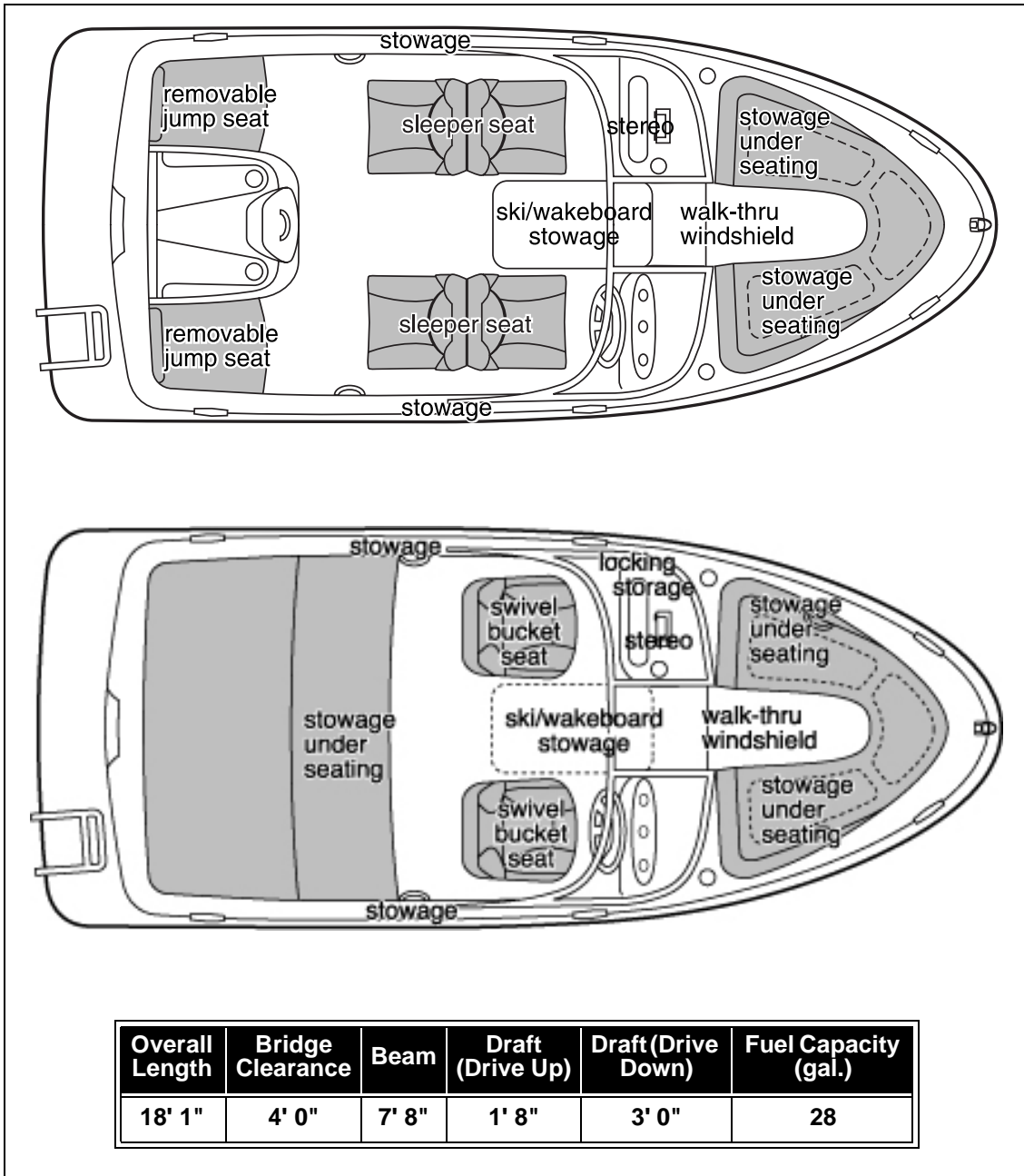

205

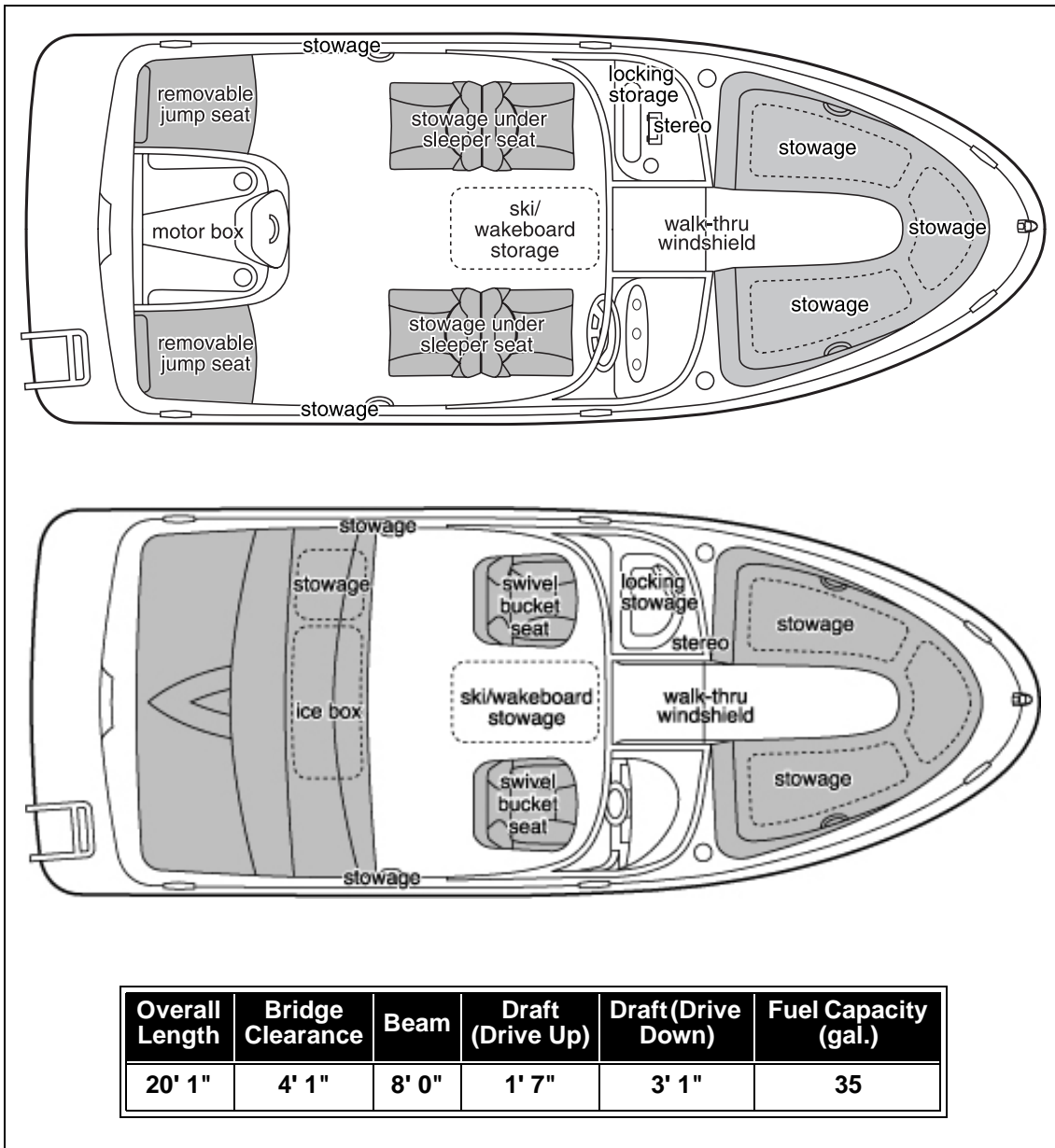

Overall Length	Bridge Clearance	Beam	Draft (Drive Up)	Draft (Drive Down)	Fuel Capacity (gal.)
20' 1"	4' 1"	8' 0"	1' 7"	3' 1"	35

## Chapter 3: Locations

### Exterior Views

#### Hull Views

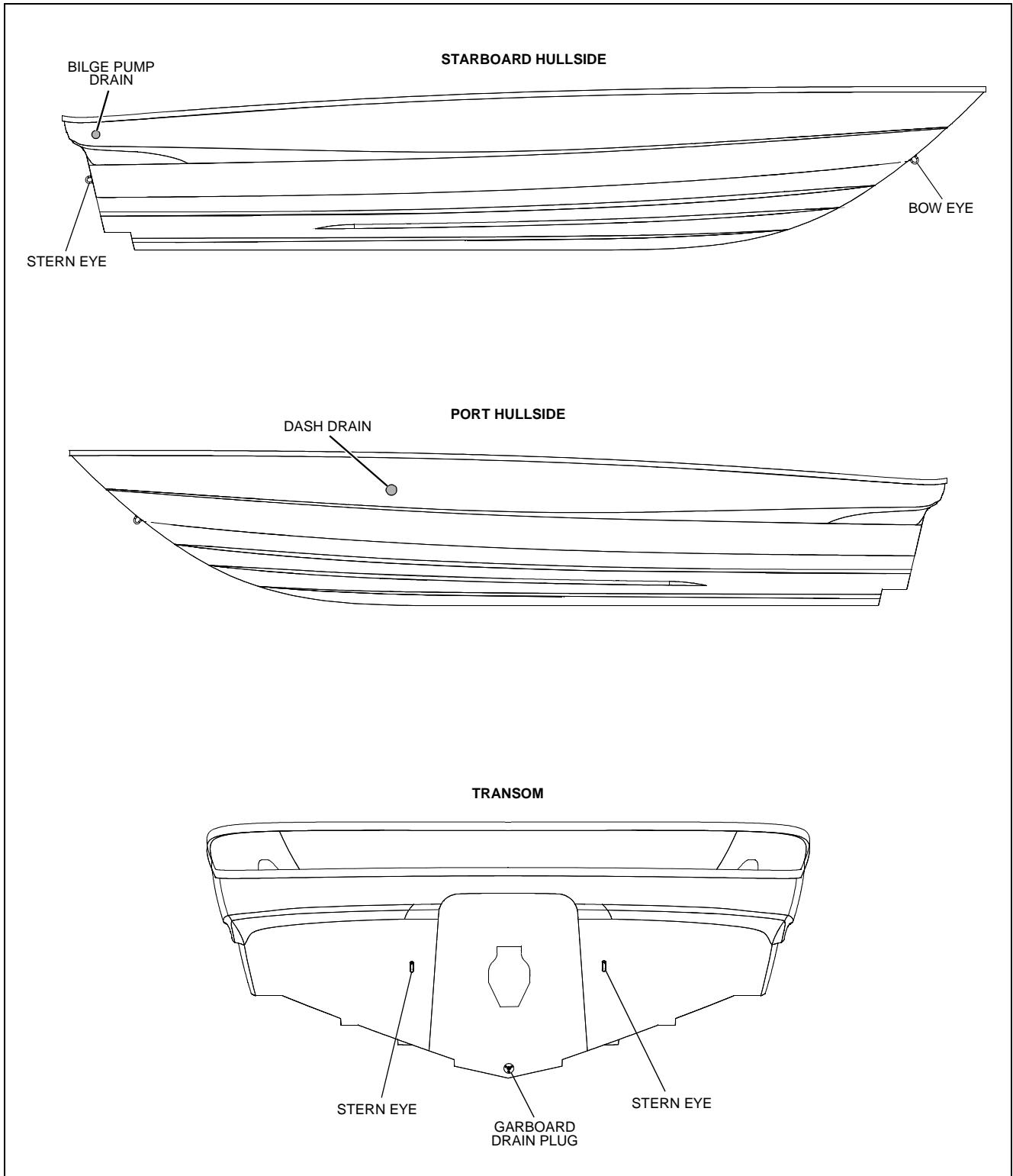

**Extended Swim Platform (If Equipped)**

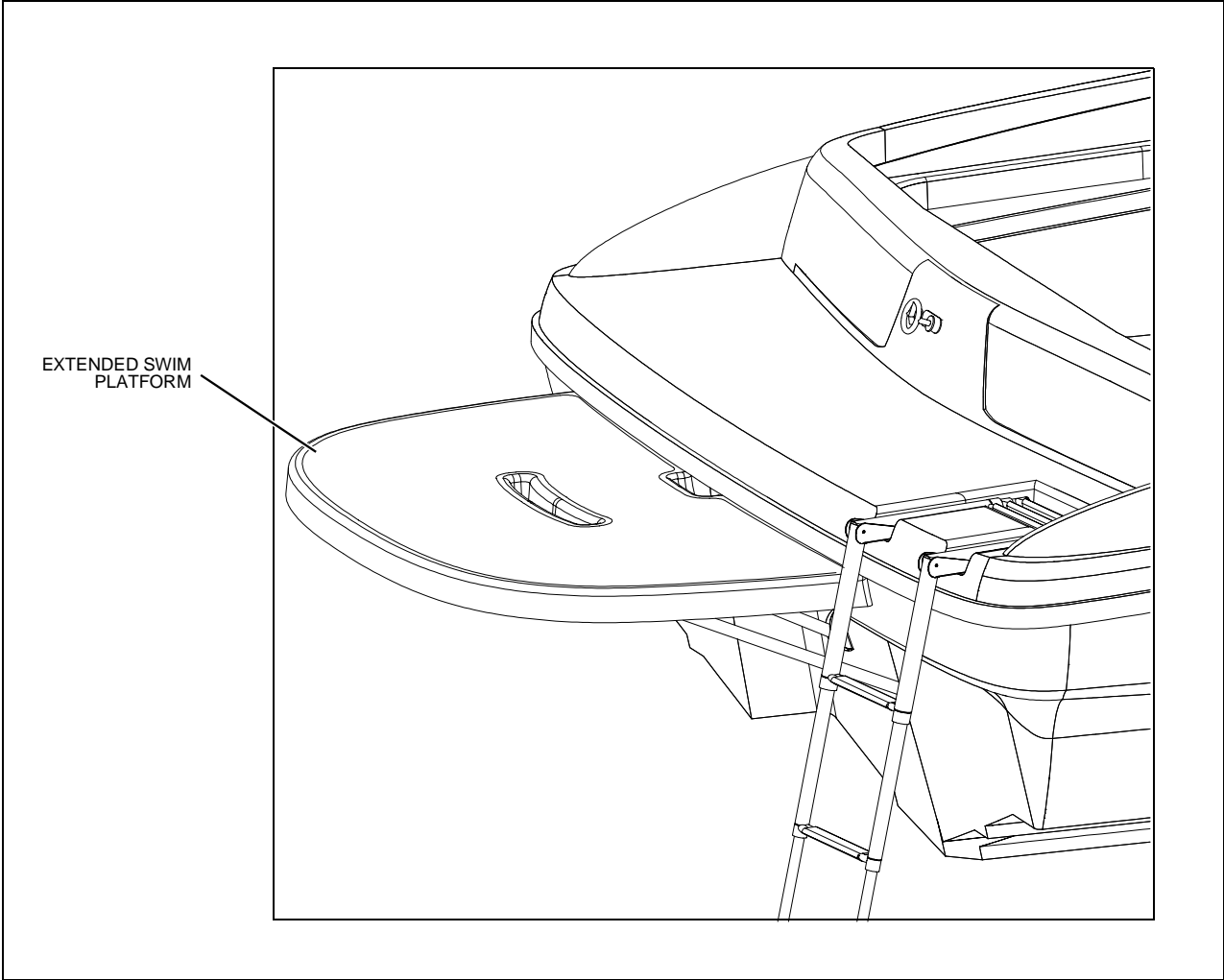

### 185 Deck View

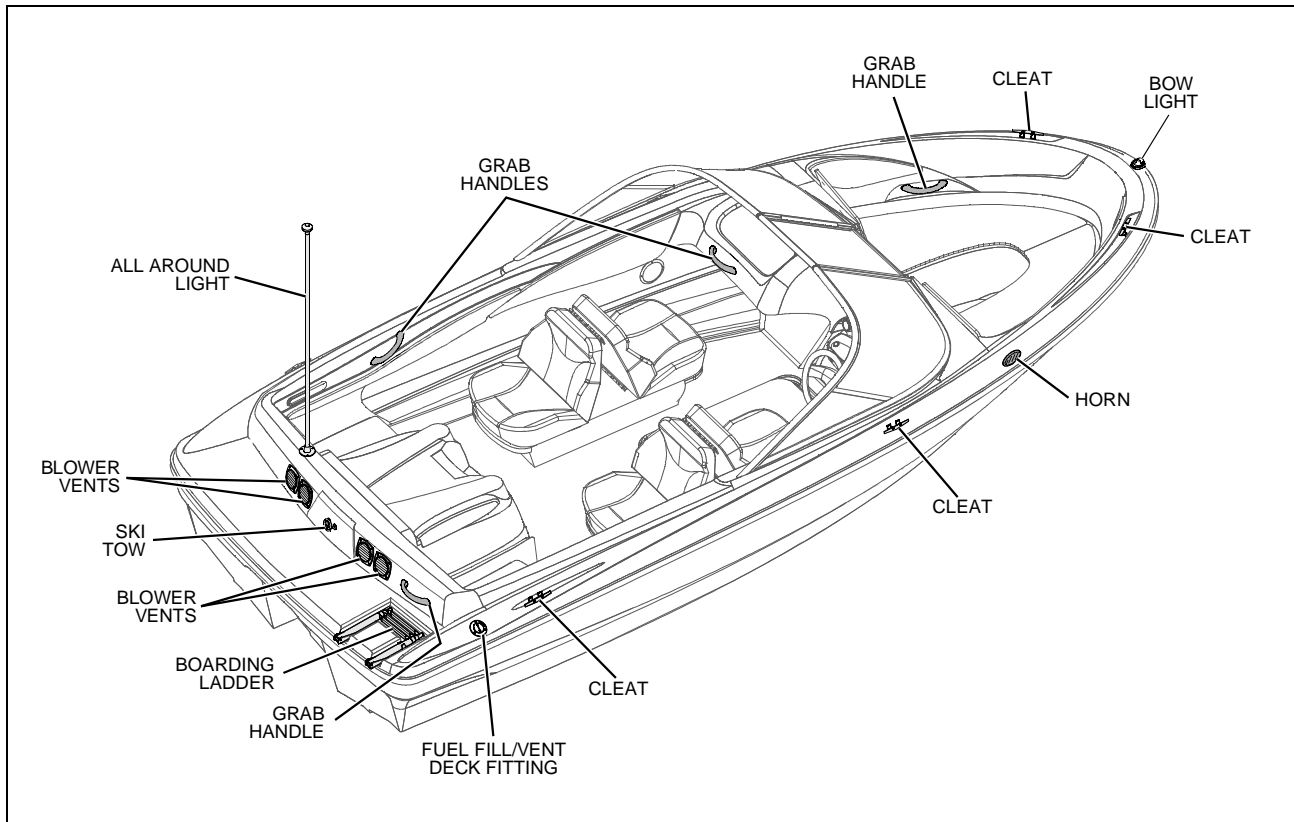

**205 Deck View**

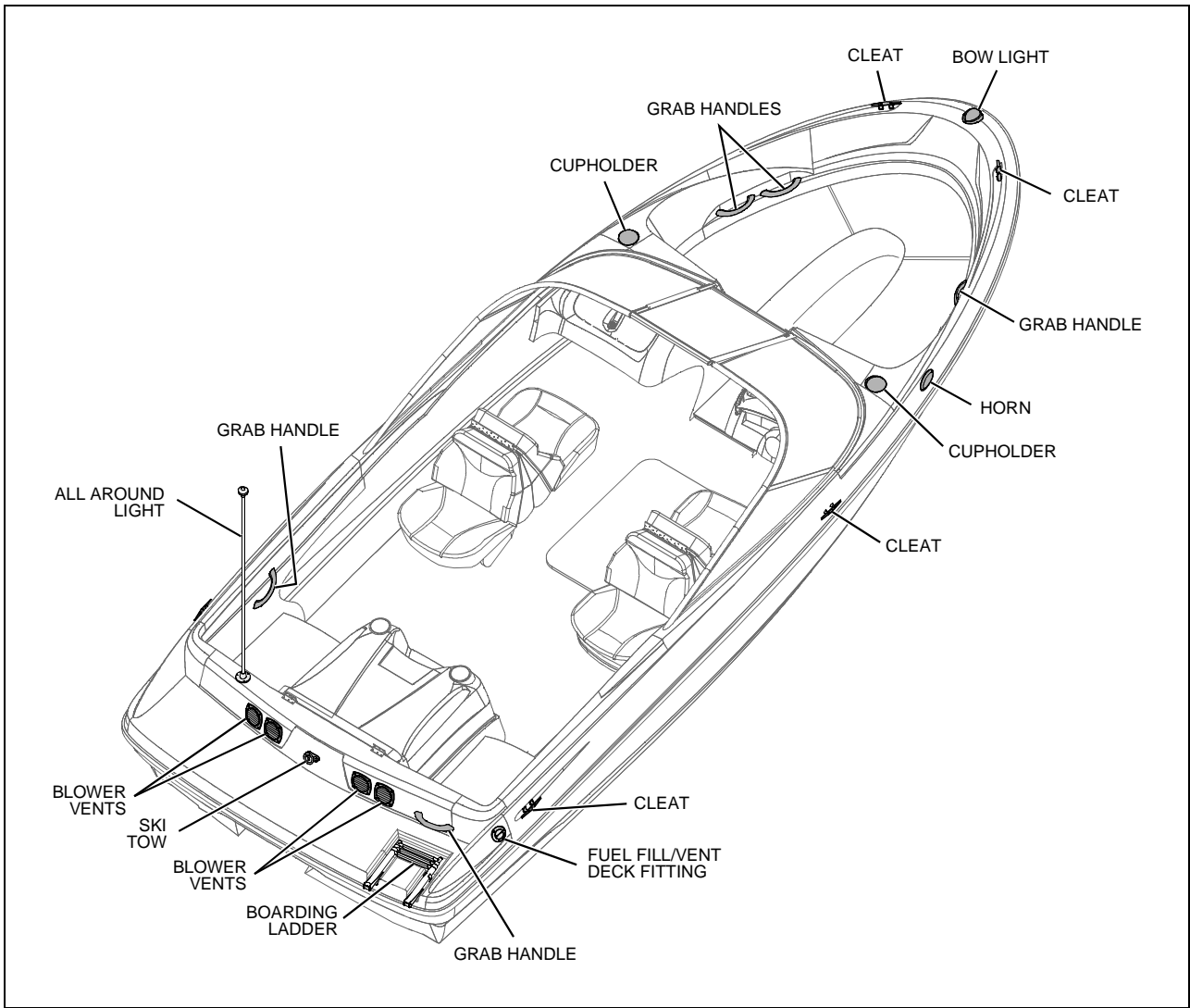



## Component Locations

**12-Volt Accessory Outlet:** At the helm on the dash panel.

**Battery:** On the port side of the engine compartment

**Bilge Pump:** In the engine compartment, forward of the engine.

**Engine Circuit Breaker:** On the engine.

**Fuse Block:** At the helm, under the dash panel.

**Fuel Fill:** On the starboard side of the aft deck.

**Navigation Lights:** Red and green light at the bow. White all-around light on the stern.

## Chapter 4: Propulsion & Related Systems

### Engine

Be sure to read and understand the engine operation and maintenance manuals before starting or doing any maintenance on the engine.

### Engine Room Ventilation System

**! WARNING!**



**FIRE/EXPLOSION HAZARD**

- Use of the blower system is **NOT A GUARANTEE** that explosive fumes have been removed.
- If you smell fuel, **DO NOT** start the engine and **DO NOT** turn on any electrical devices.
- If you smell fuel and the engine is already running, **SHUT OFF** the engine and **TURN OFF** all electrical devices. Investigate immediately.
- **DO NOT** obstruct or modify the ventilation system.

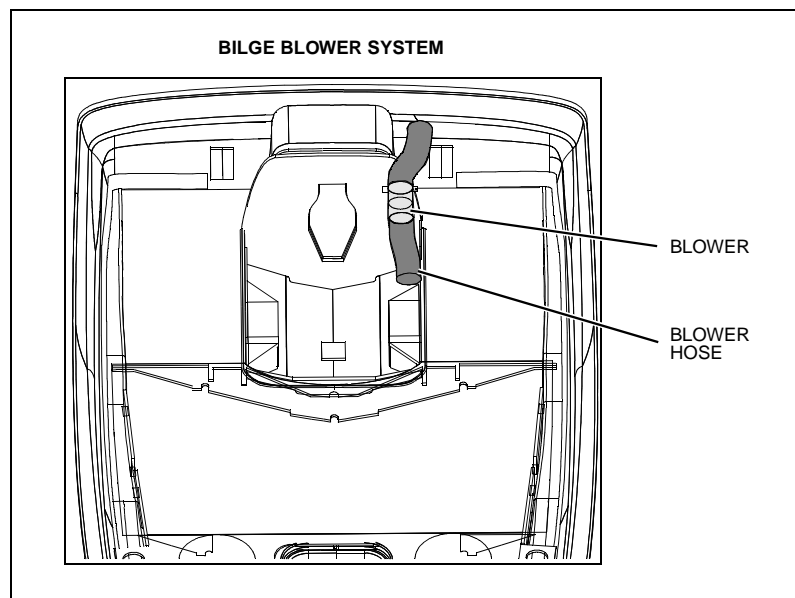

- The bilge blower removes explosive fuel fumes from the engine compartment.
- Fresh air is drawn into the compartment through the deck vents.
- The bilge blower switch is at the helm.

To make sure the engine compartment is ventilated with fresh air, run the bilge blower:

- For at least four minutes before starting the engine.
- During starting.
- Anytime your boat is running below cruising speed.

## Fuel System

**⚠ WARNING!**



***FIRE, EXPLOSION AND OPEN FLAME HAZARD!***

- It is very important that the fuel system be inspected thoroughly the first time it is filled and at each subsequent filling.
- The fueling instructions in the *Sport Boat Owner's Manual* and the fuel recommendations in the engine operation manual must be followed.

**⚠ CAUTION**

Avoid the storage or handling of gear near the fuel lines, fittings and tank.

### Fuel Fill and Vent

- The fuel fill/vent fitting is marked "GAS".
- If you experience difficulty filling the fuel tank, check to see that the fuel fill hose and vent hose are free of clogs and kinks.

### Fuel Filters

- The fuel pickup tube (located inside the fuel tank) is equipped with a fine mesh screen filter.
- In addition, when supplied by the engine manufacturer, a fuel filter is installed on the engine.
- Periodically replace the fuel filters to make sure they remain clean and free of debris.
- Talk to your selling dealer or local marina about fuel additives that help prevent fungus or other buildup in your fuel tank.

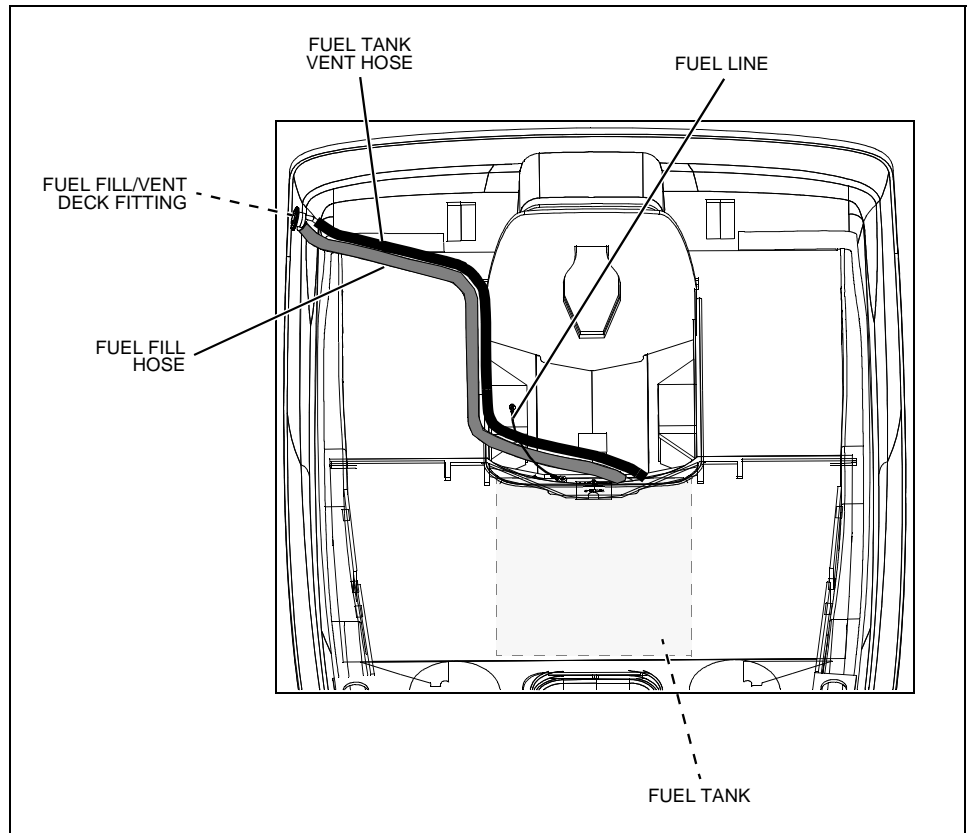

## Chapter 5: Controls & Gauges

---

### Steering

- Refer to the engine manual for steering system details.

### Shift/Throttle Lever

 <b>WARNING!</b>
<b><i>LOSS OF CONTROL HAZARD!</i></b> <b>Improper maintenance of shift/throttle hardware may cause a sudden loss of control!</b>

- Carefully read and understand all of the information about the shift/throttle in the *Sport Boat Owner's Manual*.
- Also, read and understand the shifter/throttle and engine manuals.

### Power Trim and Tilt

- The stern drive on your boat is equipped with power trim and tilt.
- Trim and tilt instructions are provided in the engine operation manual and the shifter/throttle manual.

### Gauges

#### *Cleaning Gauges*

 <b>CAUTION!</b>
<b><i>PRODUCT or PROPERTY DAMAGE HAZARD!</i></b>
<ul style="list-style-type: none"> <li>• Use only mild soap and water to clean the gauge lenses and bezels.</li> <li>• Use of other cleaners, including common window cleaning solutions, may cause the lenses to crack.</li> <li>• Lenses cracked in this manner will not be covered by our warranty.</li> </ul>

#### *Gauge Fogging*

- Moisture may occasionally find its way into the gauges causing lens fogging.
- Turning on the gauge lights will help dry the lenses.
- Fogging will not harm the gauges.

#### *Radio Transmission Interference*

VHF or other radio transmissions may cause brief erratic readings on the tachometer. This will not damage this gauge or affect its accuracy when not transmitting.

#### *Fuel Gauge*

It is normal for the pointer on your fuel gauge to bounce as fuel sloshes back and forth in the fuel tank.

## Chapter 6: Plumbing

### Bilge Pump

#### NOTICE

Discharge of oil, oil waste or fuel into navigable waters is prohibited by law. Violators are subject to legal action by the local authorities.

- Your boat is equipped with a bilge pump for pumping water out of the bilge.
- The bilge pump is controlled by a switch at the helm.

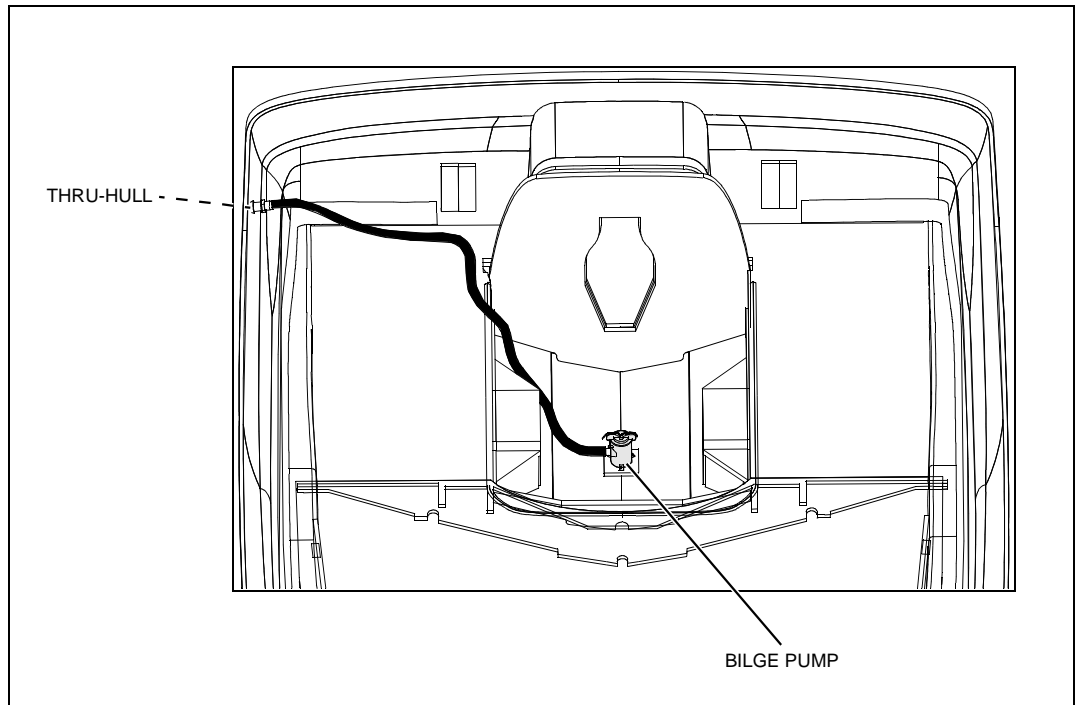

***Bilge Pump Testing***

- The bilge pump is critical to the safety of your boat.
- Check the bilge pump often to make sure it is working.

Test the pump as follows:

1. Turn on the bilge pump switch at the helm.
2. Any water in the bilge should pump overboard.
- If the pump motor is running, but not pumping, inspect the discharge hose for a kink or collapsed area.
- If no problems are found, check the bilge pump housing for clogging debris as follows:

1. Remove the power cartridge:
  - a. Lift the tab while rotating the fins counter-clockwise.
  - b. Lift out the power cartridge.
  - c. Clear the outer housing of debris.
2. Reinstall the power cartridge:
  - a. Make sure the "O" ring is properly seated.
  - b. Coat the "O" ring with a light film of vegetable or mineral oil.
  - c. Align the cams on either side of the power cartridge with the two slots on the outer housing.
  - d. Press the power cartridge into the housing while twisting clockwise.
3. Check the reinstallation by trying to twist the fins counter-clockwise without lifting the tab; the cartridge should stay in place.

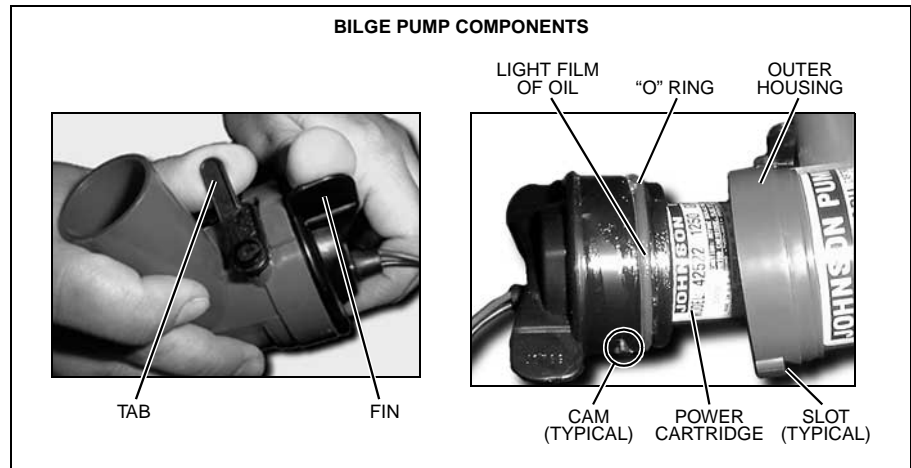

## Chapter 7: Deck Equipment

---

### Cleats and Tow Eyes

 **WARNING!**

***PERSONAL INJURY and /or PRODUCT or PROPERTY DAMAGE HAZARD!***

- **NEVER lift the boat using the bow and stern eyes or the cleats.**

Carefully read the section on towing in the *Sport Boat Owner's Manual* before:

- Towing anything behind the boat.
- Being towed by another vessel.

### Ski Tow Ring

Your boat has a ski tow ring. Attach tow rope as shown in the photo.

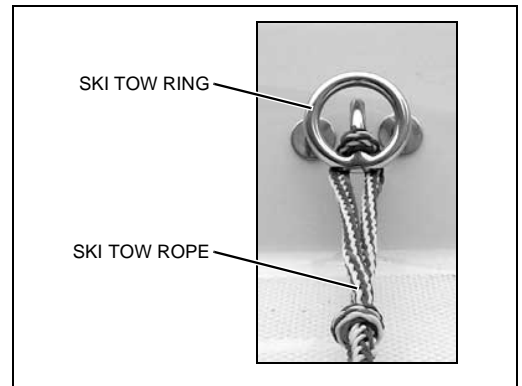

## Ski-Tow Tower (If Equipped)



### WARNING!

**PERSONAL INJURY and /or PRODUCT or PROPERTY DAMAGE HAZARD!**

Failure to follow these guidelines can result in injury or death:

- Read all warning labels on ski-tow tower.
- Before each use, make sure all bolts are in place and tight.
- Only tow water skis, wakeboards, or recreational towables.
- Do not tow parasails, kites, or other boats.
- Do not tow more than two persons at one time.
- Do not climb on, sit on, stand on, jump off or dive off tower.
- Never allow passengers to sit behind tow rope attachment point.
- Use caution with skier in tow as tow rope may snap back into cockpit when released.
- Never allow loose tow rope ends to dangle off tower.
- When tower is up, watch for low obstacles such as tree limbs, bridges, or power lines.

### Attaching the Ski-Tow Rope

1. Place the ski-tow rope loop (A) over the ski-tow pylon (B).
2. Put a twist in the ski-tow rope loop (A) and place over the ski-tow pylon (B) again.

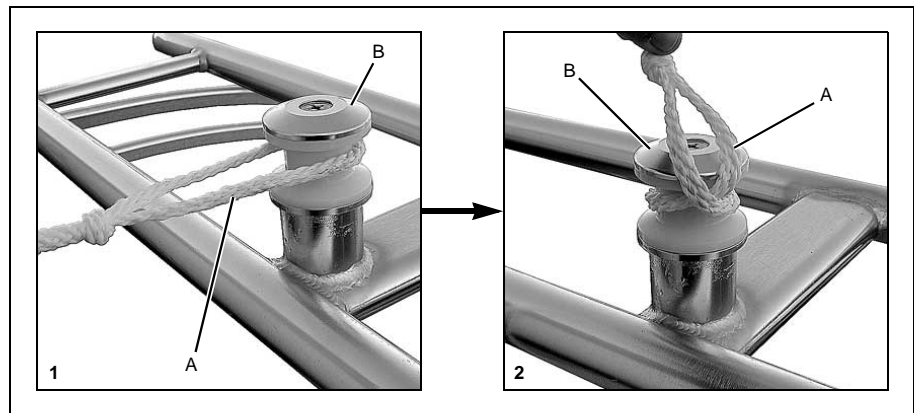

3. Pull ski-tow rope to tighten.

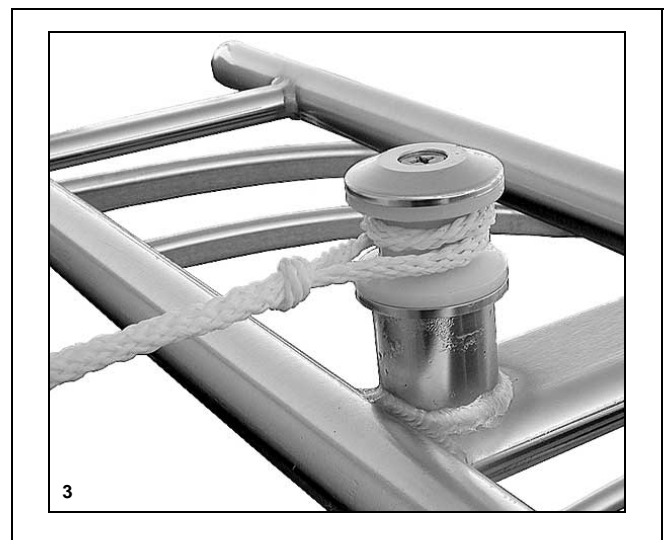



**Folding Ski-Tow Tower (205 Only)****WARNING!****PERSONAL INJURY and /or PRODUCT or PROPERTY DAMAGE HAZARD!**

- Folding or unfolding the ski-tow tower is a two person task.
- Before each use of the folding ski-tow tower, make sure all four lock-down bolts are tightened firmly.
- Read all warning labels on the ski-tow tower.

**To fold the ski-tow tower into the storage position:**

1. Remove the lower lock-down bolt (A) on each side of the tower.

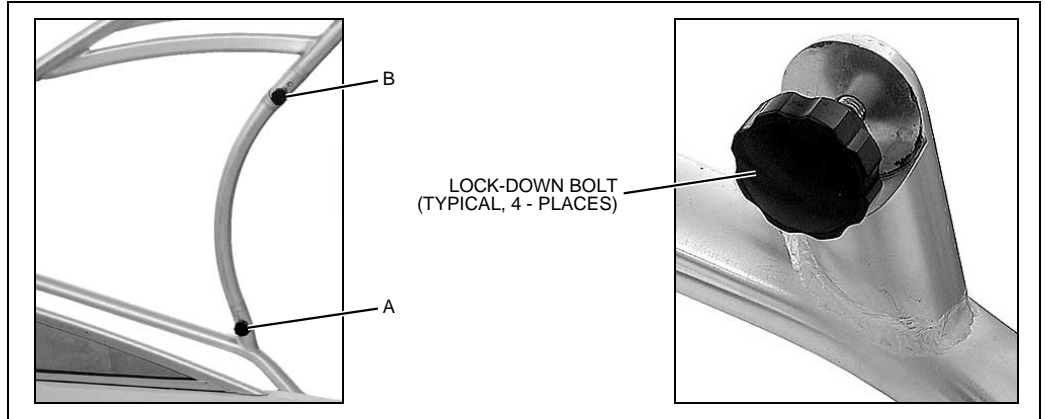

2. Carefully fold the tower forward.
3. Replace the lower lock-down bolts (A).
4. Remove the upper lock-down bolts (B).

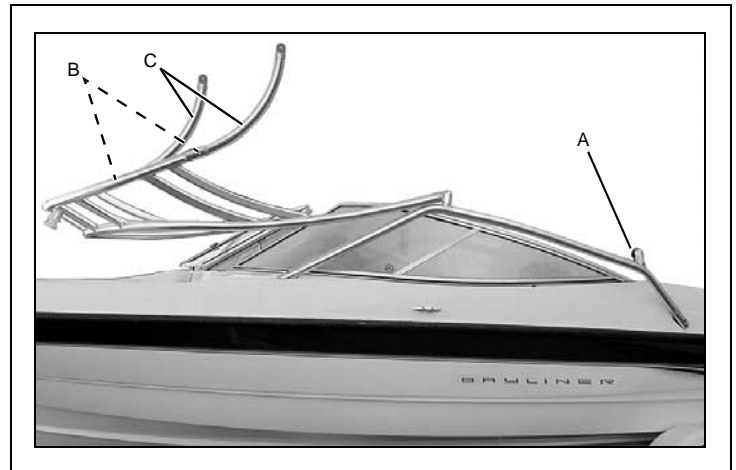

5. Lower the support legs (C).
6. Replace the upper lock-down bolts (B).



To return the tower to the towing position, perform the above steps in reverse order.

## Canvas (If Equipped)



### CAUTION!

Take down and securely stow the canvas top or bimini top, side curtains and back cover before transporting your boat by road.

### Canvas Top (If Equipped)

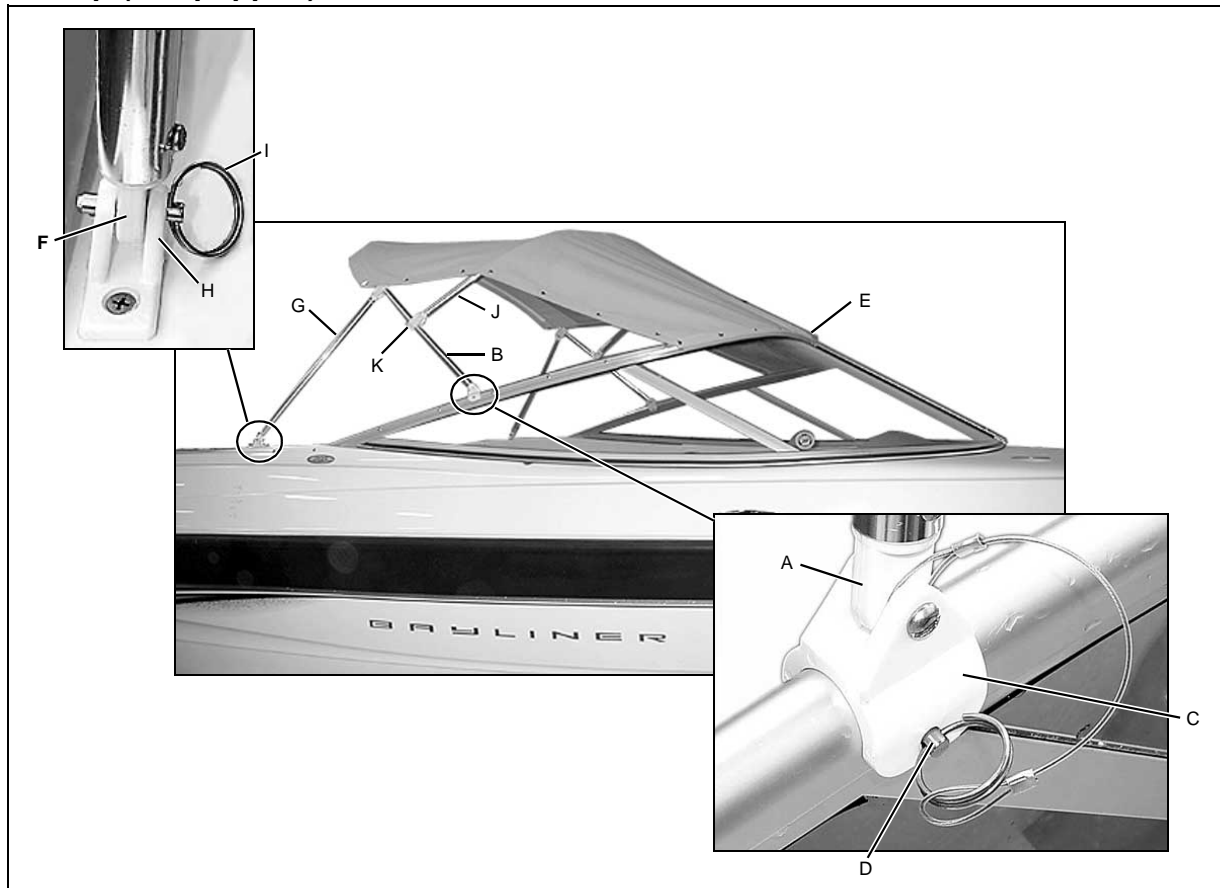

1. Slide the swivel ends (A) of the main bow (B) over the pre-drilled hole on each side windshield frame (C) and secure with the pins (D).
2. Unfold the canvas top and snap the front edge of the top (E) to the windshield frame.
3. Insert the end eyes (F) of the aft braces (G) into the deck hinges (H) and secure it with the pins (I).
4. Align the secondary bow (J) with the center seam of the canvas by loosening or tightening the top straps.
5. No adjustments to the jaw slides (K) should be needed as they are preset during manufacturing. Before attempting to adjust the jaw slide positions, obtain the correct measurements from your selling dealer.
6. If additional canvas (i.e. side curtains or slant back cover) is installed, the canvas top may need readjustment to align the snaps on the canvas with the snaps on the boat.

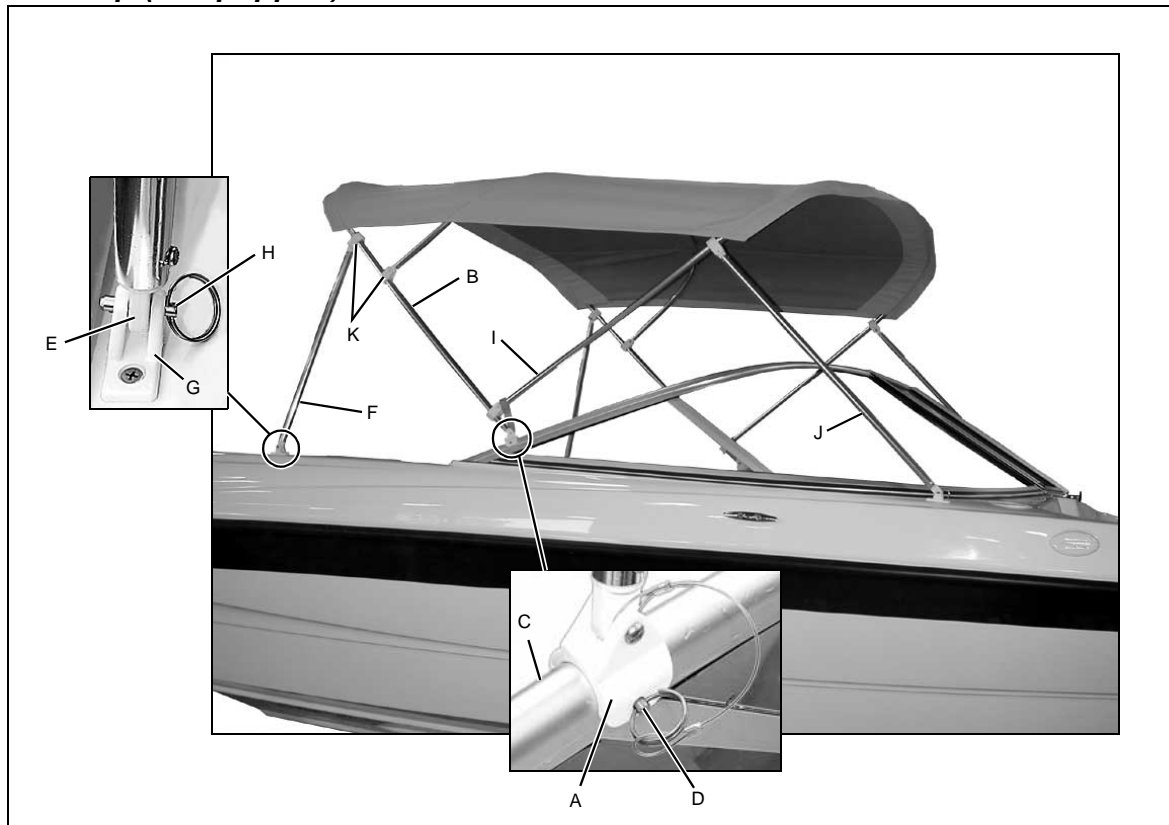
**185 Bimini Top (If Equipped)**

1. Slide the swivel ends (A) of the main bow (B) over the aft pre-drilled holes in the windshield frames (C) and insert the pins (D).
2. Insert the end eyes (E) of the aft braces (F) into the deck hinges (G) and secure it with the pins (H).
3. Pull the secondary bow (I) and insert the end eyes of the forward braces (J) into the deck hinges and secure it with the pins.
4. No adjustments to the jaw slides (K) should be needed as they are preset during manufacturing. Before attempting to adjust the jaw slide positions, obtain the correct measurements from your selling dealer.

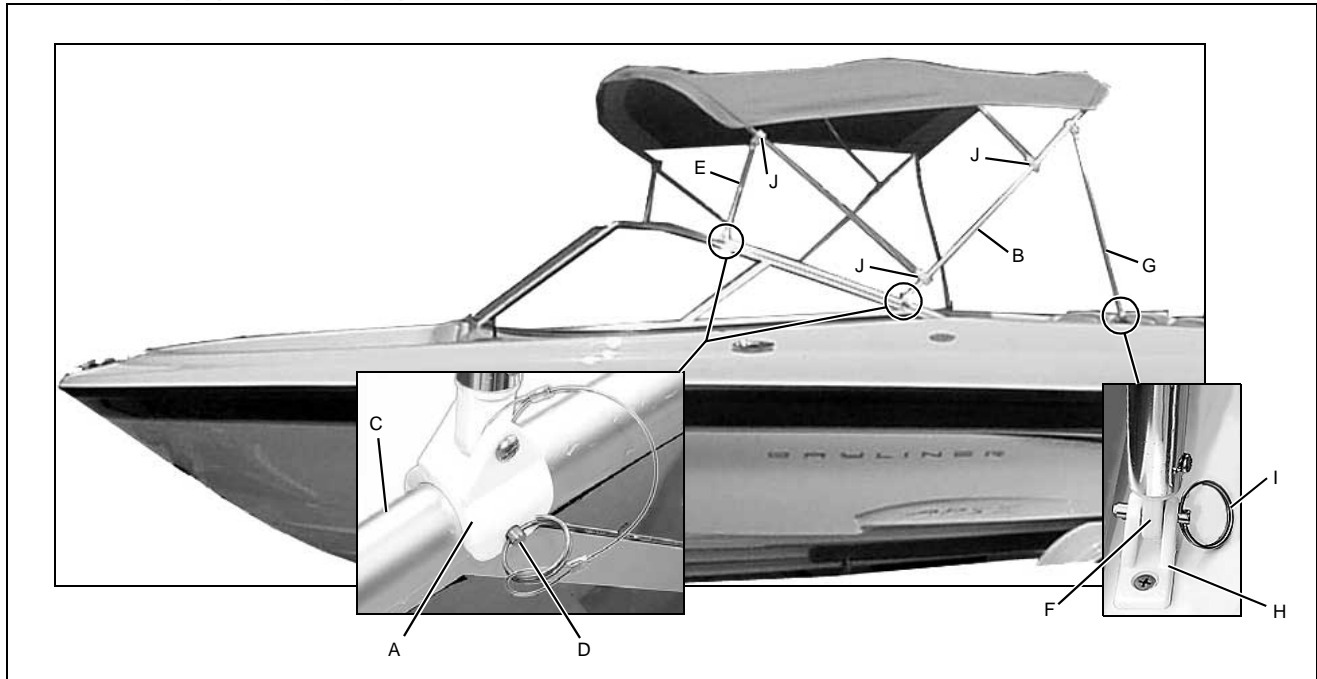
**205 Bimini Top (If Equipped)**

1. Slide the swivel ends (A) of the main bow (B) over the aft pre-drilled holes in the windshield frames (C) and insert the pins (D).
2. Unfold the canvas top and slide the swivel ends of the forward legs (E) over the forward pre-drilled holes in the windshield frames and insert the pins.
3. Slide the eye ends (F) of the aft legs (G) into the deck hinges (H) and insert the pins (I).
4. No adjustments to the bow jaw slides (J) should need to be made as they are preset during manufacturing. Before attempting to adjust the jaw slide positions, obtain the correct measurements from your selling dealer.

## Chapter 8: Entertainment Systems

---

### Audio System

<b>NOTICE</b>
---------------

<b>AM radio reception may be impaired anytime the engine is running.</b>
--

Read and understand the instruction manual for your boat's audio system before using.

## Chapter 9: Convertible Seats, Beds, & Tables

### Sleeper Seats (If Equipped)

- The sleeper seats can be adjusted fore and aft in the upright, operating position.
- The seat bottoms adjust into backrests when the seats are in the lounge position.

#### Operating Positions

##### To slide the seat forward:

1. Lift the forward seat at point (A).
2. Push down on the forward seat at point (B) and pull the seat forward.
3. Lock the forward seat into the desired position by pushing down at point (A).
4. Lift the aft seat at point (C).
5. Push down on the aft seat at point (D) and push the seat forward until the aft seat back is flush against the forward seat back.
6. Lock the aft seat into position by pushing down at point (C).

To slide the seat aft, repeat the steps above, but start with the aft seat.

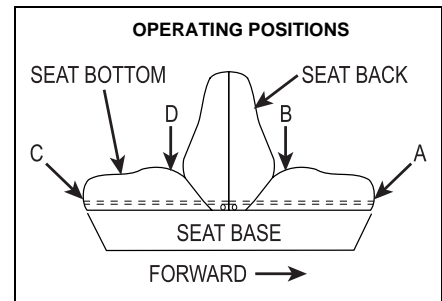

#### Lounge positions

##### To adjust into the flat lounge position:

1. Lift the forward seat at point (A).
2. Push down on the forward seat at point (B) and pull the seat forward until the seat back and bottom are flat.
3. Lift the aft seat at point (C).
4. Push down on the aft seat at point (D) and pull the seat aft until the seat back and bottom are flat.

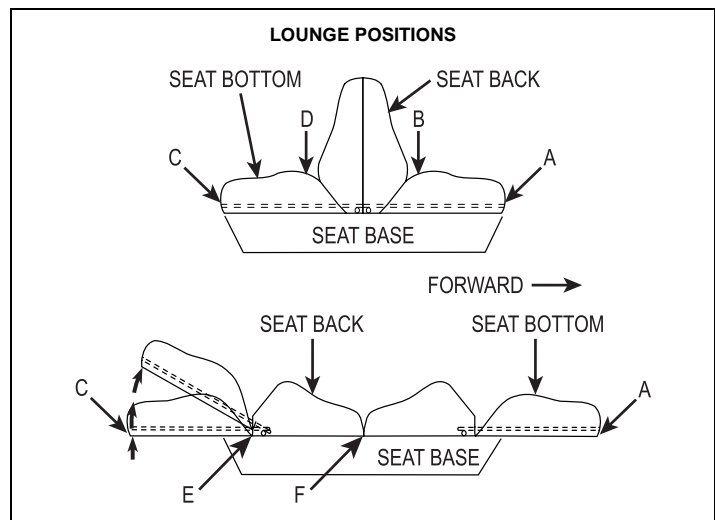

##### To adjust into the chaise lounge position:

1. Lift up on the forward or aft seat bottom at point (A or C) and push the seat bottom down into the locked position.
2. To lower the seat bottom, lift the seat at point (A or C). Drop the seat bottom flat while holding the seat down at point (E).

##### To return the seats to the operating position:

1. Lift the seat backs at point (F) and push down on the back edge of the seat bottom (B) and then seat bottom (D).
2. Push the seat bottoms towards the center of the seat until the seat backs are flush against each other and locked into place.

## Jump Seat To Sunlounge Conversion (If Equipped)

⚠ **DANGER!**



**PERSONAL SAFETY HAZARD! DO NOT** allow anyone to ride the aft sunlounge cushions while underway or anytime the engine is running.

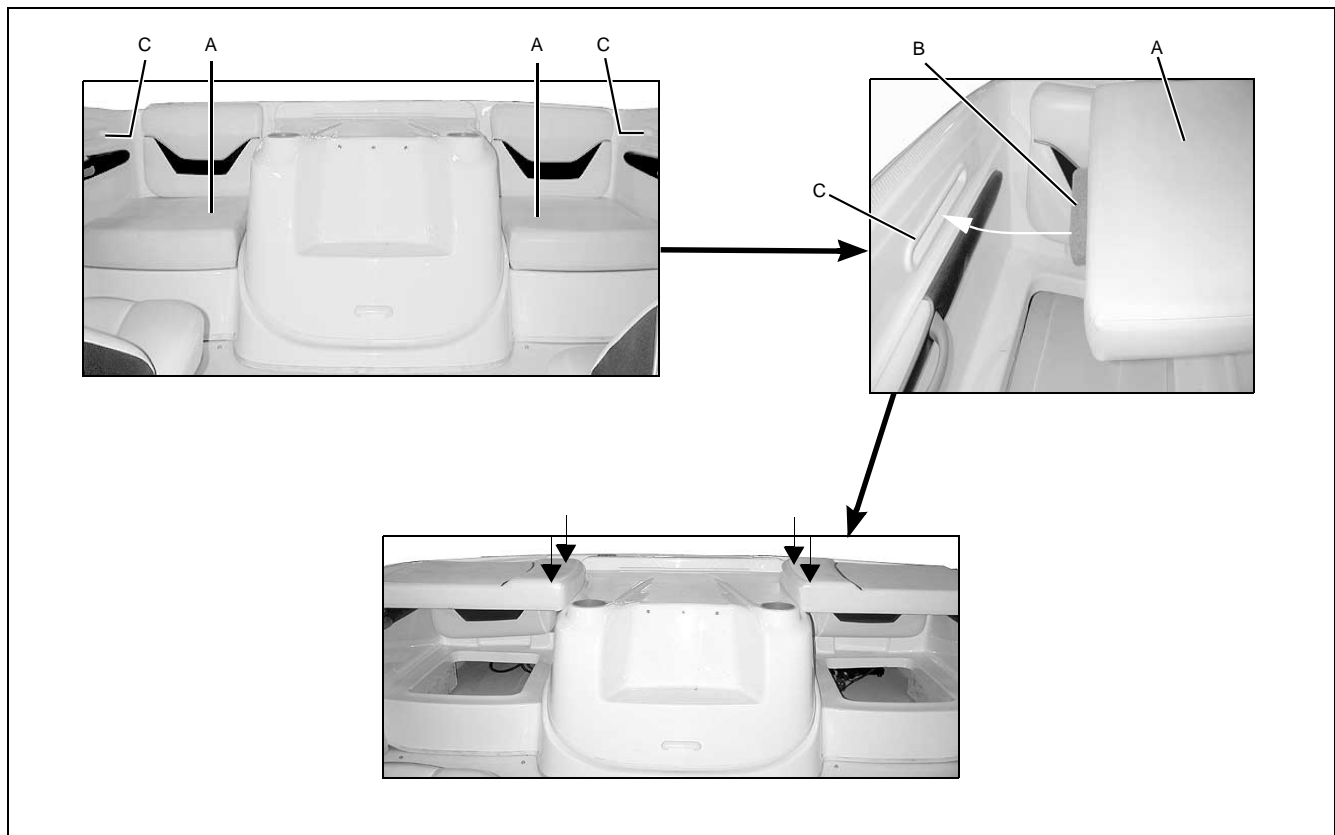

1. Remove the jump seats (A) by sliding them forward.
2. Slide the lounge support inserts (B) into the lounge support slots (C).
3. Press down firmly on the inboard side of each jump seat until they rest firmly on the motorbox ledges.

## Chapter 10: Lights

---

### Care and Maintenance

All of the lights installed on your boat are of top quality, but you should be aware that failure may periodically occur for a variety of reasons:

1. There may be a blown fuse - *replace the fuse.*
2. The bulb may be burned out - *carry spare bulbs for replacement.*
3. A wire may be damaged or may have come loose - *repair as required.*
4. The bulb base may be corroded - *clean the base and coat it with non-conductive electrical lubricant.*

### Navigation Lights



 <b>CAUTION!</b>
<b>Avoid the storage of gear where it would block navigation lights from view.</b>

Read and understand the navigation light section of *Sport Boat Owner's Manual*.



## Chapter 11: Electrical System

 **DANGER!**





**EXTREME FIRE, SHOCK & EXPLOSION HAZARD!**

- To minimize the risks of fire and explosion, NEVER install knife switches or other arcing devices in the fuel compartments.
- NEVER substitute automotive parts for marine parts. Electrical, ignition and fuel system parts were designed and manufactured to comply with rules and regulations that minimize risks of fire and explosion.
- DO NOT modify the electrical systems or relevant drawings.
- Have qualified personnel install batteries and/or perform electrical system maintenance.

 **WARNING!**





**FIRE & EXPLOSION HAZARD!**

- Visually and by smell (sniff test), check the engine and fuel compartments for fumes or accumulation of fuel.
- Minimize the danger of fire and explosion by not exposing the batteries to open flame or sparks. NEVER smoke anywhere near the batteries.

 **CAUTION!**

**SHOCK & ELECTRICAL SYSTEM DAMAGE HAZARD! NEVER disconnect the battery cables while the engine is running since it can cause damage to your boat's electrical system components.**

### NOTICE

Electrical connections are prone to corrosion. To reduce corrosion caused electrical problems, keep all electrical connections clean and apply a spray-on protectant that is designed to protect connections from corrosion.

## 12-Volt DC System

### **Battery**

The battery supplies electricity for lights, accessories, and engine starting.

The Electrical section of Chapter 8, in the *Sport Boat Owner's Manual*, provides battery, care and maintenance instructions.

### **Fuses and Circuit Breakers**

- Fuses for the engine and main accessory power are on the fuse block behind the dash.
- Some equipment may have secondary fuse protection at the unit, or at the battery.
- Electronics power is provided at the helm station.

### **Alternator**

The engine alternator will keep the battery properly charged when running at cruising speeds.

### **12-Volt Accessory Outlet**

 <b>CAUTION!</b>
<b>DO NOT use the 12-volt accessory outlet with a cigarette or cigar lighter. High temperatures may melt the outlet.</b>

- Your boat is equipped with a 12-volt accessory outlet at the helm.
- The outlet can be used with any 12-volt device which draws 15 amps or less.
- The 12-volt accessory outlet is protected by 10 amp fuse on the main fuse block behind the dash.

# Electrical Routings

## 185 & 205 Deck Electrical Harness

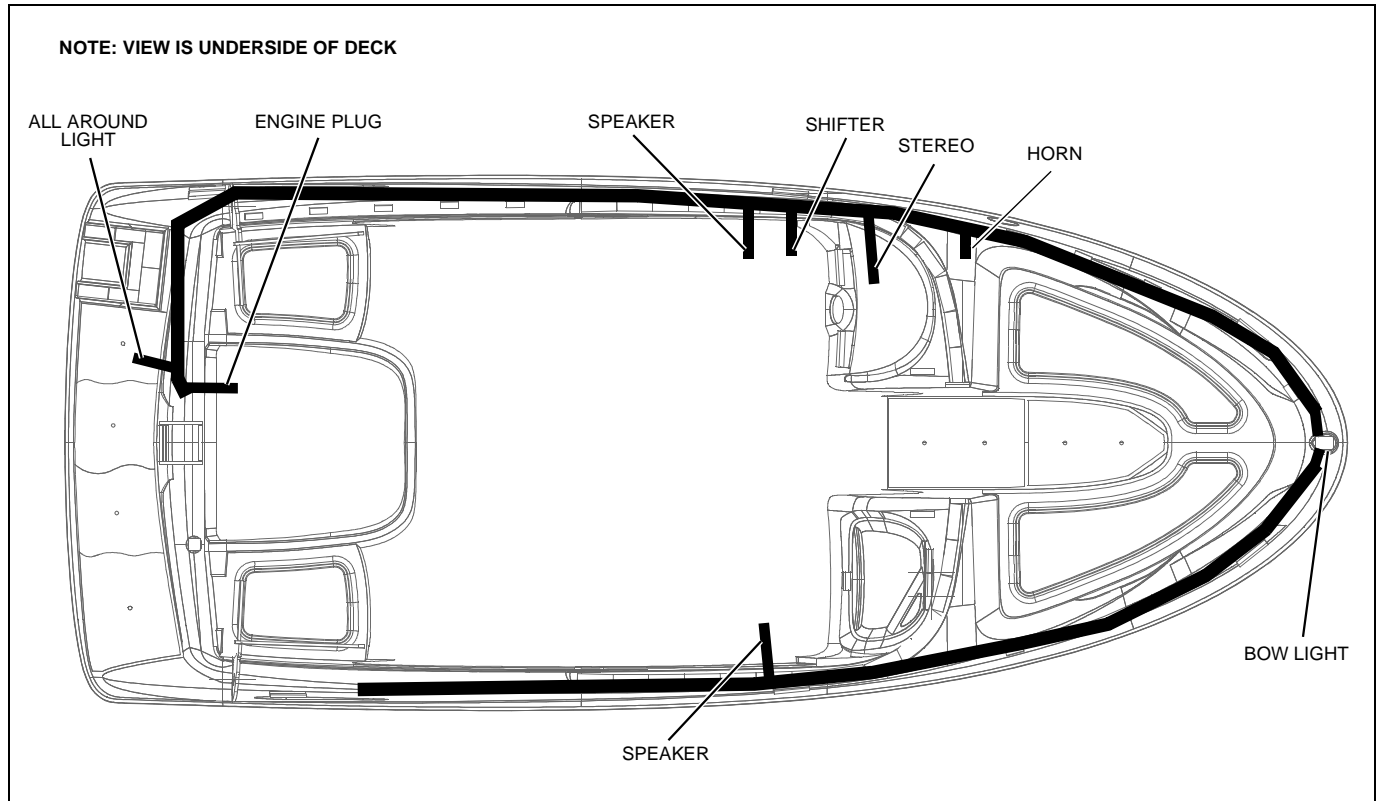

### Hull Electrical Harness

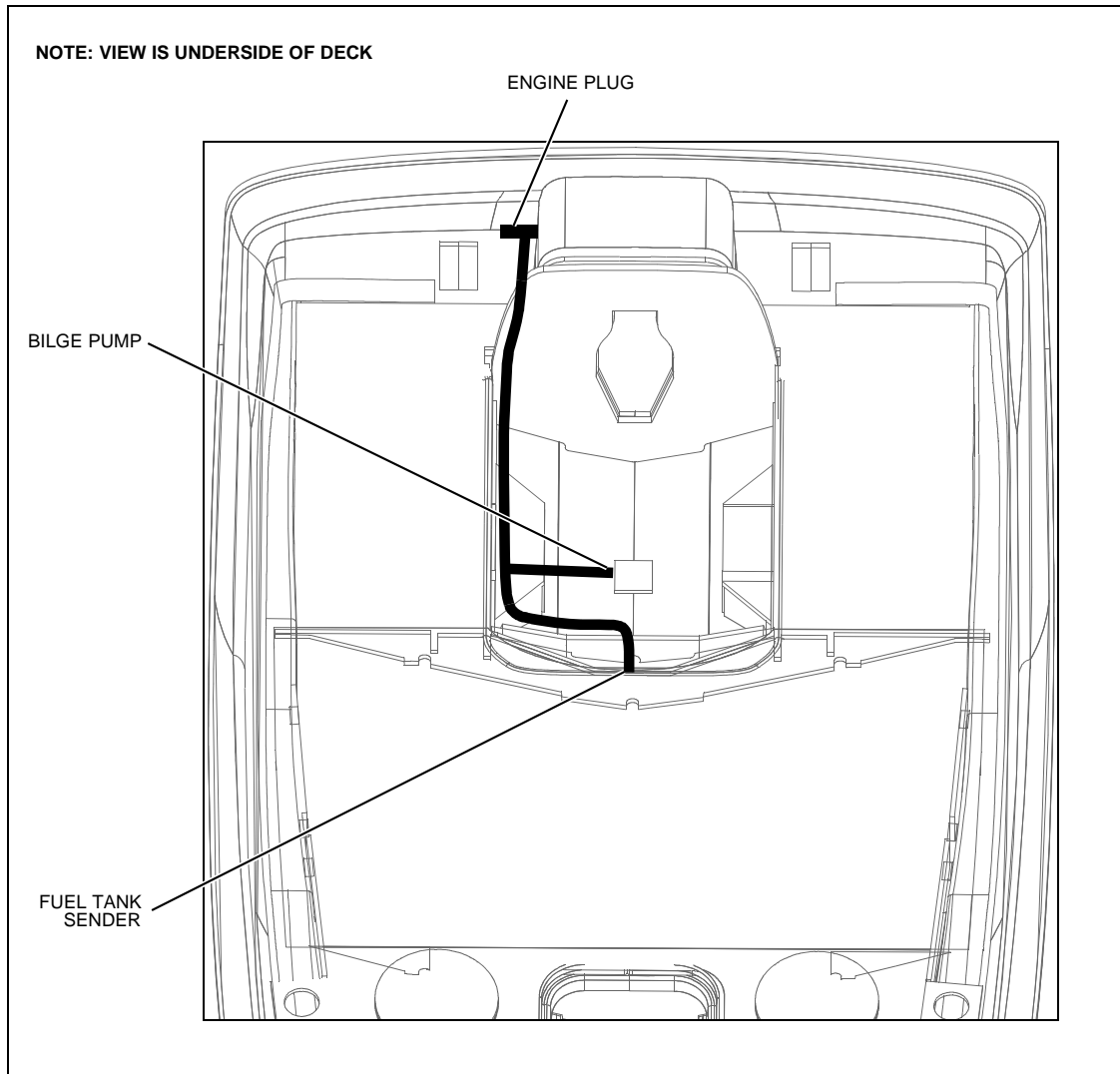

# Wire Diagram

## 185BBR & 205BR

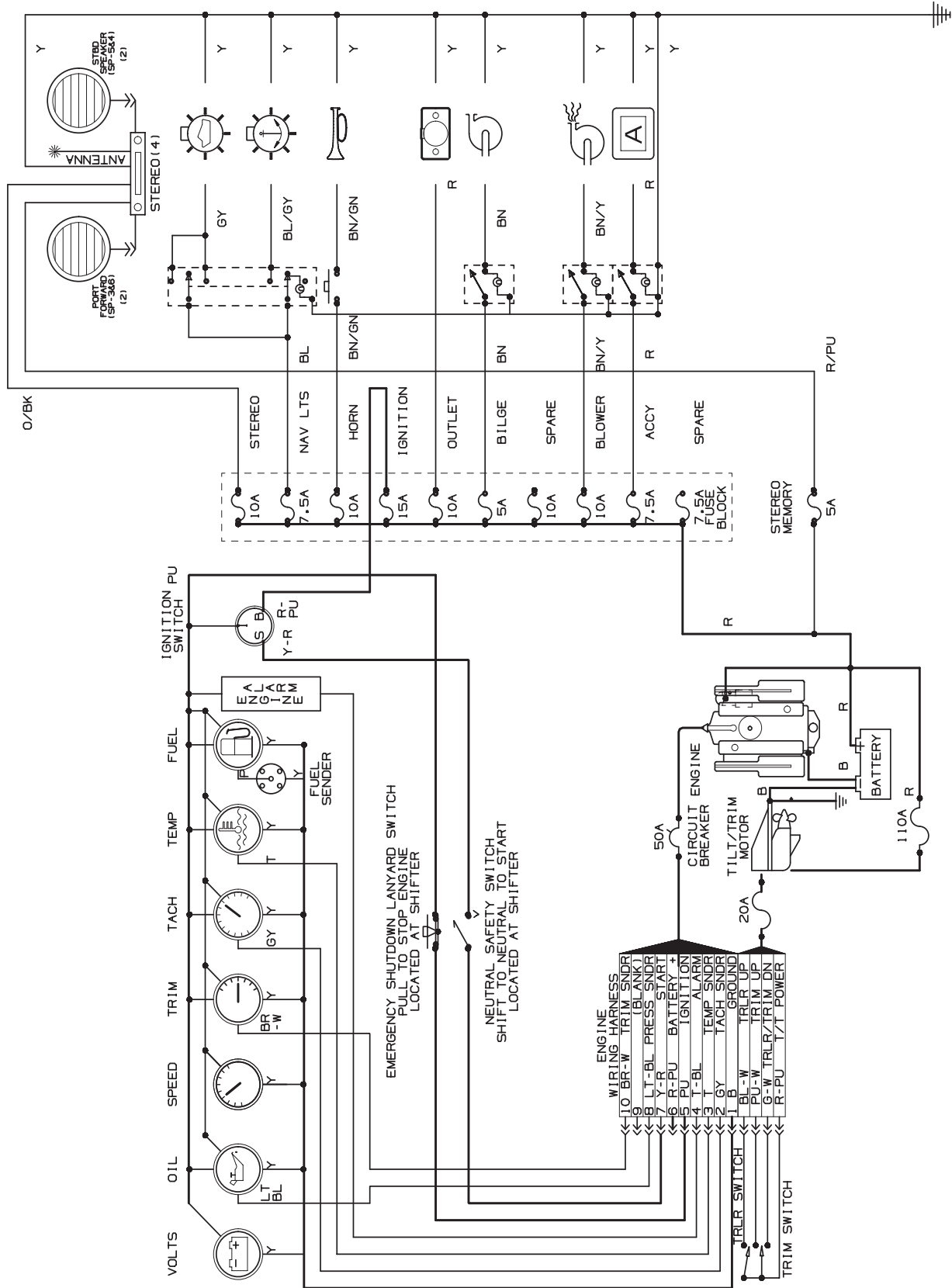

# Important Records

---

## Selling Dealer

\_\_\_\_\_  
Name Of Dealership

\_\_\_\_\_  
Address

\_\_\_\_\_  
Phone/FAX/E-mail

\_\_\_\_\_  
Sales Manager

\_\_\_\_\_  
Service Manager

## Engine

\_\_\_\_\_  
Manufacturer

\_\_\_\_\_  
Model Name/Number

\_\_\_\_\_  
Engine Serial Number

\_\_\_\_\_  
Oil Type/SAE

\_\_\_\_\_  
Quarts per Engine

\_\_\_\_\_  
Filter Type

## Propeller

\_\_\_\_\_  
Manufacturer

\_\_\_\_\_  
Pitch

\_\_\_\_\_  
Model Number

## Key Numbers

\_\_\_\_\_  
Ignition

\_\_\_\_\_  
Other

## Electronics

\_\_\_\_\_  
Manufacturer

\_\_\_\_\_  
Model Name/Number

\_\_\_\_\_  
Serial Number

\_\_\_\_\_  
Manufacturer

\_\_\_\_\_  
Model Name/Number

\_\_\_\_\_  
Serial Number

\_\_\_\_\_  
Manufacturer

\_\_\_\_\_  
Model Name/Number

\_\_\_\_\_  
Serial Number

\_\_\_\_\_  
Manufacturer

\_\_\_\_\_  
Model Name/Number

\_\_\_\_\_  
Serial Number

# Float Plan

---

Before going boating, fill out a copy of this float plan (or similar) and leave it with a **reliable** person whom you can depend on to contact the Coast Guard or other rescue organization, if you do not return as scheduled.

## Description of Boat

Registration/Documentation Number		
Length	Make	Type
Hull Color		Trim Color
Fuel Capacity	Engine Type	Number of Engines
Distinguishing Features		
Distinguishing Features		

## Operator of Boat

Full Name		
Male or Female	Age	Health
Address		
Address		
Phone/FAX/E-mail		
Operator's Experience		

## Persons on Board

Full Name		
Age	Health	Phone Number
Full Name		
Age	Health	Phone Number
Full Name		
Age	Health	Phone Number
Full Name		
Age	Health	Phone Number
Full Name		
Age	Health	Phone Number

### Survival Equipment

Marine Radio (Yes/No)	Type	Frequencies
Number of PFDs	Flares (Yes/No)	Mirror (yes or no)
Smoke Signals (Yes/No)	Flashlight (Yes/No)	Food (Yes/No)
Water (Yes/No)	Anchor (Yes/No)	Raft/Dinghy (Yes/No)
Paddles (Yes/No)	EPIRB (Yes/No)	Other
Other	Other	Other

### Vehicle Description

Make	Model
Color	License Number
Where is the Vehicle Parked?	

### Trip Expectations

Departing From	
Departure Date	Departure Time
Stopover 1	
Arrive No Later Than: Date	Arrive No Later Than: Time
Stopover 2	
Arrive No Later Than: Date	Arrive No Later Than: Time
Stopover 2	
Arrive No Later Than: Date	Arrive No Later Than: Time
Stopover 2	
Arrive No Later Than: Date	Arrive No Later Than: Time
Stopover 2	
Arrive No Later Than: Date	Arrive No Later Than: Time
Stopover 2	
Arrive No Later Than: Date	Arrive No Later Than: Time
Final Destination Port (If Different Than Home Port)	
Arrive No Later Than: Date	Arrive No Later Than: Time

**If not returned by the date and time listed above, call the Coast Guard or other local authority.**

Coast Guard Phone Number
Local Authority Phone Number









**Part Number 1747218**

**Bayliner • P.O. Box 9029 • Everett, WA 98206 • 360-435-5571**