

BAYLINER®

160/170/180/190 Bowriders

Owner's Manual *Supplement*

Engine Serial Number: _____

Hull Identification Number: _____

Hull Identification Number

The Hull Identification Number (HIN) will be located either on the starboard side of the transom or on the aft, starboard side of the gunwale and is your boat's most important identifying factor.

Record the HIN (and the engine serial number) in the space provided above.

This number must be included in all correspondence and orders.

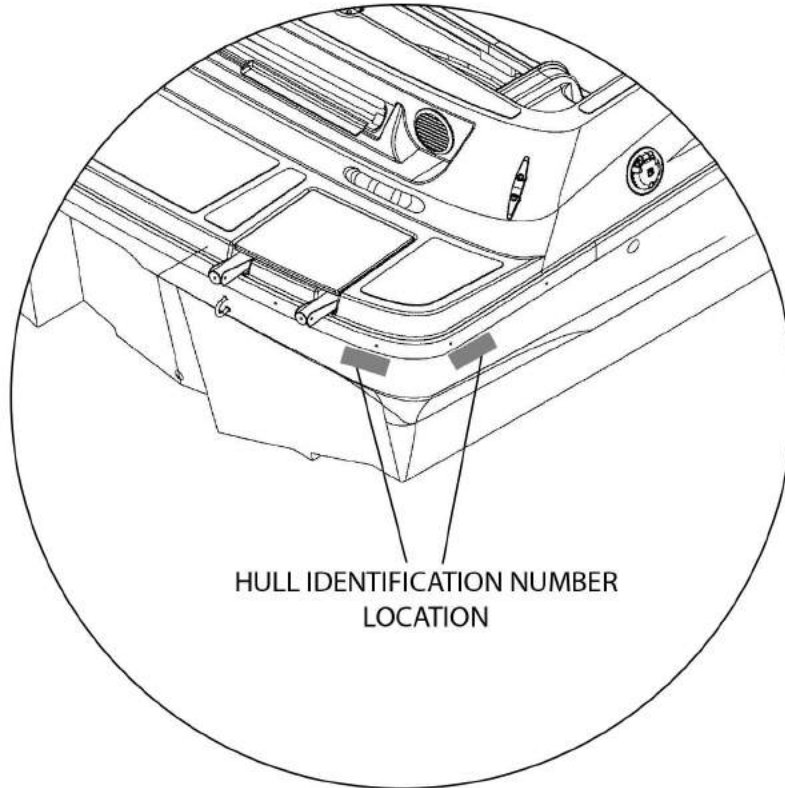

160/170/180/190 Bowriders

© 2012 Bayliner Technical Publications. All rights reserved.

No part of this publication may be reproduced, stored in any retrieval system, or transmitted in any form by any means, electronic, mechanical, photocopying, recording or otherwise, without prior written permission of Bayliner.
Printed in the United States of America.

General Notes

The material in this document is for information only and is subject to change without notice. While reasonable efforts have been made in the preparation of this document to assure its accuracy, Bayliner assumes no liability resulting from errors or omissions in this document, or from the use of information contained herein.

Due to our commitment to product improvement, Bayliner reserves the right to make changes in the product design, specifications, and equipment at any time without notice or obligation. Illustrations and/or photos may show optional equipment.

All Bayliner products meet or exceed USCG (United States Coast Guard) and/or NMMA (National Marine Manufacturers Association) construction standards. Manufactured with 1,1,1 Trichloroethane, a substance which harms public health and environment during the manufacturing process by destroying ozone in the upper atmosphere.

Proprietary Rights

This document discloses subject matter in which Bayliner has proprietary rights. The information and design disclosed herein were originated by and are the property of Bayliner. Neither receipt nor possession thereof confers or transfers any right to reproduce, copy, alter or disclose the document or any part thereof, any information contained therein, or to construct boats or any item from it, except by written permission from or written agreement with Bayliner. This document is to be returned upon request to Bayliner.

Contents

Chapter 1: Welcome Aboard!	1
Dimensions and Tank Capacities	1
Dealer Service	1
Warranty Information	2
Boating Experience	2
Engine, Accessory Guidelines and Literature	3
Qualified Maintenance	4
Special Care for Moored Boats	4
Safety Standards	5
Carbon Monoxide (CO)	6
<i>CO Facts</i>	6
<i>Factors that Increase the Effects of CO Poisoning</i>	6
<i>Where and How CO Can Accumulate</i>	7
<i>How to Protect Yourself and Others From CO</i>	7
<i>CO Checklists</i>	8
<i>More Information</i>	8
Warning Labels	9
Helm Warning Labels	12
Chapter 2: Locations	13
Exterior Views	13
<i>Hull Views</i>	13
<i>Deck Views</i>	14
<i>Helm Views</i>	17
Component Locations	19
<i>Bilge Components</i>	19
<i>Battery</i>	20
<i>Port Hull Components</i>	20
Chapter 3: Propulsion and Related Systems	21
Engine	21
Gasoline Fuel System	21
Fuel System Layouts	22
Chapter 4: Controls and Gauges	24
Steering	24
Shift/Throttle Controls	24
Power Trim and Tilt	24
Gauges	24
Chapter 5: Navigation Equipment	25
Depth Finder (If Equipped)	25
Chapter 6: Plumbing	26
Bilge Pump	26
<i>Bilge Pump Testing</i>	27
Drain System	27
<i>Deck Drains</i>	27
Livewell System 170/180/190 BR	28

Chapter 7: Deck Equipment	29
Cleats and Bow/Stern Eyes	29
Ski-Tow Pylon (If Equipped).....	29
Ski-Tow Tower (If Equipped).....	30
Canvas (If Equipped).....	31
<i>Bimini Top: Option A (If Equipped)</i>	31
<i>Bimini Top: Option B (If Equipped)</i>	31
<i>Convertible Top (If Equipped)</i>	32
<i>Bow Cover (If Equipped)</i>	33
<i>Canvas Care</i>	34
Chapter 8: Entertainment System.....	35
Audio System (If Equipped)	35
Chapter 9: Convertible Seats	36
Sleeper Seats (If Equipped)	36
<i>Operating Positions</i>	36
<i>Lounge Positions</i>	36
Removable Fishing Seat (If Equipped).....	37
Chapter 10: Lights	38
Care and Maintenance.....	38
Interior and Exterior Lights	38
Navigation Lights.....	38
Chapter 11: Electrical System.....	39
12-Volt DC System	40
<i>Battery</i>	40
<i>Fuses and Circuit Breakers</i>	40
<i>12-Volt DC Accessory Outlet (If Equipped)</i>	40
<i>Alternator</i>	40
<i>DC Wiring Schematics</i>	41
Electrical Routings.....	47
<i>12-Volt DC Deck Harnesses</i>	47
<i>12-Volt DC Hull Harnesses</i>	51
<i>Battery Cable Routings</i>	53

Hazard Boxes and Symbols

The hazard boxes and symbols shown below are used throughout this supplement to call attention to potentially dangerous situations which could lead to either personal injury or product damage. Read all warnings carefully and follow all safety instructions.

 **DANGER**

DANGER - Immediate hazards which WILL result in severe personal injury or death if the warning is ignored.

 **WARNING**

WARNING - Hazards or unsafe practices which MAY result in severe personal injury or death if the warning is ignored.

 **CAUTION**

CAUTION - Hazards or unsafe practices which COULD result in minor injury, product or property damage if the warning is ignored.

NOTICE

Information which is important to proper operation or maintenance, but is not hazard related.

Chapter 1: Welcome Aboard!

This *Owner's Manual Supplement* provides specific information about your boat that is not covered in the *Sport Boat Owner's Manual*.

- The *Sport Boat Owner's Manual* contains general information about safe operating practices, general boating regulations, and general maintenance techniques.
- Before using your boat, study this *Owner's Manual Supplement*, the *Sport Boat Owner's Manual*, and all engine and accessory literature carefully. If similar instructions are found in more than one manual, always refer to the specific manufacturer's manual (such as the engine manual) for the most complete and accurate information.
- Keep this *Owner's Manual Supplement* and the *Sport Boat Owner's Manual* on your boat in a secure, yet readily available place.

Dimensions and Tank Capacities

160BR

Overall Length	Bridge Clearance	Bridge Clearance with Tower	Beam	Draft (Hull)	Draft (Maximum)	Fuel Capacity
16' 2"	3' 5"	N/A	7' 2"	1' 2"	2' 7"	18 Gallons

170BR

Overall Length	Bridge Clearance	Bridge Clearance with Tower	Beam	Draft (Hull)	Draft (Maximum)	Fuel Capacity
17' 5"	3' 2"	6' 7"	7'	1' 6"	2' 11"	21 Gallons

180BR

Overall Length	Bridge Clearance	Bridge Clearance with Tower	Beam	Draft (Hull)	Draft (Maximum)	Fuel Capacity
18'	3' 5"	7' 2"	7' 8"	1' 8"	2' 10"	28 Gallons

190BR

Overall Length	Bridge Clearance	Bridge Clearance with Tower	Beam	Draft (Hull)	Draft (Maximum)	Fuel Capacity
19' 5"	3' 7"	7' 5"	7' 11"	1' 6"	3'	32 Gallons

Dealer Service

Your dealer is your key to service.

- Ask your dealer to explain all systems before taking delivery of your boat.
- Contact your dealer if you have any problems with your new boat.
- If your dealer cannot help, call our customer service hotline: 865-971-6311.
- Bayliner advises that all rigging, installation and prep work on any Bayliner product be done by an authorized dealer at the authorized dealer's location.
- Buy replacement parts from any authorized Bayliner dealer.
- You can access additional information by logging on to <http://www.bayliner.com>.

Warranty Information

- Bayliner offers a Limited Warranty on each new Bayliner purchased through an authorized Bayliner dealer.
- A copy of the Limited Warranty was included in your owner's packet.
- If you did not get a copy of the Limited Warranty, please contact your Bayliner dealer or call 865-971-6311 for a copy.

Boating Experience

 **WARNING**

CONTROL HAZARD!

An experienced operator **MUST** be in control of your boat at ALL times.
Do **NOT** operate your boat while under the influence of alcohol or drugs.

If this is your first boat or if you are changing to a type of boat you are not familiar with, for your own comfort and safety, get handling and operating experience before assuming command of your boat.

Take one of the boating safety classes offered by the United States Power Squadrons® or the United States Coast Guard Auxiliary. For more course information, including dates and locations of upcoming classes, contact the organizations directly:

- U.S. Power Squadrons: 1-888-FOR-USPS (1-888-367-8777) or www.usps.org
- U.S. Coast Guard Auxiliary: 1-800-368-5647 or www.cgaux.org
- In Canada, for CPS courses: 1-888-CPS-BOAT

Outside the United States, your selling dealer, national sailing federation, or local boat club can advise you of local sea schools or competent instructors.

Engine, Accessory Guidelines and Literature

NOTICE

- Before starting or working on your engine(s), read the engine manual.
- Before using the accessories on your boat, read the accessory manuals.
- Before storing your boat, refer to your engine and accessory manuals for storage/winterization instructions.

NOTICE

Certain modifications to your boat will result in cancellation of your warranty protection. Always check with your dealer before making any modifications.

- Your boat's engine and accessories were selected to provide optimum performance and service.
- Installing a different engine or adding accessories may affect your boat's running trim.
- If you choose to install a different engine or add accessories that may affect your boat's running trim, have a trained marine technician perform a safety inspection and handling test before using your boat again.
- The engine and accessories on your boat have their own manuals. Read these manuals before using the engines and accessories.

Unless noted otherwise, all engine and accessory literature referred to in this supplement is included in your owner's packet.

While the topics listed below may be included in this supplement and in the *Sport Boat Owner's Manual*, always refer to the engine manual first for specific information on these important subjects:

- | | |
|--------------------------------|--------------------------------|
| • Engine Break-in Procedure | • Fuel and Oil Recommendations |
| • Engine Starting and Stopping | • Engine Maintenance |
| • Gear Shifting | • Engine Storage/Winterization |

Propeller



CAUTION

ENGINE DAMAGE HAZARD!

The factory standard propeller may not be the best for your particular boat and load conditions. Refer to the engine manual RPM ratings. The engine should reach, but not exceed its full rated RPM when full-throttle is applied. Immediately contact your local Bayliner dealer if:

- The engine cannot reach its full rated RPM when full-throttle is applied
- The engine exceeds its full rated RPM when full-throttle is applied

- Keep the propeller in good repair and at the correct pitch for your particular situation.
- A slightly bent or nicked propeller will adversely affect the performance of your boat.

Qualified Maintenance



WARNING

To maintain the safety of your boat, allow **ONLY** trained personnel to work on, or change, in any way, the following:

- Steering system
- Propulsion system
- Engine control system
- Fuel system
- Environmental control system
- Electrical system
- Navigation system

Failure to maintain your boat's systems (listed in the warning above) as designed could violate the laws in your jurisdiction and could expose yourself and others to the danger of bodily injury or accidental death.

Follow the maintenance instructions in:

- This *Owner's Manual Supplement*
- The *Sport Boat Owner's Manual*
- The engine owner's manual
- All accessory literature

Special Care for Moored Boats

NOTICE

- To help seal the hull bottom and reduce the chance of gel coat blistering while your boat is moored, apply an epoxy barrier coating.
- The barrier coating should be covered with several coats of anti-fouling paint.
- Many states regulate the chemical content of bottom paints in order to meet environmental standards. Check with your local dealer about recommended bottom paints, and about the laws in effect in your area.

- Whether moored in saltwater or freshwater, your boat will collect marine growth on its hull bottom.
- This will detract from your boat's beauty, greatly affect its performance, and may damage the gel coat.
- Periodically haul your boat out of the water and scrub the hull bottom with a bristle brush and a solution of soap and water.

Safety Standards

DANGER

FALLING and ROTATING PROPELLER HAZARD!

- NEVER allow anyone to ride on parts of your boat not designed for such use.
- Sitting on seat-backs, lounging on the forward deck, bow riding, gunwale riding or occupying the transom platform while underway is especially hazardous and WILL cause personal injury or death.

DANGER

FALLING, ROTATING PROPELLER and CARBON MONOXIDE POISONING HAZARD!

- NEVER allow anyone to occupy, or hang from, the back deck or transom platform while the engine is running.
- Teak surfing, dragging or water skiing within 20 feet of a moving watercraft can be fatal.

DANGER

PERSONAL SAFETY HAZARD!

- ALWAYS secure the anchor and other loose objects BEFORE getting underway.
- The anchor and other items that are not properly secured can come loose when your boat is moving and cause personal injury or death.

WARNING

A wide variety of components used on this vessel contain or emit chemicals known to the State of California to cause cancer and birth defects and other reproductive harm.

Examples include:

- Engine and generator exhaust
- Engine and generator fuel, and other liquids such as coolants and oil, and especially, used motor oil
- Cooking fuels
- Cleaners, paints, and substances used for vessel repair
- Waste materials that result from wear of vessel components
- Lead from battery terminals and other sources such as ballast or fishing sinkers

To Avoid Harm:

- Keep away from engine, generator, and cooking fuel exhaust fumes.
- Wash exposed skin thoroughly with soap and water after handling the substances above.

- Your boat's mechanical and electrical systems were designed to meet safety standards in effect at the time it was built.
- Some of these standards were mandated by law, and all of them were designed to insure your safety and the safety of other people, vessels and property.

Read this supplement, the *Sport Boat Owner's Manual*, the engine owner's manual, and all accessory instructions for important safety standards and hazard information.

Carbon Monoxide (CO)

DANGER

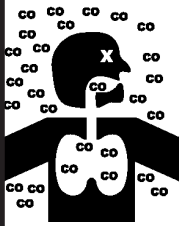

- Carbon monoxide gas (CO) is colorless, odorless, tasteless, and extremely dangerous.
- ALL engines, generators, and fuel burning appliances produce CO as exhaust.
- Prolonged exposure to low concentrations or very quick exposure to high concentrations WILL cause BRAIN DAMAGE or DEATH.
- Teak surfing, dragging, or water skiing within 20 feet of a moving watercraft can be fatal.

CO Facts

- CO poisoning causes a significant number of boating deaths each year.
- Called the "silent killer", CO is an extremely toxic, colorless, odorless and tasteless gas.
- CO can harm or even kill you inside or outside your boat.
- CO can affect you whether you're underway, moored, or anchored.
- CO symptoms are similar to seasickness or alcohol intoxication.
- CO can make you sick in seconds. In high enough concentrations, even a few breaths can be fatal.
- Breathing CO blocks the ability of your blood to carry oxygen.
- The effects are cumulative. Even low levels of exposure can result in injury or death.

Factors that Increase the Effects of CO Poisoning

- Age
- Smokers or people exposed to high concentrations of cigarette smoke
- Consumption of alcohol
- Lung disorders
- Heart problems
- Pregnancy

Where and How CO Can Accumulate

Stationary conditions that increase CO accumulations include:

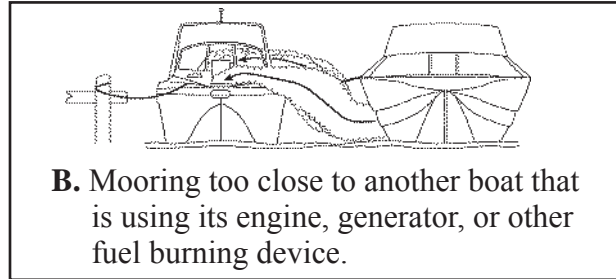
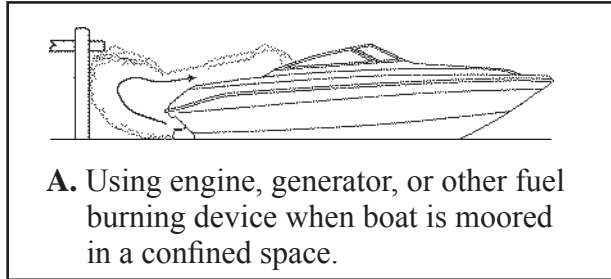

To correct stationary situations A and/or B:

- Close all windows, portlights and hatches.
- If possible, move your boat away from source of CO.

Running conditions that increase CO accumulations include:

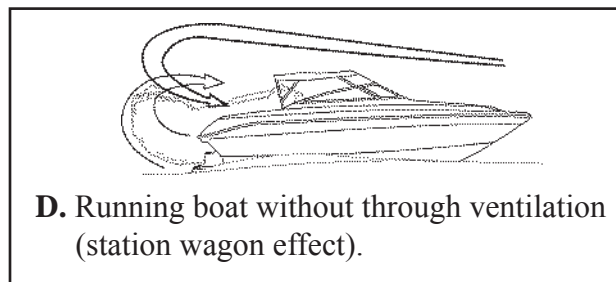
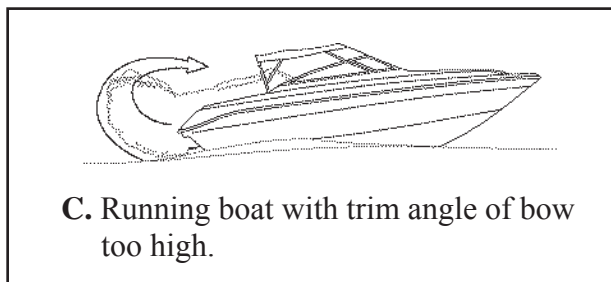

To correct running situations C and/or D:

- Trim bow down.
- Open windows and canvas.
- When possible, run boat so that prevailing winds help dissipate exhaust.

How to Protect Yourself and Others From CO

- Know where and how CO may accumulate in and around your boat (see above).
- Always maintain fresh air circulation throughout your boat.
- Know where your engine and generator exhaust outlets are located and keep everyone away from these areas.
- Never sit on, or hang onto, the back deck or transom platform while the engine is running.
- Never enter the areas under transom platforms where exhaust outlets are located.
- Although CO can be present without the smell of exhaust fumes, if exhaust fumes are detected on your boat, take immediate action to dissipate these fumes.
- Treat symptoms of seasickness as possible CO poisoning. Get the person into fresh air immediately. Seek medical attention—unless you're sure it's not CO.
- **Install and maintain CO monitors inside your boat.** Never ignore any alarm. Replace monitors as recommended by the monitor manufacturer.
- Follow the checklists provided on the next page.
- Get a Vessel Safety Check.

For information on how to get a free VESSEL SAFETY CHECK, visit www.vesselsafetycheck.org or contact your local U.S. Coast Guard Auxiliary or U.S. Power Squadrons:

- U.S. Coast Guard Auxiliary: 1-800-368-5647 or www.cgaux.org
- U.S. Power Squadrons: 1-888-FOR-USPS (1-888-367-8777) or www.usps.org

CO Checklists

Trip Checklist

- Make sure you know where the exhaust outlets are located on your boat.
- Educate all passengers about the symptoms of CO poisoning and where CO may accumulate.
- When docked, or rafted with another boat, be aware of exhaust emissions from the other boat.
- Listen for any change in exhaust sound, which could mean an exhaust component failure.
- Test the operation of each CO monitor by pressing the test button.

Monthly Checklist

- Make sure all exhaust clamps are in place and secure.
- Look for exhaust leaking from exhaust system components. Signs include rust and/or black streaking, water leaks, or corroded or cracked fittings.
- Inspect rubber exhaust hoses for burned, cracked, or deteriorated sections. All rubber hoses should be pliable and free of kinks.

Annual Checklist

Have a Trained Marine Technician:

- Replace exhaust hoses if cracking, charring, or deterioration is found.
- Ensure that your engines and generators are properly tuned, and well maintained.
- Inspect each water pump impeller and the water pump housing. Replace if worn. Make sure cooling systems are in working condition.
- Inspect all metallic exhaust components for cracking, rusting, leaking, or loosening. Make sure they check the cylinder head gasket, exhaust manifold, water injection elbow, and the threaded adapter nipple between the manifold and the elbow.
- Clean, inspect, and confirm proper operation of the generator cooling water anti-siphon valve (if equipped).

More Information

For more information about preventing carbon monoxide poisoning on recreational boats and other boating safety tips, contact:

United States Coast Guard
Office of Boating Safety (G-OPB-3)
2100 Second Street SW
Washington, DC 20593
www.uscgboating.org
1-800-368-5647

National Marine Manufacturers
Association (NMMA)
200 East Randolph Drive
Suite 5100
Chicago, IL 60601-9301
www.nmma.org
312-946-6200

American Boat & Yacht
Council, Inc. (ABYC)
613 Third Street
Suite 10
Annapolis, MD 21403
www.abycinc.org
410-990-4460

Warning Labels

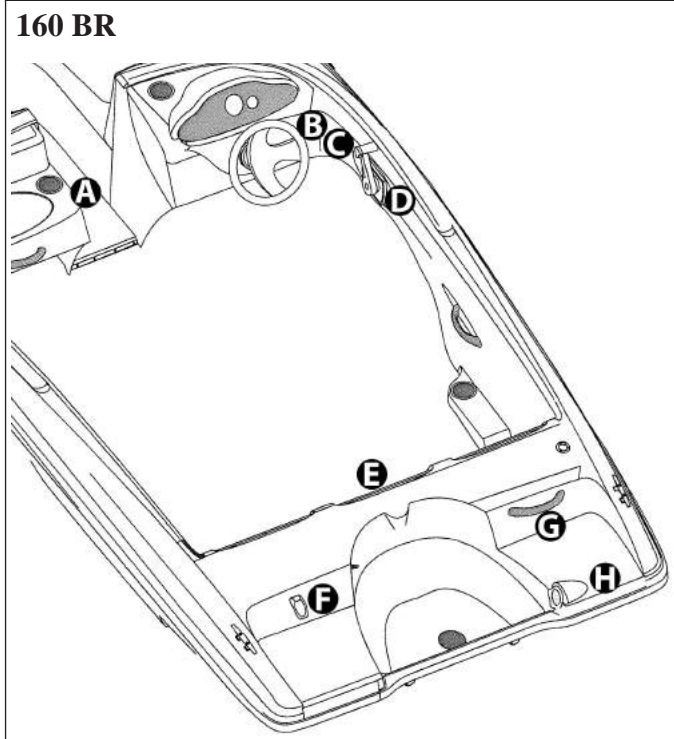

A THE UNITED STATES COAST GUARD (USCG) RECOMMENDS THAT ALL OCCUPANTS WEAR APPROVED PERSONAL FLOATION DEVICES (PFDs).

⚠ DANGER
PROPELLER(S) MAY CAUSE SERIOUS INJURY OR DEATH
 Shut-off engine(s) when near swimmers, prior to using sunpads, swim platform, or boarding ladder.

⚠ WARNING
AVOID COLLISIONS-

- Maintain lookout as required by the "Rules of the Road"
- Visibility can be limited by high boat trim angles, persons, gear, weather and atmospheric conditions.
- At all times proceed at a safe speed, in order to take proper and effective action to avoid hazardous conditions.

SUCH ISSUES ARE UNDER THE CONTROL OF THE OPERATOR!
AVOID SKI LINES AND TOW ROPES-
 Ski lines and tow ropes can backlash into the cockpit when released.

⚠ CAUTION
AVOID INHALATION OF TOXIC FUMES-
 If fire extinguishing system discharge occurs, ventilate space before entering.

⚠ WARNING **F**

Gasoline vapors are explosive! Avoid serious injury or death from fire or explosion, resulting from leaking fuel.

Inspect system for leaks at least once a year. The use of fuels containing ethanol higher than 10% (E-10) can damage your engine or fuel system and will void the warranty. Never use (E-85).

Open flame appliances can ignite gasoline vapors causing death or injuries from the fire or explosion. Turn off all open flame appliances when refueling.

⚠ WARNING **B**

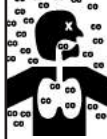

Carbon monoxide (CO) can cause brain damage or death. Engine and generator exhaust contains odorless and colorless carbon monoxide gas. Signs of carbon monoxide poisoning include nausea, headache, dizziness, drowsiness, and lack of consciousness. Get fresh air if anyone shows signs of carbon monoxide poisoning. See Owner's Manual for information regarding carbon monoxide poisoning.

⚠ DANGER **G**



Carbon monoxide (CO) can cause brain damage or death. Engine and generator exhaust contains odorless and colorless carbon monoxide gas. Carbon monoxide will be around the back of the boat when engines or generators are running. Move to fresh air, if you feel nausea, headache, dizziness, or drowsiness.

C

U.S. COAST GUARD
MAXIMUM CAPACITIES
5 PERSONS OR 650 LBS
 1260 LBS. PERSONS, MOTOR GEAR
 100 H.P. MOTOR

THIS BOAT COMPLIES WITH U.S. COAST GUARD SAFETY STANDARDS IN EFFECT ON THE DATE OF CERTIFICATION
 MANUFACTURER - BAYLINER MARINE LAKE FOREST, IL
 MODEL: 160 BR
 DESIGN COMPLIANCE WITH NMMA REQUIREMENTS IS VERIFIED.
 MANUFACTURER RESPONSIBLE FOR PRODUCTION CONTROL.

NMMA CERTIFIED
by **AWC** standard
 NATIONAL MARINE MANUFACTURERS ASSN

⚠ DANGER **H**

TO AVOID RISK OF SERIOUS INJURY OR DEATH SHUT OFF ENGINE WHEN NEAR SWIMMERS OR PRIOR TO USING SWIM PLATFORM AND BOARDING LADDER

D

MEETS U.S. EPA EVAP STANDARDS USING CERTIFIED COMPONENTS
 Bayliner Marine, Lake Forest, IL

⚠ WARNING **E**

LEAKING FUEL IS A FIRE AND EXPLOSION HAZARD. INSPECT SYSTEM REGULARLY. EXAMINE FUEL TANKS FOR LEAKS OR CORROSION AT LEAST ANNUALLY.

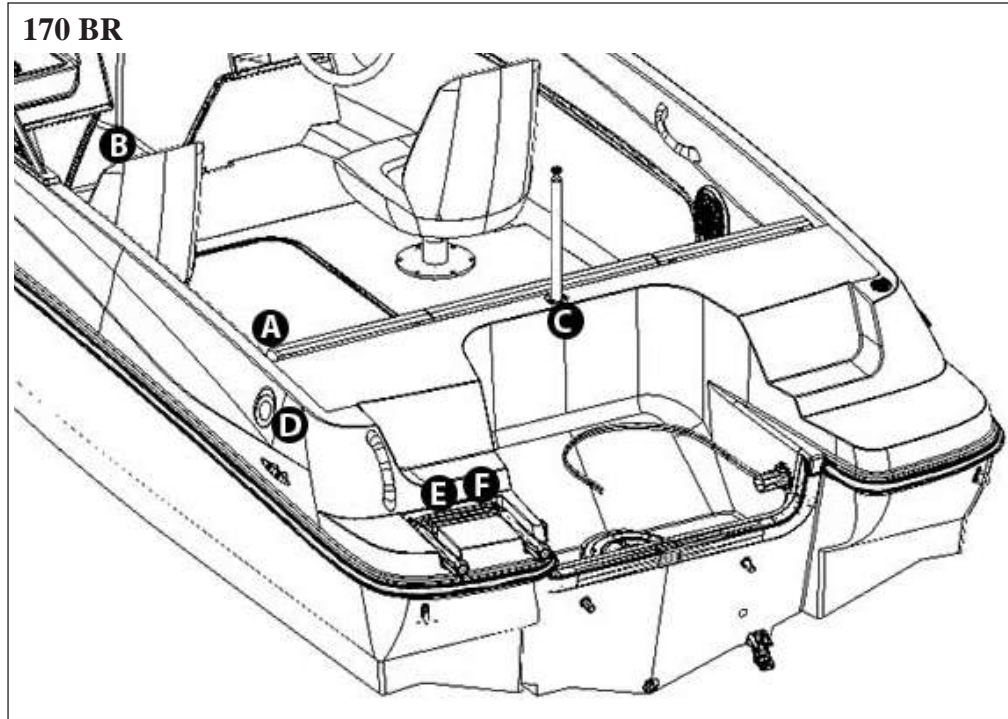

A **⚠ WARNING**
 LEAKING FUEL IS A FIRE AND EXPLOSION HAZARD. INSPECT SYSTEM REGULARLY. EXAMINE FUEL TANKS FOR LEAKS OR CORROSION AT LEAST ANNUALLY.

B **⚠ CAUTION**
 IF SWITCH IS TURNED OFF WHILE ENGINE IS RUNNING ALTERNATOR WILL BE DAMAGED.

C **⚠ WARNING**
 USE CAUTION WITH SKIER IN TOW AS TOW ROPE MAY BACKLASH INTO COCKPIT WHEN RELEASED

D **⚠ WARNING**
 Gasoline vapors are explosive! Avoid serious injury or death from fire or explosion, resulting from leaking fuel.
 Inspect system for leaks at least once a year. The use of fuels containing ethanol higher than 10% (E-10) can damage your engine or fuel system and will void the warranty. Never use (E-85).
 Open flame appliances can ignite gasoline vapors causing death or injuries from the fire or explosion. Turn off all open flame appliances when refueling.

E **⚠ DANGER**
 TO AVOID RISK OF SERIOUS INJURY OR DEATH SHUT OFF ENGINE WHEN NEAR SWIMMERS OR PRIOR TO USING SWIM PLATFORM AND BOARDING LADDER

F **⚠ DANGER**

 Carbon monoxide (CO) can cause brain damage or death.
 Engine and generator exhaust contains odorless and colorless carbon monoxide gas.
 Carbon monoxide will be around the back of the boat when engines or generators are running.
 Move to fresh air, if you feel nausea, headache, dizziness, or drowsiness.

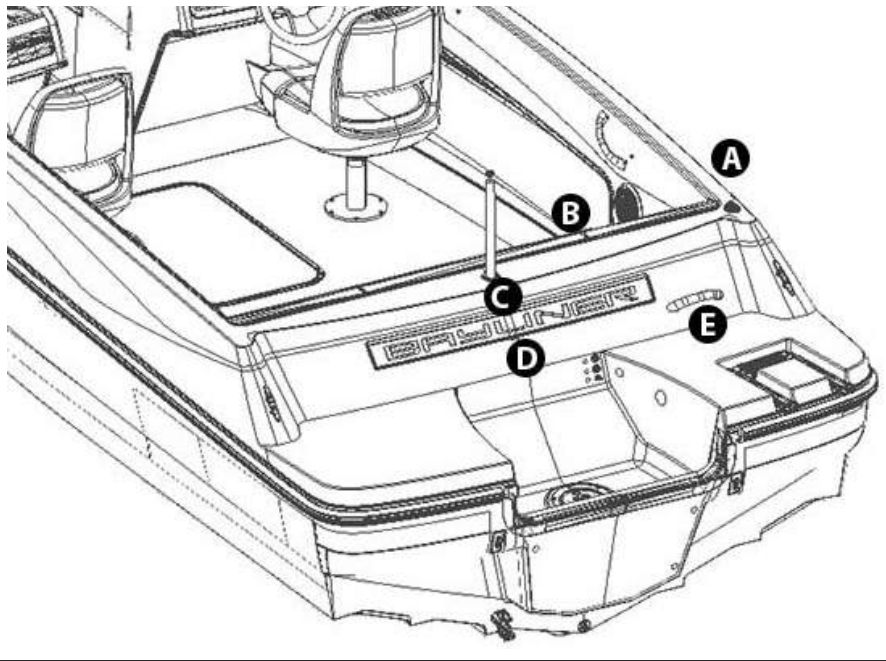
180/190 BR



A **⚠ WARNING**

Gasoline vapors are explosive!
Avoid serious injury or death from fire or explosion, resulting from leaking fuel.

Inspect system for leaks at least once a year. The use of fuels containing ethanol higher than 10% (E-10) can damage your engine or fuel system and will void the warranty. Never use (E-85). Open flame appliances can ignite gasoline vapors causing death or injuries from the fire or explosion. Turn off all open flame appliances when refueling.

E **⚠ DANGER**

TO AVOID RISK OF SERIOUS INJURY OR DEATH SHUT OFF ENGINE WHEN NEAR SWIMMERS OR PRIOR TO USING SWIM PLATFORM AND BOARDING LADDER

B **⚠ WARNING**

LEAKING FUEL IS A FIRE AND EXPLOSION HAZARD. INSPECT SYSTEM REGULARLY. EXAMINE FUEL TANKS FOR LEAKS OR CORROSION AT LEAST ANNUALLY.

C **⚠ WARNING**

USE CAUTION WITH SKIER IN TOW AS TOW ROPE MAY BACKLASH INTO COCKPIT WHEN RELEASED

D **⚠ DANGER**



Carbon monoxide (CO) can cause brain damage or death.
Engine and generator exhaust contains odorless and colorless carbon monoxide gas.
Carbon monoxide will be around the back of the boat when engines or generators are running.
Move to fresh air, if you feel nausea, headache, dizziness, or drowsiness.

Helm Warning Labels

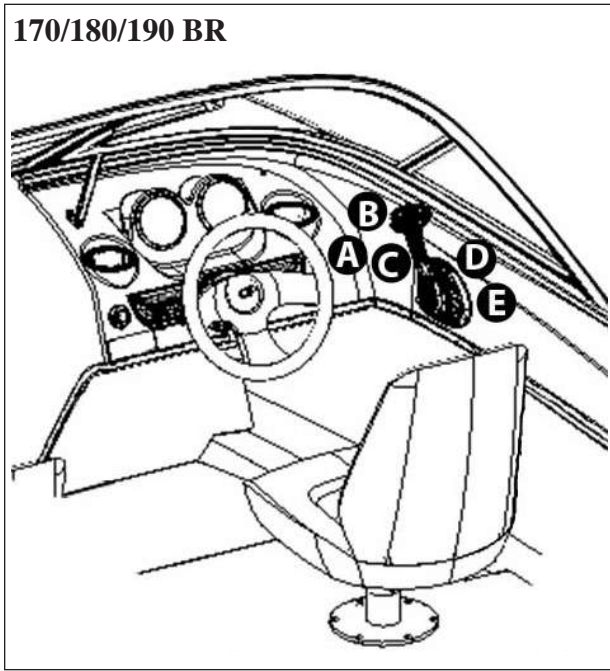

Fish and Ski Option

A **! WARNING**

VISIBILITY FROM THE SEATED POSITION AT THIS HELM STATION IS LIMITED. AVOID SERIOUS INJURY OR DEATH FROM COLLISIONS. OPERATION FROM A STANDING POSITION MAY BE NECESSARY TO MAINTAIN LOOKOUT AS REQUIRED BY RULES OF THE ROAD. READ OWNERS MANUAL.

B **! WARNING**



Carbon monoxide (CO) can cause brain damage or death. Engine and generator exhaust contains odorless and colorless carbon monoxide gas. Signs of carbon monoxide poisoning include nausea, headache, dizziness, drowsiness, and lack of consciousness. Get fresh air if anyone shows signs of carbon monoxide poisoning. See Owner's Manual for information regarding carbon monoxide poisoning.

170 BR

E

U.S. COAST GUARD
MAXIMUM CAPACITIES

6 PERSONS OR 860 LBS

1600 LBS. PERSONS, MOTOR GEAR
130 H.P. MOTOR

THIS BOAT COMPLIES WITH U.S. COAST GUARD SAFETY STANDARDS IN EFFECT ON THE DATE OF CERTIFICATION

MANUFACTURER : BAYLINER MARINE LAKE FOREST, IL
MODEL: 170 BR

DESIGN COMPLIANCE WITH NMMA REQUIREMENTS IS VERIFIED. MANUFACTURER RESPONSIBLE FOR PRODUCTION CONTROL.



NATIONAL MARINE MANUFACTURERS ASSN

180 BR

E

U.S. COAST GUARD
MAXIMUM CAPACITIES

8 PERSONS OR 1087 LBS

1831 LBS. PERSONS, MOTOR GEAR
170 H.P. MOTOR

THIS BOAT COMPLIES WITH U.S. COAST GUARD SAFETY STANDARDS IN EFFECT ON THE DATE OF CERTIFICATION

MANUFACTURER : BAYLINER MARINE LAKE FOREST, IL
MODEL: 180 BR

DESIGN COMPLIANCE WITH NMMA REQUIREMENTS IS VERIFIED. MANUFACTURER RESPONSIBLE FOR PRODUCTION CONTROL.



NATIONAL MARINE MANUFACTURERS ASSN

190 BR

E

U.S. COAST GUARD
MAXIMUM CAPACITIES

8 PERSONS OR 1087 LBS

1970 LBS. PERSONS, MOTOR GEAR
200 H.P. MOTOR

THIS BOAT COMPLIES WITH U.S. COAST GUARD SAFETY STANDARDS IN EFFECT ON THE DATE OF CERTIFICATION

MANUFACTURER : BAYLINER MARINE LAKE FOREST, IL
MODEL: 190 BR

DESIGN COMPLIANCE WITH NMMA REQUIREMENTS IS VERIFIED. MANUFACTURER RESPONSIBLE FOR PRODUCTION CONTROL.



NATIONAL MARINE MANUFACTURERS ASSN

C

THE UNITED STATES COAST GUARD (USCG) RECOMMENDS THAT ALL OCCUPANTS WEAR APPROVED PERSONAL FLOATION DEVICES (PFDs).

! DANGER

PROPELLER(S) MAY CAUSE SERIOUS INJURY OR DEATH

Shut-off engine(s) when near swimmers, prior to using sunpads, swim platform, or boarding ladder.

! WARNING

AVOID COLLISIONS-

- Maintain lookout as required by the "Rules of the Road"
- Visibility can be limited by high boat trim angles, persons, gear, weather and atmospheric conditions.
- At all times proceed at a safe speed, in order to take proper and effective action to avoid hazardous conditions.

SUCH ISSUES ARE UNDER THE CONTROL OF THE OPERATOR!

AVOID SKI LINES AND TOW ROPES-
Ski lines and tow ropes can backlash into the cockpit when released.

! CAUTION

AVOID INHALATION OF TOXIC FUMES-
If fire extinguishing system discharge occurs, ventilate space before entering.

D

MEETS U.S. EPA EVAP STANDARDS USING CERTIFIED COMPONENTS
Bayliner Marine, Lake Forest, IL

Chapter 2: Locations

Exterior Views

Hull Views

160/170/180/190 BR

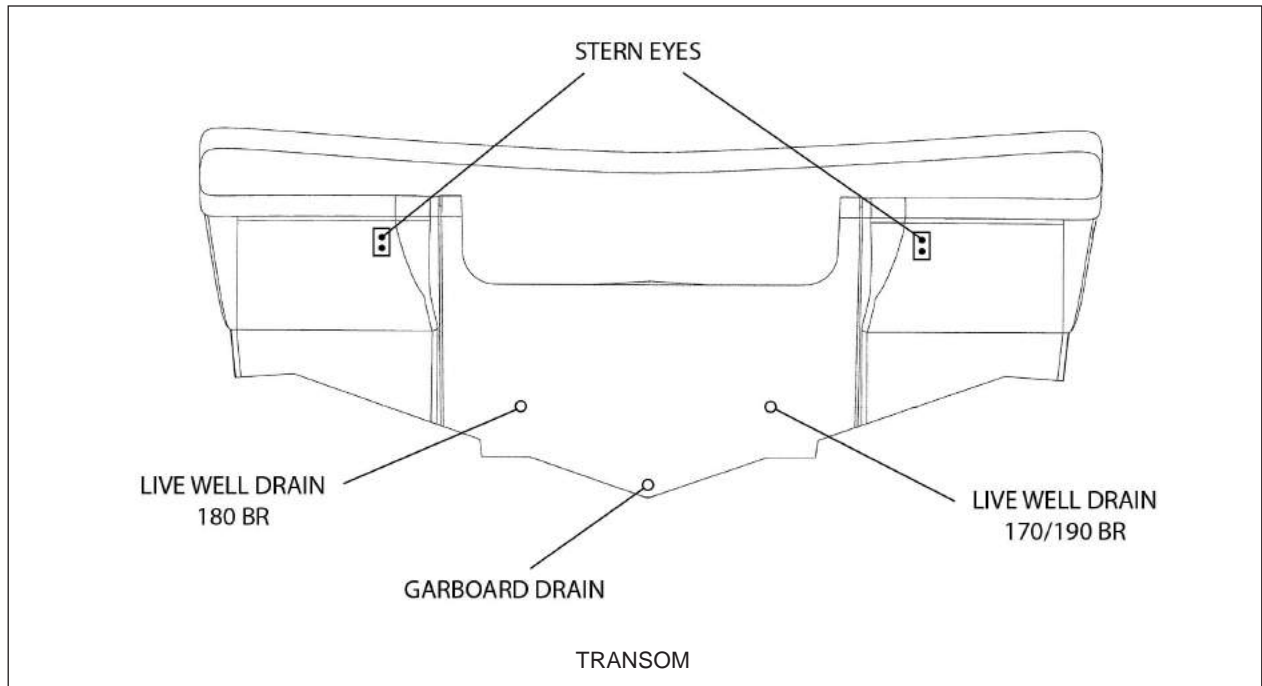
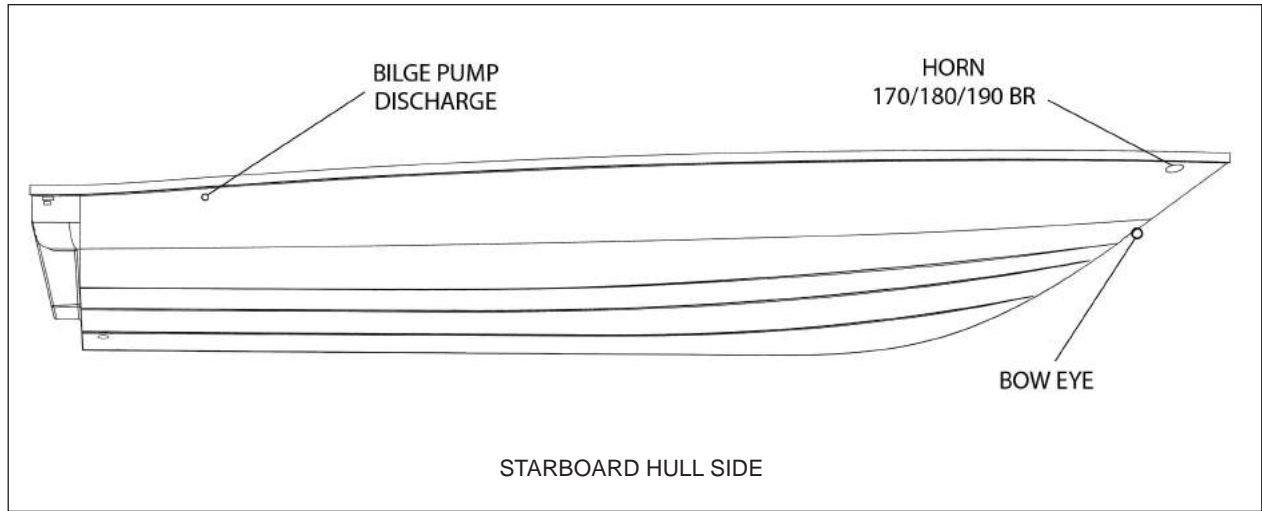

Deck Views

160 BR

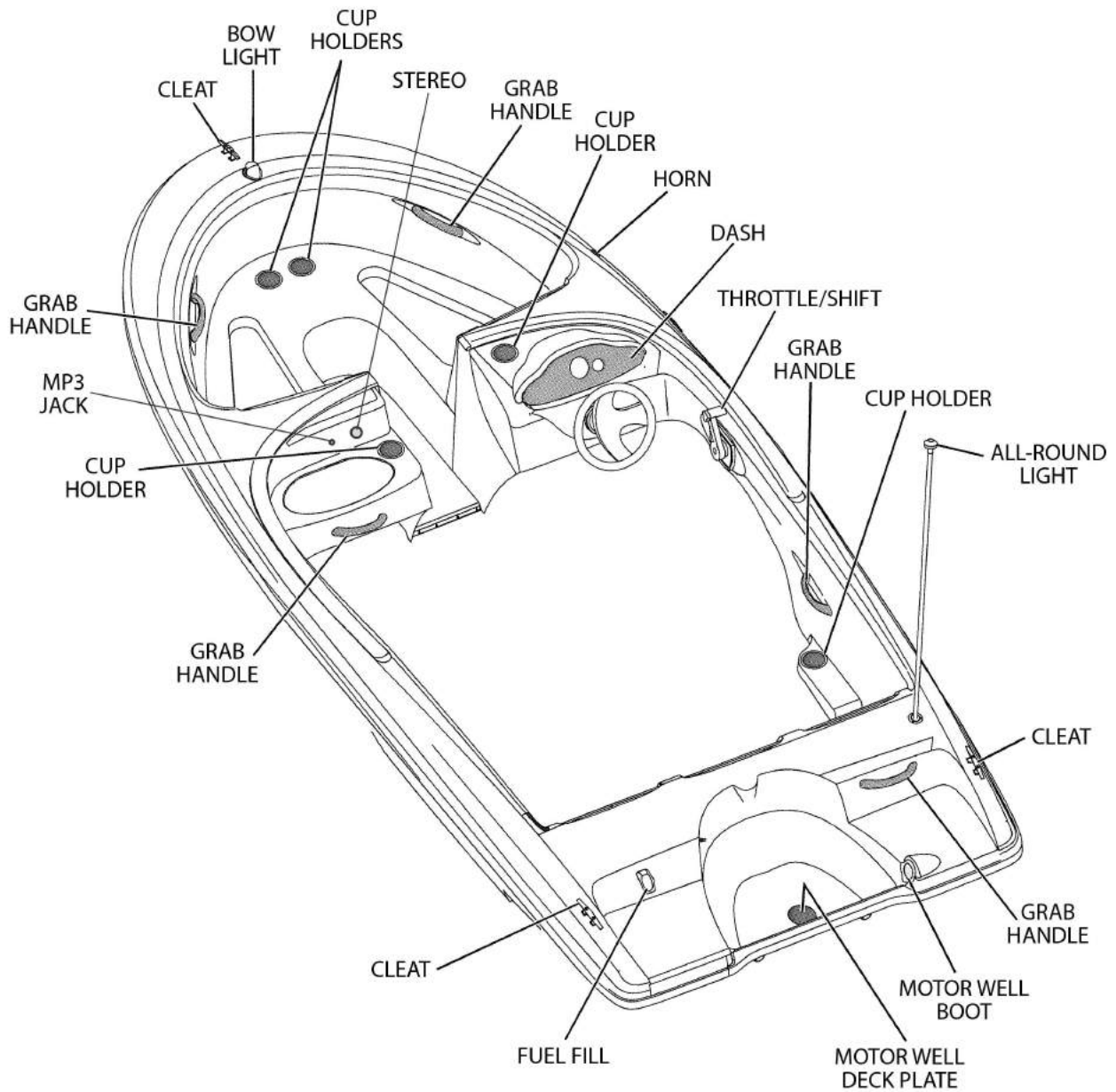

170 BR

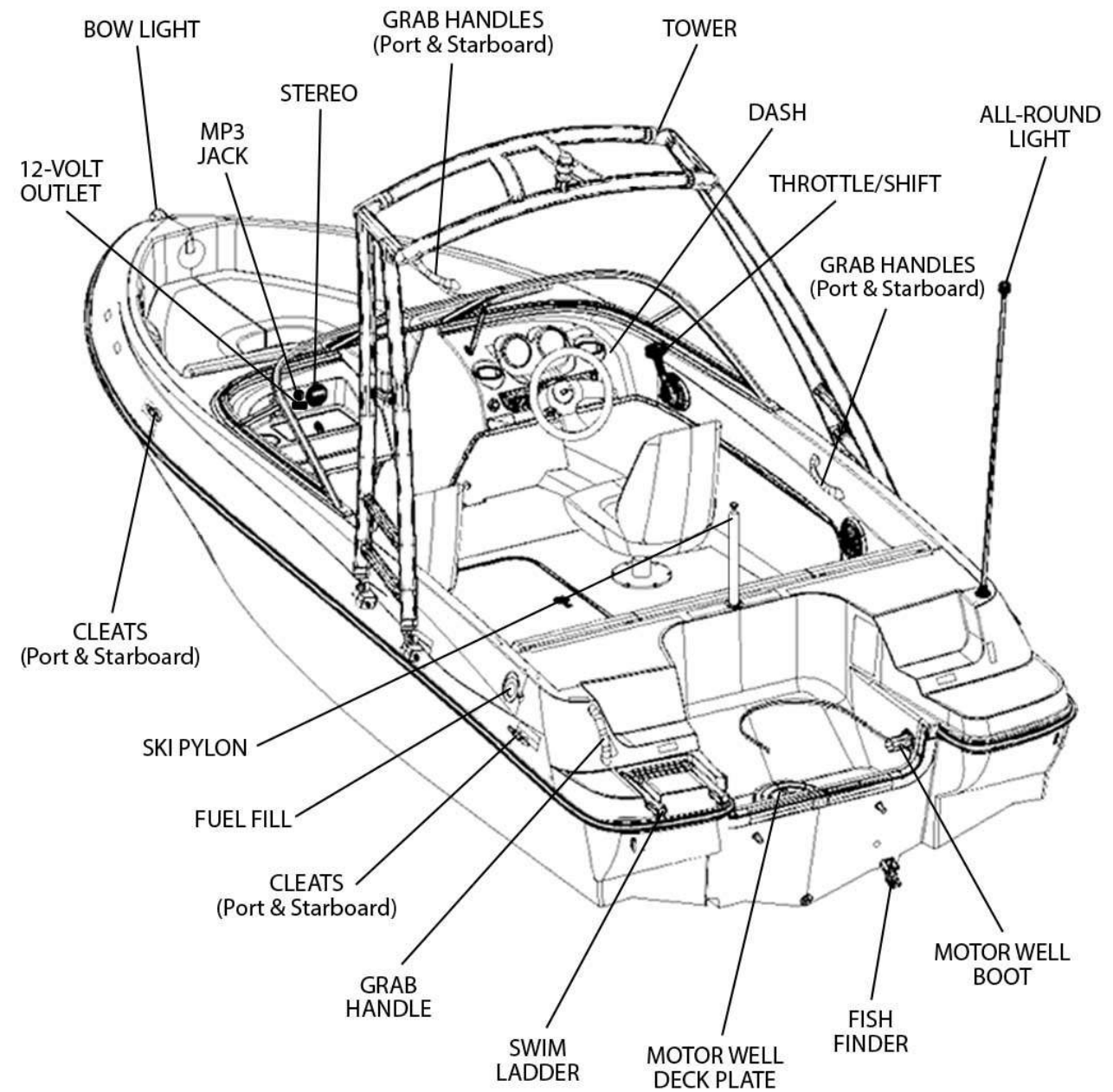

180/190 BR

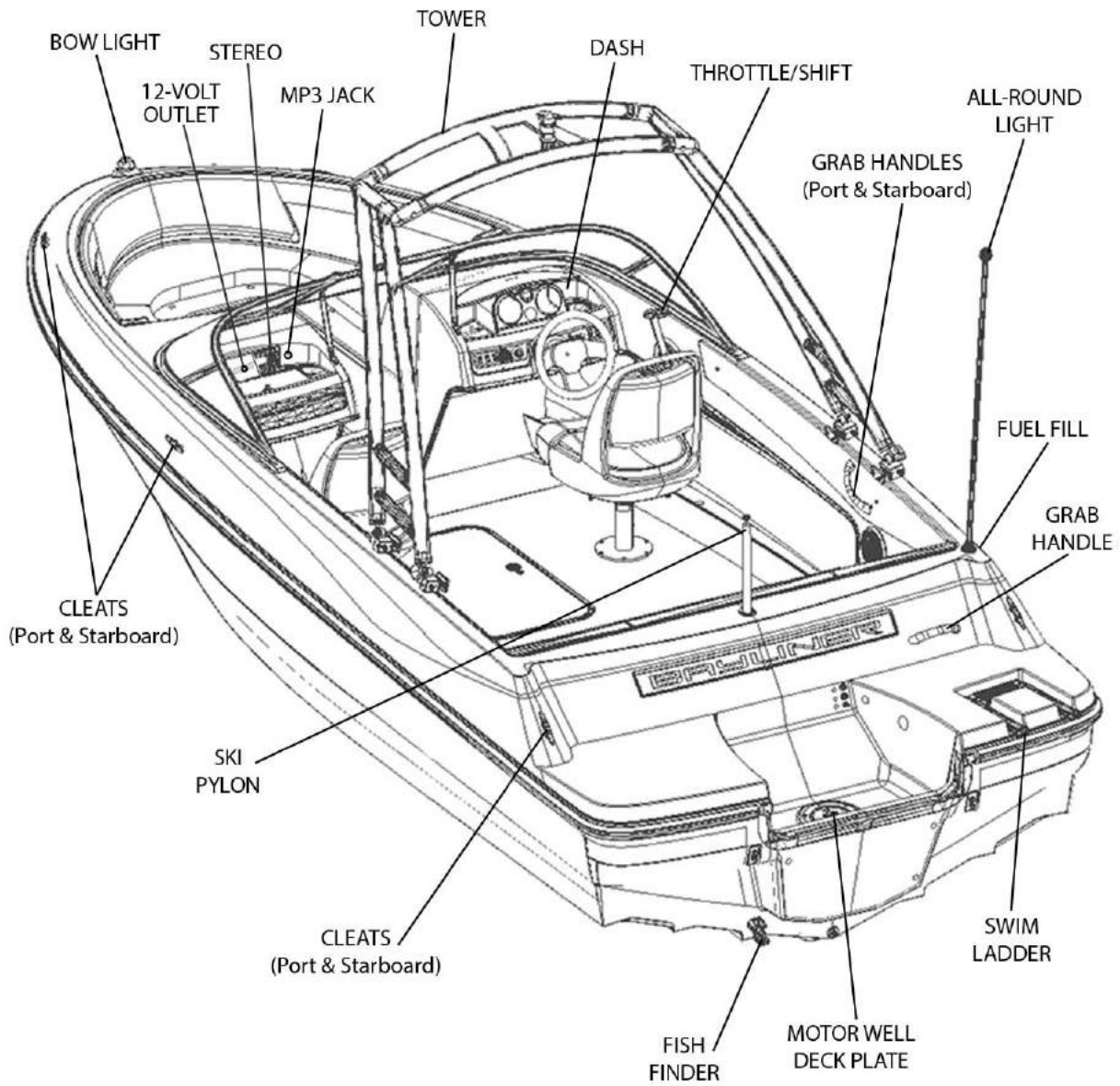

Helm Views

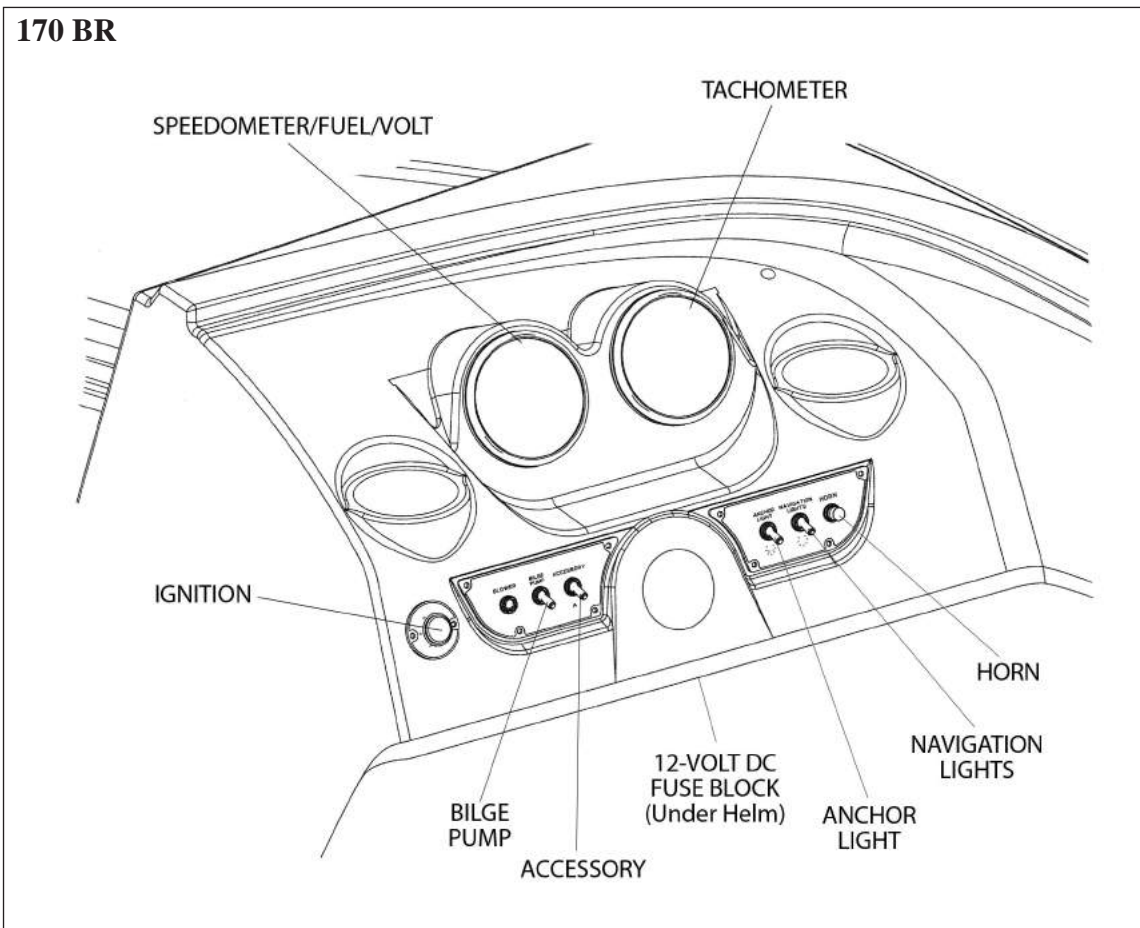
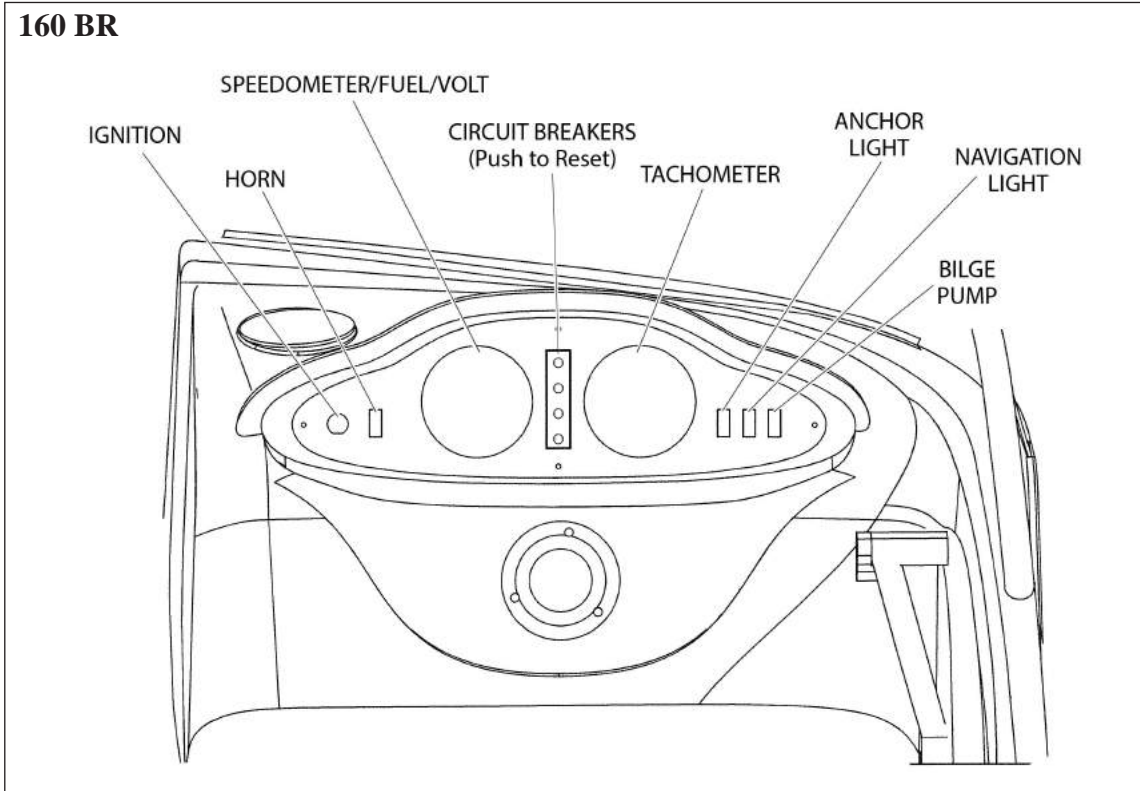

180/190 BR

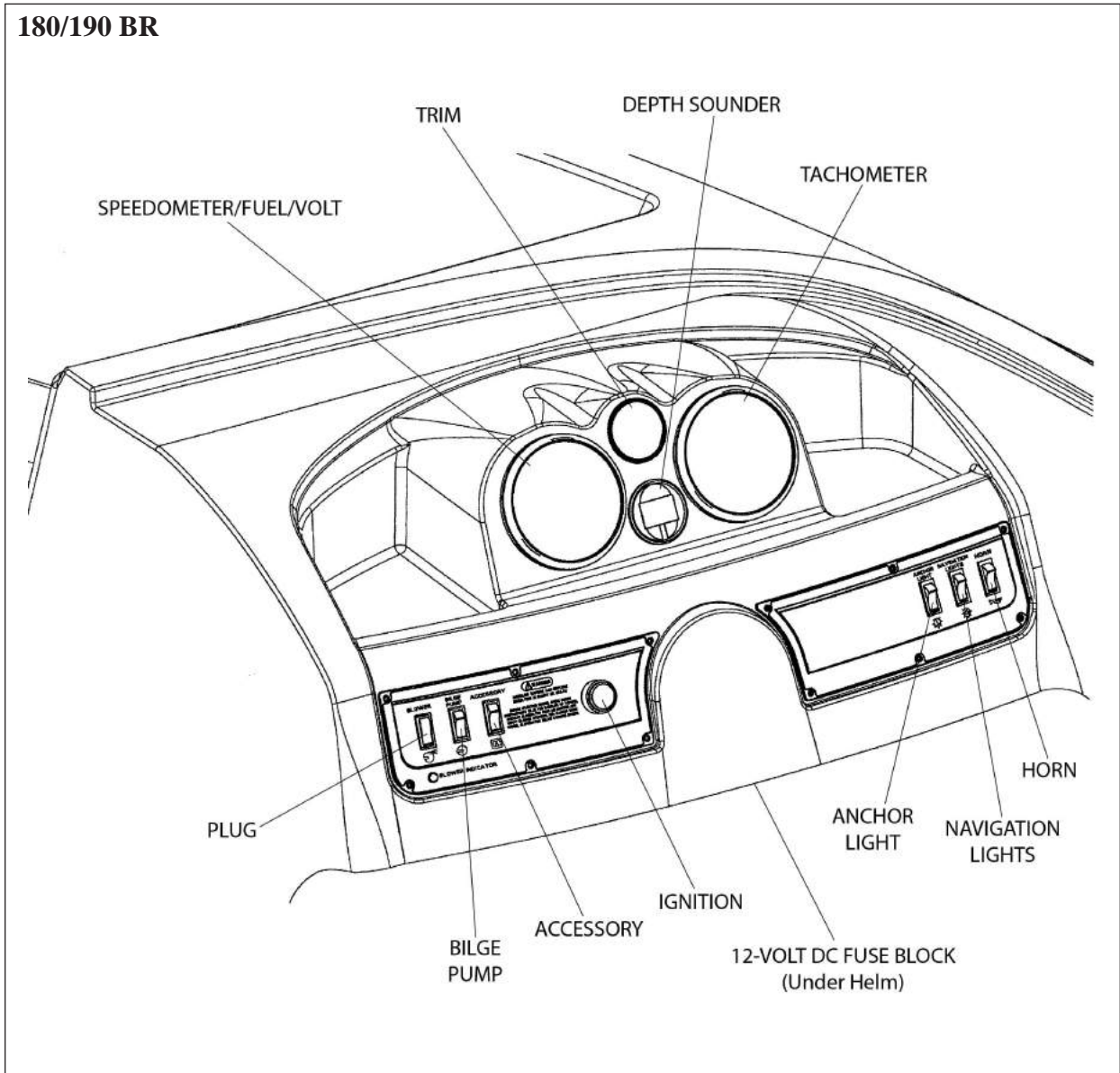

Component Locations

Bilge Components

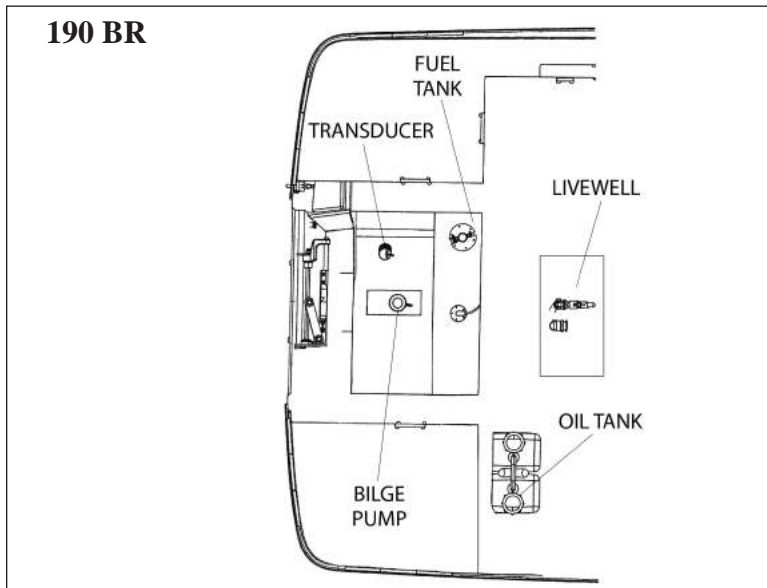
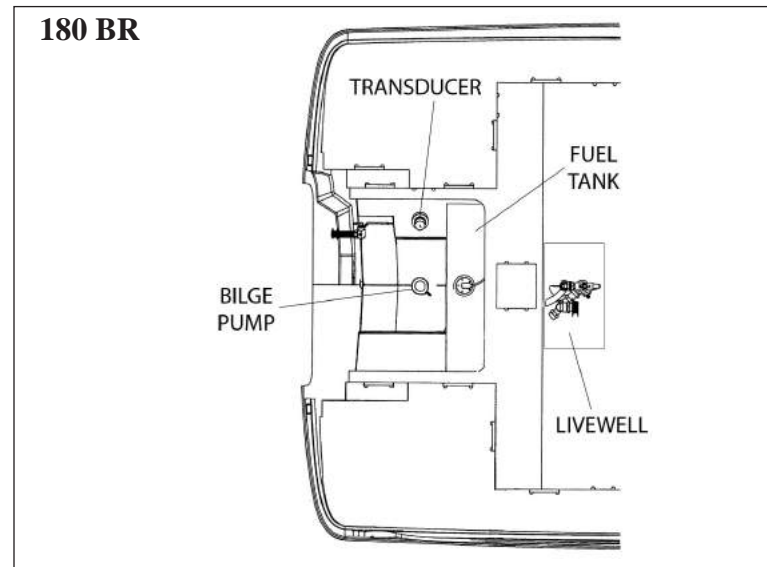
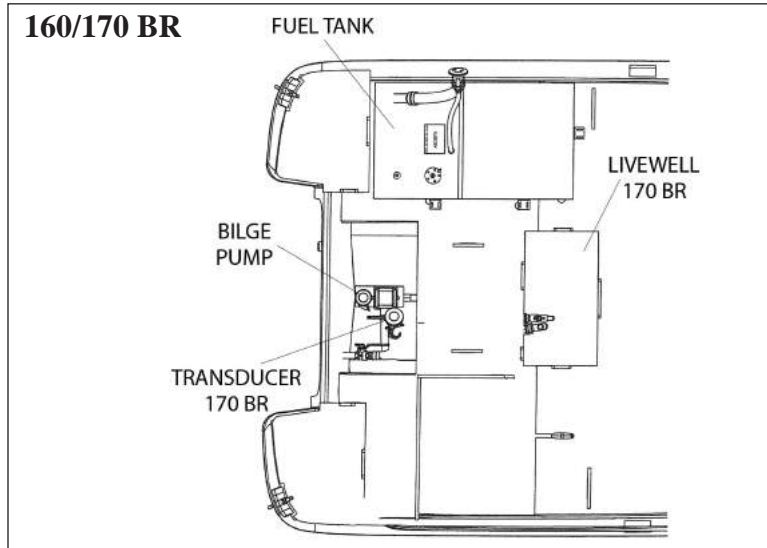

Battery

- Located as shown on either the starboard or the port side of the aft cockpit storage compartment.
- Access is through the opening in the aft cockpit seat.

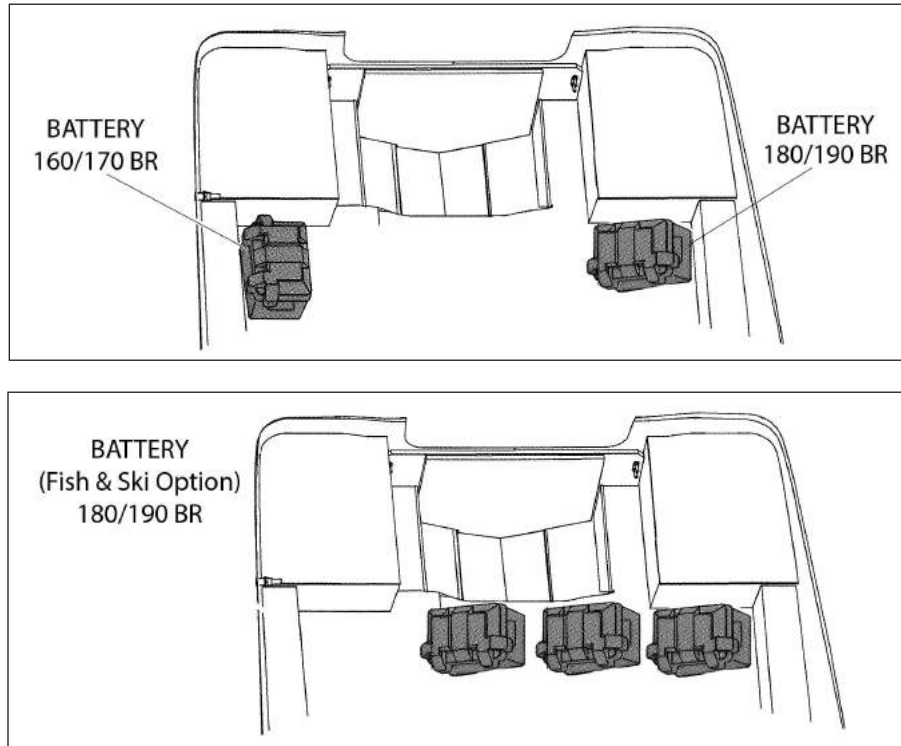

Port Hull Components

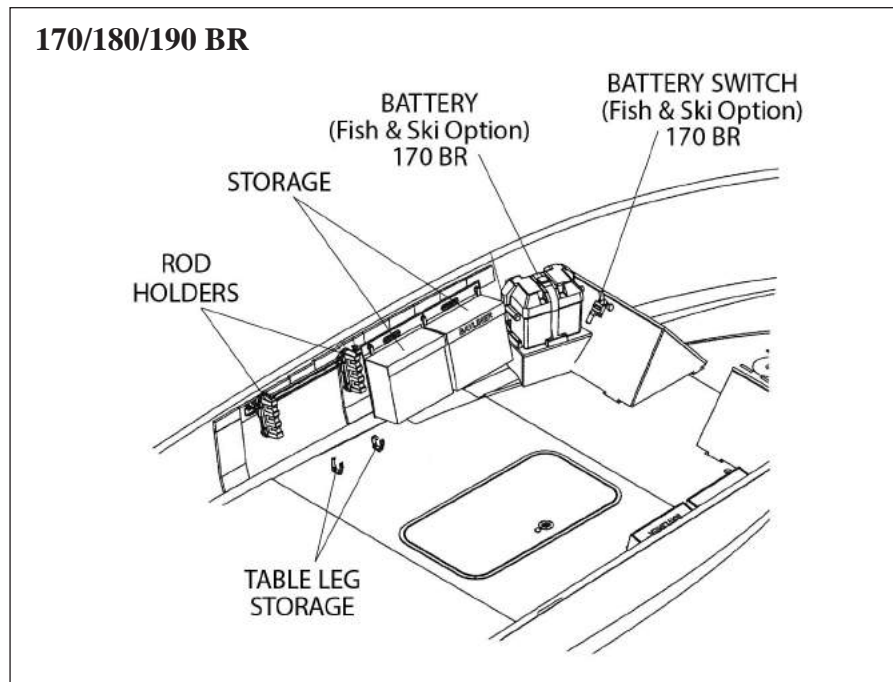

Chapter 3: Propulsion and Related Systems

Engine

NOTICE

Read the engine manual BEFORE starting or working on your engine.

While the topics listed below may be included in this supplement and in the *Sport Boat Owner's Manual*, always refer to the engine manual first for specific information on these important subjects:

- Engine Break-in Procedure
- Engine Starting and Stopping
- Gear Shifting
- Fuel and Oil Recommendations
- Engine Maintenance
- Engine Storage/Winterization

Gasoline Fuel System

The gasoline fuel system consists of a fuel tank, fuel tank vent, anti-siphon valve, engine fuel supply line and fuel fill. Your vessel contains a new EPA certified fuel system. The system prevents spit back when filling the tank and lowers the out gassing emissions through the tank and vent.



WARNING

FIRE, EXPLOSION, and OPEN FLAME HAZARD!

- Thoroughly inspect the fuel system for leaks every time you take on fuel.
- Follow both the *Sport Boat Owner's Manual* fueling instructions and the engine operation manual fuel recommendations.



CAUTION

Avoid the storage or handling of gear near the fuel lines, fittings and tank.

NOTICE

Carefully read the fuel section of both the *Sport Boat Owner's Manual* and the engine operation manual, paying special attention to the subject of fuel recommendations.

Fuel System Layouts

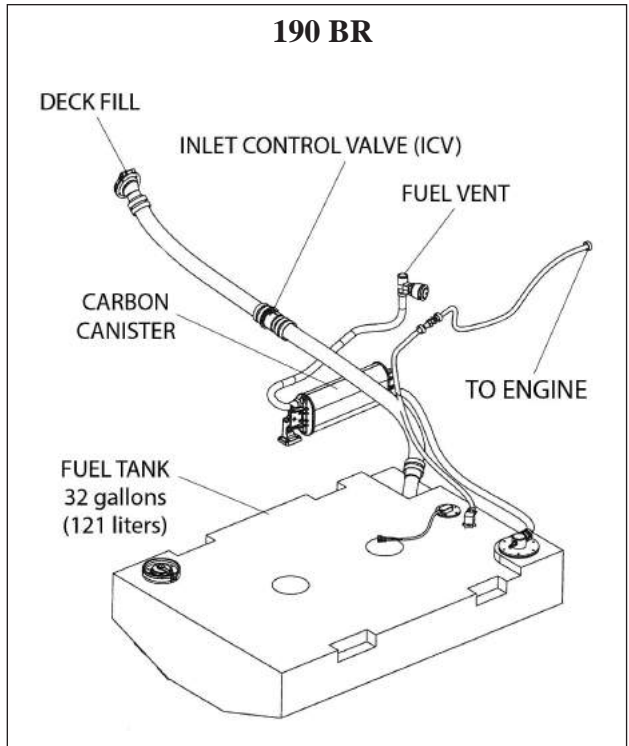
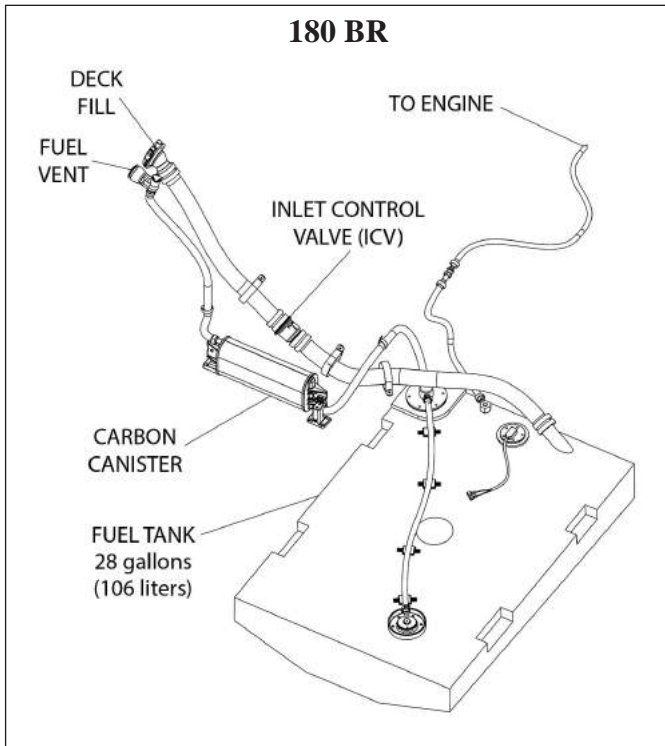
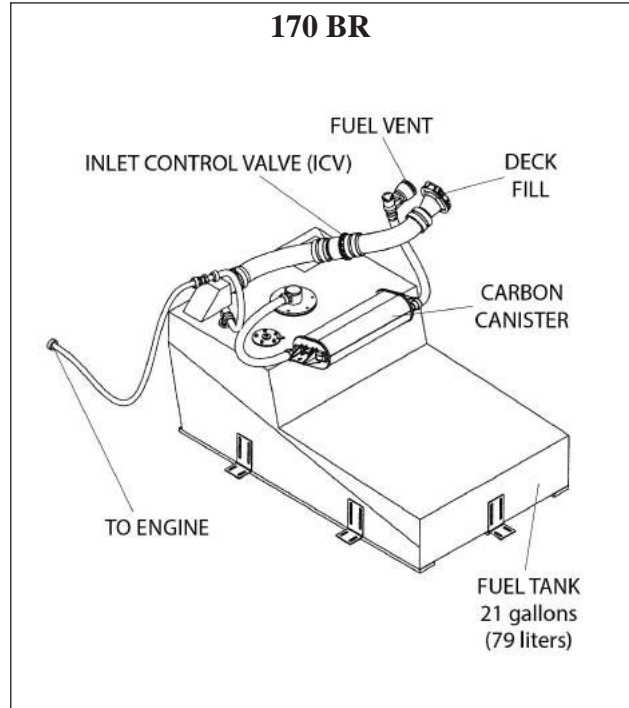
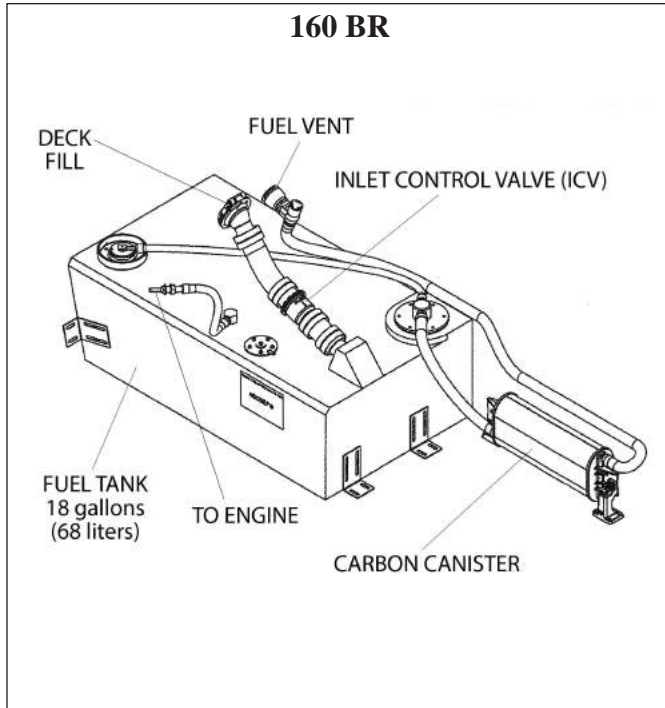

Fuel Tank Vent and Fuel Fill

Your boat is equipped with a fuel tank vent for each tank which serves as a pressure/vacuum release. Periodically check the vents to assure that they are not clogged.

The fuel fill deck fitting is marked GAS. If you have problems filling the fuel tank, see if the fuel fill hose or fuel tank vent hose is kinked or collapsed. If there are no visible signs of a problem, contact your local dealer.

Anti-Siphon Valve

NOTICE

- If an engine running problem is diagnosed as fuel starvation, check the anti-siphon valve.
- If the valve is stuck or clogged, turn Off the engine and then repair or replace the valve.
- Except in an emergency, NEVER run the engine without the anti-siphon valve.

The anti-siphon valve is a vital fuel system part.

If the fuel line ruptures, this valve prevents the siphoning of fuel from the tank. The valve is located on the fuel tank, where the fuel feed line attaches to the tank. The valve is spring loaded and is opened by the fuel pump vacuum.

Carbon Canister Venting System

Your boat is equipped with a carbon canister. This canister filters all the hydrocarbons that pass through the canister. If the carbon canister is mounted in the engine compartment, the canister will have a heat shield. Periodically check that the shield has not become damaged.

Fuel Recommendations

The quality of the fuel is very important for satisfactory engine performance and long engine life. Care should be taken to select fuels having the octane rating recommended for the engine, as indicated in the owner's manual, for proper operation. Fuel should be clean and free of contamination. Your fuel tanks should be kept full of fuel whenever possible. This will reduce the amount of water condensation and reduce the possibility of contamination.

When filling the tank, do NOT attempt to top off the tank. When the fill nozzle shuts off, the tank is full. Continuing to fill past the fuel fill shut off will cause the system to spit back.

Chapter 4: Controls and Gauges

Steering

- Boat steering is not self-centering.
- Your boat features either mechanical rack-and-pinion steering or manual hydraulic steering.
- Check the fluid level in the hydraulic steering reservoir every time you use your boat.
- Refer to the engine manual for steering system details.

Shift/Throttle Controls

WARNING

LOSS OF CONTROL HAZARD!

Improper maintenance of the shift/throttle hardware may cause a sudden loss of control.

Read all of the information about the shift/throttle controls in the shift/throttle manual, the engine operation manual, and the *Sport Boat Owner's Manual*.

Power Trim and Tilt

- The outboard engine on your boat is equipped with power trim and tilt.
- Trim and tilt instructions are provided in the engine operation manual and the shift/throttle manual.

Gauges

Cleaning the Gauges

CAUTION

PRODUCT or PROPERTY DAMAGE HAZARD!

- Use only mild soap and water to clean the gauge lenses and bezels.
- Use of other cleaners, including common window cleaning solutions, may cause the lenses to crack.
- Lenses cracked in this manner will NOT be covered by our warranty.

Gauge Fogging

- Moisture may occasionally find its way into the gauges causing lens fogging.
- Turning On the gauge lights will help dry the lenses.
- Fogging will not harm the gauges.

Radio Transmission Interference

VHF or other radio transmissions may cause brief erratic readings on the tachometer. This will not damage the tachometer gauge or affect its accuracy when not transmitting.

Fuel Gauge

It is normal for the pointer on your fuel gauge to bounce as fuel sloshes back and forth in the fuel tank.

Chapter 5: Navigation Equipment

Read the manuals for all navigation and communication equipment before using these systems.

Depth Finder (If Equipped)



WARNING

- Do NOT use the depth finder as a navigational aid to prevent collision, grounding, boat damage or personal injury.
- When your boat is moving, submerged objects will NOT be seen until they are already under your boat.
- Bottom depths may change too quickly to allow time for your boat to react.
- If you suspect shallow water or submerged objects, run your boat at very slow speeds.

Chapter 6: Plumbing

Bilge Pump

Your boat has a bilge pump for pumping water out of the bilge.

NOTICE

Discharge of oil, oil waste, or fuel into navigable waters is prohibited by law. Violators are subject to legal action by the local authorities.

- The pump's built-in float switch turns On the bilge pump if bilge water rises above a preset level. Small amounts of water in the bilge are normal.
- You can also turn On the bilge pump using the switch at the helm.
- The bilge pump is wired directly to the battery. Unless the battery is dead, the bilge pump should work even when your boat is unattended.

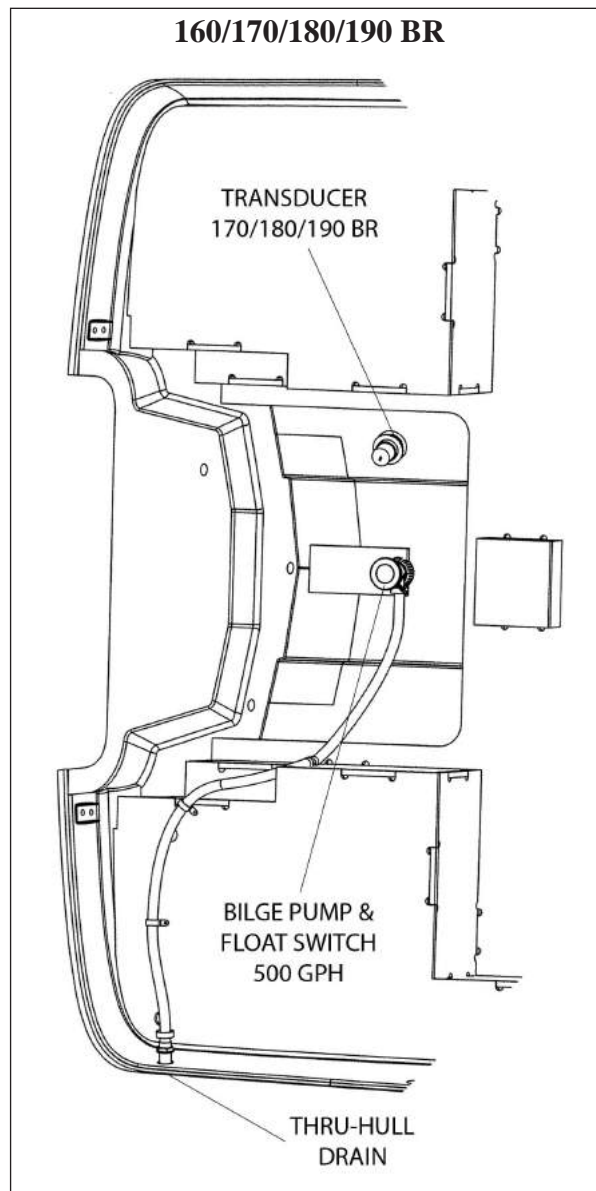

Bilge Pump Testing

The bilge pump is vital to the safety of your boat. Test the bilge pump often as follows:

1. Turn On the bilge pump switch at the helm.
2. Make sure that water in the bilge is pumped overboard.
3. If there is water in the bilge and the pump motor is running but not pumping water, inspect the discharge hose for a kink or collapsed area.
4. If the discharge hose looks okay, check the bilge pump and strainer for clogging debris.

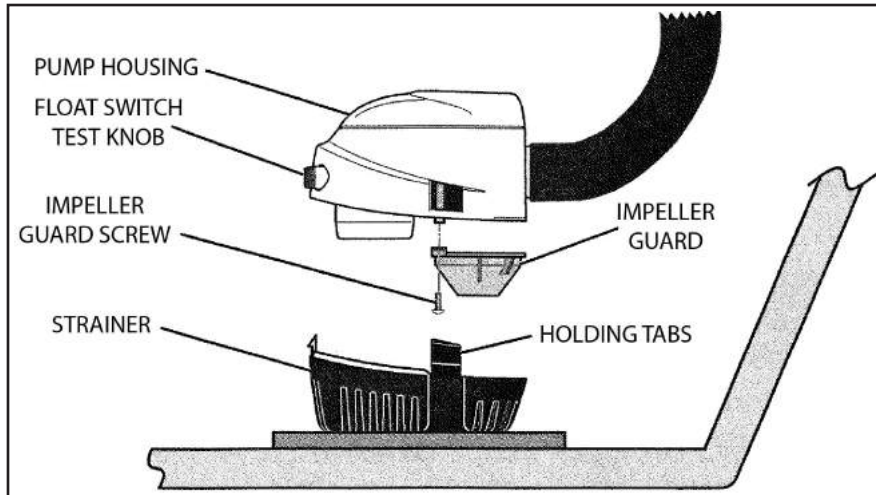

Drain System

Deck Drains

Water on the deck is drained overboard through the deck drains. Keep the deck drains free of debris.

Livewell System 170/180/190 BR



WARNING

FLOODING and SWAMPING HAZARD!

- Close the seacocks when leaving your boat unattended for any length of time.
- If a seacock is left open, a hose failure could flood the bilge, swamp the batteries, and even sink your boat.
- BEFORE using any system that has a seacock, make sure that the system's seacock is Open.
- Inspect and lubricate all seacocks annually.

Filling and Using the Livewell

1. Insert the plug into the drain fitting at the bottom of the tank.
2. Open the seacock.
3. On the switch panel, turn On the Accessory switch.

The tank should now be filling with water. If water is not pumping into the tank, possible causes are:

- A collapsed hose or clogging debris in the system.
- The seawater intake seacock is Closed.
- The livewell fuse is blown.

To Drain the Livewell

Remove the plug to drain the livewell.

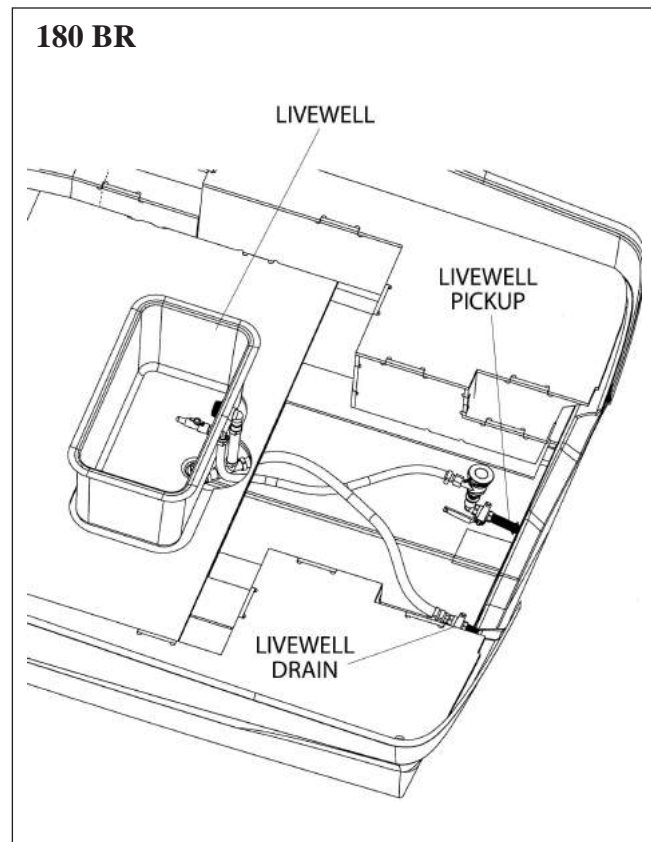
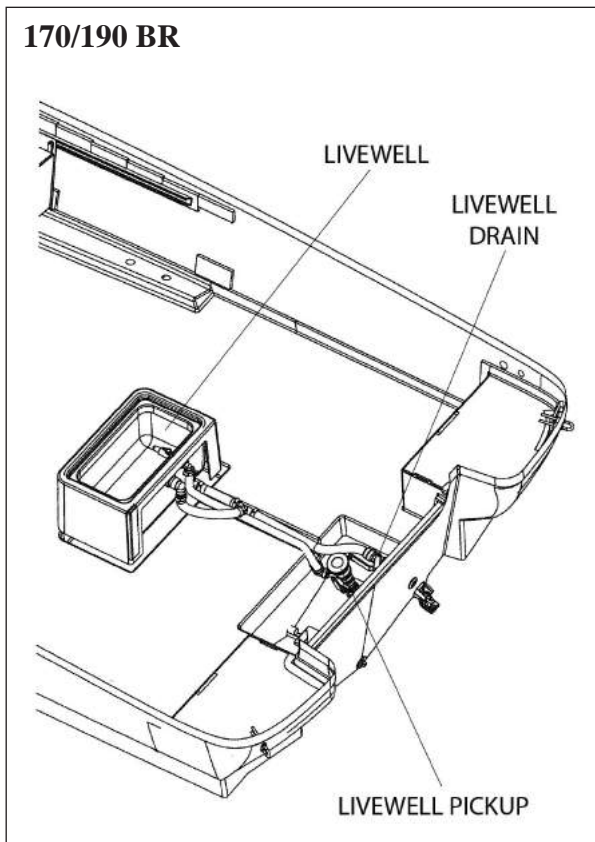

Chapter 7: Deck Equipment

Cleats and Bow/Stern Eyes



WARNING

PERSONAL INJURY and/or PRODUCT or PROPERTY DAMAGE HAZARD!

NEVER lift your boat using the bow/stern eyes or the cleats.

Read the section on towing in the *Sport Boat Owner's Manual* before:

- Towing anything behind your boat
- Being towed by another vessel

Bow Mount Trolling Motor (If Equipped)

Read the manufacturer's instruction manual before using the trolling motor.

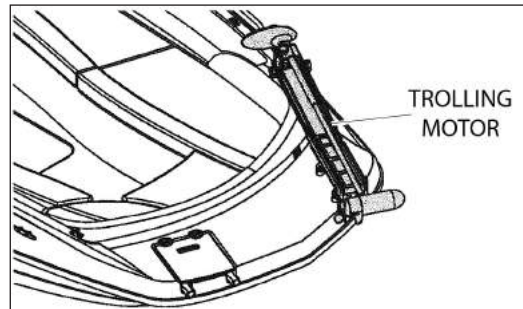

Ski-Tow Pylon (If Equipped)



WARNING

PERSONAL INJURY and/or PRODUCT or PROPERTY DAMAGE HAZARD!

Failure to follow these guidelines can result in injury or death:

- ONLY tow water skis, wakeboards, or recreational towables.
- Do NOT tow parasails, kites, or other boats.
- Do NOT tow more than two persons at one time.
- Use caution with skier in tow as tow rope may snap back into cockpit when released.

Before using the ski-tow pylon, read the *Waterski Safety Guidelines*.

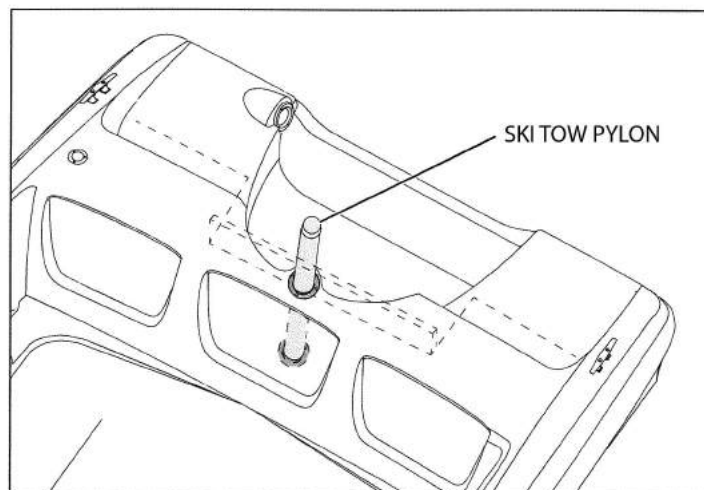

Ski-Tow Tower (If Equipped)



WARNING

PERSONAL INJURY and/or PRODUCT or PROPERTY DAMAGE HAZARD!

Failure to follow these guidelines can result in injury or death:

- Read ALL warning labels on ski-tow tower.
- BEFORE each use of the boat and BEFORE each use of the folding ski-tow tower, make sure the lock-down bolts are tightened firmly.
- ONLY tow water skis, wakeboards, or kneeboards.
- Do NOT exceed the MAXIMUM tow weight of 400 pounds.
- Do NOT tow parasails, kites, tubes, rafts or other boats.
- Do NOT tow more than one person at a time.
- Do NOT climb on, sit on, stand on, jump off or dive off tower.
- NEVER allow passengers to sit behind tow rope attachment point.
- Use caution with skier in tow as tow rope may snap back into cockpit when released.
- NEVER allow loose tow rope ends to dangle off tower.
- When tower is up, watch for low obstacles such as tree limbs, bridges, or power lines.

Attaching the Ski-Tow Rope

1. Place the ski-tow rope's loop (A) over the ski-tow pylon (B).
2. Put a twist in the ski-tow rope's loop (A) and slide the loop over the ski-tow pylon (B) again.
3. Pull firmly on the ski-tow rope to tighten.

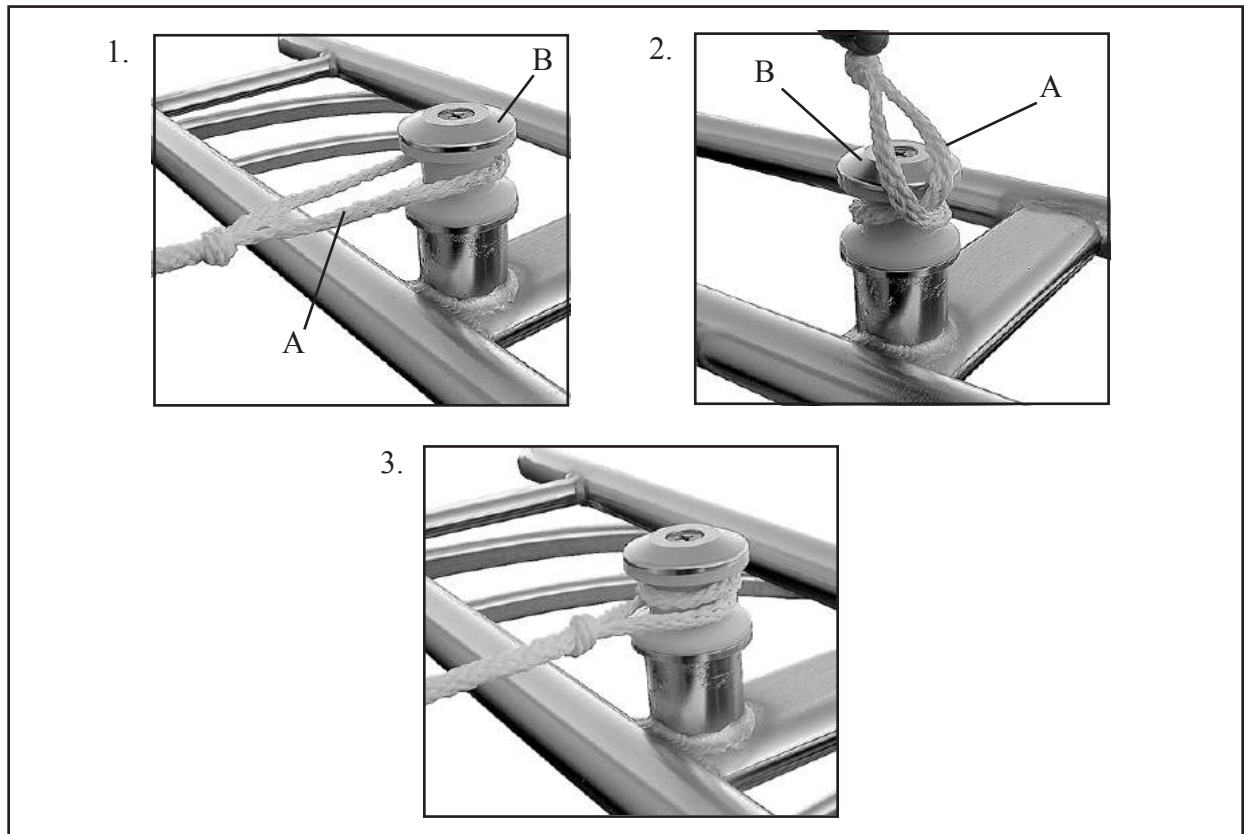

Canvas (If Equipped)



CAUTION

PRODUCT or PROPERTY DAMAGE HAZARD!

Take down and securely stow ALL canvas and vinyl BEFORE your boat is transported by road.

Bimini Top: Option A (If Equipped)

1. Insert the end eyes of the main bow (A) into the middle deck hinges (B) and insert the securing pins.
2. Unfold the canvas and insert the end eyes of the forward braces (C) into the forward deck hinges (D) and insert the securing pins.
3. Insert the end eyes of the aft braces (E) into the aft deck hinges (F) and insert the securing pins.
 - The jaw slides (G) should not need to be adjusted.
 - If you decide to adjust the jaw slide positions, obtain the correct measurements from your selling dealer.

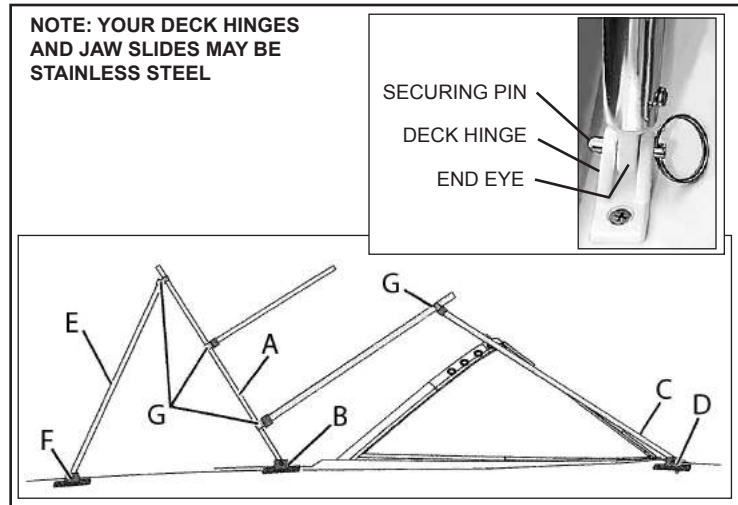

Bimini Top: Option B (If Equipped)

1. Slide the windshield hinges of the main bow (A) over the aft pre-drilled holes (B) in the side windshield frames and insert the securing pins.
2. Unfold the canvas and slide the windshield hinges of the forward braces (C) over the forward pre-drilled holes (D) in the side windshield frames and insert the securing pins.
3. Insert the end eyes of the aft braces (E) into the deck hinges (F) and insert the securing pins.
 - The jaw slides (G) should not need to be adjusted.
 - If you decide to adjust the jaw slide positions, obtain the correct measurements from your selling dealer.

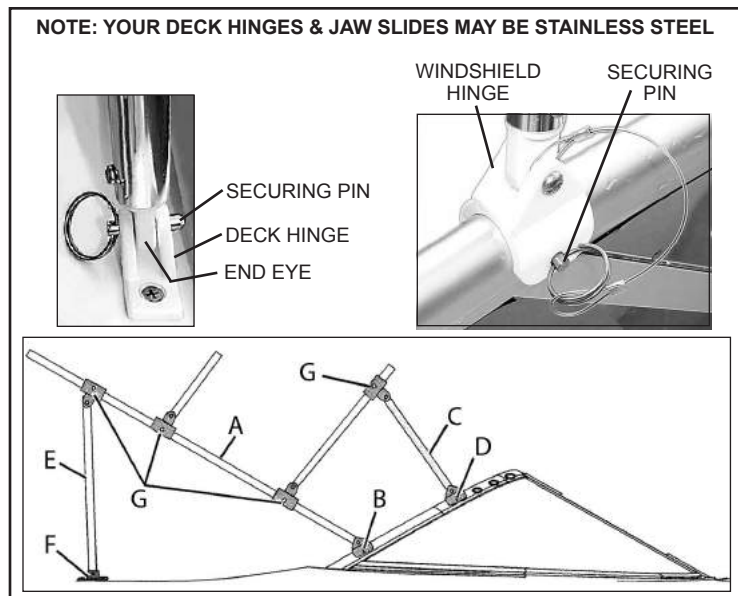

Convertible Top (If Equipped)

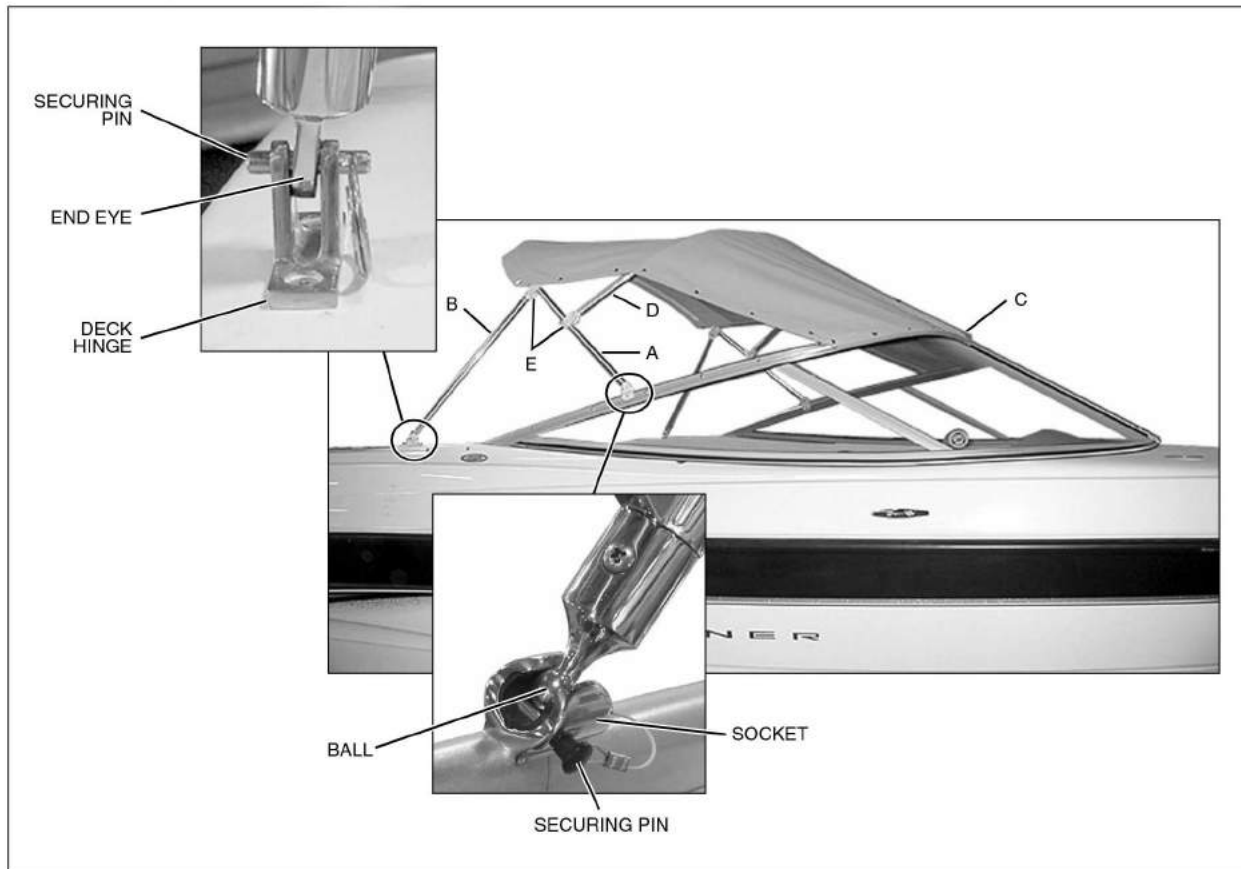

1. Insert the balls of the main bow (A) into the sockets on the windshield frame and secure them with the pins.
2. Insert the end eyes of the aft braces (B) into the deck hinges and secure them with the pins.
3. Unfold the canvas top and snap the front edge of the top (C) to the windshield frame.
4. Align the secondary bow (D) with the center seam of the canvas by loosening or tightening the top straps.
 - The jaw slides (E) should not need to be adjusted.
 - If you decide to adjust the jaw slide position, get the correct measurements from your selling dealer.

Bow Cover (If Equipped)

1. Snap the two forward snaps (A) to the deck.
2. Snap the bow cover to the entire port side.



3. On the starboard side, only snap the forward half of the bow cover to the deck.
4. Insert the adjustable, center support pole (B) into both the bow cover and the table base (C).
5. Adjust the support pole so that it is just high enough to stay inserted in the bow cover.



6. Snap the rest of the bow cover to the deck.
7. Adjust the support pole to take any slack out of the bow cover.



Canvas Care

- After each use, especially in saltwater, rinse the canvas with cold freshwater.
- Before stowing, let the canvas air-dry completely.
- The canvas can be rolled or folded for stowage.

Cleaning the Canvas



CAUTION

NEVER use detergents when washing the canvas. Detergents can destroy the water repellency, and mildew/UV resistant finish of your canvas.

Regularly clean the canvas to prevent dirt, pollen, etc. from embedding in the fabric. Generally, it is easiest to wash the canvas while it is installed on your boat.

1. Use a soft-bristled brush to remove all dust and loose dirt.
2. Hose down the canvas with freshwater.
3. Gently wash the canvas with a solution of lukewarm water (no more than 100° F) and non-detergent mild soap, such as Ivory Snow®, Dreft®, or Woolite®.
4. Rinse thoroughly to remove the soap.
5. Before stowing, let the canvas dry completely.

Stubborn Stains



CAUTION

Soaking in bleach solutions may remove the waterproof finish of the fabric and may also decrease the life of the polyester thread used in the canvas. If needed, a water repellent treatment should be reapplied to your canvas. Ask your dealer about the treatments available for your boat's canvas.

Some stubborn stains may resist normal washing and you can try the methods below. However, these methods may remove the waterproof finish of the fabric and may also decrease the life of the polyester thread used in the canvas. Reapply a water repellent treatment as needed.

Method 1:

1. Add 1/8 cup (1 oz.) of non-chlorine bleach to one gallon of water and mix thoroughly.
2. Thoroughly wet the canvas and then gently scrub the stained area with the weak bleach solution.
3. Rinse with cold water to remove all of the solution.

Method 2:

1. Add 1/2 cup (4 oz.) of non-chlorine bleach and 1/2 cup (4 oz.) Ivory Snow®, Dreft®, or Woolite® to one gallon of water and mix thoroughly.
2. Soak the canvas in this solution for about 20 minutes.
3. Rinse with cold water to remove all of the solution.

Chapter 8: Entertainment System

Audio System (If Equipped)

NOTICE

AM radio reception may be impaired when the engine is running.

Read the manufacturer's instruction manual before using the audio equipment.

Chapter 9: Convertible Seats



WARNING

FALLING and PRODUCT DAMAGE HAZARD!

NEVER allow anyone to step-on or stand-on a sleeper seat in the lounge position.

Sleeper Seats (If Equipped)

- The sleeper seats can be moved forward and aft while in the upright, operating position.
- The sleeper seats can also be converted into a flat lounge or chaise lounge.

Operating Positions

To slide the seat forward and backward:

1. Pull up on the forward seat slider lever (A).
2. Slide the seats forward or aft to the desired position.

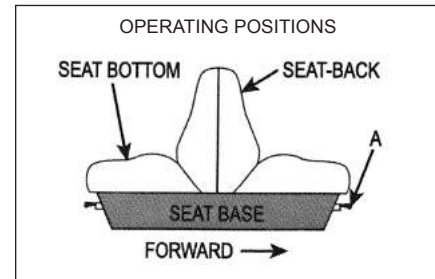

Lounge Positions

To convert into a flat lounge:

1. Pull up on the forward seat slider lever (A) and slide the seats all the way forward.
2. Push down on the aft seat slider lever (B) and slide the aft seat all the way aft.
3. If necessary, push down on the top of the seat-backs (C).

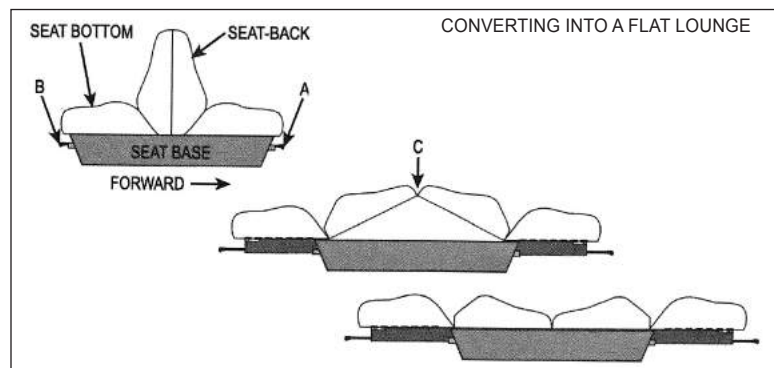

To convert into a chaise lounge:

1. First, convert the seats into a flat lounge as described above.
2. Lift the forward or aft seat bottom at point (D or E) and then lift the plastic seat support bracket (F).
3. Lower the seat until it rests securely on the support bracket.

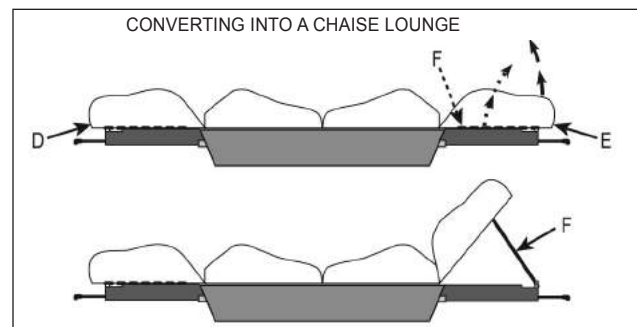

To return the seats to the operating position:

1. Lift the seat-backs at point (C) and push the seat bottoms towards the center of the seat until the seat-backs are flush against each other and locked into place.
2. Push the seat bottoms towards the center of the seat until the seat-backs are flush against each other and locked into place.

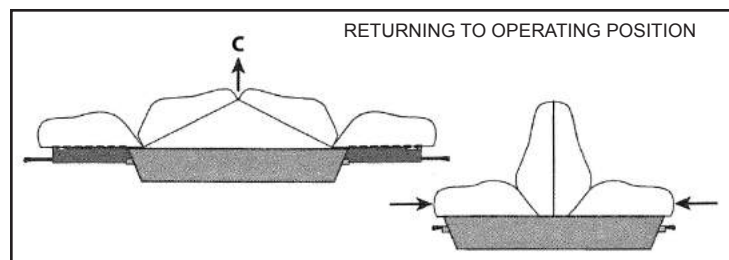

Removable Fishing Seat (If Equipped)

! DANGER

PERSONAL SAFETY HAZARD!

- DO NOT allow anyone to ride on parts of the boat not designated for such use.
- Sitting on the fishing seat while underway is especially hazardous and WILL cause personal injury or death.

Remove and stow the fishing seat in a safe and secure area before getting underway or trailering your boat.

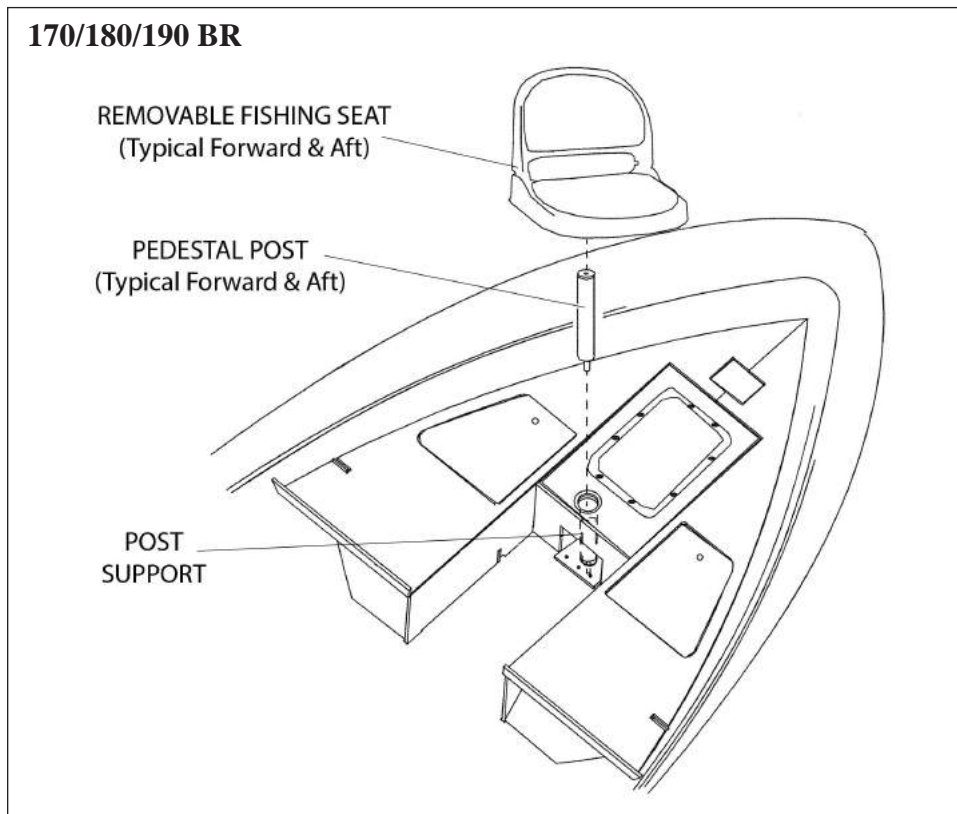

Chapter 10: Lights

Care and Maintenance

All of the lights installed on your boat are of top quality, but you should be aware that failure may periodically occur for a variety of reasons:

- There may be a blown fuse - *replace the fuse.*
- The bulb may be burned out - *carry spare replacement bulbs, making sure the wattage is correct.*
- A wire may be damaged or may have come loose - *repair as required.*
- The bulb base may be corroded - *clean the base and coat it with non-conductive electrical lubricant.*

Interior and Exterior Lights



CAUTION

- Be conservative in the use of battery power.
- Prolonged use of cabin interior lights (overnight) WILL result in a drained battery.

- The lights are powered by your boat's 12-Volt DC system.
- The battery switch must be turned On for the lights to work.

Navigation Lights



CAUTION

Avoid the storage of gear where it would block navigation lights from view.

NOTICE

Running lights are legally required to show boat direction and right-of-way at night.

Read the navigation light section in the *Sport Boat Owner's Manual*.

Chapter 11: Electrical System

DANGER

EXTREME FIRE, SHOCK and EXPLOSION HAZARD!

- NEVER install non-ignition protected switches or other arcing devices in the fuel compartment.
- NEVER substitute automotive parts for marine parts. Marine electrical, ignition, and fuel system parts were designed and manufactured to comply with rules and laws that minimize the risks of fire and explosion.
- NEVER change the electrical systems or relevant drawings.
- Allow ONLY trained personnel to install batteries and/or do electrical system work.

WARNING

FIRE and EXPLOSION HAZARD!

Fuel vapors can explode! BEFORE turning on electrical devices or working on the electrical system:

Check the bilge areas for fuel vapors or leaking fuel. If you see leaking fuel or smell fuel vapors:

- Do NOT start the engine, do NOT turn On any electrical devices, put out ALL cigarettes, cigars, and other sources of flame or ignition.
- Get everyone off your boat.
- Get trained help to find and fix the problem.

CAUTION

SHOCK and ELECTRICAL SYSTEM DAMAGE HAZARD!

When the engine is running, NEVER disconnect the battery cables. Doing so could cause damage to your boat's engine and/or electrical system.

NOTICE

Electrical connections are prone to corrosion. To reduce corrosion-caused electrical problems:

- Keep ALL electrical connections clean.
- Apply a spray-on protectant that is designed to protect connections from corrosion.

12-Volt DC System

Battery

The battery supplies electricity for lights, 12-Volt accessories and engine starting.

The Electrical section in the *Sport Boat Owner's Manual* provides battery care and maintenance instructions.

Fuses and Circuit Breakers

Replace fuse or circuit breakers **ONLY** with a fuse or breaker of the same rating.

- Push-to-reset circuit breakers for main accessory power are at the helm, for 160 BR.
- Fuses for the accessories are on the fuse block, for 170/180/190 BR.

See the Component Locations section in Chapter 2 for the location of the fuse block. Fuses for the engine control and gauges are on the engine. See the engine operation manual.

Some equipment may have secondary fuse protection at the unit or at the battery.

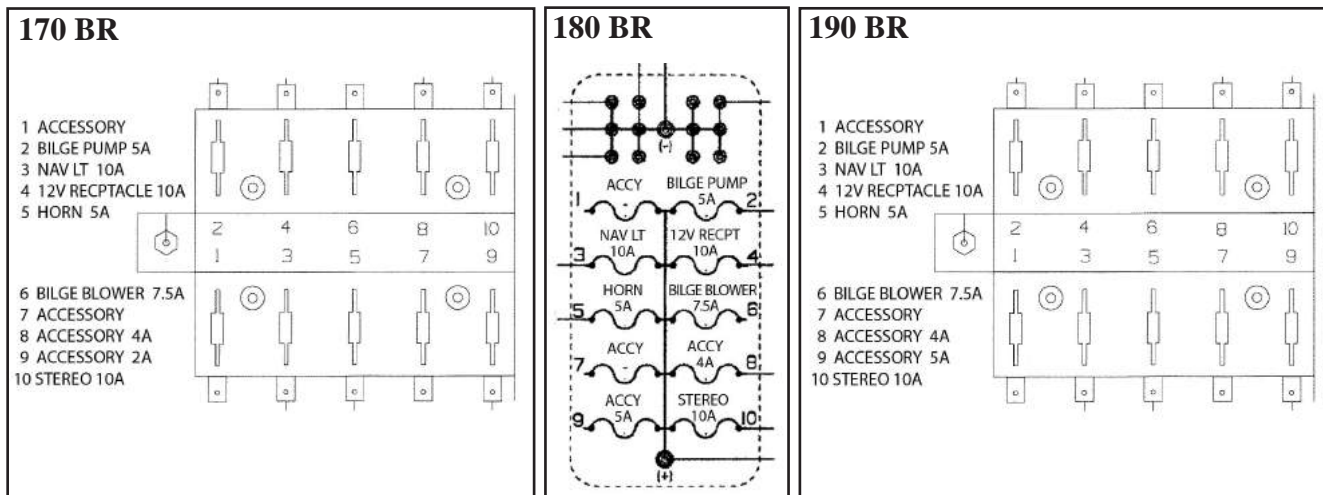

12-Volt DC Accessory Outlet (If Equipped)



CAUTION

Do NOT use the 12-Volt DC accessory outlet with a cigarette or cigar lighter. High temperatures may melt the outlet.

- The 12-Volt DC accessory outlet can be used with any 12-Volt device which draws 10-amps or less.
- The 12-Volt DC accessory outlet is protected by a 10-amp fuse on the fuse block, for 170/180/190 BR.

See the Component Locations section in Chapter 2 for the location of the 12-Volt DC accessory outlet.

Alternator

The alternator will keep the battery properly charged when the engine is running at, or above, cruising speeds.

DC Wiring Schematics

170 BR (1 of 2)

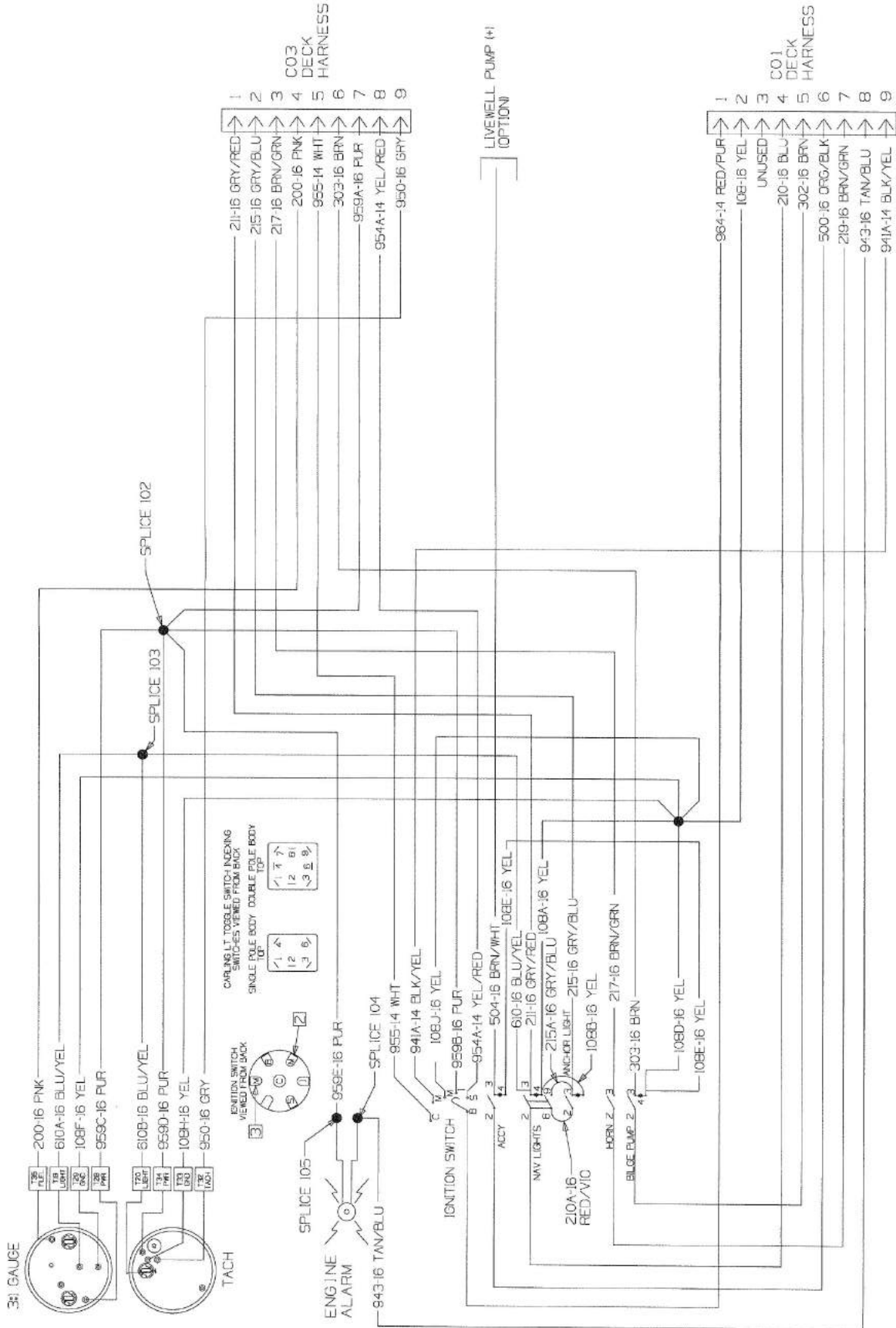

DC Wiring Schematics

170 BR (2 of 2)

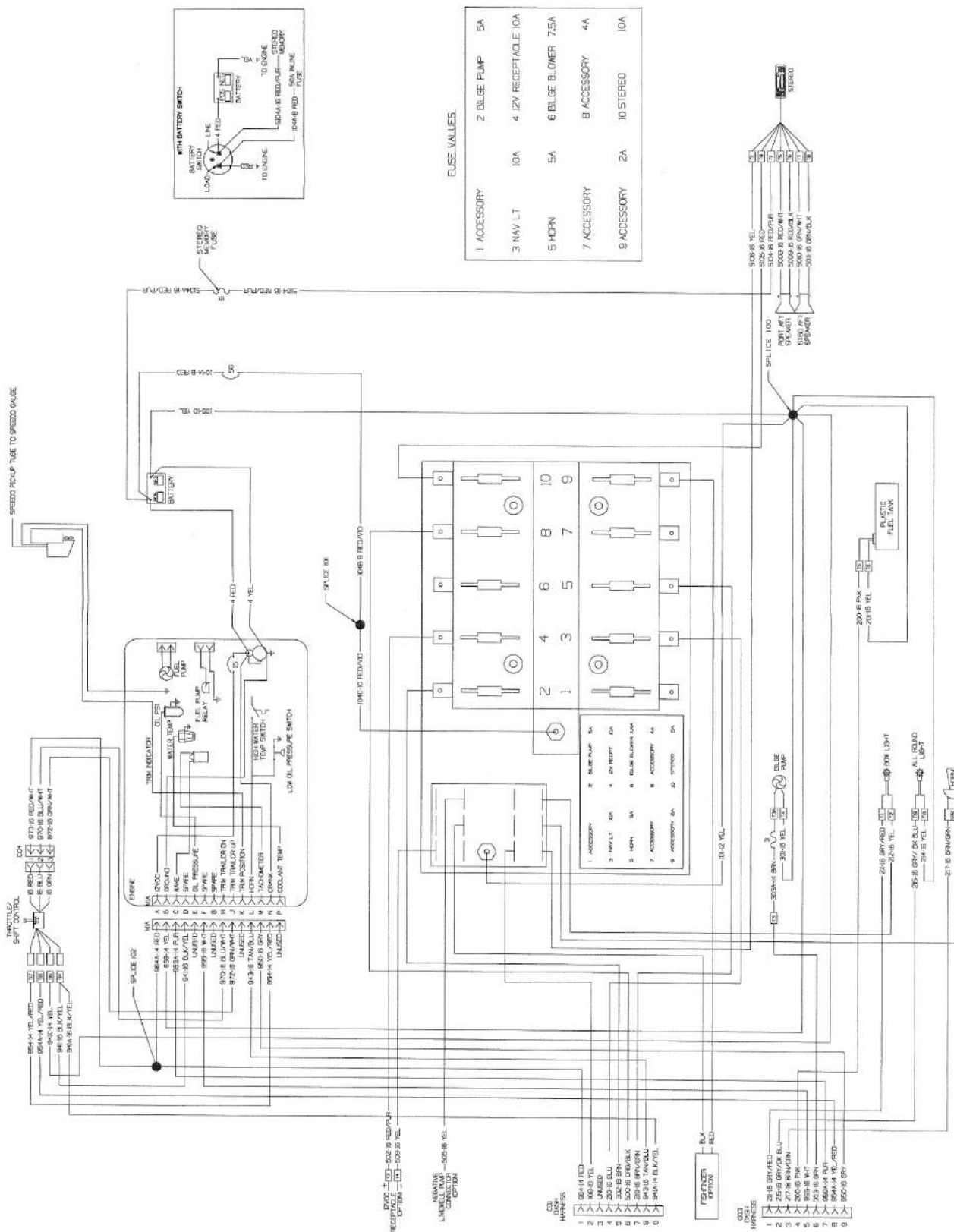

DC Wiring Schematics

180 BR (1 of 2)

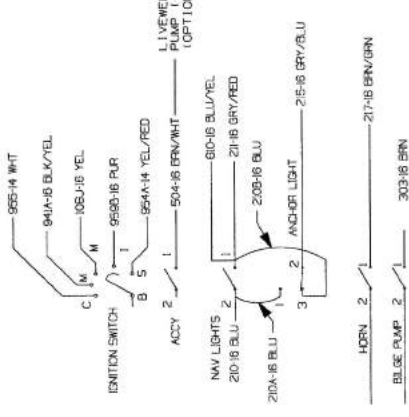
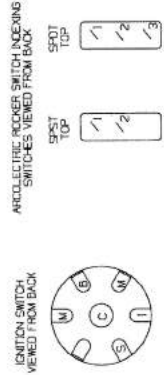
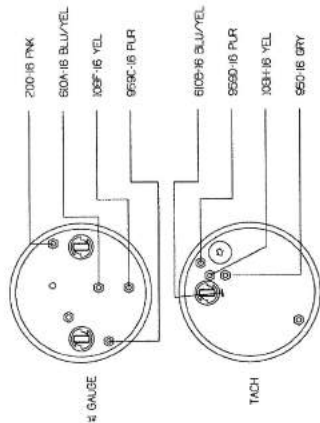
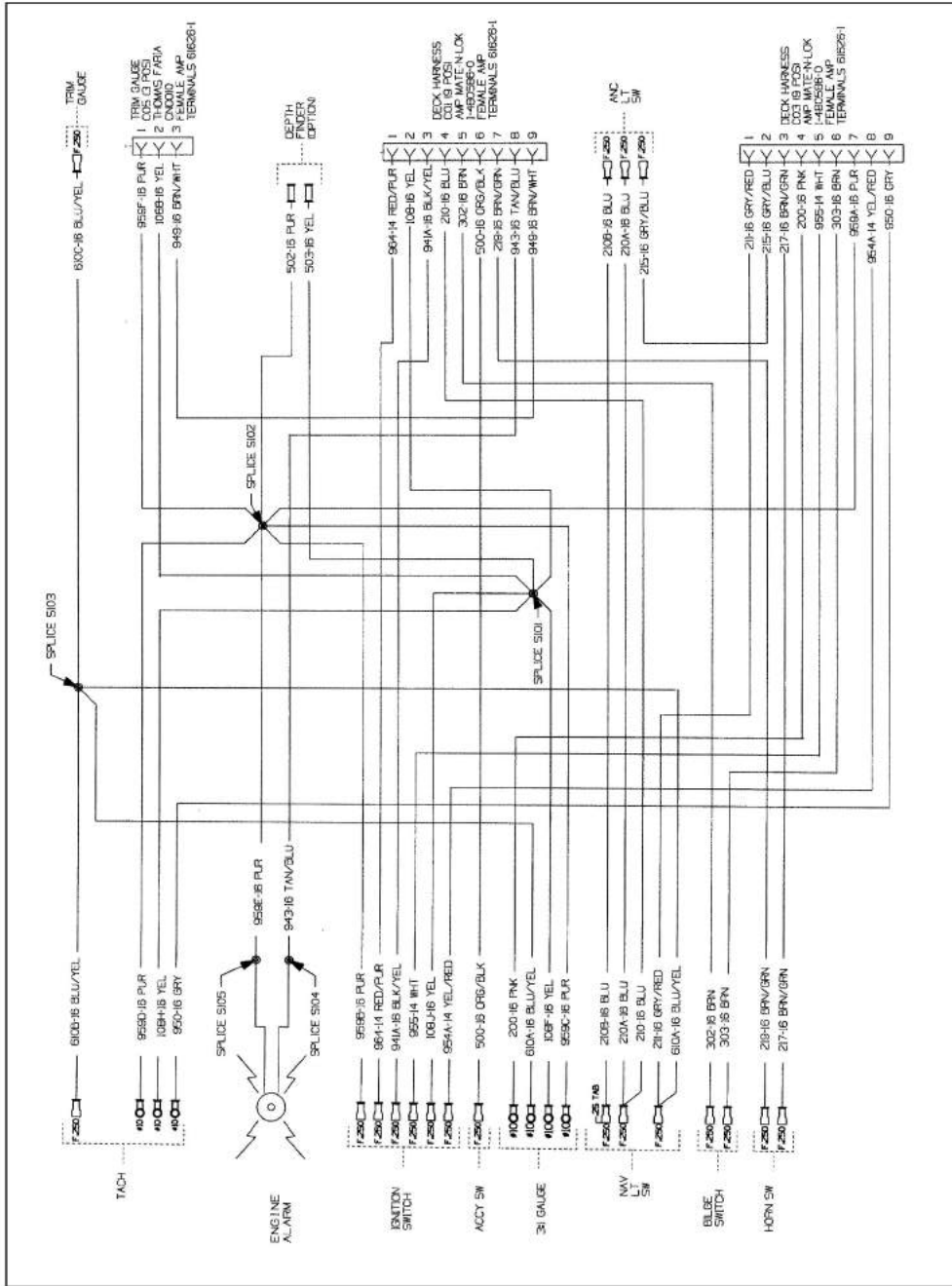

DC Wiring Schematics

180 BR (2 of 2)

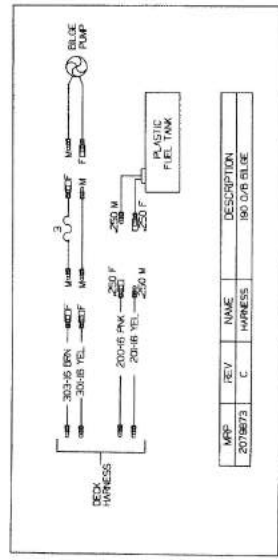
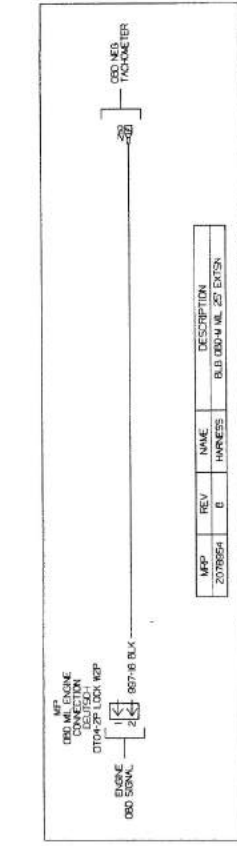
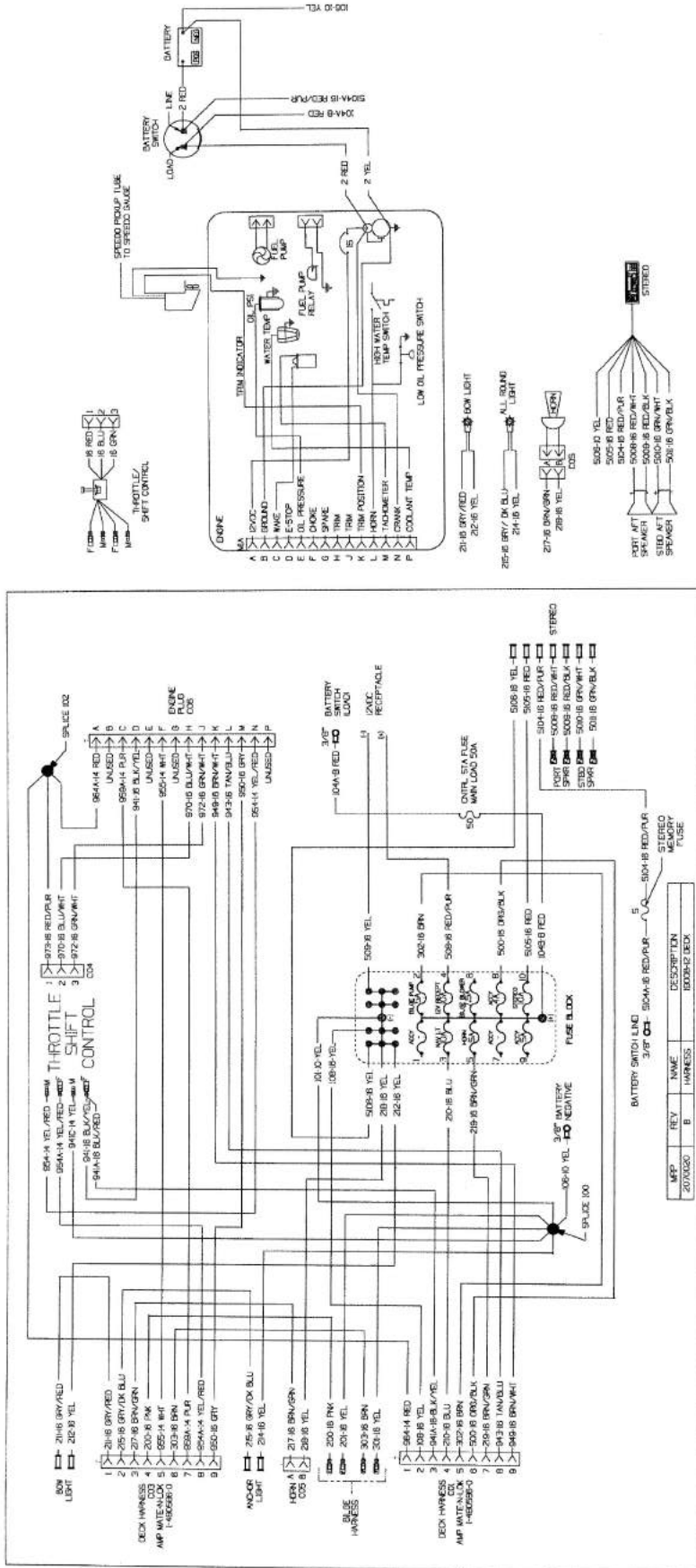

DC Wiring Schematics

190 BR (1 of 2)

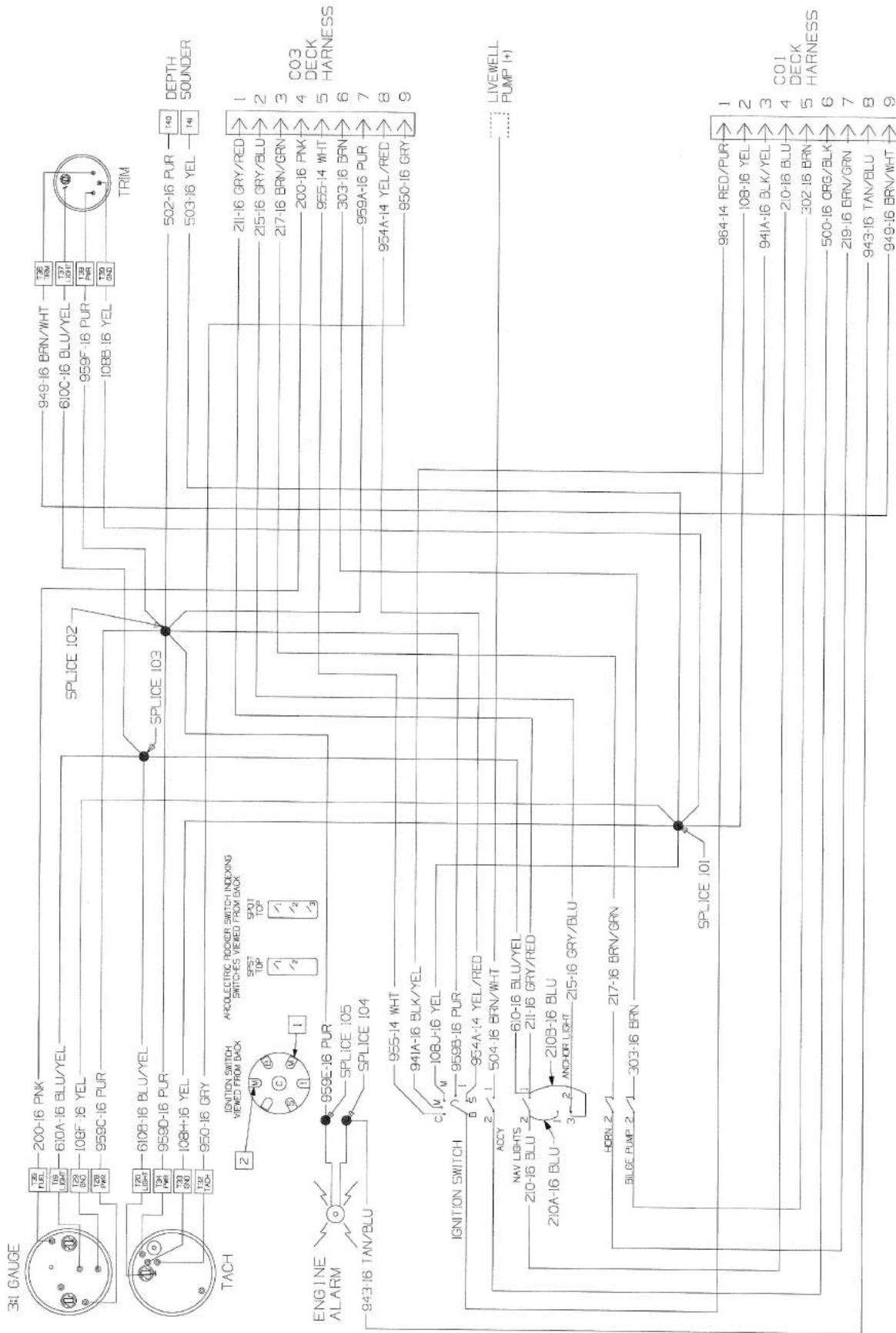

DC Wiring Schematics

190 BR (2 of 2)

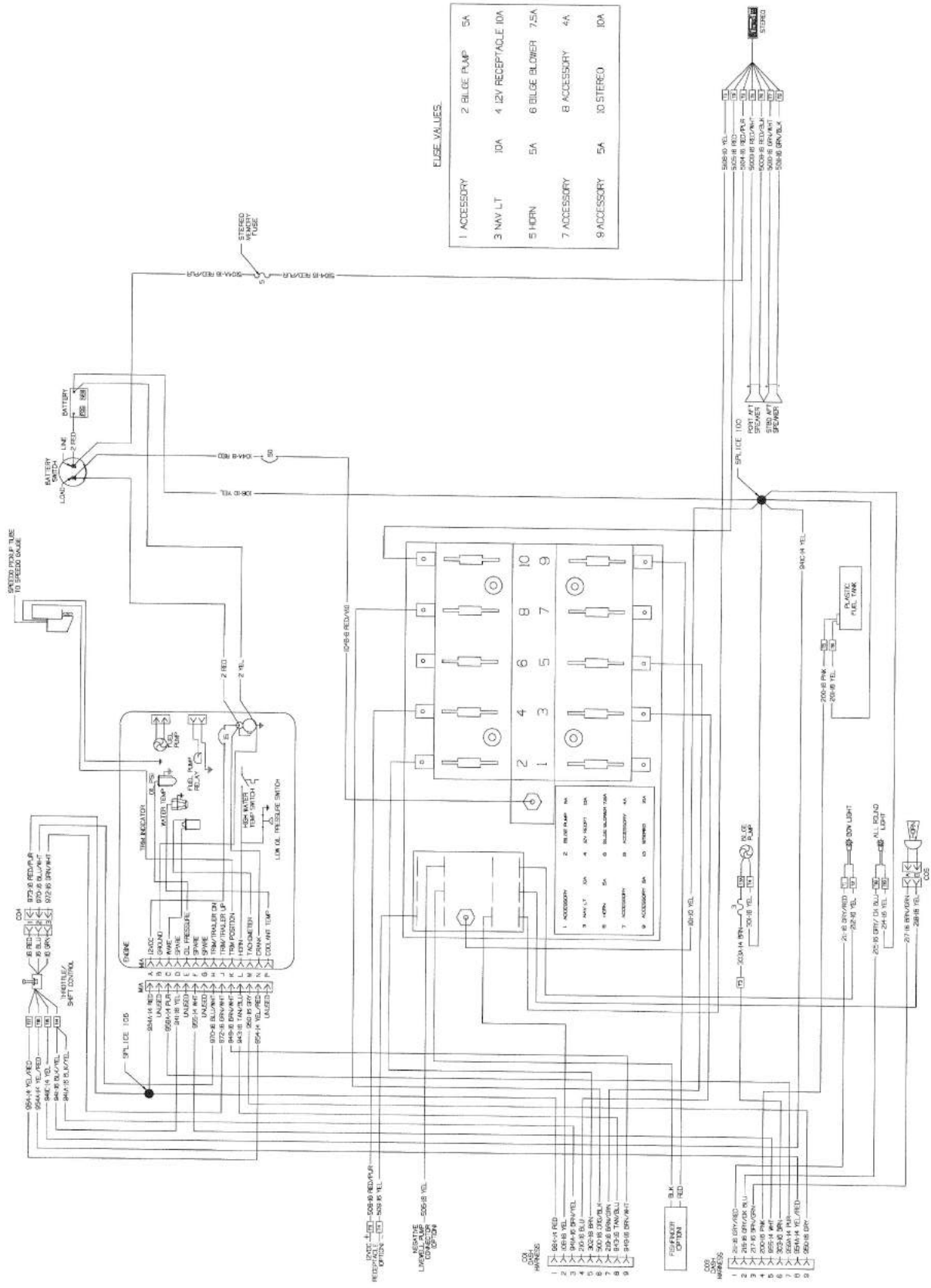

EDGE VALUES.

1	ACCESSORY	2	BILGE PUMP	5A
3	NAV. LT	4	12V RECEPTACLE	10A
5	HORN	6	BILGE BLOWER	7.5A
7	ACCESSORY	8	ACCESSORY	4A
9	ACCESSORY	10	STEREO	10A

Electrical Routings

12-Volt DC Deck Harnesses

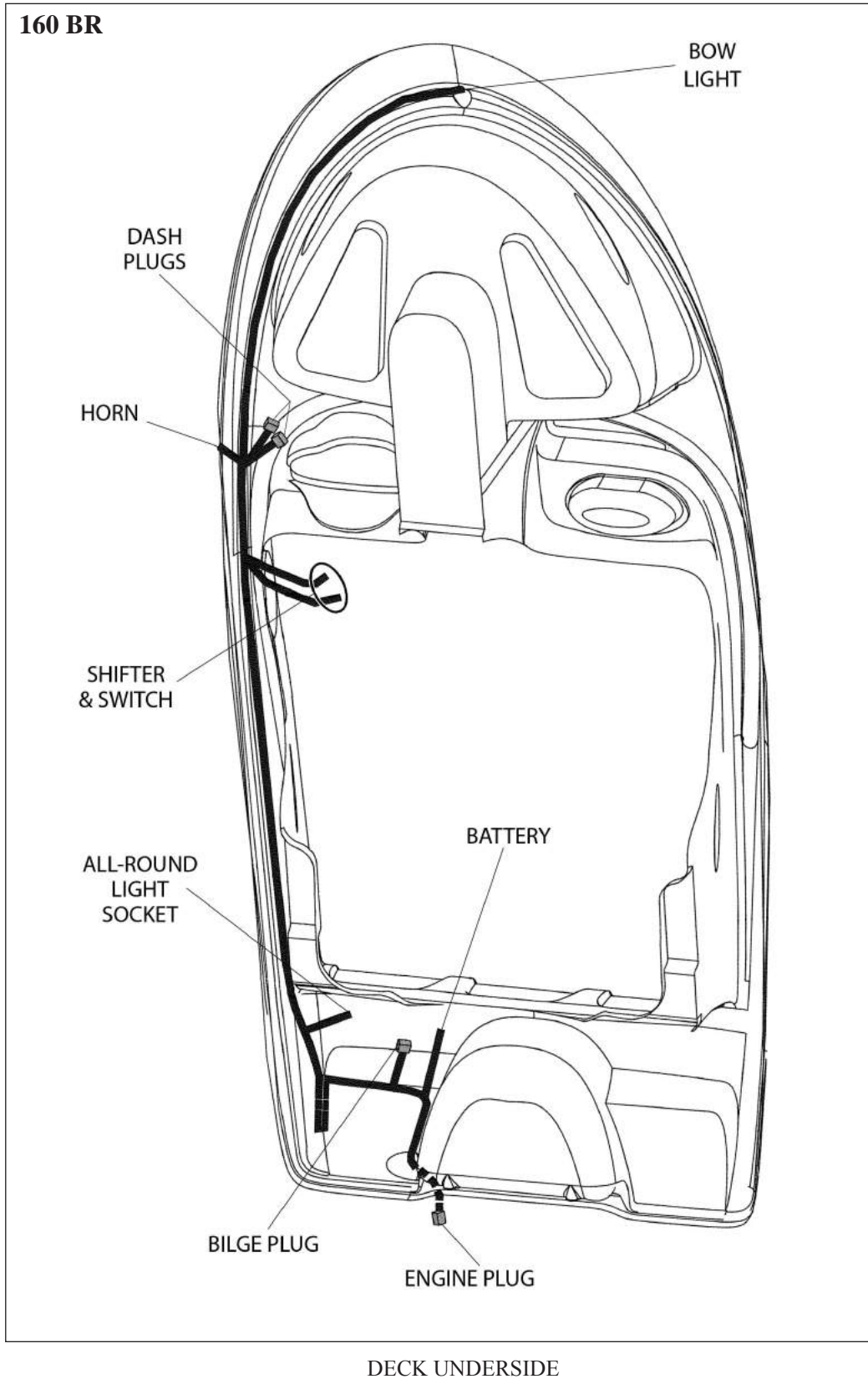

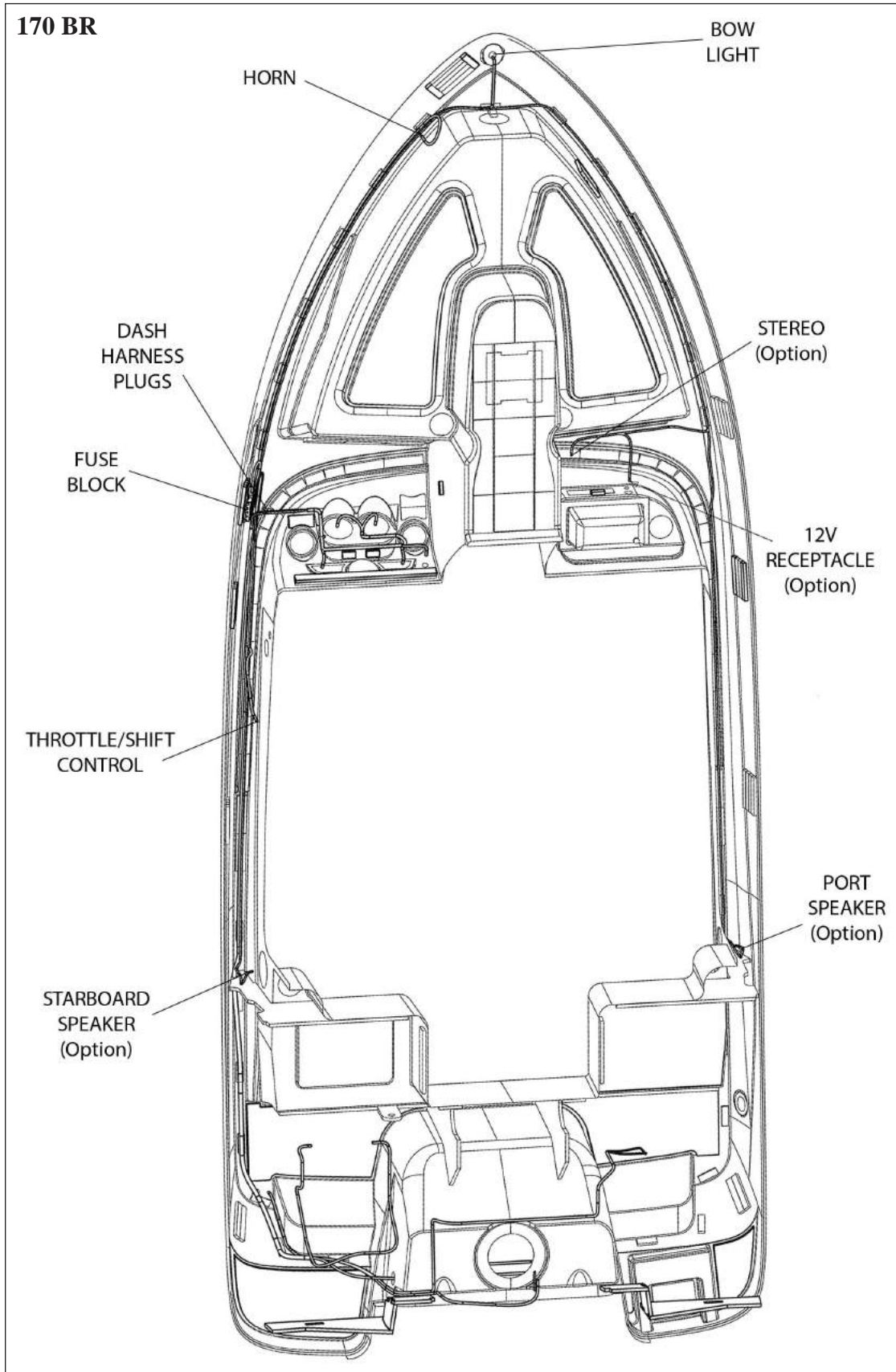

DECK UNDERSIDE

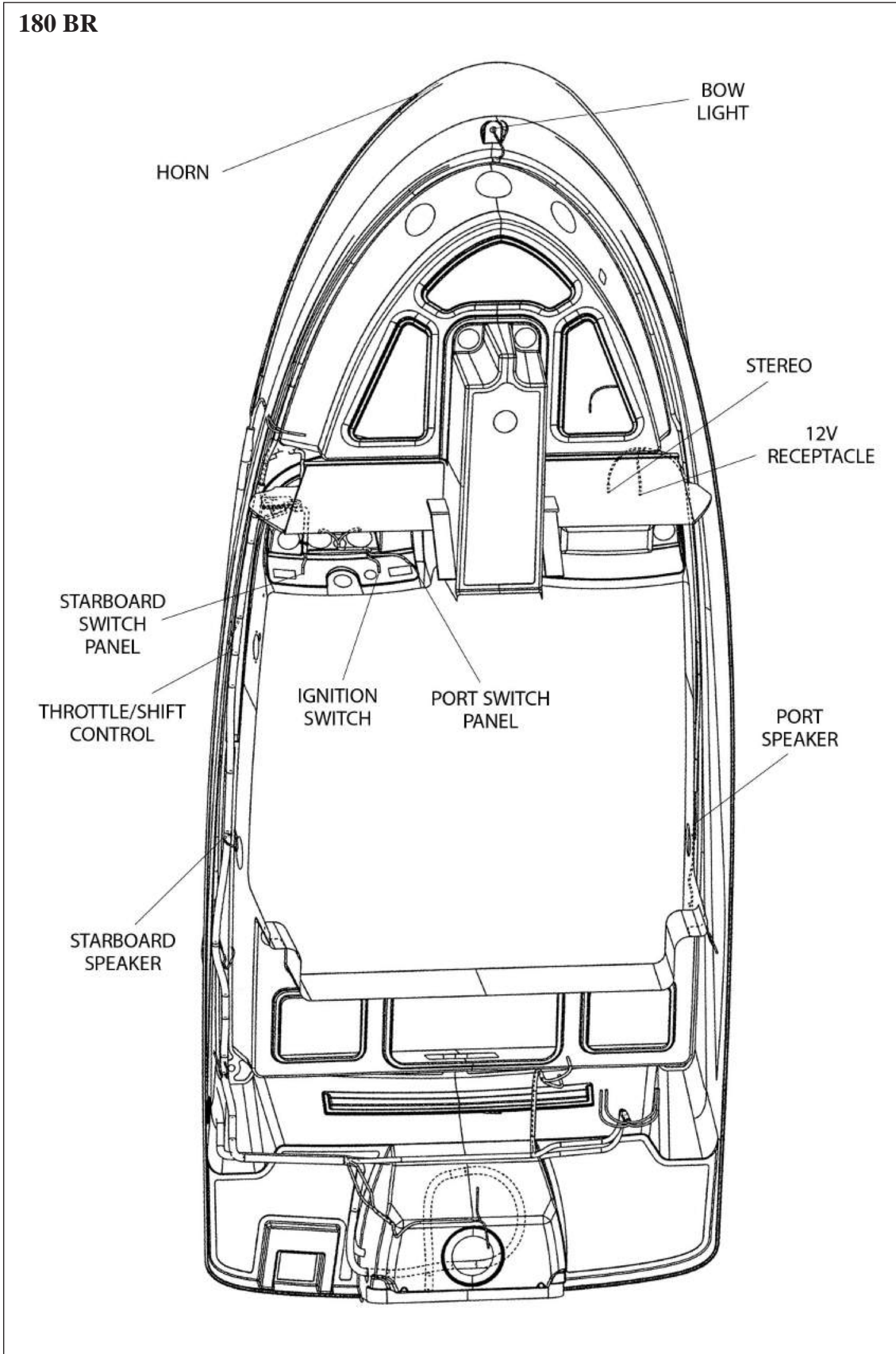

DECK UNDERSIDE

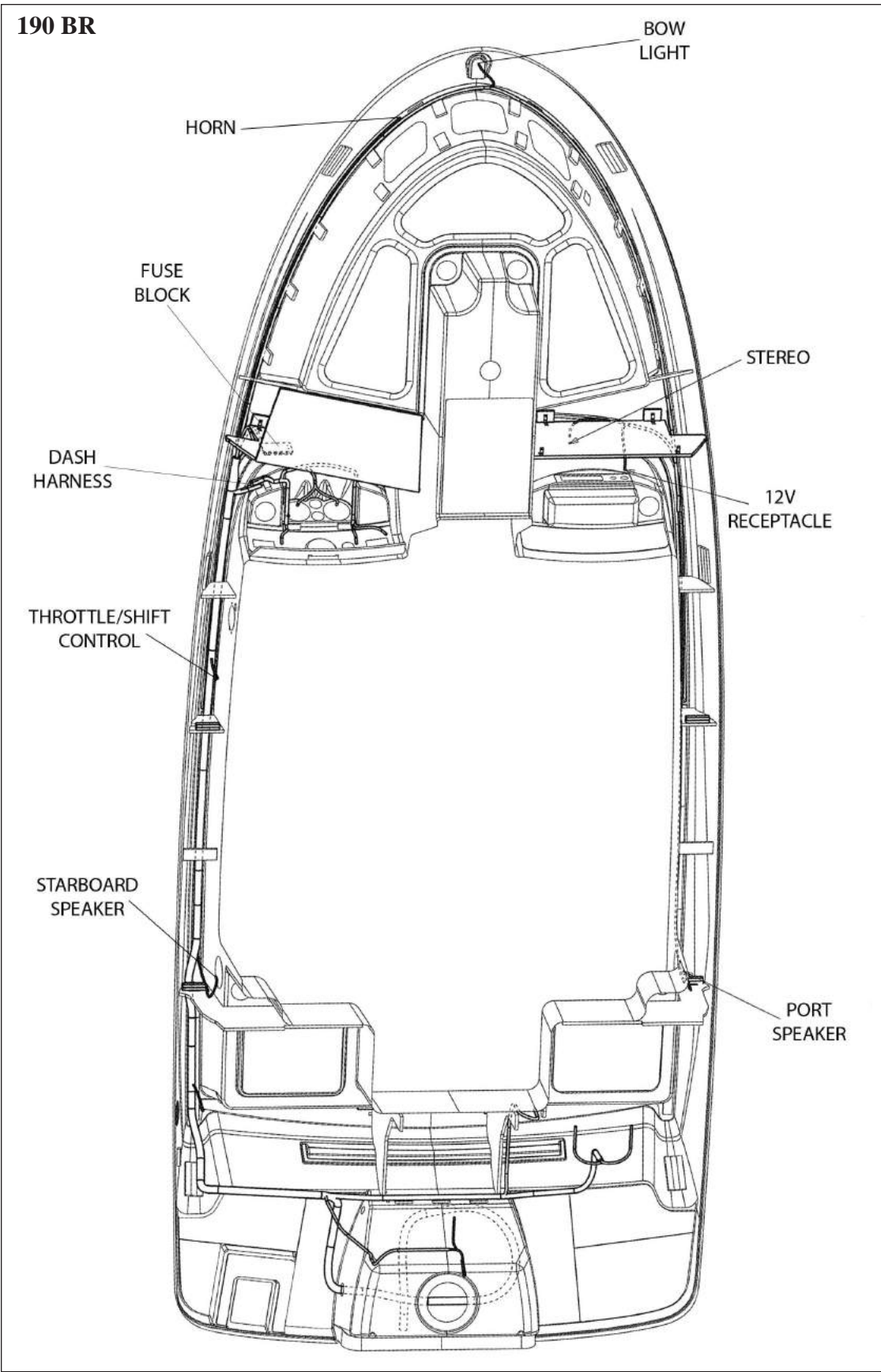

DECK UNDERSIDE

12-Volt DC Hull Harnesses

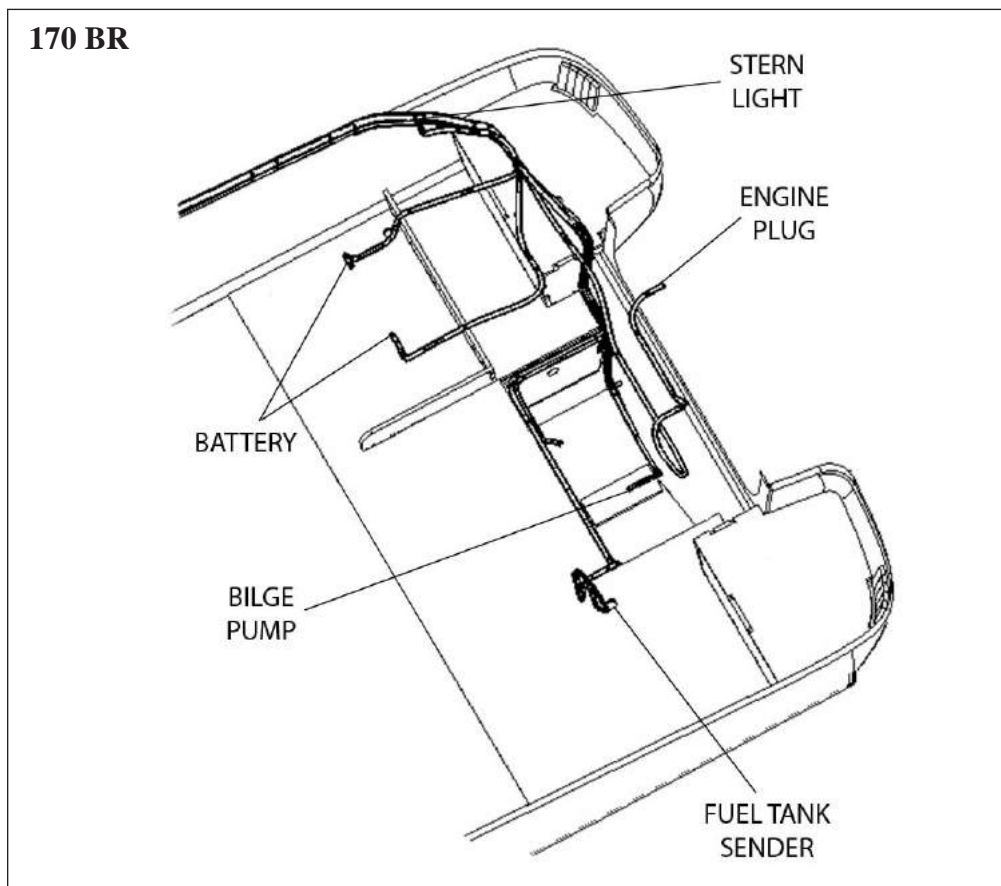
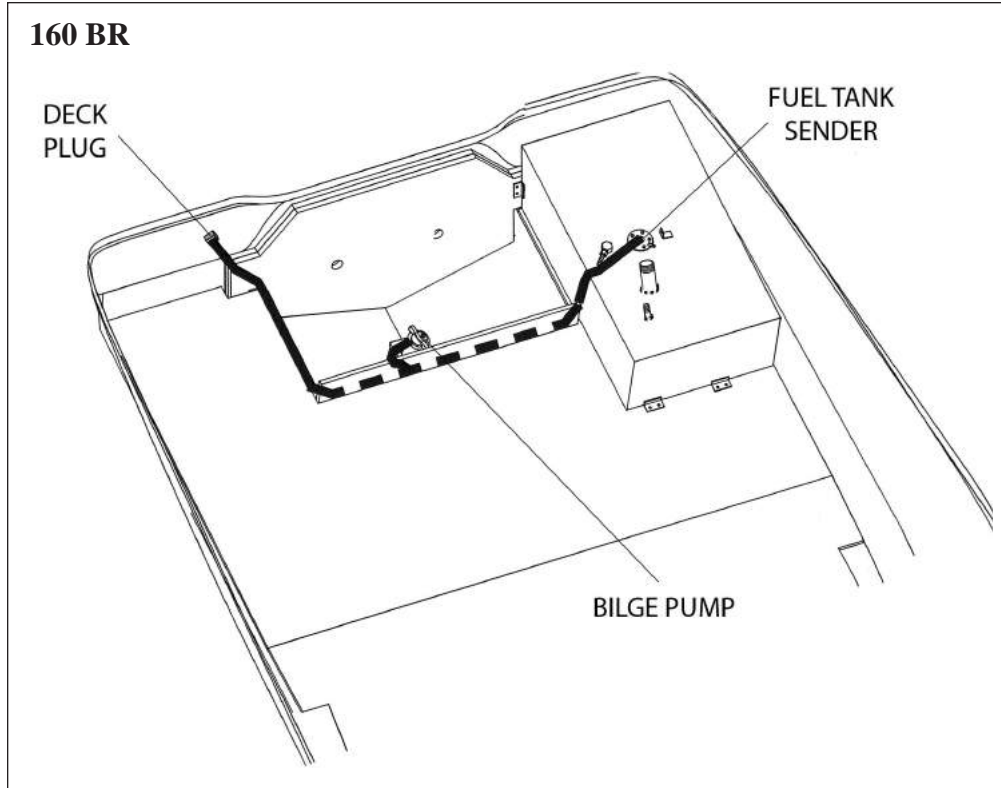

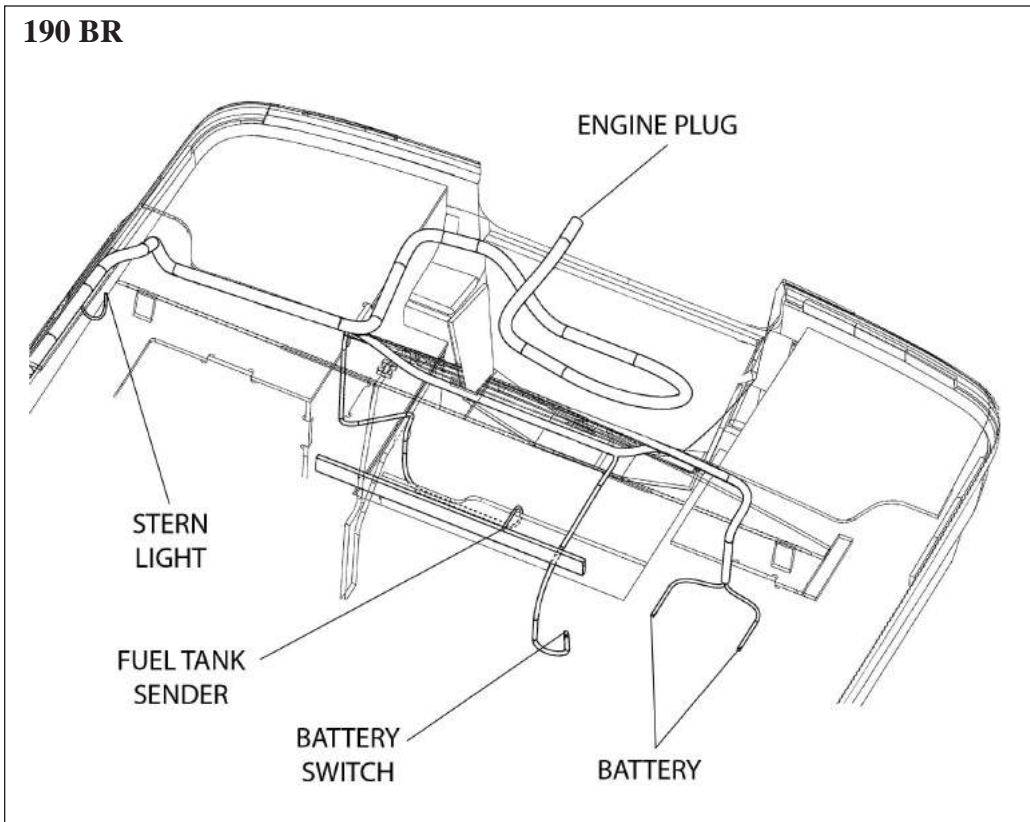
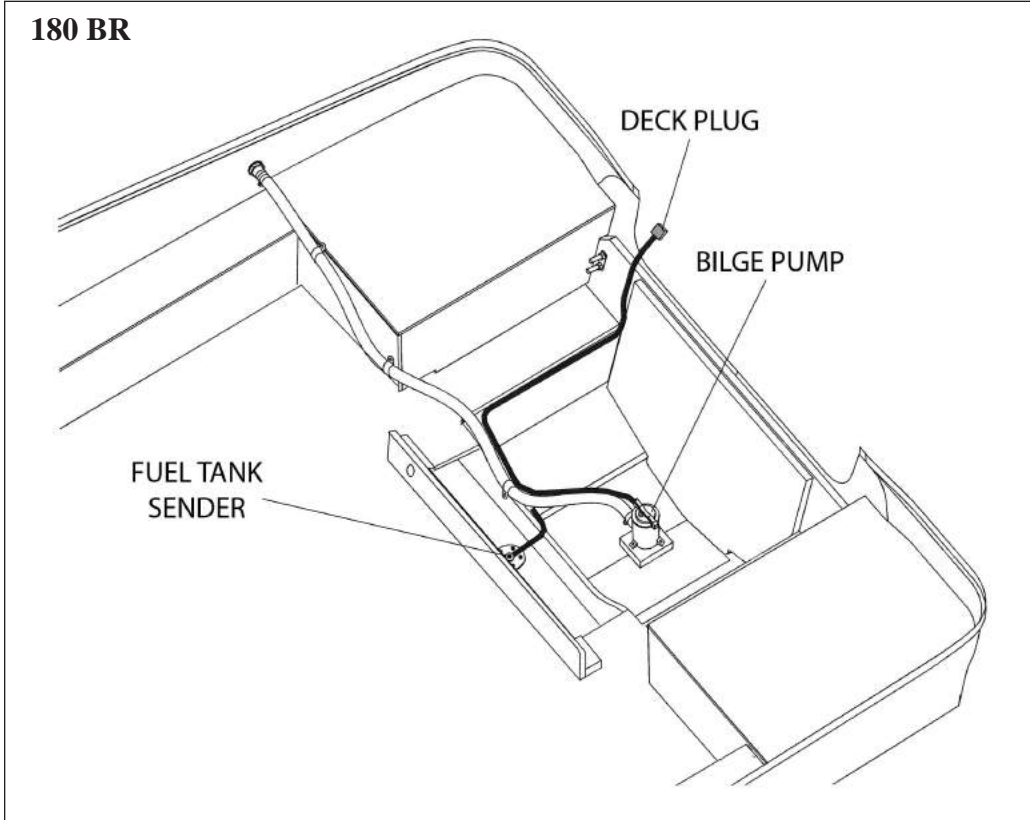

Battery Cable Routings

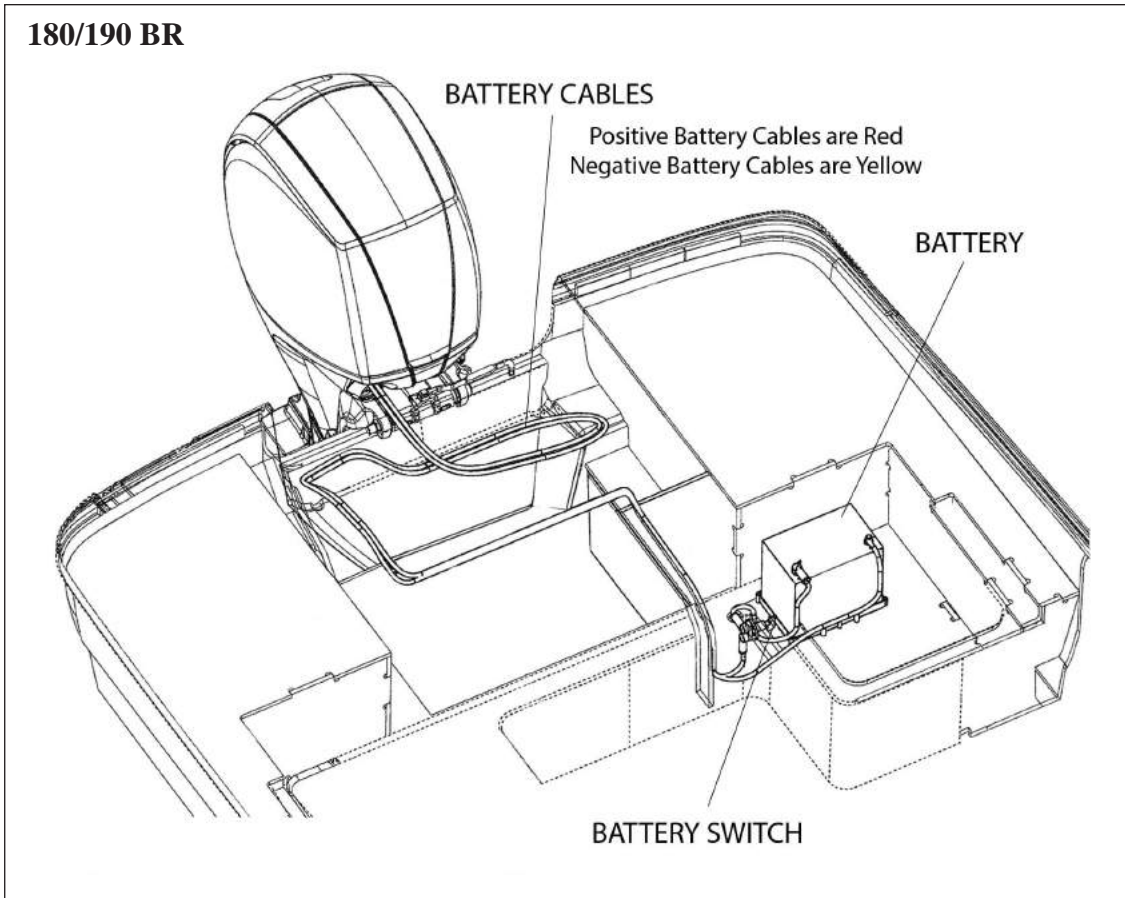
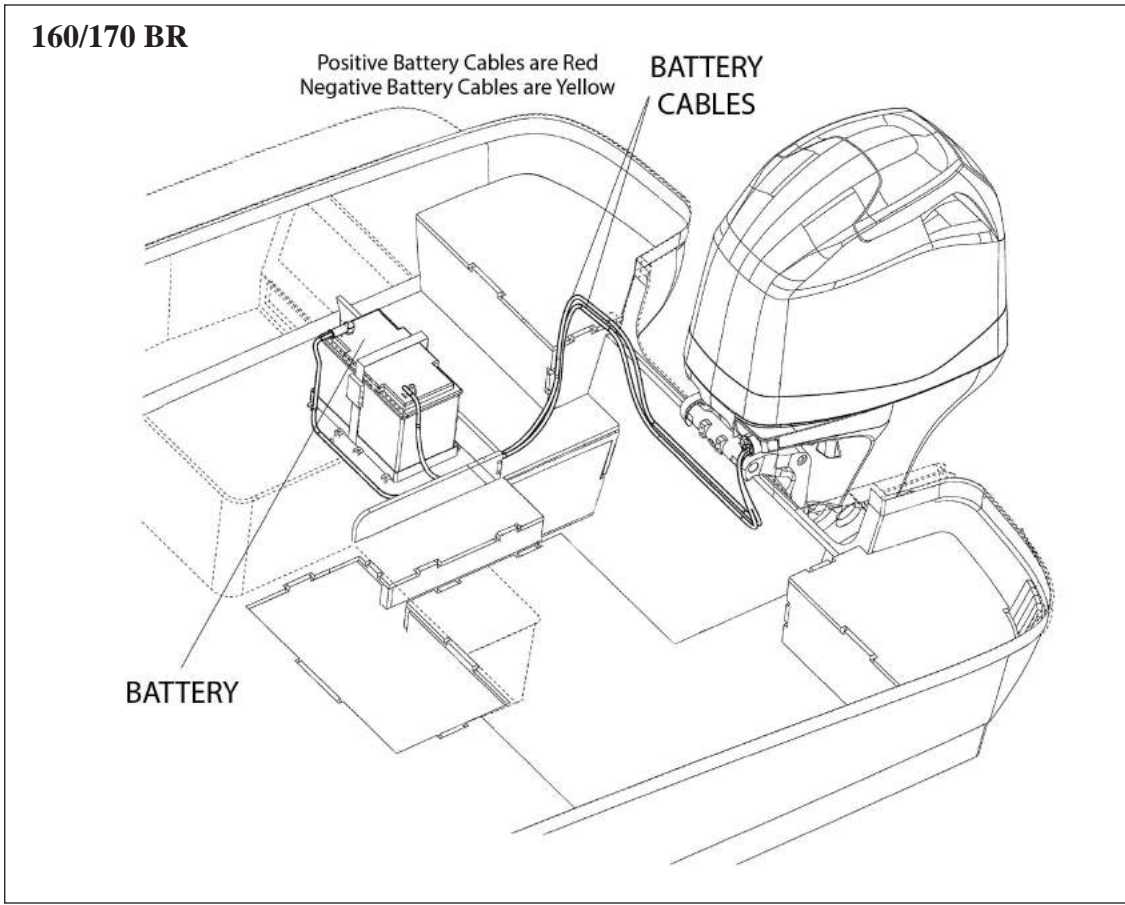

Important Records

Selling Dealer

Name Of Dealership

Address

Phone/FAX/E-mail

Sales Manager

Service Manager

Engine

Manufacturer

Model Name/Number

Engine Serial Number

Oil Type/SAE

Quarts per Engine

Filter Type

Propeller

Manufacturer

Pitch

Model Number

Key Numbers

Ignition

Other

Electronics

Manufacturer

Model Name/Number

Serial Number

Manufacturer

Model Name/Number

Serial Number

Manufacturer

Model Name/Number

Serial Number

Manufacturer

Model Name/Number

Serial Number

Manufacturer

Model Name/Number

Serial Number

